

Зип Общепит

vsezip.ru
+7(812)987-08-81
ESPLOSO RICAMBI
EXPLODED VIEWS

KORAL 980DB



KRUPPS
DISHWASHER MACHINES

Зип-защелка

vsezip.ru

+7(812)987-08181

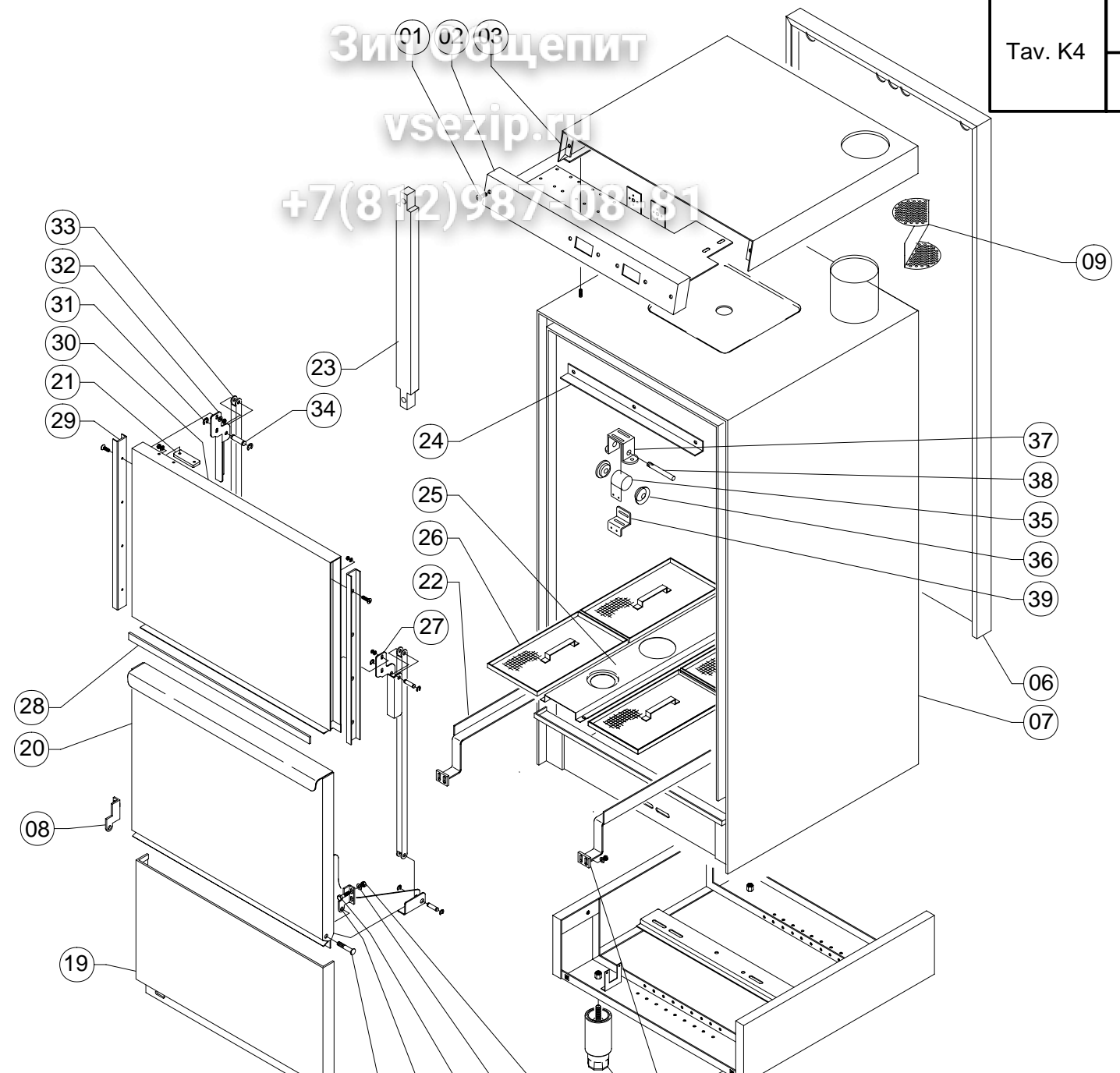

Zip OcцeпIT

					TAV. K4
POS.	CODICE MODELLO: 980DB - - -	DESCRIZIONE	DESCRIPTION	DESCRIPTION	BESCHREIBUNG
1	210	Vite TC croce inox M5x30	Stainless steel TC cross screw M5x30	Vis TC en croix inox M5x30	Kreuzschlitzschraube TC aus Edelstahl M5
2	950510	Pannello comandi	Command panel	Tableau des commandes	Bedienung mit Steuerungen
3	980500	Copertura inox	Stainless steel cover	Couverture inox	Abdeckung aus Edelstahl
6	980520	Schiera posteriore	Rear panel	Panneau arriere	Hinterere Ruckseite
7	980530	Vasca	Tank	Cuve	Becken
8	4001	Cerniera porta SX			
9	980548	Rondella Zn M6	Zn washer, M6	Rondelle ZN M6	Unterlegscheibe M6 aus ZN
10	950560	Zoccolo inox	Stainless steel base	Socle inox	Sockel aus Edelstahl
11	980570	Guida dx cesto quadro	Right-hand square basket guide	Guide droit panier carré	Rechte schiene quadratischer korb
12	1000090	Piedino regolabile	Adjustable foot	Pied réglable	Einstellbarer Fuß
13	110	Dado inox 5MA	Stainless steel nut, 5MA	Ecrou inox 5MA	Mutterschraube aus Edelstahl 5MA
14	160	Rondella inox M6	Stainless steel washer, M6	Rondelle inox M6	Unterlegscheibe aus Edelstahl M6
15	200	Vite TE inox M5x12	Stainless steel TE screw M5x12	Vis TE inox M5x12	Schraube TE aus Edelstahl M5x12
16	4000	Cerniera porta DX	Door hinge	Charnière porte	Scharnier Tür
17	4100	Perno inox porta	Stainless steel door pin	Goujon inox porte	Zapfen Tür aus Edelstahl
19	950550	Frontale inox inferiore	Lower stainless steel front panel	Bandeau frontal inox inférieur	Untere Front aus Edelstahl
20	980540	Porta inferiore	Lower door	Porte inférieur	Tür
21	1225	Magnete porta microinterruttore	Microswitch holding magnet	Aimant porte microcontact	Magnet Mikroschalter von Tür
22	980571	Guida sx cesto quadro	Left-hand square basket guide	Guide gauche panier carré	Linke Schiene quadratischer Korb
23	9801047	Guida teflon	Teflon Guide	Guide	Schiene
24	980548	Paraspruzzi	Upper panel	Panneau avant	Vordere abdeckung
25	9501020	Portafiltri centrale	Central filter holder	Porte filtres central	Zentrale Filterhalterung
26	9501011	Filtro piano vasca	Flat filter for tank	Filtre plat cuve	Filter Ablage becken
27	980546	Cerniera porta dx	Right-door hinge	Charnière droit porte	Rechte Scharnier Tür
28	980545	Guarnizione	Gasket	Joint	Dichtung
29	9801045	Guida Teflon	Teflon Guide	Guide	Schiene
30	980541	Porta	Door	Porte	Tür
31	100	Seeger	Seeger	Seeger	Seeger
32	980547	Cerniera porta sx	Left-door hinge	Charnière gauche porte	Linke Scharnier Tür
33	980541	Asta cerniera	Stainless steel guide	Guide inox	Edensthal schiene
34	4110	Perno lavaoggetti	Pin ware washer	Goujon lavebaterie	Zapfen
35	9803030	Molla ritorno porta	Spring	Ressort	Feder
36	9803031	Cuscinetto Dx/Sx	Right and left bearing	Douilles en PVC	PVC-Auflage
37	9803032	Supporto	Shaft	Support Ressort	Zapfenhalterung
38	9803033	Rullo inox	Stainless steel roller	Cylindre	Messinglauch
39	9803034	Staffa	Bracket	Entriere inferieur	Halterung

Зип ОбщеПИТ

vsezip.ru

+7(812)987-08-81

Tav. K16

KORAL 950DB-960DB-980D

GRUPPO POMPA / PUMP C

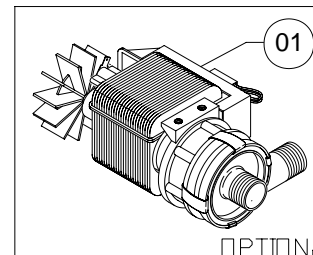
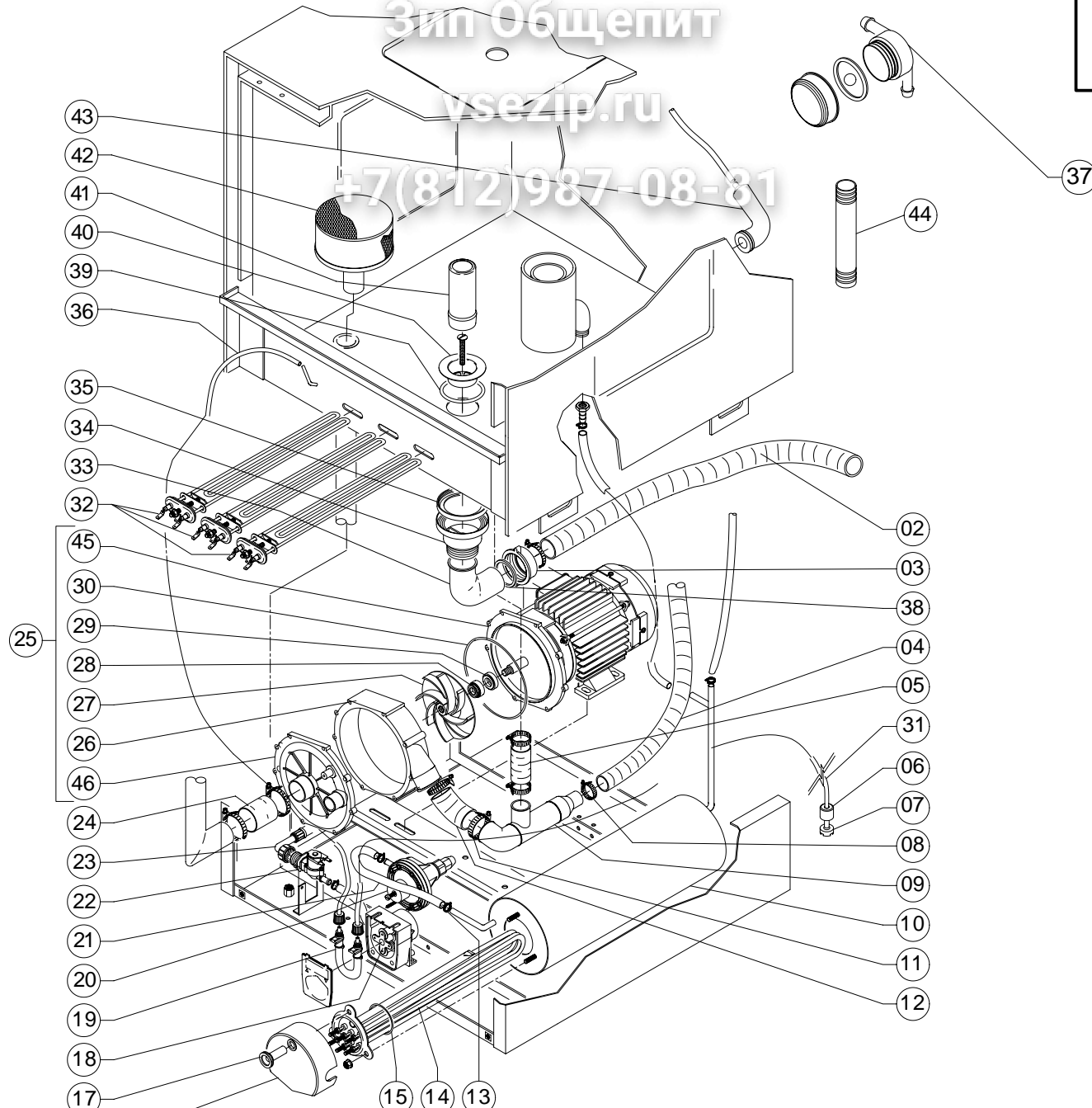

Zip Общепит

					TAV. K16			
POS.	KORAL				DESCRIZIONE	DESCRIPTION	DESCRIPTION	BESCHREIBUNG
	950	960	980	-				
1	5050	5050	5050		Optional mot. pompa scarico 190W	Optional discharge pump motor, 190W	Option moteur pompe vidange 190W	Opt. Motor für Pumpe vom Abfluß 190W
2	1320	1320	1320		Tubo di scarico ø32 mm	Discharge pipe, ø32 mm	Tuyau de vidange ø32 mm	Abflußschlauch ø32 mm
3	1367	1367	1367		Dado per codolo di scarico da 1"1/2G	Nut for discharge shaft, 1"1/2G	Ecrou pour extrémité tuyau de vidange de 1" 1/2G	Mutterschraube für Endstück vom Abfluß 1"1/2G Zoll
4	600720	600720	600720		Tubo ø30 lavaggio sup.	Upper wash pipe, ø30 mm	Tuyau ø30 lavage sup.	Lauch ø30 mm oberes Spülen
5	103543	103543	103543		Manicotto ø2 raccordo inf.	Lower joint coupling, ø32 mm	Manchon ø32 raccord inf.	Muffe ø32 mm unterer Anschluß
6	1215	1215	1215		Peso per tubetto aspirazione	Weight for intake tube	Poids pour petit tuyau aspiration	Gewicht für Ansaugschlauch
7	1218	1218	1218		Filtro per tubetto aspirazione	Filter for intake tube	Filtre pour petit tuyau aspiration	Filter für Ansaugschlauch
8	510	510	510		Fascietta inox 25-40	Stainless steel band, 25-40	Collier inox 25-40	Schelle aus Edelstahl 25-40
9	800750	800750	800750		Collettore inox lavaggio inferiore	Lower wash stainless steel manifold	Collecteur inox lavage inférieur	Sammler aus Edelstahl unteres Spülen
10	950420	950420	950420		Boiler inox	Stainless steel boiler	Chaudière-eau inox	Boiler aus Edelstahl
11	530	530	530		Fascietta inox 40-60	Stainless steel band, 40-60	Collier inox 40-60	Schelle aus Edelstahl 40-60
12	105060	105060	105060		Manicotto ø50 raccordo inf.	Coupling for lower joint, ø50 mm	Manchon ø50 raccord inf.	Muffe ø50 unterer Anschluß
13	500	500	500		Fascietta inox 10-16	Stainless steel band, 10-16	Collier inox 10-16	Schelle aus Edelstahl 10-16
14	103432	103432	103432		Resistenza boiler 6000 W	Boiler heater, 6000W	Résistance chauffe-eau 6000W	Heizschlange Boiler 6000W
15	103435	103435	103435		Guarnizione or per resist. 4500W	OR heater gasket 4500W	Bague torique résistance 4500W	O-Ring-Dichtung für Heizsch. 4500W
16	103460	103460	103460		Protezione resistenza boiler	Boiler heater protection	Protection résistance chauffe-eau	Schutz für Heizschlange Boiler
17	103470	103470	103470		Nottolino coperchio resistenza	Heater cover pawl	Cliquet couvercle résistance	Sperrzahn für Deckel von Heizschlange
18	1220K	1220K	1220K		Dosatore detergente elettrico regolab.	Adjustable electric detergent doser	Doseur détergent électrique réglable	Elektr., einstellbarer Dos. für Spülmittel
19	1212	1212	1212		Tubetto in santoprene	Santoprene tube	Petit tuyau en santoprène	Kleiner Schlauch aus Santopren
20	1200	1200	1200		Dosatore di brillantante	Rinse doser	Doseur de liquide rinçage	Dosierer für Klarspüler
21	1380	1380	1380		Tubo gomma 10-19 90°C al mt	Rubber hose, 10-19 90°C per metre	Tuyau en caoutch. 10-19 90°C au mètre	Gummischlauch 10-19 90°C, pro lfd. M
22	103370	103370	103370		Elettrovalvola	Solenoid valve	Electrovanne	Elektroventil
23	1305	1305	1305		Tubo carico acqua da 2.0 mt	Water entry pipe, 2.0 m	Tuyau de remplissage eau de 2 m	Wasseransaugschlauch, 2 m lang
24	106070	106070	106070		Manicotto ingresso pompa	Pump entry rubber hose	Manchon entrée pompe	Muffe Pumpeneingang
25	6900	6900	6900		Motore pompa lavaggio HP 3	Wash pump motor, 3 HP	Moteur pompe lavage HP 3	Motor Spülpumpe 3 PS
26	6810	6810	6810		Chiocciola mandata motore pompa	Pump motor volute	Vis sans fin moteur pompe	Spiralgehäuse Pumpenmotor
27	6811	6811	6811		Girante pompa	Pump rotor	Roue pompe	Lauftrad Pumpe
28	6014	6014	6014		Guarnizione tenuta rotante	Rotary sealing gasket	Joint d'étanchéité rotatif	Dichtung Lauftrad
29	6013	6013	6013		Guarnizione tenuta ceramica	Ceramic sealing gasket	Joint d'étanchéité céramique	Keramikdichtung
30	6812	6812	6812		Guarnizione or per chiocciola pompa	Pump volute OR gasket	Bague torique pour vis sans fin pompe	O-Ring-Dichtung für Spiralgeh. Pumpe
31	1420	1420	1420		Tubetto 6x4 azzurro per DB			
32	103408	103408	103408		Resistenza vasca 2000 W	Tank heater, 2000W	Résistance cuve 2000 W	Heizschlange Becken 2000 W
33	1365	1365	1365		Codolo curvo scarico da 40 mm	Curved discharge shaft, 40 mm	Extrémité coude vidange de 40mm	Gebogenes Endstück . Abfluß 40 mm
34	1362	1362	1362		Raccordo polietilene	Joint	Raccord	Anschluß
35	1363	1363	1363		Guarnizione esterna piana	Gasket for discharge drain	Joint pour siphon vidange	Dichtung für Ablauf vom Abfluß
36	1421	1421	1421		Tubetto 6x4 giallo per DD	Transparent tube, 6x4 mm	Petit tuyau 6x4 mm transparent	Kleiner transparen. Schlauch 6x4 mm
37	1500	1500	1500		Valvola antiriflusso			
38	1366	1366	1366		Guarnizione codolo	Gasket	Joint	Dichtung
39	1361	1361	1361		Guarnizione or interna per piletta inox	OR gasket	Bague torique	O-Ring-Dichtung
40	1360	1360	1360		Piletta inox da 1"1/2	Inox drain, 1"1/2	Siphon inox de 1"1/2	Inoxblauf 1"1/2 Zoll
41	1201091	1201091	1201091		Tubo troppo pieno inox ø40	Stainless steel "too full" pipe ø40	Tuyau trop-plein inox ø40	Überlaufrohr aus Edelstahl ø40
42	3260	3260	3260		Filtro inox	Stainless steel filter	Filtre inox	Filter aus Edelstahl
43	3280	3280	3280		Trappola d'aria	Air trap	Prise d'air	Luftfalle
44	630	630	630		Collettore inox lavaggio superiore	Upper wash stainless steel manifold	Collecteur	Sammler aus Edelstahl
45	6813	6813	6813		Flangia motore pompa HP 3.0	Flange wash pump 3.0 HP	Bride moteur pompe	Flansch Pumpenmotor

Зип Общепит

vsezip.ru

+7(812)987-08-81

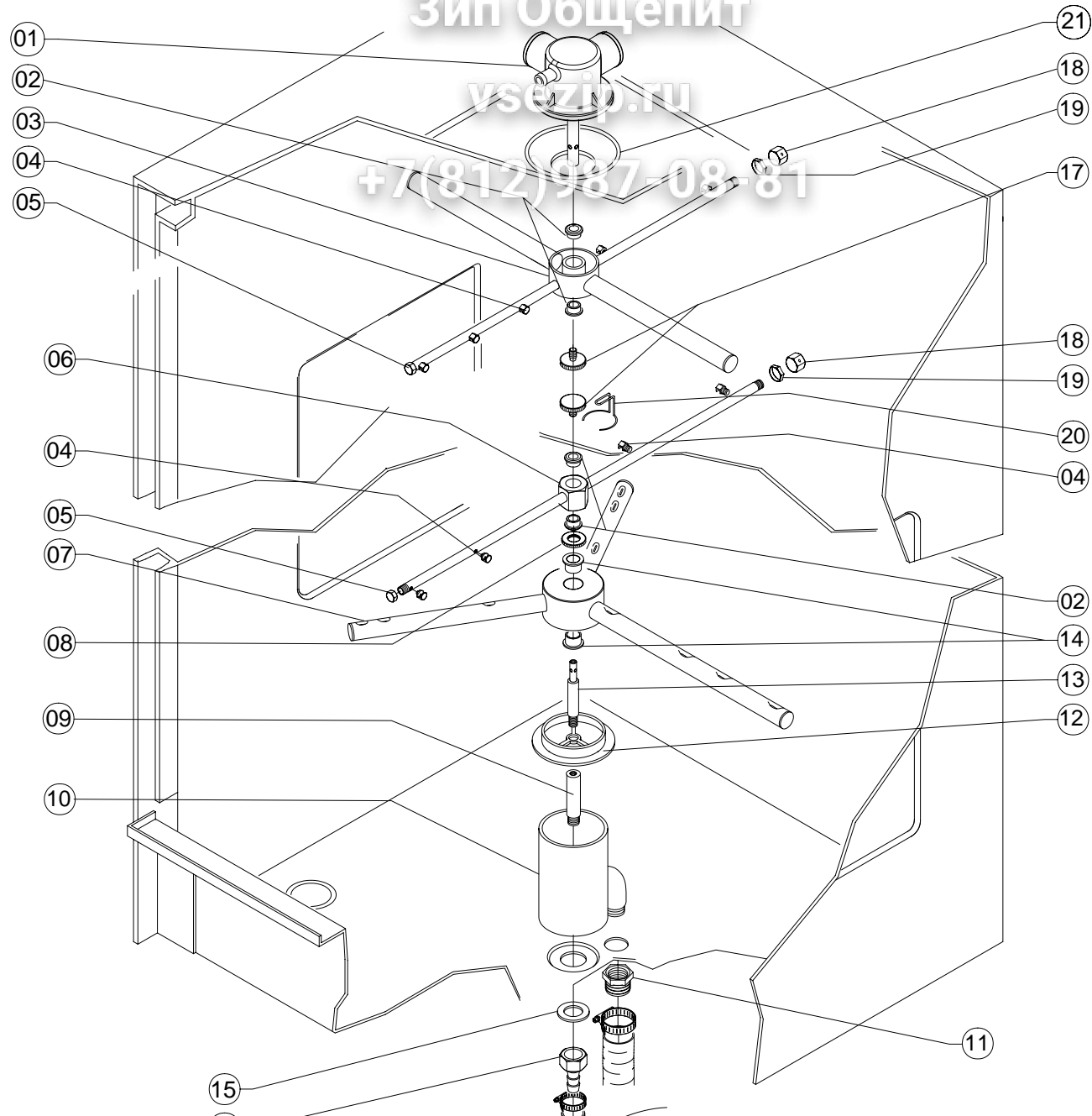

Тав. K27	KORAL 950DB - 960DB - 980
	GIRANTE / WASH ARMS

Зип Общепит

vsezip.ru

+7(812)987-08-81

Тав. K38	KORAL 950DB - 960DB - 980DB
	IMPIANTO ELETTRICO ELECTRICAL CIRCUIT

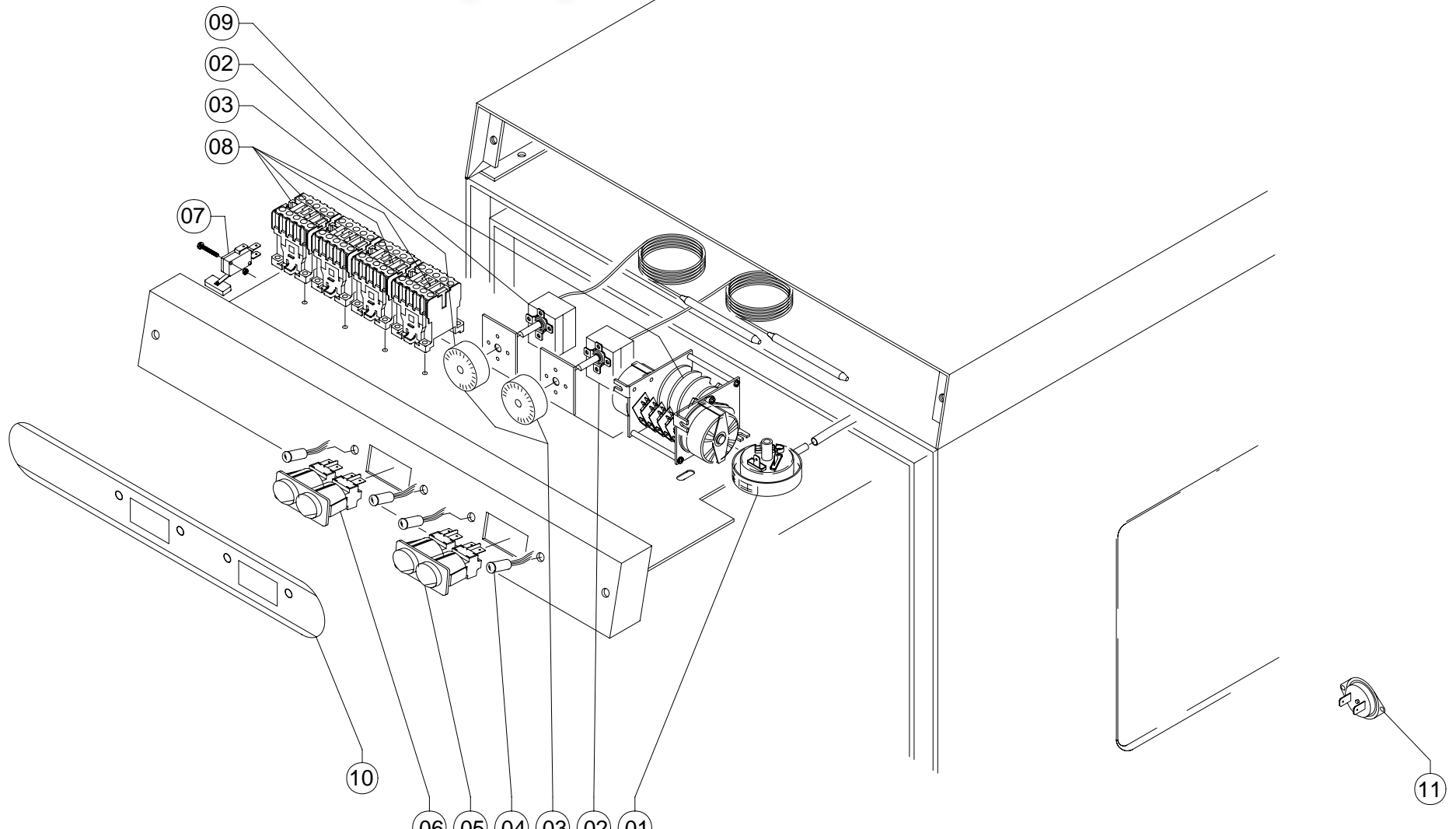

Зип Ощепит

vsezip.ru

+7(812)987-08-81

Tav. K48

KORAL 950DB-960DB-980DB-

CESTELLI / BASKETS

