

3ип Общепит
vsezip.ru
+7(812)987-08-81

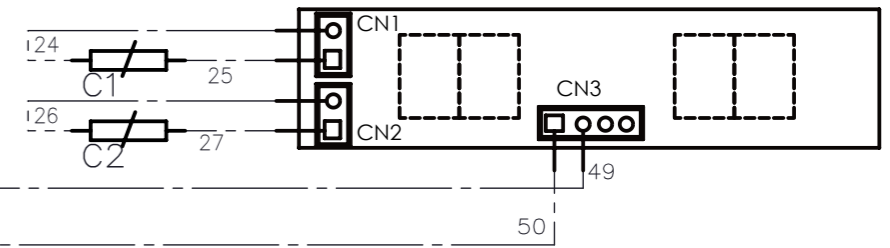
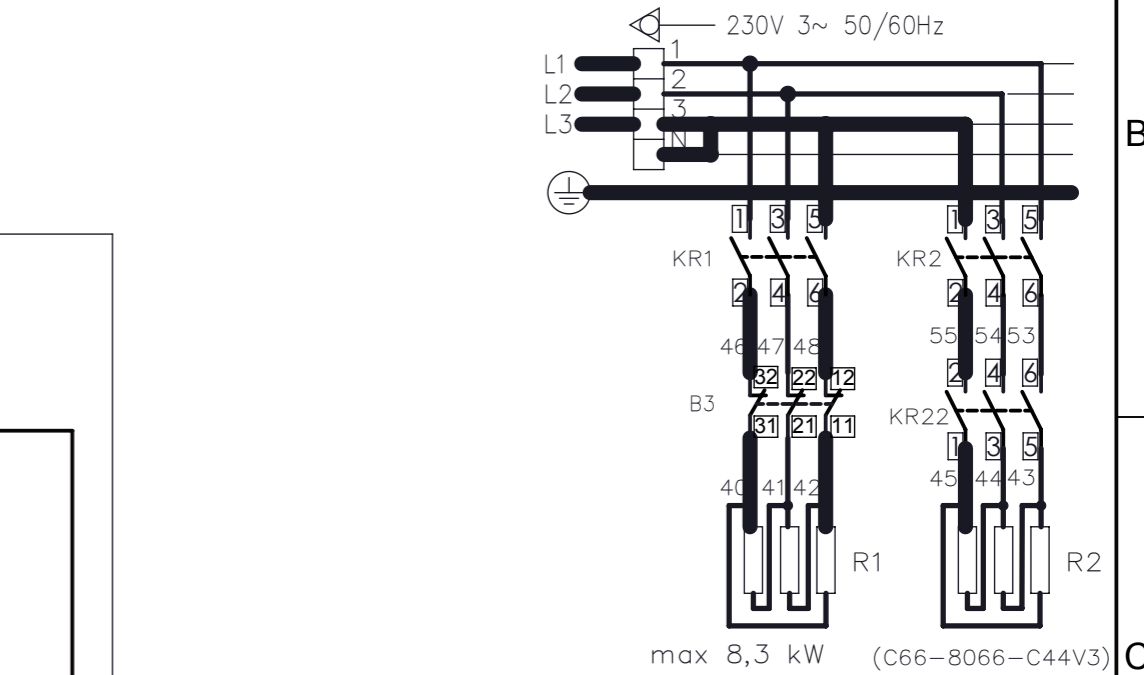
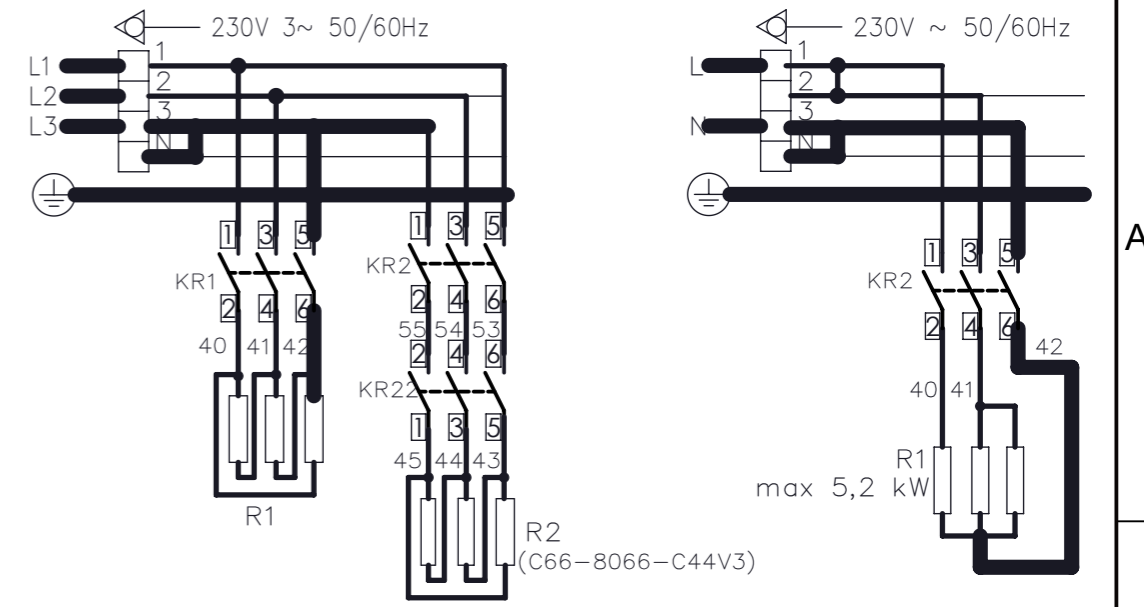

T3 (D85-F99-D120-F912)
(C44-8044-C66-8066)

- 4 mm²
- 2,5 mm²
- 1,0 mm²
- 0,35 mm²

Il presente documento costituisce materiale riservato di rilevante valore economico per il costruttore. Può essere utilizzato solo per soddisfare ordini di fornitura a favore del costruttore e non può essere comunicato, trasferito o consegnato, in tutto o in parte, a terzi.

Denominazione		SCHEMA ELETTRICO C34/44/66+D85/120 DGT	
Modello		C34+C44+C66+D85+D120 DGT	
Data	Formato	Dis. nr.	Ediz.
04/10/2016	A3	C+D_digit_001	1.00
Disegnato da		S.Tribbia	

Зип Общепит

vsezip.ru

+7(812)987-08-81

	I	GB	F	D	E	P
0-I	Interruttore principale (a carico del cliente)	Main switch (charged to the customer)	Interrupteur principal (à la charge du client)	Hauptschalter (zu Kosten des Kunden)	Interruptor principal (a cargo do cliente)	Interruptor principal (por conta do cliente)
B1	Termostato boiler	Boiler thermostat	Thermostat surchauffeur	Thermostat Boiler	Termostato de la caldera	Termóstato de caldeira
B2	Termostato vasca	Tank thermostat	Thermostat cuve	Thermostat Tank	Termostato de la cuba	Termóstato da cuba
B3	Termostato sicurezza boiler	Boiler safety thermostat	Thermostat sécurité surchauffeur	Sicherheitsthermostat Boiler	Termostato de seguridad de la caldera	Termóstato de segurança da caldeira
B4	Protezione termica salvamotore	Motor thermal protection	Protection thermique moteur	Motor-Wärmeschutzschalter	Protección termica del motor	Proteção termica do motor
C1	Sonda temperatura vasca	Tank temperature probe	Sonde de température de la cuve	Temperatursonde Tank	Captador temperatura caldera	Sonda temperatura tanque
C2	Sonda temperatura boiler	Boiler temperature probe	Sonde de température du surchauffeur	Temperatursonde Boiler	Captador temperatura cuba	Sonda temperatura boiler
F1	Micro porta	Door microswitch	Micro contact de porte	Mikroschalter Tür	Microrruptor de la puerta	Microinterruptor da porta
H1	Spia pronto macchina	Machine ready lamp	Voyant fonctionnement	Kontrolleuchte Betriebsbereitschaft	Piloto "máquina lista"	Piloto "máquina pronta"
K1	Relè di linea	Main relay	Relais marche/arrêt	Relais Ein/Aus	Relé suministro de corriente	Relé de alimentação elétrica
KM1	Teleruttore lavaggio	Wash pumps contactor	Contacteur electropompe lavage	Schütz Spülzone	Telerruptor variador de velocidad	Contactor variador de velocidade
KM5	Teleruttore pompa risciacquo	Rinse booster pump contactor	Contacteur moteur pompe auxiliaire	Schütz Motor Drucksteigerungspumpe	Telerruptor motor bomba para aumentar la presión	Contactor motor bomba de enxágue
KR1	Teleruttore resistenza boiler	Boiler heating element contactor	Contacteur résistance surchauffeur	Schütz Boilerheizelement	Telerruptor resistencia de la caldera	Contactor resistencia cilindro
KR2 KR22	Teleruttore resistenza vasca	Tank heating element contactor	Contacteur résistance de cuve	Schütz Tankheizelement	Telerruptor resistencia cuba	Contactor resistências cuba
M1	Elettropompa lavaggio	Wash pump	Electropompe lavage	Elektropumpe Spülzone	Electrobomba lavado	Electro-bomba lavagem
M4	Dosatore detersivo	Detergent dispenser	Pompe produit lavage	Dosiergerät Spülmittel	Dosificador detergente	Doseador para detergente
M5	Motore pompa risciacquo	Rinse booster pump motor	Moteur pompe auxiliaire	Motor Drucksteigerungspumpe	Motor bomba para aumentar la presión	Motor da bomba de enxágue
M6	Motore pompa scarico	Drain pump motor	Moteur pompe vidange	Motor Laugenpumpe	Motor bomba de desagüa	Motor da bomba de esgoto
M7	Dosatore brillantante	Rinse agent dispenser	Doseur produit rinçage	Dosiergerät Klarspülmittel	Dosificador líquido tensioactivo	Doseador do produto de enxágue
P1	Pressostato livello vasca lavaggio	Wash tank level pressure switch	Pressostat niveau cuve lavage	Pressostat Waschwanne	Presostato nivel cuba lavado	Pressóstato nivel cuba lavagem
R1	Resistenza boiler	Boiler heating element	Résistance du surchauffeur	Heizelement Boiler	Resistencia calentadora de la caldera	Resistência da caldeira
R2	Resistenza vasca	Tank heating element	Résistance de cuve	Heizelement Tank	Resistencia calentadora de la cuba	Resistência da cuba
T1	Scheda controllo ciclo	Electronic control	Carte contrôle cycle	Elektronikmodul Programmschaltwerk	Electrónica de controló ciclo	Módulo electrónico temporizador de ciclo
T2	Scheda tastiera	Push botton plate	Fiche poissoir	Elektronikmodul Testatur	tarjeta pulsador	placa botões
T3	Scheda termometri	Thermometer plate	Fiche thermometre	Elektronikmodul thermometer	tarjeta termò	placa termómetro
U1	Morsettiera	Terminal board	Domino de ligne	Klemmenleiste	Regleta de connexion	Placa de terminais
Y1	Elettrovalvola carico/risciacquo caldo	Fill/hot rinse/Cold solenoid valve	Electrovanne remplissage/rinçage chaud	Magnetventil Fullung/Nachspülung warm	Electroválvula de llenado/ aclarado en caliente	Electroválvula de enchimento/ enxaguamento a quente

Зип Общепит

vsezip.ru

C34 dgt
+7(812)987-08-81

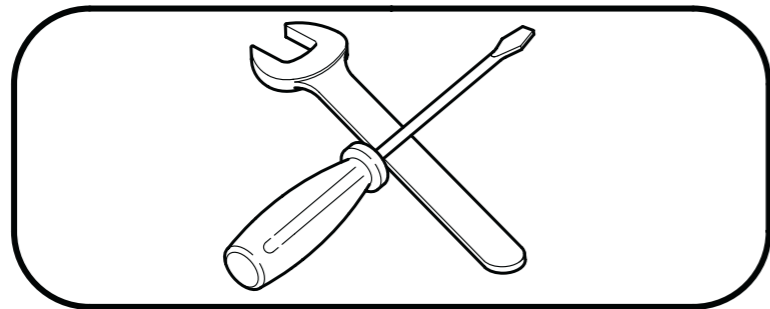
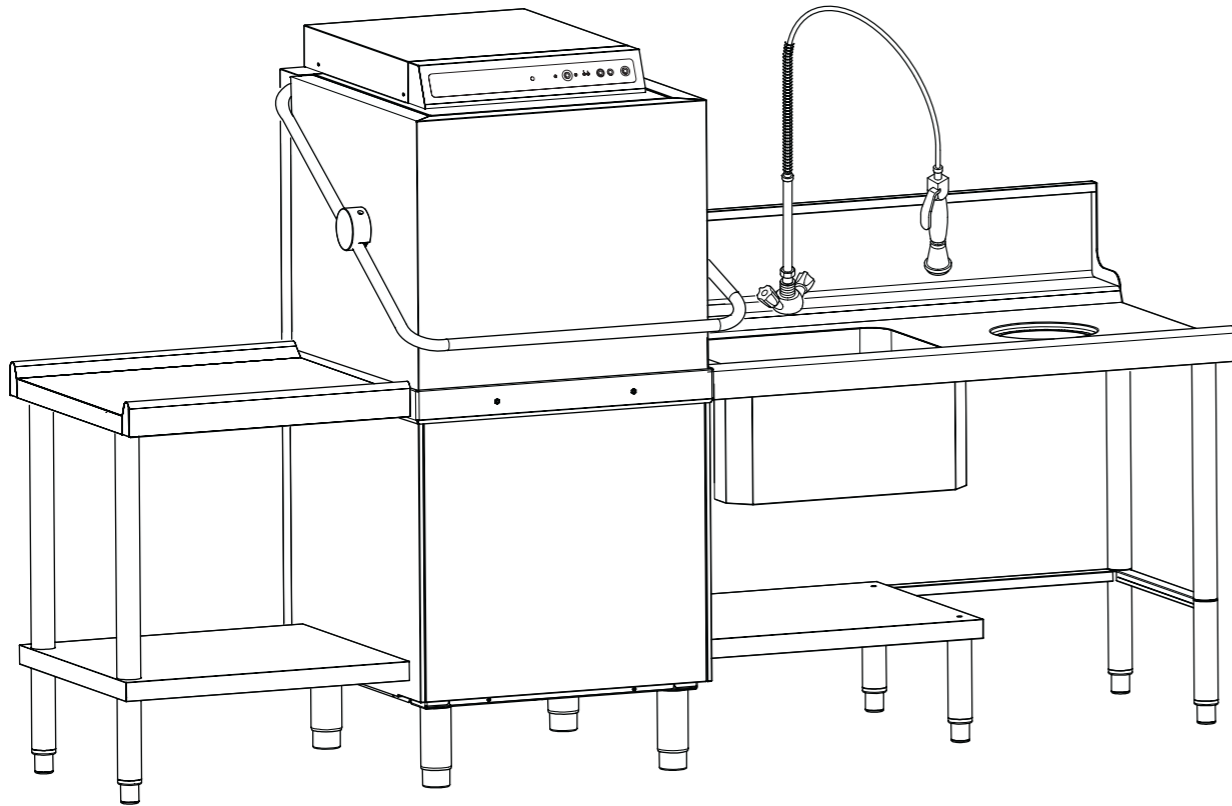

TAV.1

Зип Общепит

vsezip.ru

+7(812)987-08-81

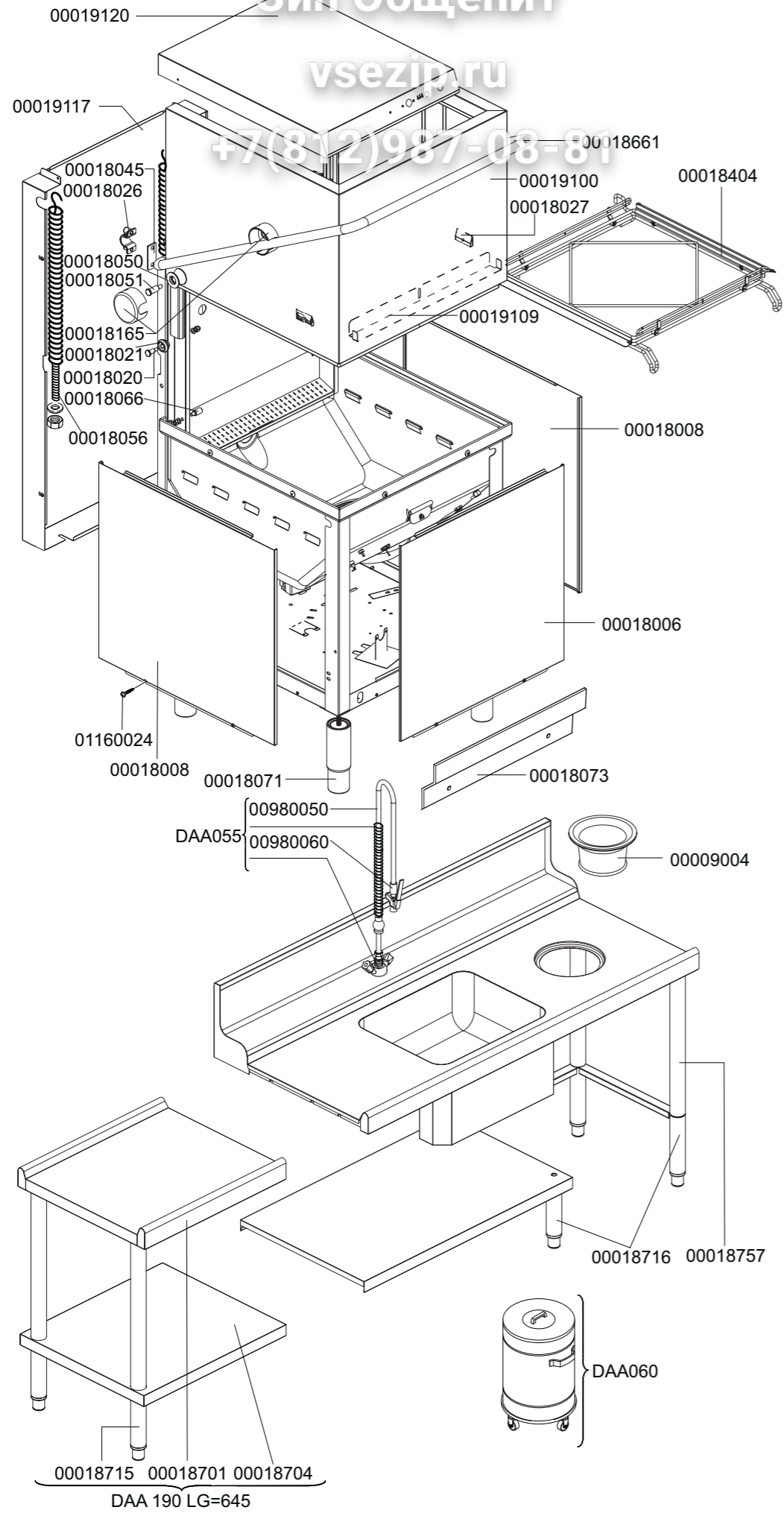

TAV 2
Зип-Общепит

vsezip.ru

8(812)987-08-81

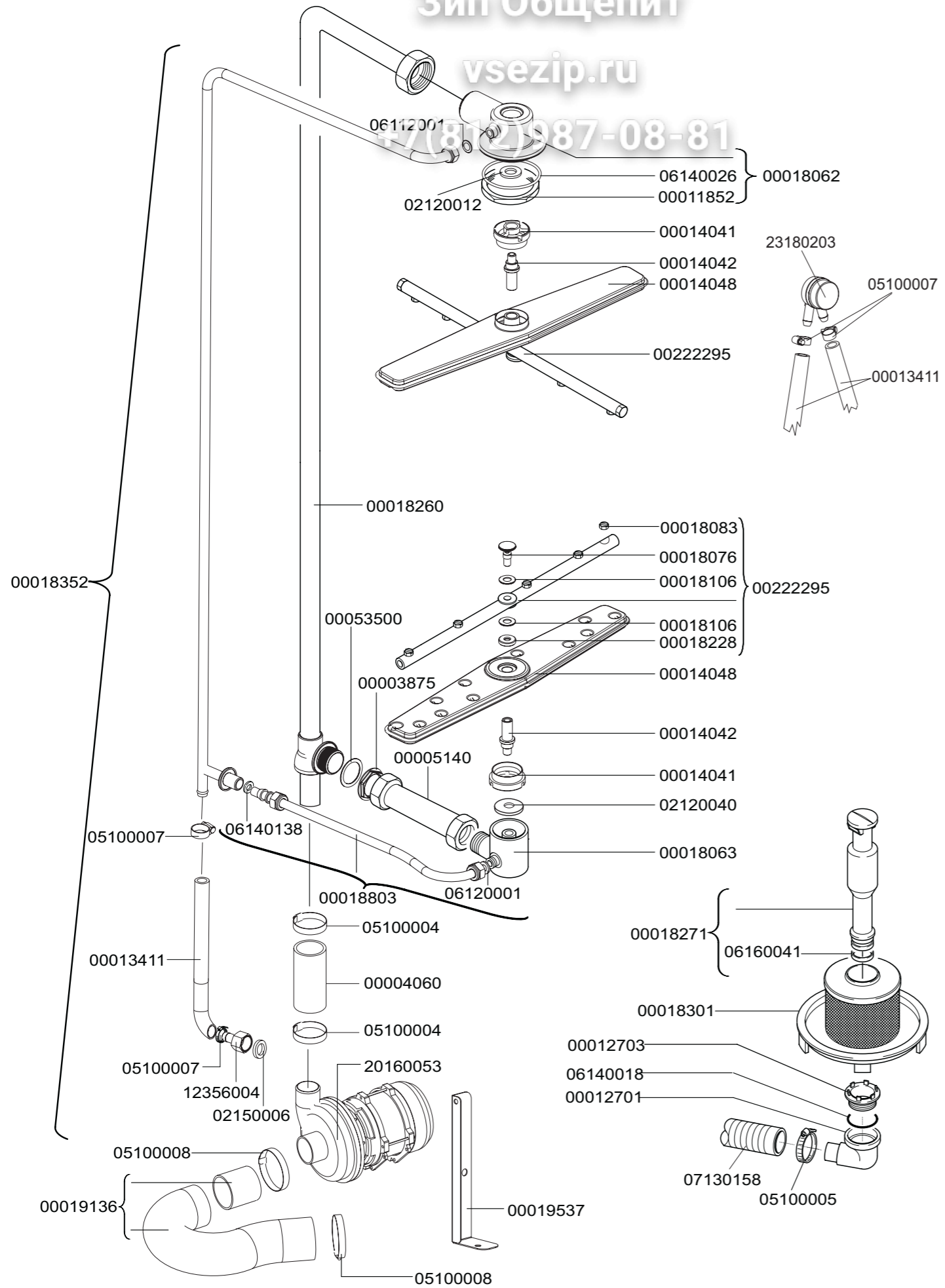

TAV.3
Зип Общепит

vsezip.ru

+7(812)987-03-81

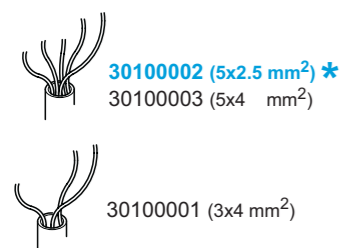
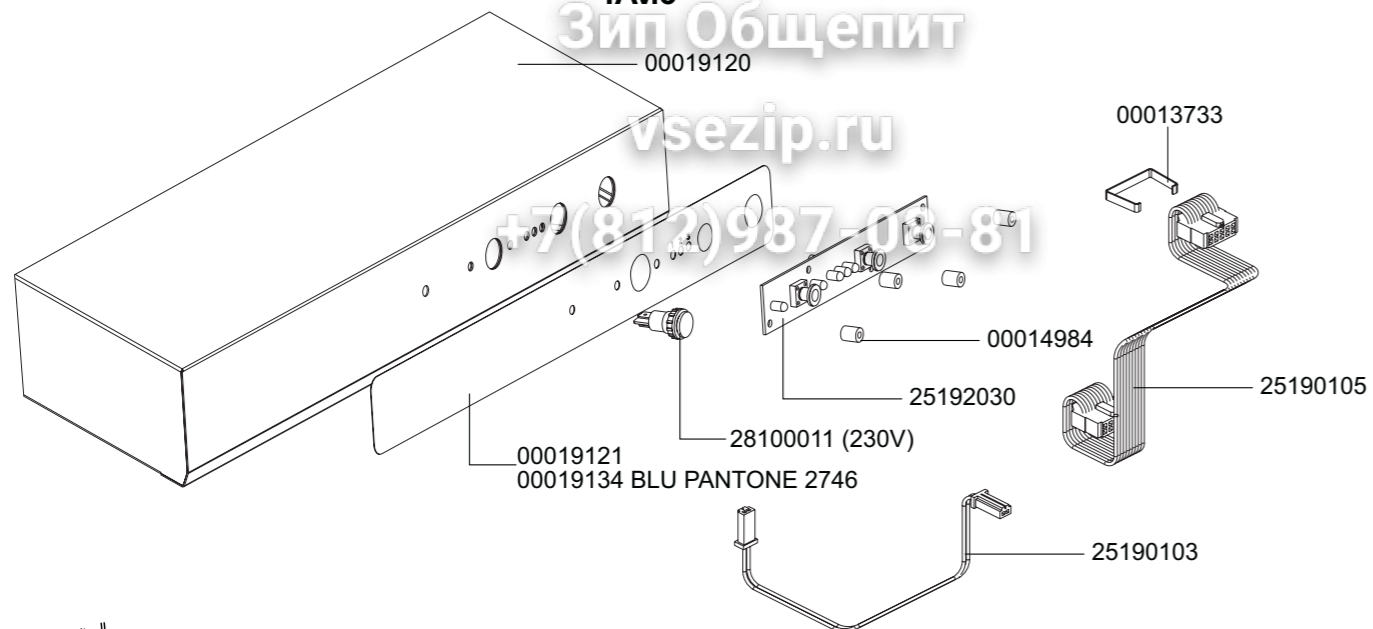

20160060 60Hz
20160053 50Hz

Pos.	Codice
1	00019540
2	00019541
3	00019542
4	06150011
7	24100001

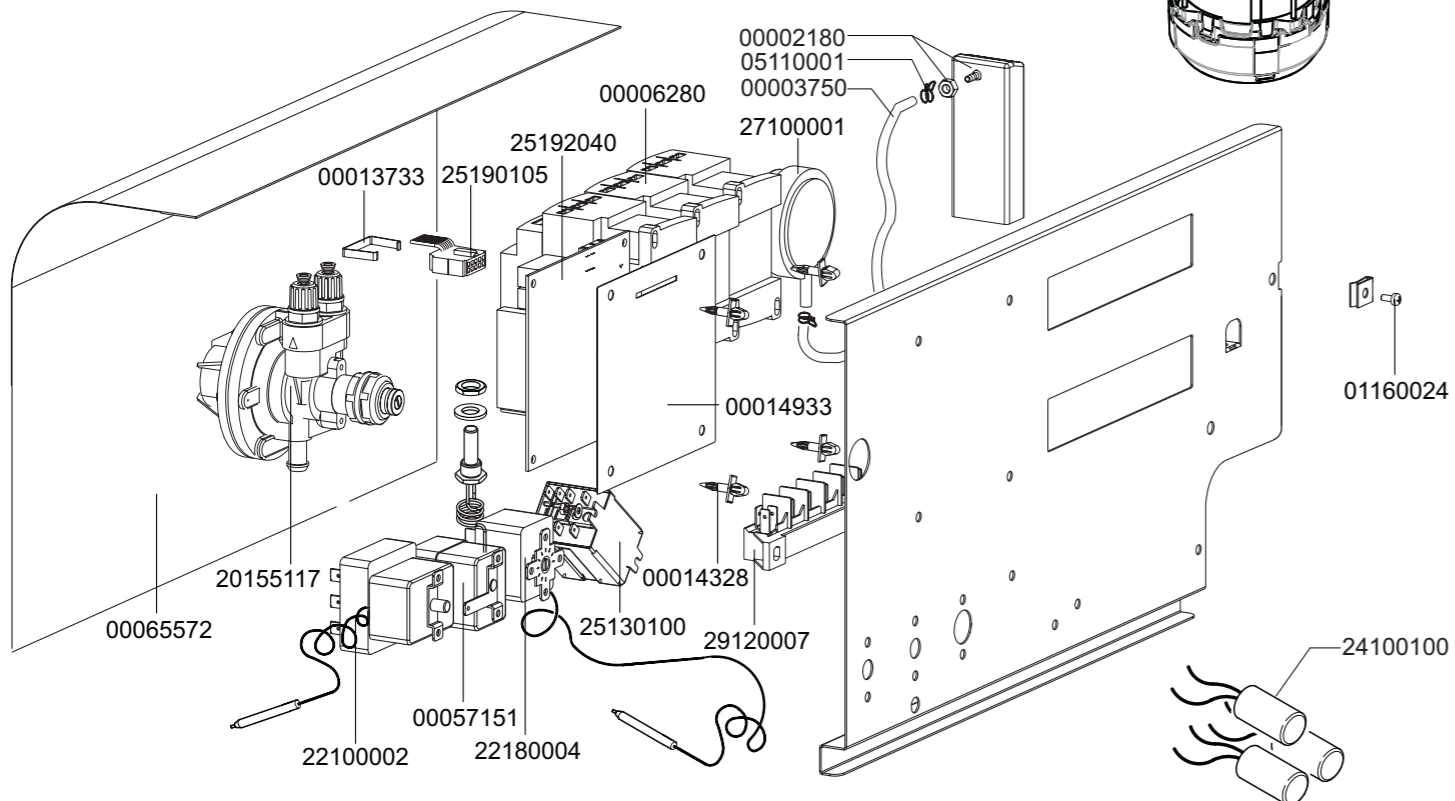
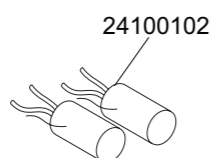
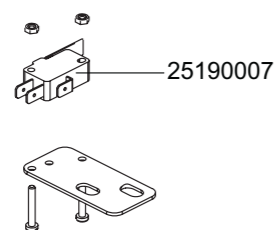
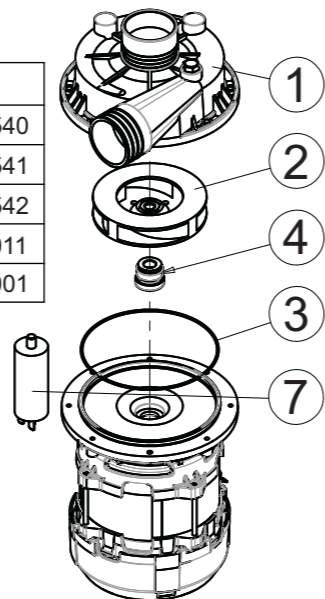

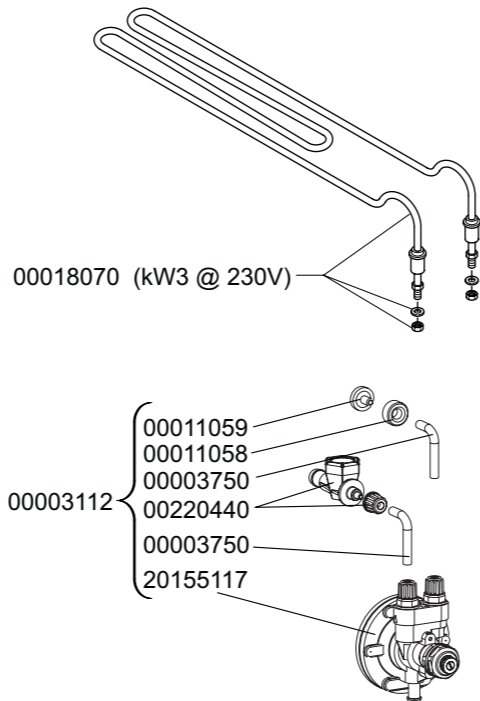
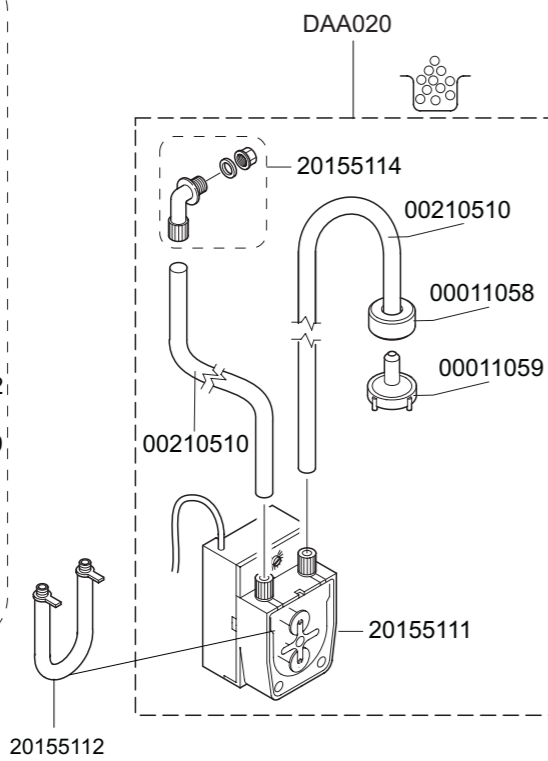
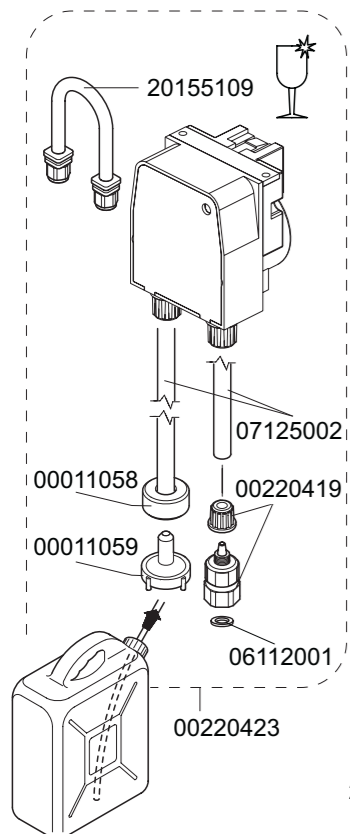
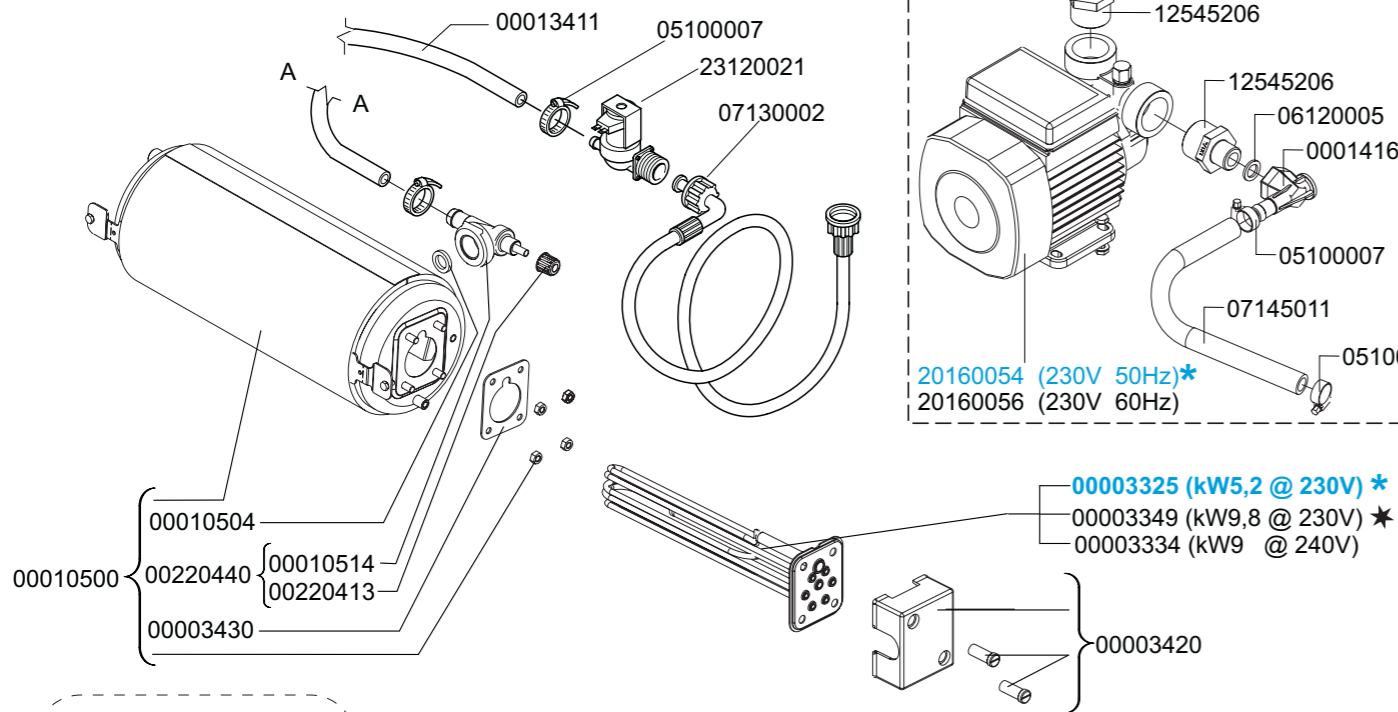
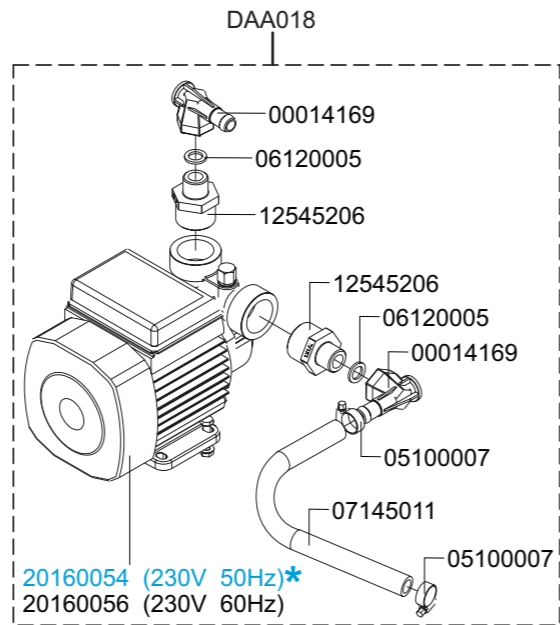
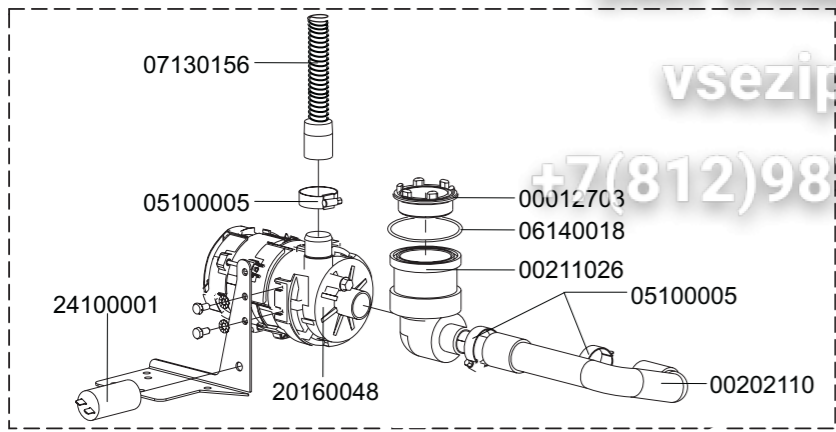

ТАV.5
Зип Общепит

vsezip.ru

+7(812)987-08-81

00007040

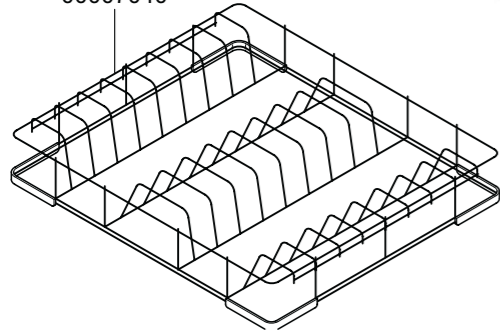

00006920

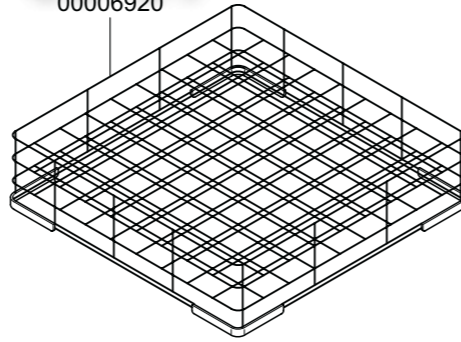

00206721

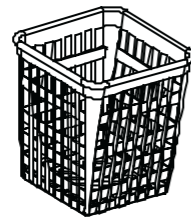

00007120

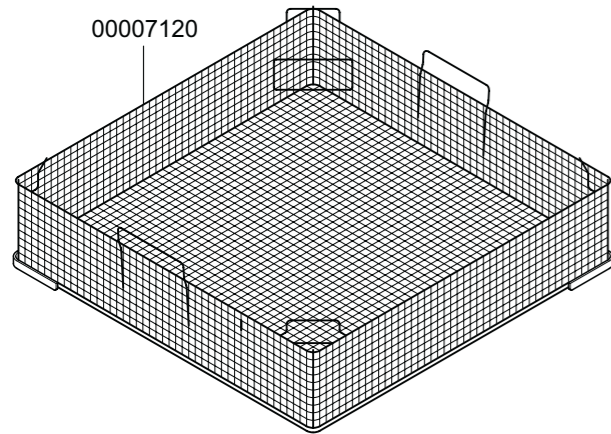

FAA007

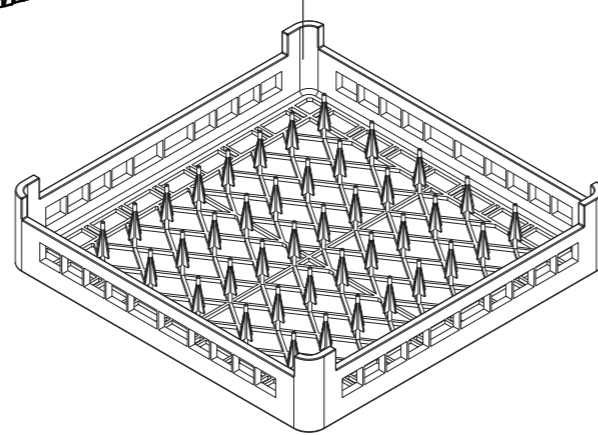

00206751

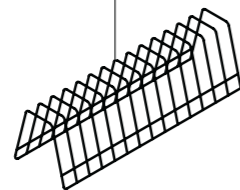

FAA031

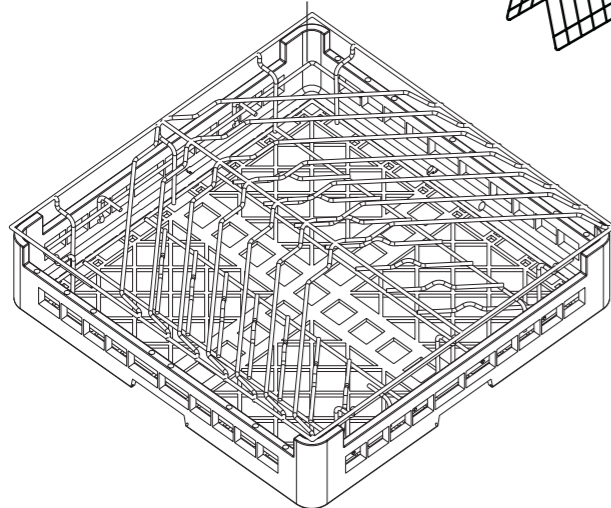

FAA001

