

Зип Общепит

vsezip.ru

DESPIECE TECNICO

+7(812)987-08-81

Sarten basculante
Sauteuse basculante
Tilting bratt pan
Kippbratpfannen
Brasiera

SERIE 900

Modelos:

SBG 9-10

SBG 9-10S

SBG 9-10I

SBG 9-10 I S

SBG 9-10 M

SBG 9-10 M S

SBG 9-10 I M

SBG 9-10 I M S

SBG 9-15 I M

SBG 9-15 I M S

SBE 9-10

SBE 9-10S

SBE 9-10I

SBE 9-10 I S

SBE 9-10 M

SBE 9-10 M S

SBE 9-10 I M

SBE 9-10 I M S

SBE 9-15 I M

SBE 9-15 I M S

Junio 2002 June



Fagor Industrial

Зип Обществ

ysezip.ru

+7(812)987-08-81

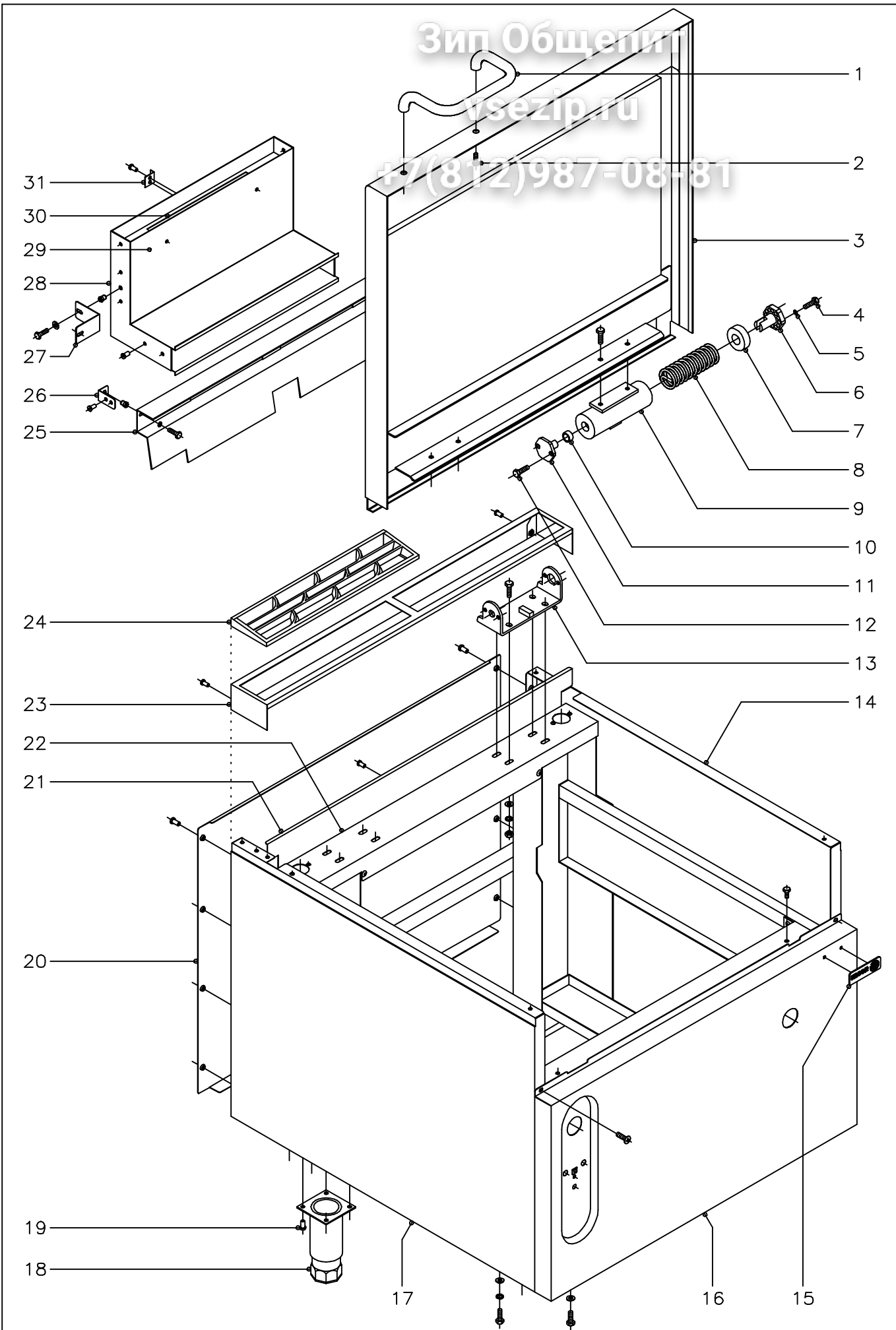

N plano C-1197	Firma 	Fecha 6-2002	Aparato MUEBLE SARTEN BASCULANTE 900	Lamina 1	Fagor Industrial S.Coop.  Onate
-------------------	--	-----------------	--	-------------	---

Зип Ощепит

vsezip.ru

+7(812)987-08-81

MOD.		SARTENES BASCULANTES GAMA 900		ZONA	MUEBLE							
ITEM	CODIGO	DENOMINACION	TEXTO	SBG9-10	SBG9-10 M	SBG9-10 S	SBG9-10 M S	SBE9-10	SBE9-10 M	SBE9-10 S	SBE9-10 M S	SBG9-15 M
1	S036123	Asa de tapa		1		1		1		1		
2	X152809	Tornillo sujecion asa tapa M-8x15		2		2		2		2		
3	X152843	Tapa completa 1 M.		1		1		1		1		-
3	X282820	Tapa completa 1,5 M.		-		-		-		-		1
4	Q012042	Tornillo exagonal M-6x15		4		4		4		4		4
5	Q262040	Arandela muelle A-6		4		4		4		4		4
6	S116120	Tensor resorte		2		2		2		2		2
7	S116118	Casquillo		2		2		2		2		2
8	S116121	Resorte tapa		2		2		2		2		2
9	X156101	Bisagra		2		2		2		2		2
	Q012051	Tornillo exagonal M-8x10		4		4		4		4		4
10	S116126	Cojinete cilindrico		2		2		2		2		2
11	S116119	Giro de asa		2		2		2		2		2
12	Q012041	Tornillo exagonal M-6x10		4		4		4		4		4
13	X286102	Soporte de bisagra		2		2		2		2		2
	Q012053	Tornillo exagonal M-8x20		8		8		8		8		8
	Q232050	Arandela plana A-8		8		8		8		8		8
	Q262050	Arandela muelle A-8		8		8		8		8		8
	Q162050	Tuerca exagonal M-8		8		8		8		8		8
14	X152836	Panel lateral derecho		1		-		1		-		1
14	X242820	Panel lateral derecho suspendido		-		1		-		1		-
	Q012042	Tornillo exagonal M-6x15		4		4		4		4		4
	Q262040	Arandela muelle A-6		4		4		4		4		4
	Q302022	Arandela plana Ø16xØ6x1,2		4		4		4		4		4
15	U262806	Escudo FAGOR		1		1		1		1		1
	Q221023	Clip sujecion escudo		2		2		2		2		2
16	X152839	Panel frontal SBG9-10		1		1		-		-		-
16	X342805	Panel frontal SBG9-10 Motorizada		1		1		-		-		-
16	X142802	Panel frontal SBE9-10		-		-		1		1		-

MOD.		SARTENES BASCULANTES GAMA 900		ZONA	MUEBLE							
ITEM	CODIGO	DENOMINACION	TEXTO	SBG9-10	SBG9-10 M	SBG9-10 S	SBG9-10 M S	SBE9-10	SBE9-10 M	SBE9-10 S	SBE9-10 M S	SBG9-15 M
16	X142802	Panel frontal SBE9-10 Motorizada		-	-	-	-	1	-	1	-	-
16	X282816	Panel frontal SBG-15		-	-	-	-	-	-	-	-	1
16	X422801	Panel frontal SBE-15		-	-	-	-	-	-	-	-	-
	Q012042	Tornillo exagonal M-6x15		2	2	2	2	2	2	2	2	2
	Q262040	Arandela muelle A-6		2	2	2	2	2	2	2	2	2
	Q152004	Tornillo aplastado M-5x13		2	2	2	2	2	2	2	2	2
17	X152835	Panel lateral izquierdo		1	-	-	-	1	-	-	-	1
17	X242821	Panel lateral izquierdo suspendido		-	1	-	-	-	1	-	-	-
	Q012042	Tornillo exagonal M-6x15		4	4	4	4	4	4	4	4	4
	Q262040	Arandela muelle A-6		4	4	4	4	4	4	4	4	4
	Q302022	Arandela plana Ø16xØ6x1,2		4	4	4	4	4	4	4	4	4
18	X260151	Pata regulable		4	-	-	-	4	-	-	-	4
19	Q411304	Remache avibulb Ø4,8		16	-	-	-	16	-	-	-	16
20	U562853	Panel posterior SB-10		1	-	-	-	1	-	-	-	-
20	S372816	Panel posterior SB-10 suspendido		-	1	-	-	-	1	-	-	-
20	U582852	Panel posterior SB-15		-	-	-	-	-	-	-	-	1
20	X412802	Panel posterior SB-15 suspendido		-	-	-	-	-	-	-	-	-
	Q419005	Remache tubular Ø4x8		8	8	8	8	8	8	8	8	8
21	X152638	Liston posterior SB-10		1	1	1	1	1	1	1	1	-
21	X282613	Liston posterior SB-15		-	-	-	-	-	-	-	-	1
	Q419005	Remache tubular Ø4x8		5	5	5	5	5	5	5	5	5
22	X150100	Armazon completo SB-10		1	-	-	-	1	-	-	-	-
22	X240100	Armazon completo SB-10 S		-	1	-	-	-	1	-	-	-
22	X420100	Armazon completo SB-15		-	-	-	-	-	-	-	-	1
22	X440100	Armazon completo SB-15 S		-	-	-	-	-	-	-	-	-
23	R205428	Soporte embellecedor 1 M.		1	1	1	1	1	1	1	1	-
23	R205430	Soporte embellecedor 1,5 M.		-	-	-	-	-	-	-	-	1
	Q419005	Remache tubular Ø4x8		2	2	2	2	2	2	2	2	2
24	R205425	Embellecedor chimenea		2	2	2	2	2	2	2	2	3

Зип Общепит

vsezip.ru

+7(812)987-08-81

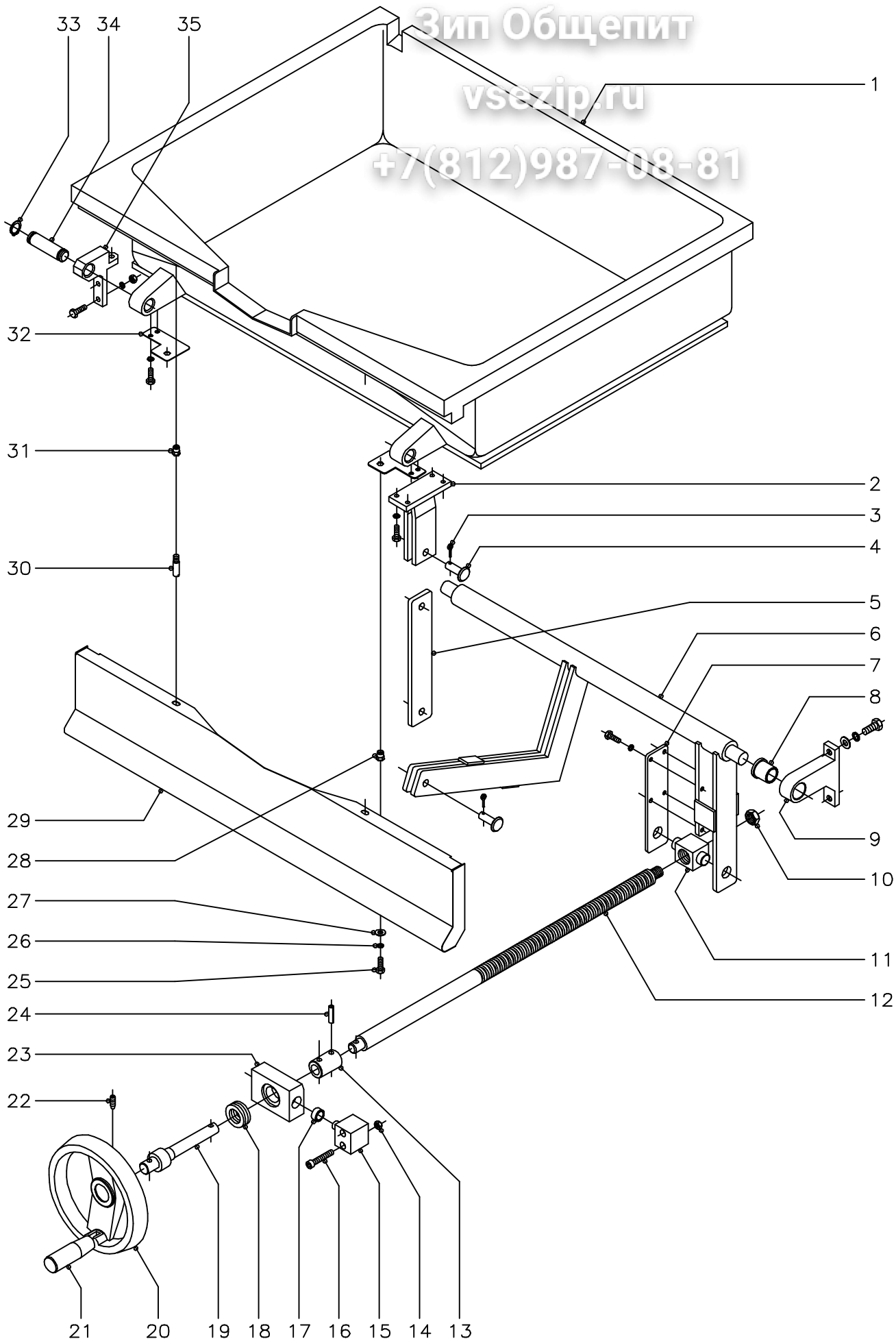

N plano	Firma	Fecha	Aparato	CUBA	Lamina	Fagor Industrial S.Coop. FAGOR
C-1198		6-2002	SARTEN BASCULANTE 900 (Elev.Manual)		2	Onate

Зип Ощепит

vsezip.ru

+7(812)987-08-81

MOD.		SARTENES BASCULANTES GAMA 900		ZONA	CUBA (Elevacion Manual)			
ITEM	CODIGO	DENOMINACION	TEXTO	SBG9-10	SBG9-10 I	SBE9-10	SBE9-10 I	
1	X156155	Cuba SBG9-10		1	-	-	-	
1	X156150	Cuba SBG9-10 I		-	1	-	-	
1	X146125	Cuba SBE9-10		-	-	1	-	
1	X146126	Cuba SBE9-10 I		-	-	-	1	
2	X156157	Horquilla de giro		1	-	1	-	
	Q262040	Arandela muelle A-6		4	-	4	-	
	Q012042	Tornillo exagonal M-6x15		4	-	4	-	
2	-	Horquilla de giro (soldado a cuba)		-	1	-	1	
3	Q352024	Pasador de aletas Ø4x25		2	2	2	2	
4	X156123	Bulon Ø12		2	2	2	2	
5	X156151	Brazo		1	1	1	1	
6	X156148	Brazo elevador		1	1	1	1	
7	X156149	Brazo lateral		1	1	1	1	
	Q012042	Tornillo exagonal M-6x15		4	4	4	4	
	Q262040	Arandela muelle A-6		4	4	4	4	
8	X109550	Cojinete		2	2	2	2	
9	X150108	Soporte giro		2	2	2	2	
	Q232060	Arandela plana A-10		4	4	4	4	
	Q261060	Arandela muelle A-10		4	4	4	4	
	Q012063	Tornillo exagonal M-10x20		4	4	4	4	
10	Q222015	Tuerca exagonal 3/8"		1	1	1	1	
11	X156154	Tuerca de husillo		1	1	1	1	
12	X156152	Husillo		1	1	1	1	
13	X156115	Casquillo		1	1	1	1	
14	Q162040	Tuerca exagonal M-6		4	4	4	4	
15	X156113	Pivote de giro		2	2	2	2	
16	Q052046	Tornillo allem M-6x40		4	4	4	4	
17	S116126	Cojinete cilindrico		2	2	2	2	
18	X156125	Rodamiento		1	1	1	1	

Зип Общепит

vsezip.ru

+7(812)987-08-81

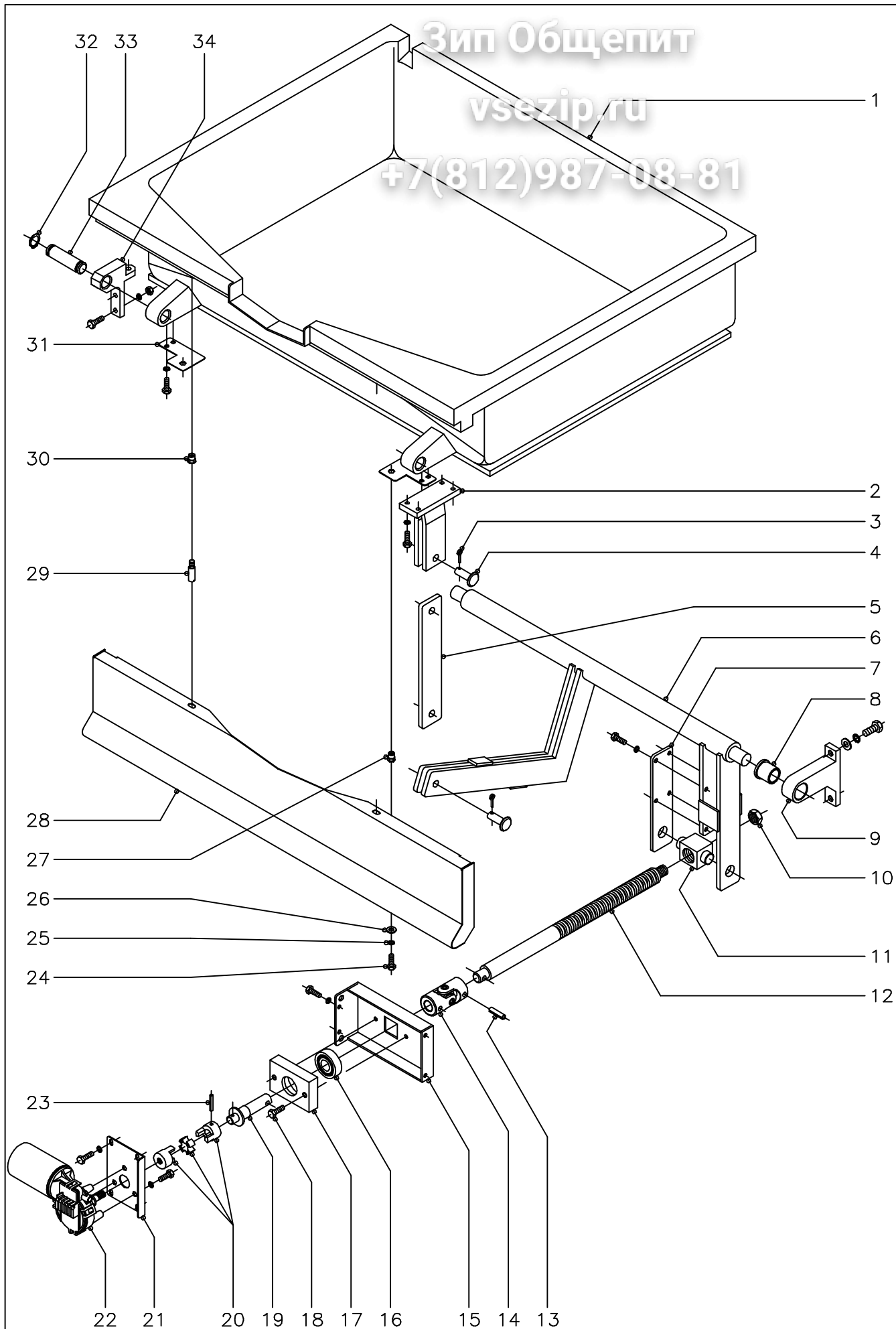

N plano
C-1199

Firma

Fecha
6-2002

Aparato
SARTEN BASCULANTE 900 (Elev.Motor)

CUBA

Lamina
3

Fagor Industrial S.Coop. **FAGOR**
Onate

Зип Ощепит

vsezip.ru

+7(812)987-08-81

MOD.		SARTENES BASCULANTES GAMA 900		ZONA	CUBA (Elevacion Motor)				
ITEM	CODIGO	DENOMINACION	TEXTO	SBG9-10 M	SBG9-10 I M	SBE9-10 M	SBE9-10 I M	SBG9-15 I M	
1	X156155	Cuba SBG9-10		1	-	-	-		
1	X156150	Cuba SBG9-10 I		-	1	-	-		
1	X146125	Cuba SBE9-10		-	-	1	-		
1	X146126	Cuba SBE9-10 I		-	-	-	1		
1	X286105	Cuba SBG9-15 I		-	-	-	-	1	
1	X426102	Cuba SBE9-15 I		-	-	-	-	-	
2	X156157	Horquilla de giro		1	-	1	-	-	
	Q262040	Arandela muelle A-6		4	-	4	-	-	
	Q012042	Tornillo exagonal M-6x15		4	-	4	-	-	
2	-	Horquilla de giro (soldada a cuba)		-	1	-	1	1	
3	Q352024	Pasador de aletas Ø4x25		2	2	2	2	2	
4	X156123	Bulon Ø12		2	2	2	2	2	
5	X156151	Brazo		1	1	1	1	1	
6	X156148	Brazo elevador		1	1	1	1	-	
6	X286106	Brazo elevador		-	-	-	-	1	
6	X426103	Brazo elevador		-	-	-	-	-	
7	X156149	Brazo lateral		1	1	1	1	1	
	Q012042	Tornillo exagonal M-6x15		4	4	4	4	4	
	Q262040	Arandela muelle A-6		4	4	4	4	4	
8	X109550	Cojinete		2	2	2	2	2	
9	X150108	Soporte giro		2	2	2	2	2	
	Q232060	Arandela plana A-10		4	4	4	4	4	
	Q261060	Arandela muelle A-10		4	4	4	4	4	
	Q012063	Tornillo exagonal M-10x20		4	4	4	4	4	
10	Q222015	Tuerca exagonal 3/8"		1	1	1	1	1	
11	X156154	Tuerca de husillo		1	1	1	1	1	
12	X156152	Husillo		1	1	1	1	1	
13	Q371027	Manguito Ø8x30		2	2	2	2	2	
14	X126114	Junta universal		1	1	1	1	1	

MOD.	SARTENES BASCULANTES GAMA 900		ZONA	CUBA (Elevacion Motor)				
ITEM	CODIGO	DENOMINACION	TEXTO	SBG9-10 M	SBG9-10 I M	SBE9-10 M	SBE9-10 I M	SBG9-15 I M
15	X342607	Soporte eje motor		1	1	1	1	1
	Q012032	Tornillo exagonal M-5x15		4	4	4	4	4
	Q262030	Arandela muelle A-5		4	4	4	4	4
16	X346109	Rodamiento SKF		1	1	1	1	1
17	X346105	Soporte rodamiento		1	1	1	1	1
18	Q012044	Tornillo exagonal M-6x25		2	2	2	2	2
19	X346106	Eje motor		1	1	1	1	1
20	X346107	Acoplamiento elastico		1	1	1	1	1
21	X342603	Soporte motor		1	1	1	1	1
	Q012042	Tornillo exagonal M-6x15		4	4	4	4	4
	Q262040	Arandela muelle A-6		4	4	4	4	4
22	X343020	Motorreductor elevacion cuba		1	1	1	1	1
	Q012042	Tornillo exagonal M-6x15		3	3	3	3	3
	Q262040	Arandela muelle A-6		3	3	3	3	3
23	Q371032	Manguito Ø5x30		1	1	1	1	1
24	Q012042	Tornillo exagonal M-6x15		2	2	2	2	2
25	Q262040	Arandela muelle A-6		2	2	2	2	2
26	Q302022	Arandela plana Ø16xØ6x1,2		2	2	2	2	2
27	Q221343	Remache exagonal M-6		2	2	2	2	2
28	X152830	Panel portamandos (Cuba fundid.)		1	-	1	-	-
28	X152833	Panel portamandos (Cuba inox.)		-	1	-	1	-
28	X282815	Panel portamandos SB-15		-	-	-	-	1
29	Q151336	Tornillo soporte guia portamandos		2	2	2	2	2
30	Q221343	Remache exagonal M-6		-	2	-	2	2
31	X156156	Amarre panel portamandos		2	-	2	-	-
	Q262040	Arandela muelle A-6		4	-	4	-	-
	Q012042	Tornillo exagonal M-6x15		4	-	4	-	-
32	Q301020	Anillo seguridad Ø20x1,2		4	4	4	4	4
33	X109511	Bulon		2	2	2	2	2

Зип Общепит

vsezip.ru

+7(812)987-08-81

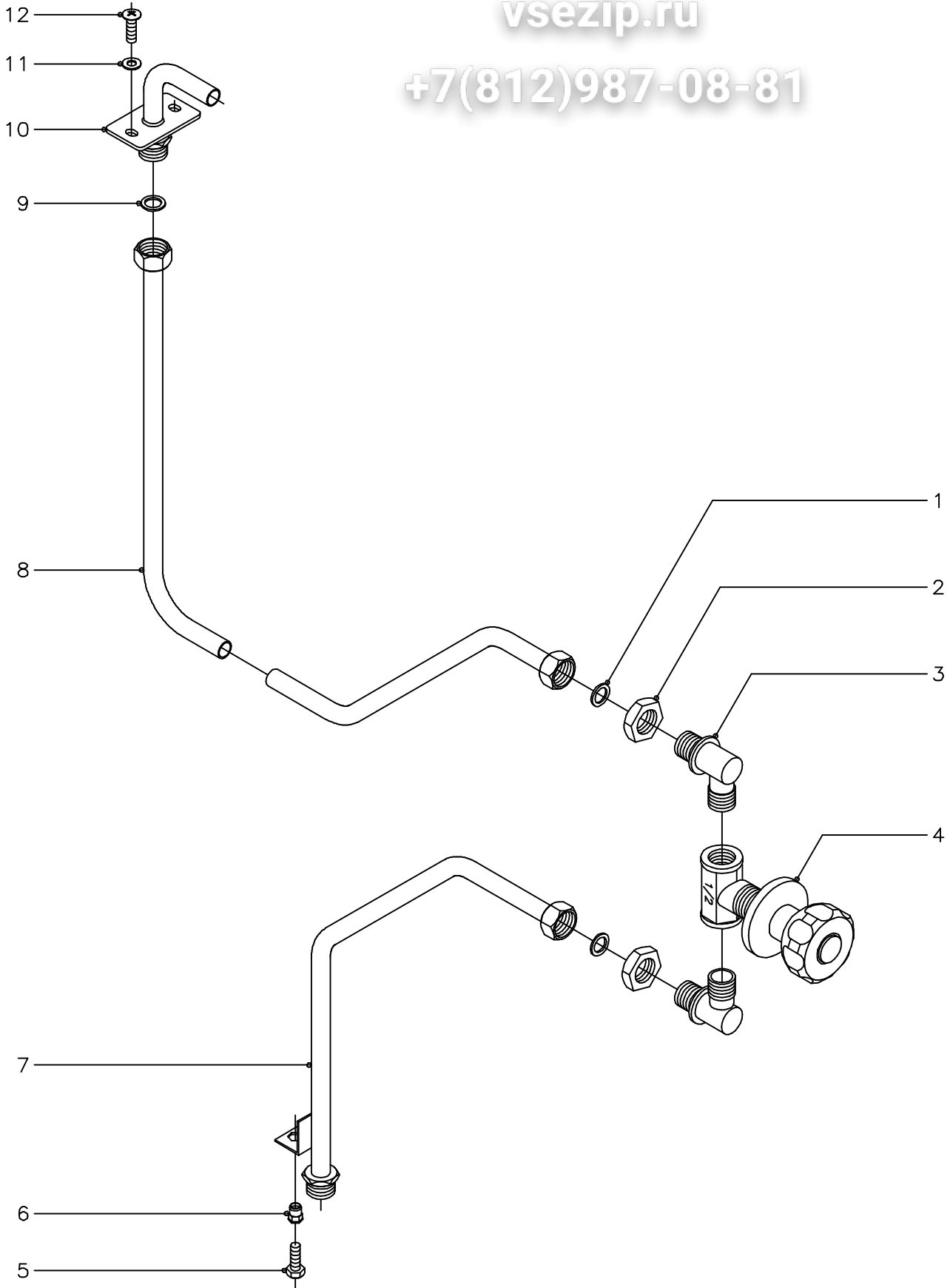

N plano
C-1200

Firma

Fecha
6-2002

Aparato
TOMA DE AGUA
SARTEN BASCULANTE 900

Lamina
4

Fagor Industrial S.Coop. **FAGOR**
Oñate

Зип Общепит

vsezip.ru

+7(812)987-08-81

MOD.		SARTENES BASCULANTES GAMA 900		ZONA	TOMA DE AGUA					
ITEM	CODIGO	DENOMINACION	TEXTO	SG9-10	SB9-15	SB9-10 S	SB9-15 S			
1	Q306024	Arandela junta Ø18xØ12,5x1,5		2	2					
2	Q221302	Tuerca exagonal 1/2" Gas		2	2					
3	S115013	Codo		2	2					
4	S112151	Llave de paso 1/2" con mando		1	1					
5	Q012042	Tornillo exagonal M-6x15		1	1					
6	Q221343	Remache exagonal M-6		1	1					
7	X155038	Conduccion entrada de agua		1	-					
7	X245017	Conduccion entrada de agua susp.		-	1					
8	X155040	Conduccion agua a tubo llenado		1	1					
9	Q306024	Arandela junta Ø18xØ12,5x1,5		1	1					
10	X156140	Conjunto tubo de llenado		1	1					
11	Q232030	Arandela plana A-5		2	2					
12	Q152004	Tornillo aplastado M-5x13		2	2					

Зип Ощепит

vsezip.ru

+7(812)987-08-81

MOD.		SARTENES BASCULANTES GAMA 900		ZONA	PARTE FUNCIONAL GAS			
ITEM	CODIGO	DENOMINACION	TEXTO	SBG9-10	SBG9-15			
1	X155720	Deflector largo		3	6			
1	X155721	Deflector corto		1	1			
2	Q419005	Remache tubular Ø4x8		8	14			
3	X155710	Quemador		1	-			
3	X285710	Quemador		-	1			
4	Q012031	Tornillo exagonal M-5x10		2	2			
5	U325707	Regulador de aire		2	2			
6	U052401	Tobera Ø1,45 (Butano Propano)		2	3			
6	U262400	Tobera Ø2,15 (Gas Natural)		2	3			
6	X102403	Tobera Ø4,58 (Gas Villa)		2	3			
7	X155035	Tubo de encendido		1	1			
8	Q012031	Tornillo exagonal M-5x10		2	2			
9	Q221324	Tuerca exagonal 3/4"		1	1			
10	Q306027	Arandela plana Ø33,8x27x1,5		1	1			
11	S112804	Embelledor tubo de encendido		1	1			
12	X155030	Conduccion a quemador		1	-			
12	X285015	Conduccion a quemador		-	1			
	Q012031	Tornillo exagonal M-5x10		4	4			
13	Q153002	Tornillo tapon		2	3			
14	U562130	Termopar L=850		1	1			
15	X155032	Tubo piloto		1	-			
15	X285017	Tubo piloto		-	1			
16	U195009	Manguito empalme		1	1			
17	X205028	Bicono Ø6		1	1			
18	X012104	Manguito para racord 1/2"		2	2			
19	X012105	Bicono Ø16		2	2			
20	X162101	Racord 1/2"		2	2			
21	X155043	Tubo piloto a valvula		1	1			
22	U195009	Manguito empalme		1	1			

MOD.	SARTENES BASCULANTES GAMA 900		ZONA	PARTE FUNCIONAL GAS				
ITEM	CODIGO	DENOMINACION	TEXTO	SBG9-10	SBG9-15			
23	X205028	Bicono Ø6		1	1			
24	X153004	Codo 1/2" SIT		2	2			
		Junta torica		2	2			
		Tornillo amarre codo		8	8			
25	X262100	Alargadera pulsador		1	1			
26	X163000	Electrovalvula 820 nova (50 Hz.)		1	1			
	X163020	Bobina para electrovalvula (60 Hz.)		1	1			
27	R275027	Cableado electrosit		1	1			
28	U565007	Codo entrada gas		1	1			
29	U725006	Tuerca 3/4"		1	1			
30	Q306052	Arandela junta Ø23,5x15,5x3		1	1			
31	Q012042	Tornillo exagonal M-6x15		1	1			
	Q221343	Remache exagonal M-6		1	1			
32	X012101	Bujia de encendido		1	1			
33	X155033	Conduccion entrada gas		1	1			
34	U134323	Racord c/bicono Ø6		1	1			
35	U322118	Piloto completo		1	1			
36	Q221342	Remache exagonal M-5		2	2			
37	Q302022	Arandela plana Ø16xØ6x1,2		2	2			
38	Q012031	Tornillo exagonal M-5x10		2	2			

Зип Общепит

vsezip.ru

+7(812)987-08-81

MOD.		SARTENES BASCULANTES GAMA 900		ZONA	PARTE FUNCIONAL ELECTRICA (GA				
ITEM	CODIGO	DENOMINACION	TEXTO	SBG9-10	SBG9-10 I	SBG9-10 M	SBG9-10 I M	SBG9-15 I M	
1	X143017	Piloto verde		1	1	1	1		
2	X143018	Piloto ambar		1	1	1	1		
3	Q262030	Arandela muelle A-5		1	1	1	1		
4	Q152004	Tornillo aplastado M-5x13		1	1	1	1		
	Q221342	Remache exagonal M-5		1	1	1	1		
5	X152111	Boton de mando Ø6		1	1	1	1		
	Q281000	Anillo de compresion mando		1	1	1	1		
6	X152667	Tapa caja		1	1	1	1		
7	X343021	Transformador		-	-	1	1		
	Q012031	Tornillo exagonal M-5x10		-	-	4	4		
	Q302022	Arandela plana Ø16xØ6x1,2		-	-	4	4		
	Q221342	Remache exagonal M-5		-	-	4	4		
	X342605	Tapa transformador		-	-	1	1		
	X342606	Caja transformador		-	-	1	1		
	Q012031	Tornillo exagonal M-5x10		-	-	4	4		
	Q302022	Arandela plana Ø16xØ6x1,2		-	-	4	4		
	X342609	Escuadra amarre tapa transforma.		-	-	1	1		
	Q419005	Remache tubular Ø4x8		-	-	4	4		
8	X343022	Puente rectificador		-	-	1	1		
	Q152004	Tornillo aplastado M-5x13		-	-	1	1		
	Q221342	Remache exagonal M-5		-	-	1	1		
9	X343009	Pulsador doble con protector		-	-	1	1		
	X342608	Soporte pulsador		-	-	1	1		
	Q012042	Tornillo exagonal M-6x15		-	-	4	4		
	Q162040	Tuerca exagonal M-6		-	-	4	4		
	Q302022	Arandela plana Ø16xØ6x1,2		-	-	4	4		
10	X342602	Soporte micro		-	-	1	1		
	Q012031	Tornillo exagonal M-5x10		-	-	2	2		
	Q262030	Arandela muelle A-5		-	-	2	2		

MOD.		SARTENES BASCULANTES GAMA 900		ZONA	PARTE FUNCIONAL ELECTRICA (GA				
ITEM	CODIGO	DENOMINACION	TEXTO	SBG9-10	SBG9-10 I	SBG9-10 M	SBG9-10 I M	SBG9-15 I M	
	Q302022	Arandela plana Ø16xØ6x1,2		-	-	2	2		
	Q221342	Remache exagonal M-5		-	-	2	2		
11	X343015	Microrruptor		-	-	1	1		
12	Q222005	Tuerca exagonal M-10x0,75		-	-	1	1		
13	X152646	Proteccion superior		1	1	1	1		
	Q152024	Tornillo avellanado M-4x8		1	1	1	1		
14	X343015	Microrruptor		1	1	2	2		
15	X152681	Caja portamicro		1	1	1	1		
	Q221342	Remache exagonal M-5		2	2	2	2		
	Q302022	Arandela plana Ø16xØ6x1,2		2	2	2	2		
	Q262030	Arandela muelle A-5		2	2	2	2		
	Q012031	Tornillo exagonal M-5x10		2	2	2	2		
16	Q222005	Tuerca exagonal M-10x0,75		1	1	2	2		
17	X152680	Soporte caja portamicro		1	1	1	1		
	Q221342	Remache exagonal M-5		2	2	2	2		
	Q302022	Arandela plana Ø16xØ6x1,2		2	2	2	2		
	Q262030	Arandela muelle A-5		2	2	2	2		
	Q012031	Tornillo exagonal M-5x10		2	2	2	2		
18	Q232050	Arandela plana A-8		1	1	1	1		
19	Z700603	Muelle		1	1	1	1		
20	Q271033	Arandela de seguridad Ø6		2	2	2	2		
21	X152682	Eje pulsador micro		1	1	1	1		
22	Q223022	Tuerca exagonal M-8x1		1	1	1	1		
23	X152661	Soporte limitador		1	1	1	1		
24	Q162030	Tuerca exagonal M-5		2	2	2	2		
25	R612103	Termostato limitador		1	1	1	1		
26	X163007	Conmutador acople termostato		1	1	1	1		
	Q151320	Tornillo alomado M-4x6		2	2	2	2		
27	X313001	'U' soporte termostato		1	1	1	1		

Зип Общепит

vsezip.ru

+7(812)987-08-81

ITEM	CODIGO	DENOMINACION	TEXTO	SBG9-10	SBG9-10 I	SBG9-10 M	SBG9-10 I M	SBG9-15 I M	MOD. SARTENES BASCULANTES GAMA 900		ZONA	PARTE FUNCIONAL ELECTRICA (GA
28	X153000	Termostato		1	1	1	1					
29	R073007	Encendedor		1	1	1	1					
30	X152656	Soporte valvula (caja electrica)		1	1	1	1					
31	X342601	Cuadro regleta		1	1	1	1					
32	U183046	Regleta toma corriente		1	1	1	1					
33	R073004	Prensaestopas		2	2	2	2					
34	X342600	Tapa caja regleta		1	1	1	1					
	Q302022	Arandela plana Ø16xØ6x1,2		2	2	2	2					
	Q012042	Tornillo exagonal M-6x15		2	2	2	2					
35	Q012042	Tornillo exagonal M-6x15		4	-	4	-					
36	Q262040	Arandela muelle A-6		4	-	4	-					
37	Q012032	Tornillo exagonal M-5x15		1	1	1	1					
38	Q012033	Tornillo exagonal M-5x20		1	1	1	1					
39	X156147	Cubrebulbo		1	-	1	-					

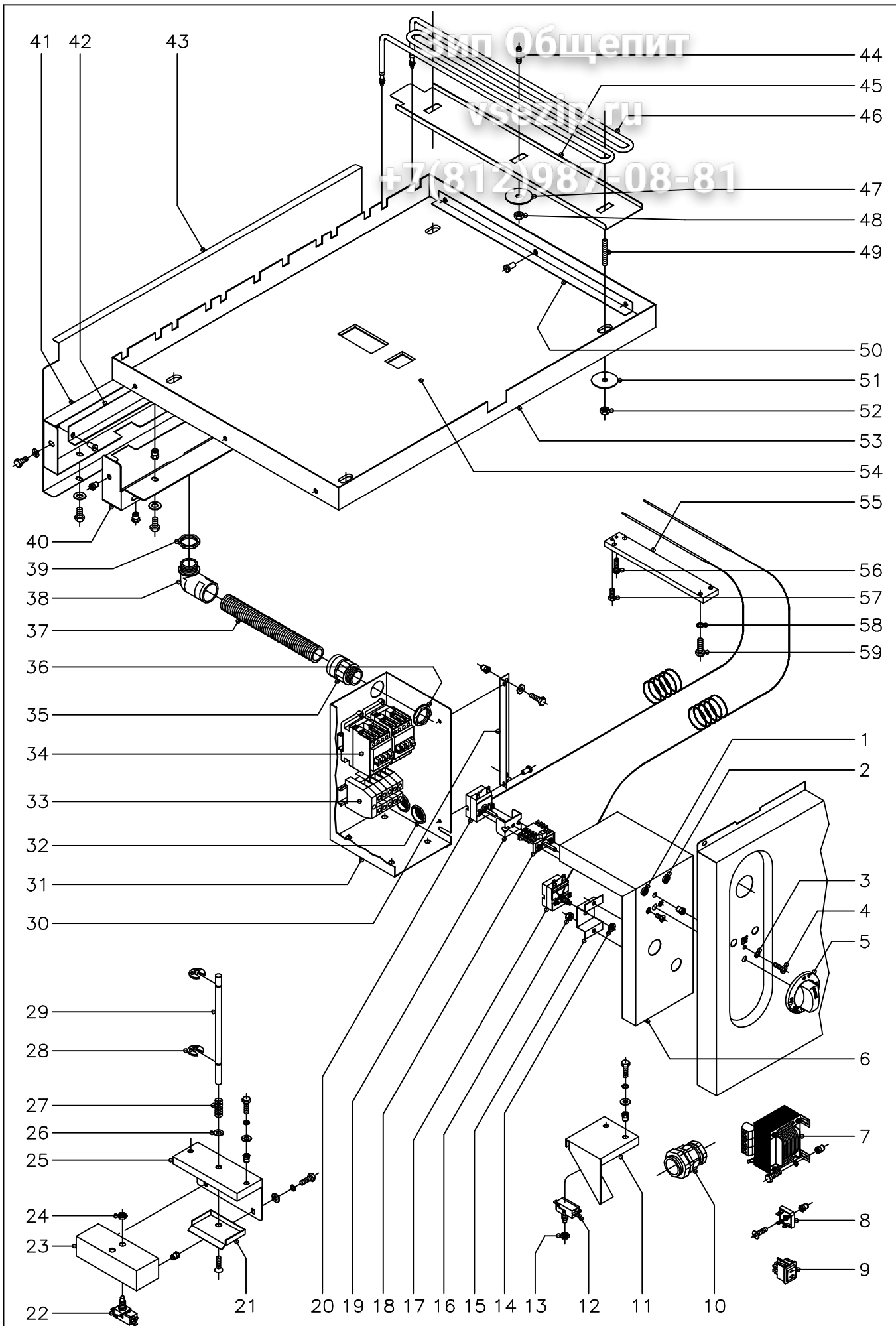

N plano	Firma	Fecha	Aparato	PARTE FUNCIONAL ELECTRICA	Lamina	Fagor Industrial S.Coop. FAGOR
C-1203		6-2002	SARTEN BASCULANTE 900 ELECTRICA	7	Oñate	

MOD.		SARTENES BASCULANTES GAMA 900		ZONA	PARTE FUNCIONAL ELECTRICA (ELECT				
ITEM	CODIGO	DENOMINACION	TEXTO	SBE9-10	SBE9-10 I	SBE9-10 M	SBE9-10 I M	SBE9-15 I M	
1	X143017	Piloto verde		1	1	1	1	1	
2	X143018	Piloto ambar		1	1	1	1	1	
3	Q262030	Arandela muelle A-5		1	1	1	1	1	
4	Q152004	Tornillo aplastado M-5x13		1	1	1	1	1	
	Q221342	Remache exagonal M-5		1	1	1	1	1	
5	U673017	Boton de mando Ø6		1	1	1	1	1	
	Q281000	Anillo de compresion mando		1	1	1	1	1	
6	X152667	Tapa caja		1	1	1	1	1	
7	X343021	Transformador		-	-	1	1	1	
	Q012031	Tornillo exagonal M-5x10		-	-	4	4	4	
	Q302022	Arandela plana Ø16xØ6x1,2		-	-	4	4	4	
	Q221342	Remache exagonal M-5		-	-	4	4	4	
	X342605	Tapa transformador		-	-	1	1	1	
	X342606	Caja transformador		-	-	1	1	1	
	Q012031	Tornillo exagonal M-5x10		-	-	4	4	4	
	Q302022	Arandela plana Ø16xØ6x1,2		-	-	4	4	4	
	X342609	Escuadra amarre tapa transforma.		-	-	1	1	1	
	Q419005	Remache tubular Ø4x8		-	-	4	4	4	
8	X343022	Puente rectificador		-	-	1	1	1	
	Q152004	Tornillo aplastado M-5x13		-	-	1	1	1	
	Q221342	Remache exagonal M-5		-	-	1	1	1	
9	X343009	Pulsador doble con protector		-	-	1	1	1	
	X342608	Soporte pulsador		-	-	1	1	1	
	Q012042	Tornillo exagonal M-6x15		-	-	4	4	4	
	Q162040	Tuerca exagonal M-6		-	-	4	4	4	
	Q302022	Arandela plana Ø16xØ6x1,2		-	-	4	4	4	
10	R033002	Prensaestopas		1	1	1	1	1	
11	X342602	Soporte micro		-	-	1	1	1	
	Q012031	Tornillo exagonal M-5x10		-	-	2	2	2	

MOD.		SARTENES BASCULANTES GAMA 900		ZONA	PARTE FUNCIONAL ELECTRICA (ELECT				
ITEM	CODIGO	DENOMINACION	TEXTO	SBE9-10	SBE9-10 I	SBE9-10 M	SBE9-10 IM	SBE9-15 IM	
	Q262030	Arandela muelle A-5		-	-	2	2	2	
	Q302022	Arandela plana Ø16xØ6x1,2		-	-	2	2	2	
	Q221342	Remache exagonal M-5		-	-	2	2	2	
12	X343015	Microrruptor		-	-	1	1	1	
13	Q222005	Tuerca exagonal M-10x0,75		-	-	1	1	1	
14	Q223022	Tuerca exagonal M-8x1		1	1	1	1	1	
15	X152661	Soporte limitador		1	1	1	1	1	
16	Q162030	Tuerca exagonal M-5		2	2	2	2	2	
17	R612103	Termostato limitador		1	1	1	1	1	
18	X163007	Conmutador acople termostato		1	1	1	1	1	
	Q151320	Tornillo alomado M-4x6		2	2	2	2	2	
19	X313001	'U' soporte termostato		1	1	1	1	1	
20	X153000	Termostato		1	1	1	1	1	
21	X152646	Proteccion superior		1	1	1	1	1	
	Q152024	Tornillo avellanado M-4x8		1	1	1	1	1	
22	X343015	Microrruptor		1	1	2	2	2	
23	X152681	Caja portamicro		1	1	1	1	1	
	Q221342	Remache exagonal M-5		2	2	2	2	2	
	Q302022	Arandela plana Ø16xØ6x1,2		2	2	2	2	2	
	Q262030	Arandela muelle A-5		2	2	2	2	2	
	Q012031	Tornillo exagonal M-5x10		2	2	2	2	2	
24	Q222005	Tuerca exagonal M-10x0,75		1	1	2	2	2	
25	X152680	Soporte caja portamicro		1	1	1	1	1	
	Q221342	Remache exagonal M-5		2	2	2	2	2	
	Q302022	Arandela plana Ø16xØ6x1,2		2	2	2	2	2	
	Q262030	Arandela muelle A-5		2	2	2	2	2	
	Q012031	Tornillo exagonal M-5x10		2	2	2	2	2	
26	Q232050	Arandela plana A-8		1	1	1	1	1	
27	Z700603	Muelle		1	1	1	1	1	

MOD.	SARTENES BASCULANTES GAMA 900		ZONA	PARTE FUNCIONAL ELECTRICA (ELECT				
ITEM	CODIGO	DENOMINACION	TEXTO	SBE9-10	SBE9-10 I	SBE9-10 M	SBE9-10 IM	SBE9-15 IM
28	Q271033	Arandela de seguridad Ø6		2	2	2	2	2
29	X152682	Eje pulsador micro		1	1	1	1	1
30	X152657	Soporte caja		1	1	1	1	1
	Q221342	Remache exagonal M-5		2	2	2	2	2
	Q302022	Arandela plana Ø16xØ6x1,2		2	2	2	2	2
	Q012031	Tornillo exagonal M-5x10		2	2	2	2	2
31	X152656	Soporte valvula (caja electrica)		1	1	1	1	1
	Q419005	Remache tubular Ø4x8		2	2	2	2	2
32	X723014	Pasamuros Ø30		2	2	2	2	2
33	P453025	Borna fases 10 (gris)		3	3	3	3	-
	Z263302	Borna neutro 10 (azul)		1	1	1	1	-
	P453026	Borna tierra 10 (amarillo-verde)		1	1	1	1	-
	Z263303	Tope final		1	1	1	1	-
33	Z683069	Borna fases 16 (gris)		-	-	-	-	3
	Z683097	Borna neutro 16 (azul)		-	-	-	-	1
	Z683070	Borna tierra 16 (amarillo-verde)		-	-	-	-	1
	Z683096	Tope final		-	-	-	-	1
	Z403016	Guia contactor L=100		1	1	1	1	1
	Q419005	Remache tubular Ø4x8		2	2	2	2	2
34	R663031	Contactador 3TF3010-OAL2		2	2	2	2	-
34	X183011	Contactador 3RT1024-1AN20		-	-	-	-	2
	Z403016	Guia contactor L=100		1	1	1	1	1
	Q419005	Remache tubular Ø4x8		2	2	2	2	2
35	X713021	Racord		1	1	1	1	1
36	X713022	Tuerca PG-21		1	1	1	1	1
37	3712300	Tubo PG-21 L=850 mm.		1	1	1	1	1
38	Z703006	Racord a 90°		1	1	1	1	1
39	X143012	Contratuerca laton		1	1	1	1	1
40	X142651	Cubierta de bornas 10		1	1	1	1	-

MOD.		SARTENES BASCULANTES GAMA 900		ZONA	PARTE FUNCIONAL ELECTRICA (ELECT				
ITEM	CODIGO	DENOMINACION	TEXTO	SBE9-10	SBE9-10 I	SBE9-10 M	SBE9-10 IM	SBE9-15 IM	
40	X422616	Cubierta de bornas 15		-	-	-	-	1	
	Q221342	Remache exagonal M-5		3	3	3	3	4	
	Q302022	Arandela plana Ø16xØ6x1,2		3	3	3	3	4	
	Q012032	Tornillo exagonal M-5x15		3	3	3	3	4	
41	X142652	Tapa cubierta bornas 10		1	1	1	1	-	
41	X422617	Tapa cubierta bornas 15		-	-	-	-	1	
	Q221342	Remache exagonal M-5		2	2	2	2	2	
	Q302022	Arandela plana Ø16xØ6x1,2		2	2	2	2	2	
	Q012032	Tornillo exagonal M-5x15		2	2	2	2	2	
42	X402601	Escuadra separador resistencias		2	2	2	2	3	
	Q419005	Remache tubular Ø4x8		4	4	4	4	6	
43	X142653	Proteccion agua cuba 10		1	1	1	1	-	
43	X422618	Proteccion agua cuba 15		-	-	-	-	1	
	Q221342	Remache exagonal M-5		3	3	3	3	4	
	Q302022	Arandela plana Ø16xØ6x1,2		3	3	3	3	4	
	Q012032	Tornillo exagonal M-5x15		3	3	3	3	4	
44	Q131555	Varilla roscada M-8x30		14	14	14	14	21	
45	X142620	Amarre resistencias		6	6	6	6	9	
46	X143010	Resistencia (2000 W., 230 V.)		6	6	6	6	9	
47	Q302024	Arandela plana Ø44xØ9x1,5		14	14	14	14	21	
48	Q162050	Tuerca exagonal M-8		14	14	14	14	21	
49	Q131558	Varilla roscada M-8x60		4	4	4	4	6	
50	X142609	Amarre aislante		3	3	3	3	3	
	Q419005	Remache tubular Ø4x8		9	9	9	9	9	
51	Q302024	Arandela plana Ø44xØ9x1,5		4	4	4	4	6	
52	Q162050	Tuerca exagonal M-8		4	4	4	4	6	
53	X142650	Cubierta resistencias 10		1	1	1	1	-	
53	X422615	Cubierta resistencias 15		-	-	-	-	1	
54	X142656	Aislante cubierta barlan 730x520x5		1	1	1	1	-	

Зип Общепит

vsezip.ru

+7(812)987-08-81

MOD.		SARTENES BASCULANTES GAMA 900		ZONA	PIEZAS ESPECIFICAS PARA LOS DISTINTO			
ITEM	CODIGO	DENOMINACION	TEXTO	SBG9-10	SBG9-15			
		<u>BUTANO-PROPANO</u>						
6	U052401	Tobera quemador Ø1,45		2	3			
35	U442138	Inyector piloto Ø0,25		1	1			
		<u>GAS NATURAL</u>						
6	U262400	Tobera quemador Ø2,15		2	3			
35	U442137	Inyector piloto Ø0,40		1	1			
		<u>GAS VILLA</u>						
6	X102403	Tobera quemador Ø4,58		2	3			
35	U442138	Inyector piloto Ø0,25		1	1			

Зип Общепит

vsezip.ru

+7(812)987-08-81

	MOD.	SARTENES BASCULANTES GAMA 900	ZONA	VARIOS (SARTENES ELECTRICAS					
ITEM	CODIGO	DENOMINACION	TEXTO	SBE9-10	SBE9-10 M	SBE9-15 I M			
	X146511	Folleto de instrucciones		1	1	1			
	X143006	Esquema electrico adhesivo		1	-	-			
	X403002	Esquema electrico adhesivo		-	1	1			
	X143005	Esquema electrico de montaje		1	1	1			
	X143015	Instalacion electrica		1	1	1			
	X143004	Cableado resistencias 10		1	1	-			
	X423004	Cableado resistencias 15		-	-	1			
	X143016	Cableado regleta a contactores 10		2	2	-			
	X423005	Cableado regleta a contactores 15		-	-	2			
	X283000	Cableado motorreductor elevacion		-	1	1			

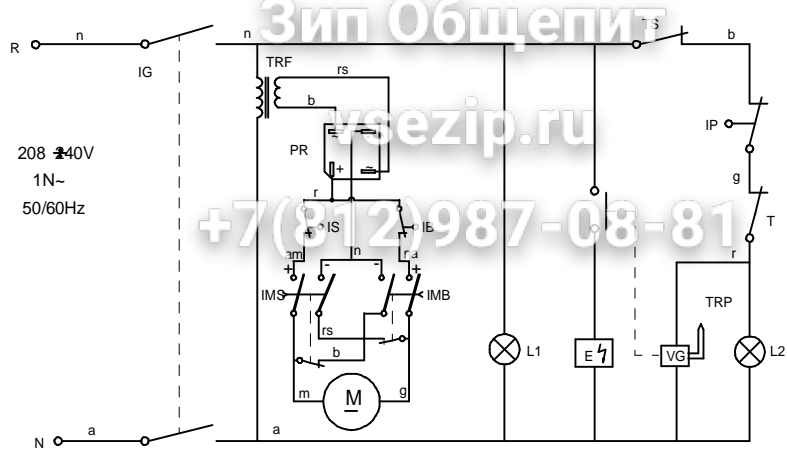

SBG9-10M, SBG9-1

a: azul	a: bleu	a: blue
m: marron	m: marron	m: bro
n: negro	n: noir	n: black
r: rojo	r: rouge	r: red
b: blanco	b: blanc	b: white
g: gris	g: gris	g: grey
rs: rosa	rs: rose	rs: pink
am: amarillo	am: jaune	am: yellow
na: naranja	na: orange	na: orange
ve: verde	ve: vert	ve: green

E: Encendedor	E: Allumage	E: Igniter	E: Start
VG: Válvula gas	VG: Valve gaz	VG: Gas valve	VG: Gasventil
IB: Micro tope bajada	IB: Micro bride descente	IB: Descént tops witch	IB: Mikro-Schalter unten
IG: Interruptor general	IG: Interrupteur général	IG: Main switch	IG: Hauptschalter
IMB: Pulsador bajada	IMB: Commande de baisse	IMB: Descent switch	IMB: Kippschalter unten
IMS: Pulsador subida	IMS: Commande de montée	IMS: Elevation switch	IMS: Kippschalter oben
IP: Micro seguridad	Ip: Micro sécurité	IP: Security switch	IP: Mikro-Sicherheitsschalter
IS: Micro tope subida	Is: Micro bride montée	IS: Elevating top switch	IS: Mikro-Schalter oben
L1: Lámpara marcha	L1: Veilleuse mise en route	L1: On light	L1: Funktionsleuchte
L2: Lámpara calentamiento	L2: Veilleuse chauffage	L2: Heating light	L2: Erwärmungsleuchte
M: Motor	M: Moteur	M: Motor	M: Motor
PR: Puente rectificador	PR: Pont rectificateur	PR: Rectifier bridge	PR: Richteiterüberbrückung
T: Termostato	T: Thermostat	T: Thermostat	T: Thermostat
TRF: Transformador	TRF: Transformateur	TRF: Transformer	TRF: Transformator
TS: Termostato seguridad	TS: Thermostat sécurité	TS: Security thermostat	TS: Sicherheitsthermostat
TRP: Termopar	TRP: Termocouple	TRP: Thermo couple	TRP: Thermometer

Esquema teórico		
Nº	Pieza	
Nº	Modificacion	
Dibujado	Firma	Fecha
	KONTXI	10/1/2001
Proyectado		
Comprobado		
Escala		
SARTORIUS		
<small>Plano hau ez dateke erabil ez beriztia gure b</small>		

Зип Общепит

vsezip.ru

+7(812)987-08-81

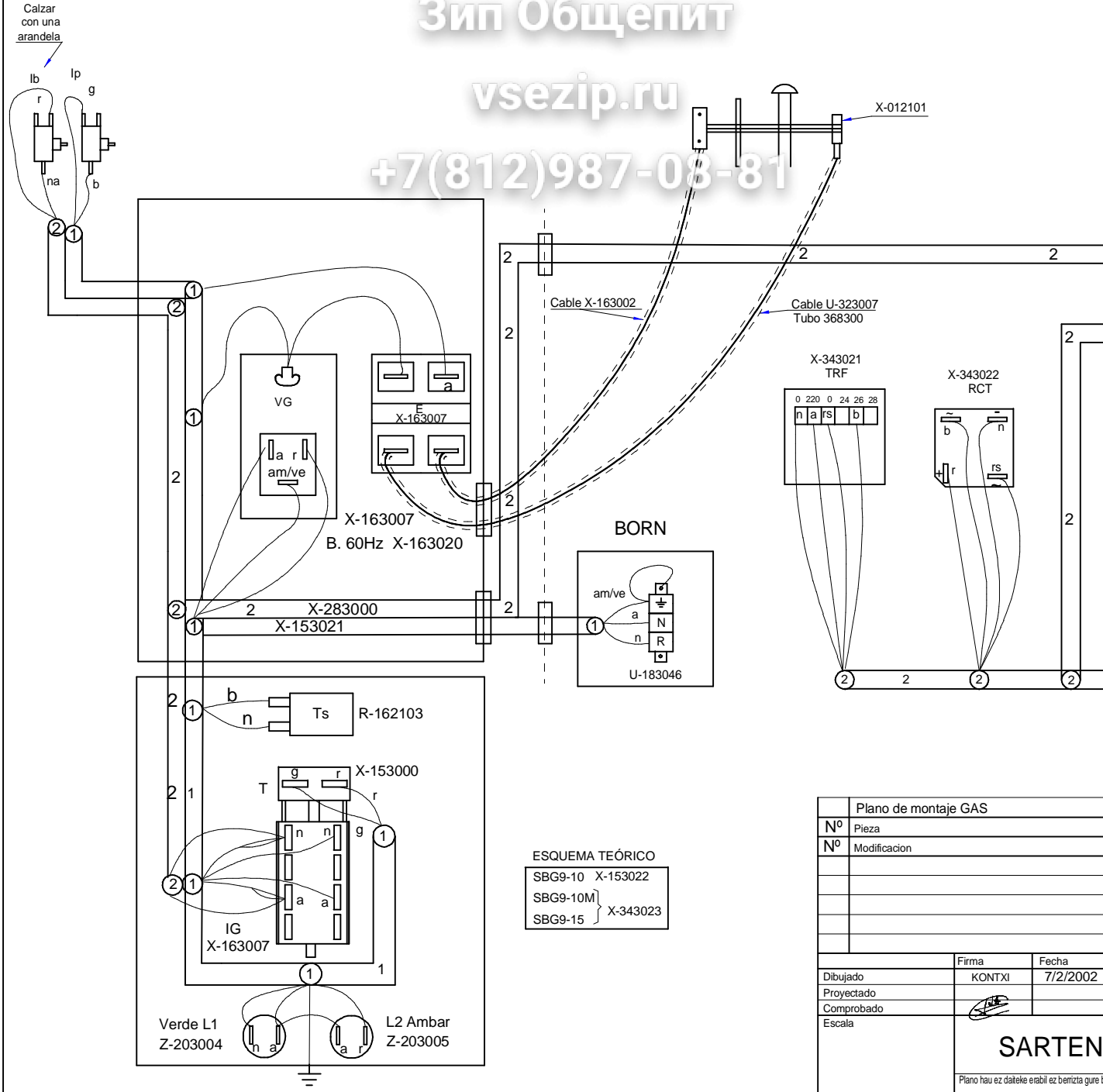

SBE9-10M

Зип Общепит

SBE9-15

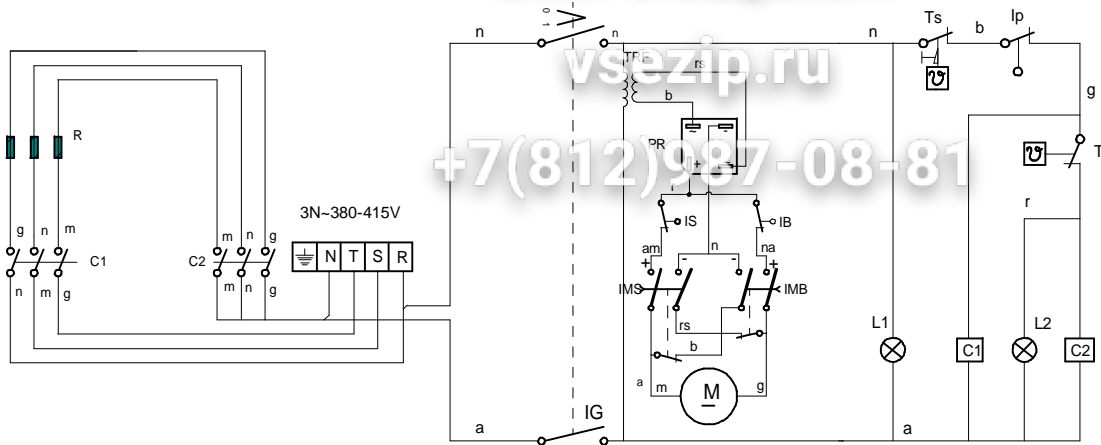

- a: azul
- m: marron
- n: negro
- r: rojo
- b: blanco
- g: gris
- rs: rosa
- am: amarillo
- na: naranja
- ve: verde

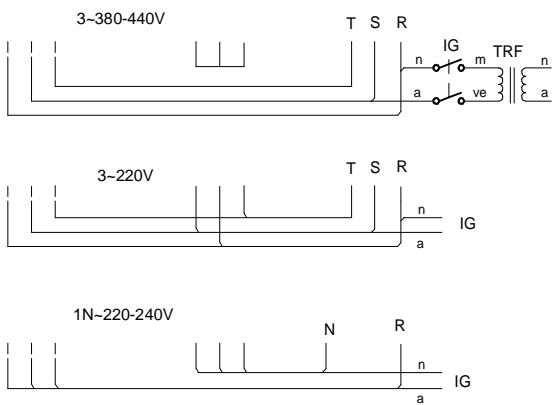

- | | | | |
|--------------------------------|-----------------------------|--------------------------|----------------------|
| C1,C2: Contactor calentamiento | C1,C2: Contacteur chauffage | C1,C2: Heating relay | C1,C2: Heating relay |
| IB: Micro tope bajada | IB: Micro bride desceinte | IB: Descént tops witch | IB: M |
| IG: Interruptor general | IG: Interrupteur général | IG: Main switch | IG: H |
| IMB: Pulsador bajada | IMB: Commande de baisse | IMB: Descent switch | IMB: M |
| IMS: Pulsador subida | IMS: Commande de montée | IMS: Elevation switch | IMS: M |
| IP: Micro seguridad | Ip: Micro sécurité | IP: Security switch | IP: M |
| IS: Micro tope subida | Is: Micro bride montée | IS: Elevating top switch | IS: M |
| L1: Lampara marcha | L1: Veilleuse mise en route | L1: On light | L1: F |
| L2: Lampara calentamiento | L2: Veilleuse chauffage | L2: Heating light | L2: E |
| M: Motor | M: Moteur | M: Motor | M: M |
| PR: Puente rectificador | PR: Pont rectificateur | PR: Rectifier bridge | PR: H |
| R: Resistencia calentamiento | R: Résistance chauffage | R: Heating element | R: H |
| T: Termostato | T: Thermostat | T: Thermostat | T: T |
| TRF: Transformador | TRF: Transformateur | TRF: Transformer | TRF: T |
| TS: Termostato seguridad | TS: Thermostat sécurité | TS: Security thermostat | TS: T |

Esquema teórico SBEM		
Nº	Pieza	
Nº	Modificacion	
Firma		Fecha
Dibujado KONTXI		9/5/2001
Proyectado		
Comprobado		
Escala		
SARTE		
Plano hau ez datéke erabil ez berizta gure b		

Зип Общежит

vsezip.ru

+7(812)987-08-81

Calzar con una arandela

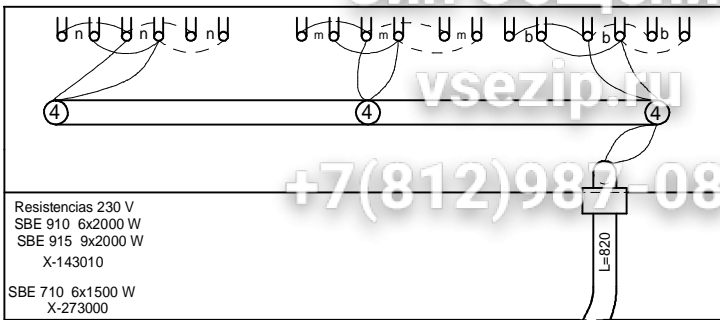
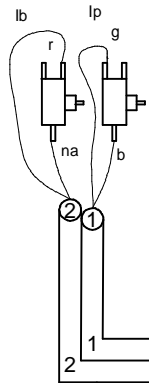

Resistencias 230 V
SBE 910 6x2000 W
SBE 915 9x2000 W
X-143010
SBE 710 6x1500 W
X-273000

Instalación	SBE x10	SBE 915
1	X-143015	
2	X-283000	
3	X-143016	X-423005
4	X-143004	X-423004

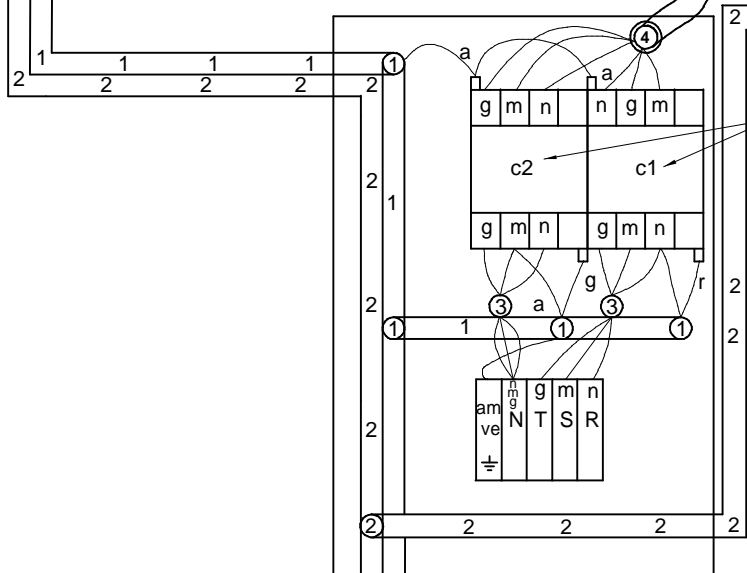

SBE X10 R-663031
SBE 915 X-183011

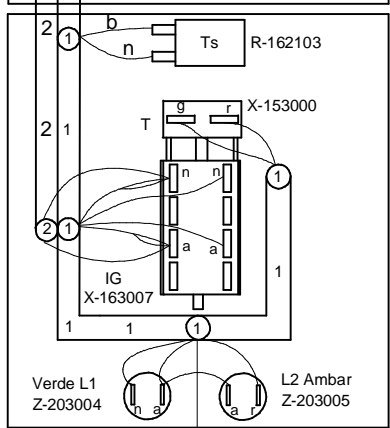
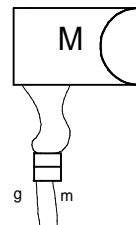
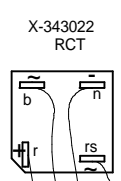
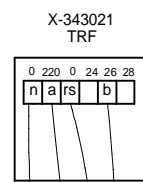

Esquema de montaje electrico		
Nº	Pieza	
Nº	Modificacion	
	Firma	Fecha
Dibujado	KONTXI	18/01/2002
Proyectado		
Comprobado		
Escala		
SARTEN		
Plano hau ez dateke erabil ez berizta gure b		