

Зип Общепит

vsezip.ru

+7(812)987-08-81

DESPIECES

MESAS MFP-CAJONES

GASTRONORM



Rev.: Feb-2011

Зип Общепит

RECAMBIOS
MESAS
MFP-CAJONES
FEB-2011



MODELOS

Nº	CÓDIGO	DESCRIPCIÓN	MODELOS															
			MFP-135-2C/GN	MFP-135-4C/GN	MFP-180-2C/GN	MFP-180-4C/GN	MFP-180-6C/GN	MFP-225-2C/GN	MFP-225-4C/GN	MFP-270-2C/GN	MFP-270-4C/GN	MFP-270-6C/GN	MFP-270-8C/GN	MFP-270-10C/GN	MFP-270-12C/GN	MFP-270-14C/GN	MFP-270-16C/GN	
1	6003010326	DESAG COMPL 3/4 GRIS+TUERCA	1	1	1	1	1	1	1	1	1	1	1	1	1	1	1	
2	6003010262	TAPON DESAGÜE DE 3/4 CIEGO	1	1	1	1	1	1	1	1	1	1	1	1	1	1	1	
3	6003010327	JUNTA GOMA DESAGÜE 3/4	1	1	1	1	1	1	1	1	1	1	1	1	1	1	1	
4	M181010460	ENCIM.MFP-135 C/PETO	1	1														
4	M181010366	ENCIM.MFP-180 C/PETO			1	1	1											
4	M181010462	ENCIM.MFP-225 C/PETO					1	1	1	1								
4	M181010481	ENCIM.MFP-270 C/PETO							1	1	1	1	1					
4	M181010466	ENCIM.MFP-102-R C/PETO											1	1				
4	M181010469	ENCIM.MFP-147-R C/PETO												1	1	1		
4	M181010479	ENCIM.MFP-192-R C/PETO													1	1	1	
4	M181010521	ENCIM.MFP-237-R C/PETO														1	1	
5	M109170851	PROTECT.TRASER.MFP-135	1	1														
5	M109170852	PROT.TRAS.ENC.MFP-180			1	1	1	1	1	1	1	1	1	1			1	
5	M109170855	PROT.TRAS.ENC.MFP-102												1	1			
5	M109170856	PROT.TRAS.ENC.MFP-147													1	1	1	
5	M109170857	PROT.TRAS.ENC.MFP-192														1	1	
6	6033090086	JUEGO TAPETAS ENCIM.ZAMAK	1	1	1	1	1	1	1	1	1	1	1	1	1	1	1	
7	M109170853	PROT.TRAS.ENC.MFP-225-237 SUPL					1	1	1	1						1	1	
7	M109170854	PROT.TRAS.ENC.MFP-270 SUPL							1	1	1	1	1					
9	6007050017	PATA REGULAB ARM GASTRO	4	4	4	4	4	6	6	6	6	6	6	4	4	4	4	
10	M169010093	PUERTA MFP/MFN FAGOR	1		2	1		3	2	1		4	3	2	1		2	
11	6045010119	BURLETE MFP 399X585	1		2	1		3	2	1		4	3	2	1		2	
12	6003010136	CAJA ALOJAMIENTO MUELLE GRIS	1		2	1		3	2	1		4	3	2	1		2	
13	6033010100	BIS.TRS1D DOBL MUELLE DV-2608	1		2	1		3	2	1		4	3	2	1		2	
14	6033010129	SOP.BISAG.INF.IZD.	1		2	1		3	2	1		4	3	2	1		2	
15	6033090104	EJE ROSCA EXT.30X10INOX MESAS	1		2	1		3	2	1		4	3	2	1		2	
16	6025130045	TUERCA.RAPIDA TRT M6-2	2	1	3	2	1	4	3	2	1	5	4	3	2	1	3	
17	M109050552	SOPOR.SUP.PUERTAS MFP-135	1	1														
17	M109050242	SOP.SUP.PUERTAS MFP-180			1	1	1											
17	M109050555	SOP.SUP.PUERT. MFP-225						1	1	1	1							
17	M109050565	SOP.SUP.PUERTAS MFP-270							1	1	1	1	1					
17	M109050557	SOP.SUP.PUERT.MFP-102-R												1	1			
17	M109050560	SOP.SUP.PUERT.MFP-147-R													1	1	1	
17	M109050562	SOP.SUP.PUERT.MFP-192-R														1	1	
17	M109050596	SOP.SUPER.PUERTAS MFP-237-R															1	
20	M177010065	CHAP.CUAD.MANDOS	1	1	1	1	1	1	1	1	1	1	1	1	1			
20	M109010642	CUADRO MANDOS MSP-R												1	1	1	1	
21	M109050532	PROTECC.INST.ELECT.FAGOR	1	1	1	1	1	1	1	1	1	1	1	1	1	1	1	
22	6033090090	SOPORTE ZAMAK GIRO REJILLA	1	1	1	1	1	1	1	1	1	1	1	1	1	1	1	
23	6033090104	EJE ROSCA EXT.30X10INOX MESAS	1	1	1	1	1	1	1	1	1	1	1	1	1	1	1	
24	6023010408	PEG.CUAD.FAGOR REFR.347,5X60	1	1	1	1	1	1	1	1	1	1	1	1	1	1	1	
24	6023010418	PEG.105X220 CUADR.REMOT FAGOR													1	1	1	
25	6021130001	INT.BIP.AMB.O/I CONTAC.REFORZ.	1	1	1	1	1	1	1	1	1	1	1	1	1	1	1	
26	6021350018	TERMOS REFRI CAREL PYCO1RN515	1	1	1	1	1	1	1	1	1	1	1	1	1	1	1	
27	6021130010	PILOTO RECTAN.AMBAR LUM.FAGOR												1	1	1	1	
30	6021010004	COMPR.FR-7,5-G R134A	1	1														
30	6021010007	COMPR.FR-8,5-G R134A			1	1	1											
30	6021010154	COMP.NEK6210Z EMBRACO					1	1	1	1	1	1	1	1	1	1	1	
31	6029020002	CONDENSADOR 9x2	1	1	1	1	1											
31	6029020003	CONDENSADOR 9x3 FAGC0021					1	1	1	1	1	1	1	1	1	1	1	
32	6021050002	VENTILADOR 10W PATA PALA 220V	1	1	1	1	1	1	1	1	1	1	1	1	1	1	1	
33	6021310003	VALVULA OBUS COMPLETA RF.HB-1S	1	1	1	1	1	1	1	1	1	1	1	1	1	1	1	
34	6047010003	FILTRO DESHIDRAT.40GR 1/4X1/4	1	1	1	1	1	1	1	1	1	1	1	1	1	1	1	
35	M107010037	SERP.EV.AUTOM.1/4 PINT.150,200	1	1	1	1	1	1	1	1	1	1	1	1	1	1	1	
36	6003010023	BANDEJA EVAPORACION AUTOMÁTICA	1	1	1	1	1	1	1	1	1	1	1	1	1	1	1	
37	M109250127	OMEGA COND.9X2-REJ.MESAS-ARMAR	1	1	1	1	1	1	1	1	1	1	1	1	1	1	1	
40	M171010108	UD.EV.MSP150,200,135,180 COMP.	1	1	1	1	1											
40	M171010109	UD.EV. MSP250,300,225,270 COMP					1	1	1	1	1	1	1	1	1	1	1	
40	M171010113	UD.EV. MSP-117,102,169-R COMP.												1	1	1	1	
40	M171010116	EV.MSP-222,274														1	1	
41	6029010151	BAT.5T4R300A4S PINT.MESAS	1	1	1	1	1								1	1	1	
41	6029010150	BAT 6T4R300A4S PINT.MESAS					1	1	1	1	1	1	1	1	1	1	1	
42	M109250148	SUJ.VENTIL.MSP-150,200 COMPACT	1	1	1	1	1	1	1	1	1	1	1	1	1	1	1	
43	6027130004	REJILLA VENT.D.246 PINTADA	1	1	1	1	1	1	1	1	1	1	1	1	1	1	1	
44	6021050066	VENTIL.EVAPOR.SW S/ARO S/PATAS	1	1	1	1	1	1	1	1	1	1	1	1	1	1	1	
45	M109250151	SOP.EVAP.MESAS EVAP.COMPACTO	1	1	1	1	1	1	1	1	1	1	1	1	1	1	1	
46	M109250150	CUBRER.BAT.6T4R300A6S EVAP.COM	1	1	1	1	1	1	1	1	1	1	1	1	1	1	1	
47	6003010184	CANALIZAD.AGUA 150 GRIS REFRIG	1	1	1	1	1	1	1	1	1	1	1	1	1	1	1	
50	6033050015	GUIA SNAK.DT.CONG-MESA GN562mm	4		8	4		12	8	4		16	12	8	4		4	
51	6027010003	PARRIL. GN1/1 530X325	1		2	1		3	2	1		4	3	2	1		2	
54	M109050301	CREMALL.RESP.IZDA.MFP	2	2	3	3	3	4	4	4	4	5	5	5	5	2	2	
55	M109050587	CREM.RESP.DCH.CONG MFN	2	2	2	2	2	2	2	2	2	2	2	2	2	2	2	
56	M109050747	CREM. MARC. MAGNETICO MSP-MFP	4	4	6	6	6	8	8	8	8	10	10	10	10	10	10	

Зип Общежит

RECAMBIOS
MESAS
MFP-CAJONES
FEB-2011



MODELOS

Nº	CÓDIGO	DESCRIPCIÓN	MFP-135-2C/GN	MFP-135-4C/GN	MFP-180-2C/GN	MFP-180-4C/GN	MFP-180-6C/GN	MFP-180-8C/GN	MFP-210-2C/GN	MFP-210-4C/GN	MFP-210-6C/GN	MFP-210-8C/GN	MFP-210-10C/GN	MFP-210-12C/GN	MFP-210-14C/GN	MFP-210-16C/GN	MFP-210-18C/GN	MFP-210-20C/GN	MFP-210-22C/GN	MFP-210-24C/GN	MFP-210-26C/GN	MFP-210-28C/GN	MFP-210-30C/GN	MFP-210-32C/GN	MFP-210-34C/GN	MFP-210-36C/GN	MFP-210-38C/GN	MFP-210-40C/GN	
57	M109050300	CREMALL.RESP.DCHA.MFP	1	1	1	1	1	1	1	1	1	1	1	1	1	1	1	1	1	1	1	1	1	1	1	1	1	1	
60	6003010181	REJ.RESP.GRUPO 387X280POLICARB	1	1	1	1	1	1	1	1	1	1	1	1	1	1	1	1	1	1	1	1	1	1	1	1	1	1	1
61	6021390006	MANG 3X1X2500 BL. SCHUKO 3T	1	1	1	1	1	1	1	1	1	1	1	1	1	1	1	1	1	1	1	1	1	1	1	1	1	1	1
62	M109050033	PROT SONDA 175x49	1	1	1	1	1	1	1	1	1	1	1	1	1	1	1	1	1	1	1	1	1	1	1	1	1	1	1
70	6021010037	CONDEN.ARRANQUE FR-117U5015 80 mF	1	1	1	1	1	1	1	1	1	1	1	1	1	1	1	1	1	1	1	1	1	1	1	1	1	1	1
70	6021010158	CONDENSADOR COMP. NEK 6210Z						1	1	1	1	1	1	1	1	1	1	1	1	1	1	1	1	1	1	1	1	1	1
71	6021010045	RELE ARRANQ COMPR.FR-7.5G 6001	1	1																									
71	6021010025	RELE ARRANQUE COMPRESOR FR-8,5G 2			1	1	1																						
71	6021010156	RELE ARRAN. COMP. NEK 6210Z						1	1	1	1	1	1	1	1	1	1	1	1	1	1	1	1	1	1	1	1	1	1
90	M169120117	CAJÓN MFP 1/2	2	3	2	4	5	2	4	6	7	2	4	6	8	9	2	3	2	4	5	2	4	6	7	2	6	8	8
91	M109050101	CAJON GASTRO 1º CASO 190 prof.	2	3	2	4	5	2	4	6	7	2	4	6	8	9	2	3	2	4	5	2	4	6	7	2	6	8	8
92	M169120118	FRENTE CAJÓN MFP 1/2	2	4	2	4	6	2	4	6	8	2	4	6	8	10	2	4	2	4	6	2	4	6	8	2	6	8	8
93	6045010122	BURLET CAJ 1/2 MFP 399X274	2	4	2	4	6	2	4	6	8	2	4	6	8	10	2	4	2	4	6	2	4	6	8	2	6	8	8
94	6033050006	GUIA DE ACERO L550 BRILLO(JUEGO)	2	4	2	4	6	2	4	6	8	2	4	6	8	10	2	4	2	4	6	2	4	6	8	2	6	8	8
95	M169120119	CAJÓN MFP 1/2LAD.GRUPO		1			1				1					1			1					1					
96	M109050102	CAJON GASTRO 2º CASO 100 prof.		1			1				1					1			1				1						
100	M161130006	FRONTI POSTIZO MFP CAJ MAGNETI	1	2	1	2	3	1	2	3	4	1	2	3	4	5	1	2	1	2	3	1	2	3	4	1	3	4	4

Зип Общепит

ysezi.ru

+7(812)987-00-81

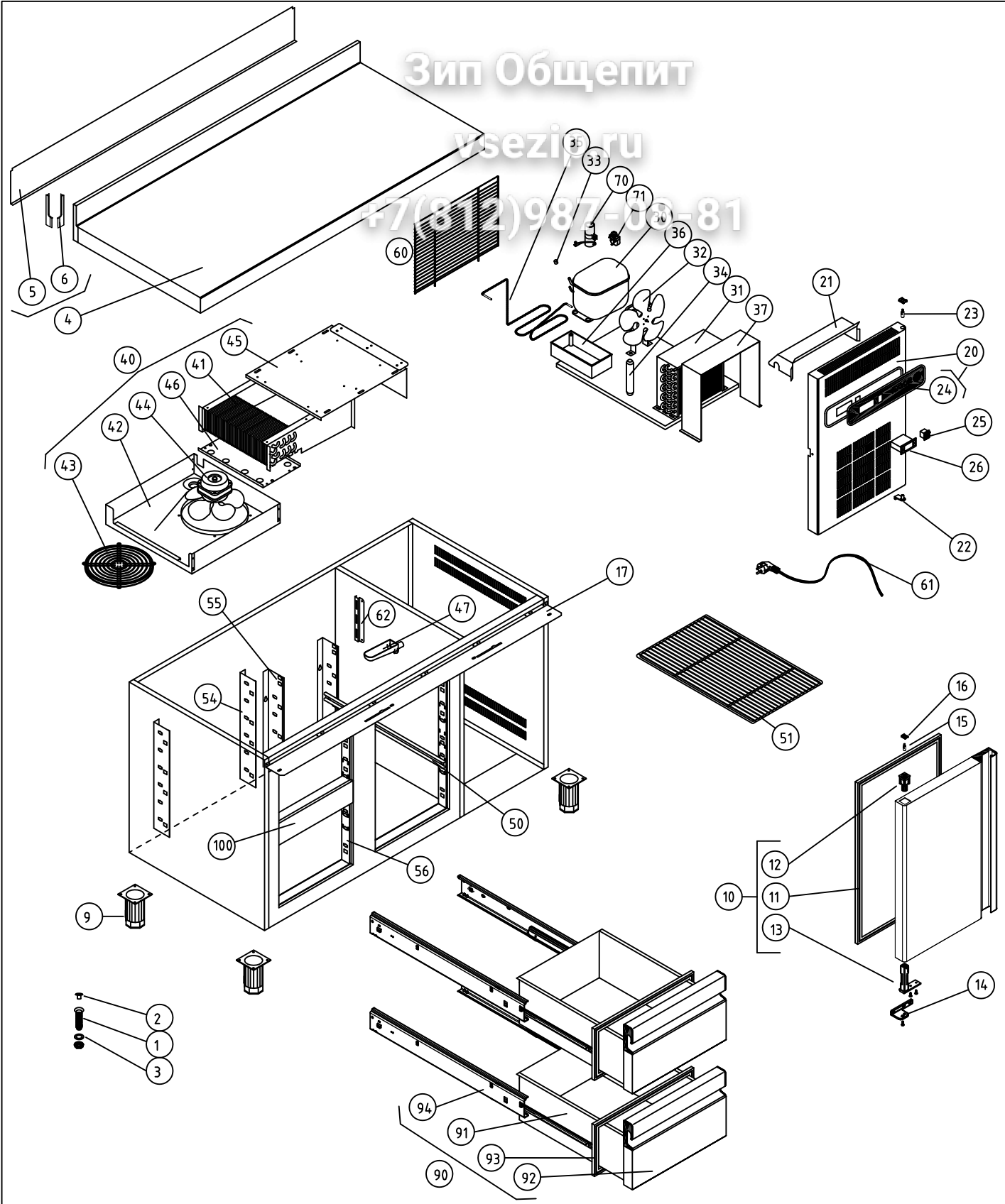



M1 MESAS FRÍAS						COD. PIEZA: 148311020000						
COTAS SIN TOLERANCIA DIN 7168-f						Material: .						
ANGULAR	GRADO TOLERANCIA	FINO	MEDIO	GRUESO	COMUN A	Acabado: .		SUSTITUYE A:				
	HASTA 10 mm		±1°	±1° 30'		SUSTITUIDO POR:						
	MAS DE 10 A 50 mm		±30'	±50'		MODELO	Ud.	MODELO	Ud.	MODELO	Ud.	MODELO
	MAS DE 50 A 120 mm		±20'	±25'		MFP-135-2C	1					
	MAS DE 120 A 400 mm		±10'	±15'								
MAS DE 400 mm		±5'	±10'									
LINEAL	GRADO TOLERANCIA	FINO	MEDIO	GRUESO	A4		Nombre		Fecha		 F A G O F R I	
	HASTA 3 mm		±0,05	±0,10	±0,15	Dibujado		A.J.GONZALEZ		Feb-2011		
	MAS DE 3 A 6 mm		±0,05	±0,10	±0,20	Modificado						
	MAS DE 6 A 30 mm		±0,10	±0,20	±0,50	Escala		1:22		RECAMBIOS MFP-135-2C/GN		
	MAS DE 30 A 120 mm		±0,15	±0,30	±0,80					Código máquina:		
MAS DE 120 A 400 mm		±0,20	±0,50	±1,20								
MAS DE 400 A 1000 mm		±0,30	±0,80	±2,00								
MAS DE 1000 A 2000 mm		±0,50	±1,20	±3,00								

Зип Общепит

ysezi.ru

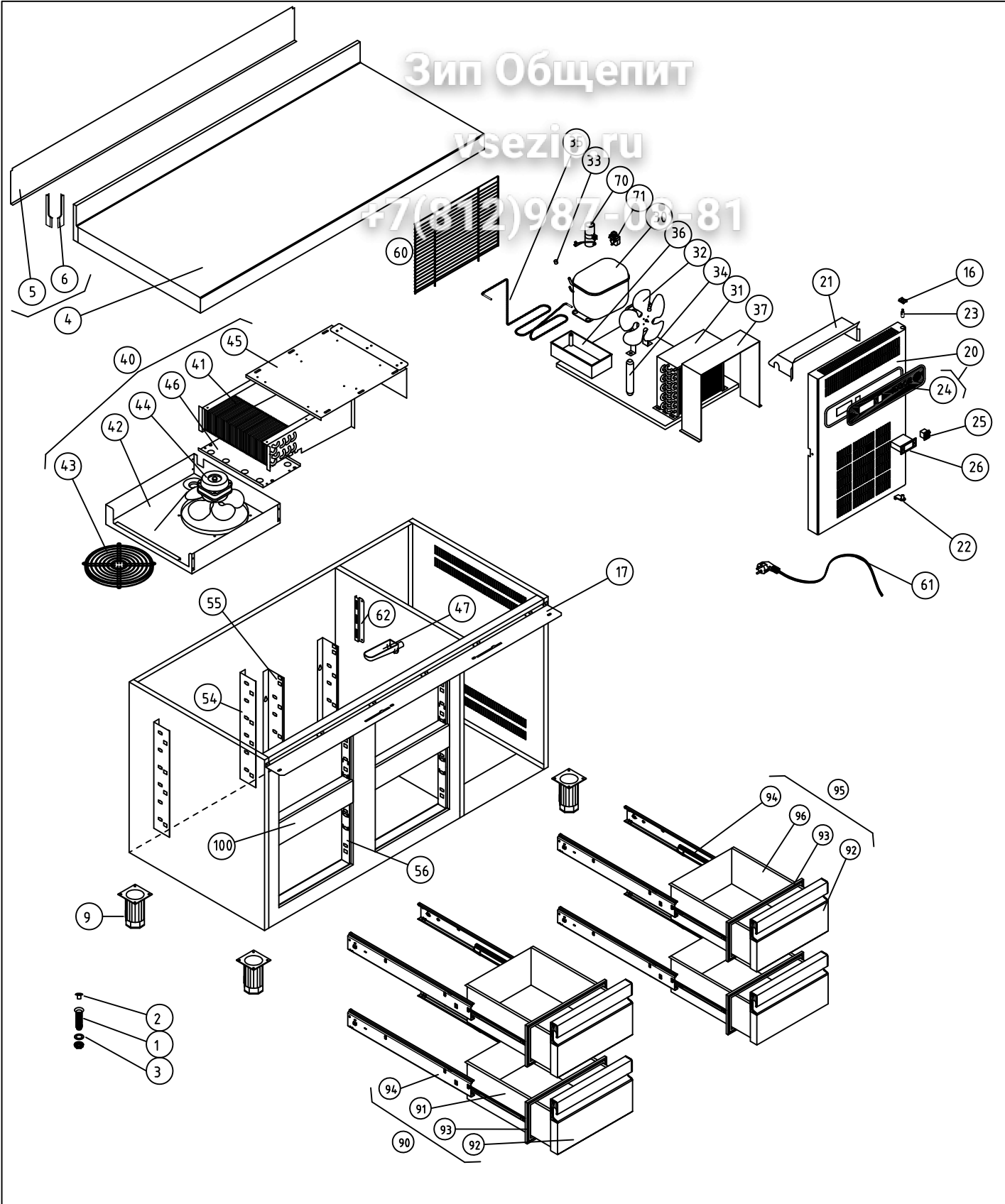
+7(812)987-00-81





M1 MESAS FRÍAS						COD. PIEZA: 148311040000						
COTAS SIN TOLERANCIA DIN 7168-f						Material: .						
ANGULAR	GRADO TOLERANCIA	FINO	MEDIO	GRUESO	COMUN A	Acabado: .		SUSTITUYE A:				
	HASTA 10 mm		±1°	±1° 30'		SUSTITUIDO POR:						
	MAS DE 10 A 50 mm		±30'	±50'		MODELO	Ud.	MODELO	Ud.	MODELO	Ud.	MODELO
	MAS DE 50 A 120 mm		±20'	±25'		MFP-135-4C	1					
	MAS DE 120 A 400 mm		±10'	±15'								
MAS DE 400 mm		±5'	±10'									
LINEAL	GRADO TOLERANCIA	FINO	MEDIO	GRUESO	A4		Nombre		Fecha		 F A G O F R I	
	HASTA 3 mm		±0,05	±0,10	±0,15	Dibujado		A.J.GONZALEZ		Feb-2011		
	MAS DE 3 A 6 mm		±0,05	±0,10	±0,20	Modificado						
	MAS DE 6 A 30 mm		±0,10	±0,20	±0,50	Escala		1:22		RECAMBIOS MFP-135-4C/GN		
	MAS DE 30 A 120 mm		±0,15	±0,30	±0,80					Código máquina:		
MAS DE 120 A 400 mm		±0,20	±0,50	±1,20								
MAS DE 400 A 1000 mm		±0,30	±0,80	±2,00								
MAS DE 1000 A 2000 mm		±0,50	±1,20	±3,00								

Зип Общепит

vsezip.ru

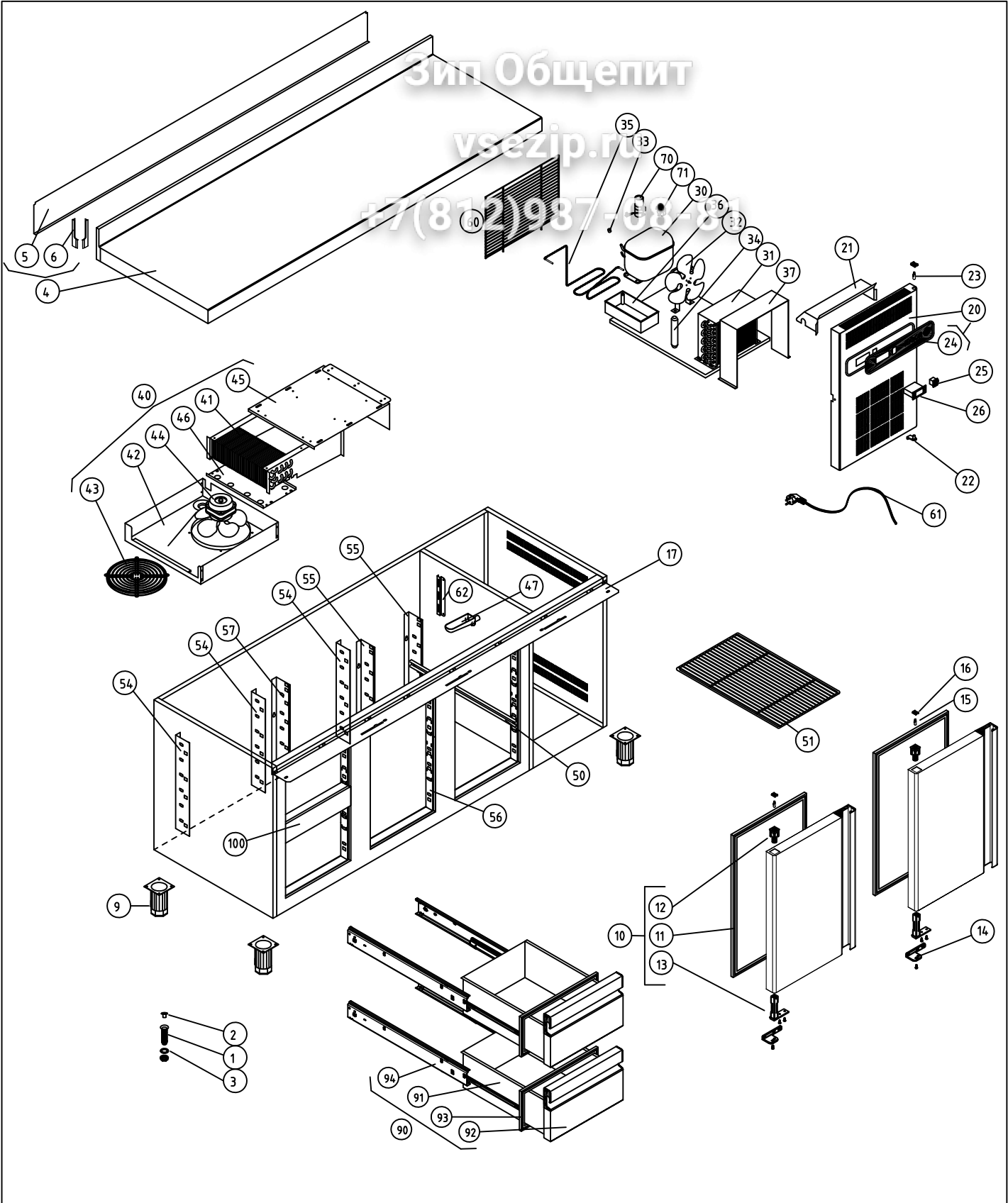
+7(812)987-68-88



M1 MESAS FRIAS				COD. PIEZA: 148312020000							
COTAS SIN TOLERANCIA DIN 7168-f				Material: .							
ANGULAR	GRADO TOLERANCIA	FINO	MEDIO	GRUESO	Acabado: .			SUSTITUYE A:			
	HASTA 10 mm		±1°	±1° 30'	SUSTITUIDO POR:						
	MAS DE 10 A 50 mm		±30'	±50'	MODELO	Ud.	MODELO	Ud.	MODELO	Ud.	MODELO
	MAS DE 50 A 120 mm		±20'	±25'	MFP-180-2C	1					
	MAS DE 120 A 400 mm		±10'	±15'							
MAS DE 400 mm		±5'	±10'								
LINEAL	GRADO TOLERANCIA	FINO	MEDIO	GRUESO	COMUN A						
	HASTA 3 mm		±0,05	±0,10	A4	Nombre		Fecha		FAGOR 	
	MAS DE 3 A 6 mm		±0,05	±0,10	Dibujado	A.J.GONZALEZ		Feb-2011		F A G O R F R I	
	MAS DE 6 A 30 mm		±0,10	±0,20	Modificado					Código máquina:	
	MAS DE 30 A 120 mm		±0,15	±0,30	Escala	1:25		RECAAMBIOS MFP-180-2C/GN			
MAS DE 120 A 400 mm		±0,20	±0,50								
MAS DE 400 A 1000 mm		±0,30	±0,80								
MAS DE 1000 A 2000 mm		±0,50	±1,20								

Зип Общепит

vsezip.ru

+7(812)987-68-88

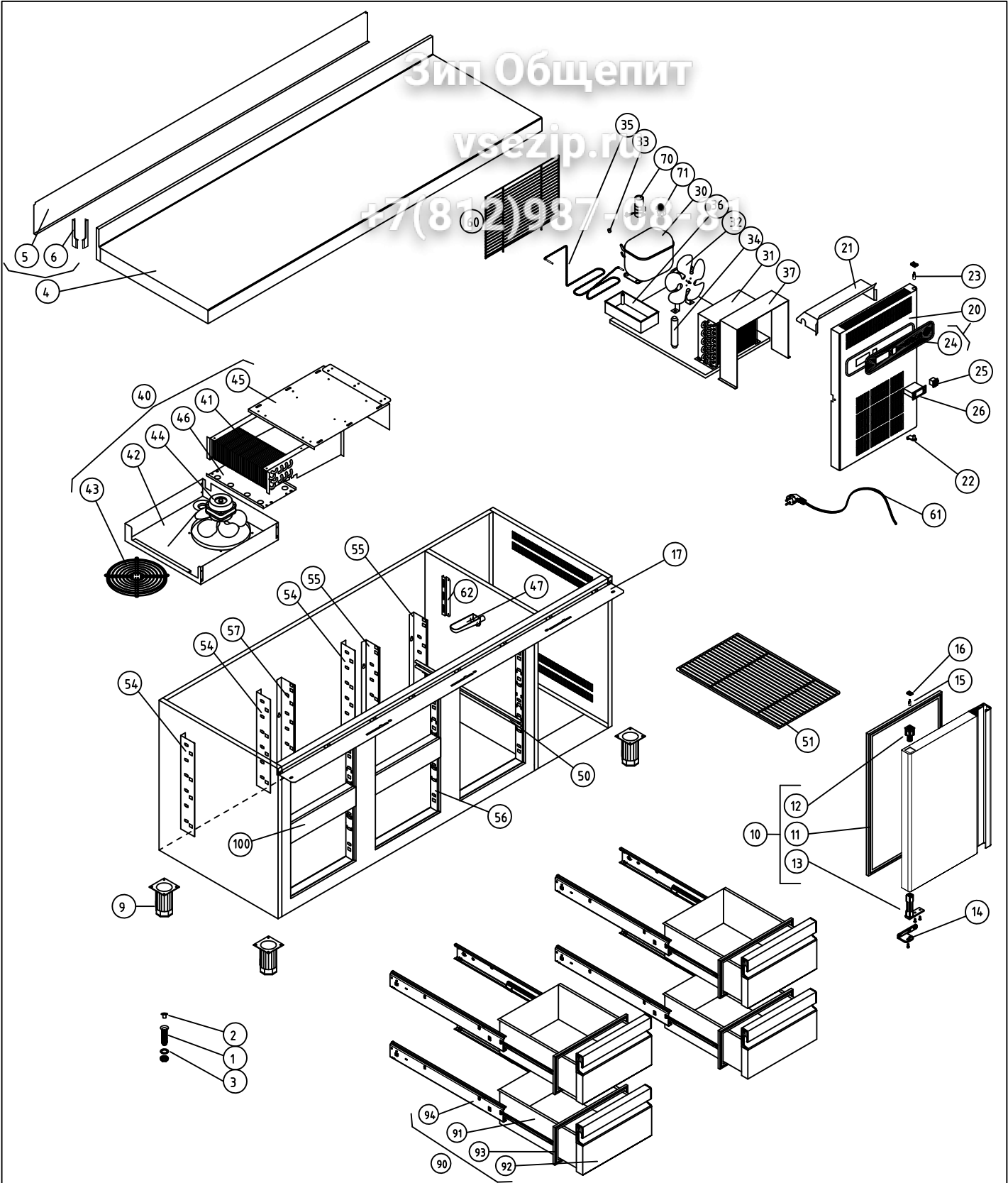



M1 MESAS FRIAS				COD. PIEZA: 148312040000							
COTAS SIN TOLERANCIA DIN 7168-f				Material: .							
ANGULAR	GRADO TOLERANCIA	FINO	MEDIO	GRUESO	Acabado: .			SUSTITUYE A:			
	HASTA 10 mm		±1°	±1° 30'	SUSTITUIDO POR:						
	MAS DE 10 A 50 mm		±30'	±50'	MODELO	Ud.	MODELO	Ud.	MODELO	Ud.	MODELO
	MAS DE 50 A 120 mm		±20'	±25'	MFP-180-4C	1					
LINEAL	MAS DE 120 A 400 mm		±10'	±15'	Nombre			Fecha			
	MAS DE 400 mm		±5'	±10'	A4			Feb-2011			
	GRADO TOLERANCIA	FINO	MEDIO	GRUESO	Dibujado			A.J.GONZALEZ			
	HASTA 3 mm	±0,05	±0,10	±0,15	Modificado						
	MAS DE 3 A 6 mm	±0,05	±0,10	±0,20	Escala			1:25			
MAS DE 6 A 30 mm	±0,10	±0,20	±0,50	RECAAMBIOS MFP-180-4C/GN			Código máquina:				
MAS DE 30 A 120 mm	±0,15	±0,30	±0,80	FAGOR			F A G O F R I				
MAS DE 120 A 400 mm	±0,20	±0,50	±1,20	FAGOR							
MAS DE 400 A 1000 mm	±0,30	±0,80	±2,00								
MAS DE 1000 A 2000 mm	±0,50	±1,20	±3,00								

Зип Общепит

vsezip.ru

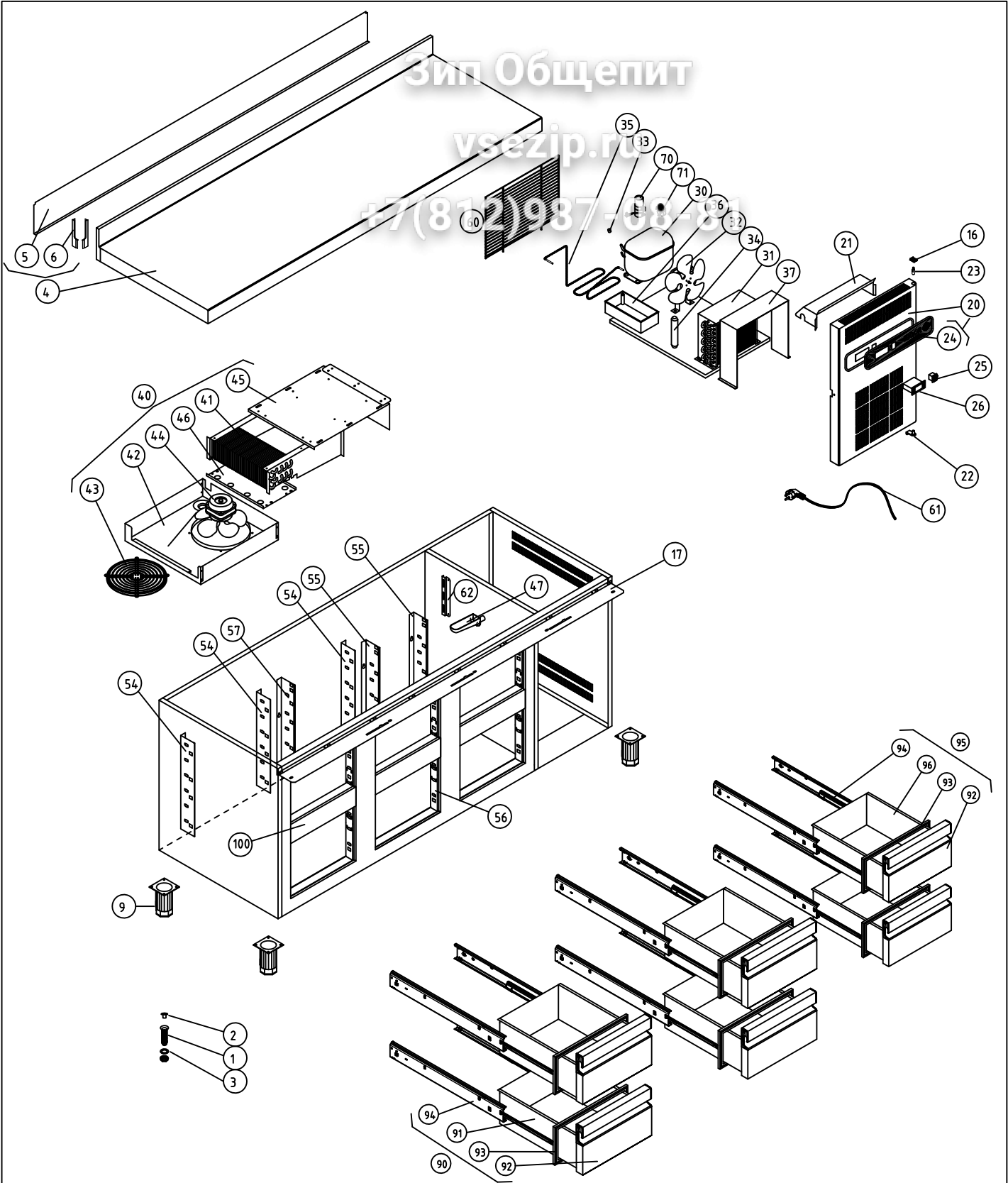
+7(812)987-68-80



M1 MESAS FRIAS						COD. PIEZA: 148312060000						
COTAS SIN TOLERANCIA DIN 7168-f						Material: .						
ANGULAR	GRADO TOLERANCIA	FINO	MEDIO	GRUESO	Acabado: .							
	HASTA 10 mm		±1°	±1° 30'	SUSTITUYE A:							
	MAS DE 10 A 50 mm		±30'	±50'	SUSTITUIDO POR:							
	MAS DE 50 A 120 mm		±20'	±25'	MODELO	Ud.	MODELO	Ud.	MODELO	Ud.	MODELO	Ud.
	MAS DE 120 A 400 mm		±10'	±15'	MFP-180-6C	1						
MAS DE 400 mm		±5'	±10'									
LINEAL	GRADO TOLERANCIA	FINO	MEDIO	GRUESO	A4		Nombre		Fecha		 F A G O R I	
	HASTA 3 mm	±0,05	±0,10	±0,15	Dibujado		A.J.GONZALEZ		Feb-2011			
	MAS DE 3 A 6 mm	±0,05	±0,10	±0,20	Modificado							
	MAS DE 6 A 30 mm	±0,10	±0,20	±0,50	Escala						Código máquina:	
	MAS DE 30 A 120 mm	±0,15	±0,30	±0,80								
	MAS DE 120 A 400 mm	±0,20	±0,50	±1,20								
MAS DE 400 A 1000 mm	±0,30	±0,80	±2,00									
MAS DE 1000 A 2000 mm	±0,50	±1,20	±3,00									
						RECAAMBIOS MFP-180-6C/GN						

Зип-Общепит

vsezip.ru

+7(812)987-08-81

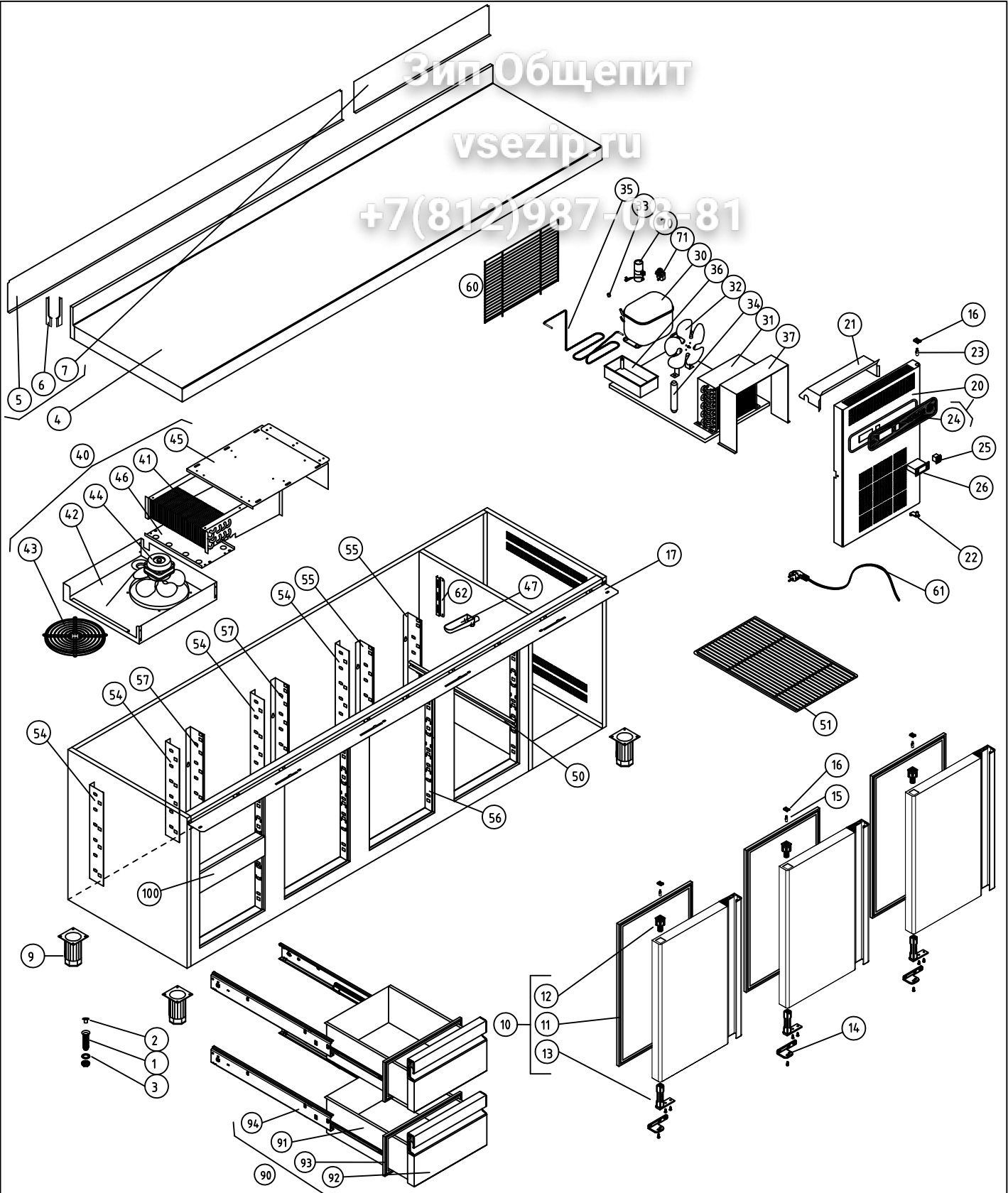

M1 MESAS FRIAS COD. PIEZA: 148313020000

COTAS SIN TOLERANCIA DIN 7168-f Material: .

ANGULAR

GRADO TOLERANCIA	FINO	MEDIO	GRUESO
HASTA 10 mm		±1°	±1° 30'
MAS DE 10 A 50 mm		±30'	±50'
MAS DE 50 A 120 mm		±20'	±25'
MAS DE 120 A 400 mm		±10'	±15'
MAS DE 400 mm		±5'	±10'

Acabado: .

ANGULAR	COMUN A		COMUN A		COMUN A		COMUN A	
	MODELO	Ud.	MODELO	Ud.	MODELO	Ud.	MODELO	Ud.
	MFP-225-2C	1						

LINEAL	COMUN A		COMUN A		COMUN A		COMUN A	
	MODELO	Ud.	MODELO	Ud.	MODELO	Ud.	MODELO	Ud.

GRADO TOLERANCIA	FINO	MEDIO	GRUESO	A4	Nombre	Fecha	FAGOR F A G O F R I
HASTA 3 mm	±0,05	±0,10	±0,15	Dibujado	A.J.GONZALEZ	Feb-2011	
MAS DE 3 A 6 mm	±0,05	±0,10	±0,20	Modificado			
MAS DE 6 A 30 mm	±0,10	±0,20	±0,50	Escala	1:25		RECAAMBIOS MFP-225-2C/GN
MAS DE 30 A 120 mm	±0,15	±0,30	±0,80				Código máquina:
MAS DE 120 A 400 mm	±0,20	±0,50	±1,20				
MAS DE 400 A 1000 mm	±0,30	±0,80	±2,00				
MAS DE 1000 A 2000 mm	±0,50	±1,20	±3,00				

Зип-Общепит

vsezip.ru

+7(812)987-08-81

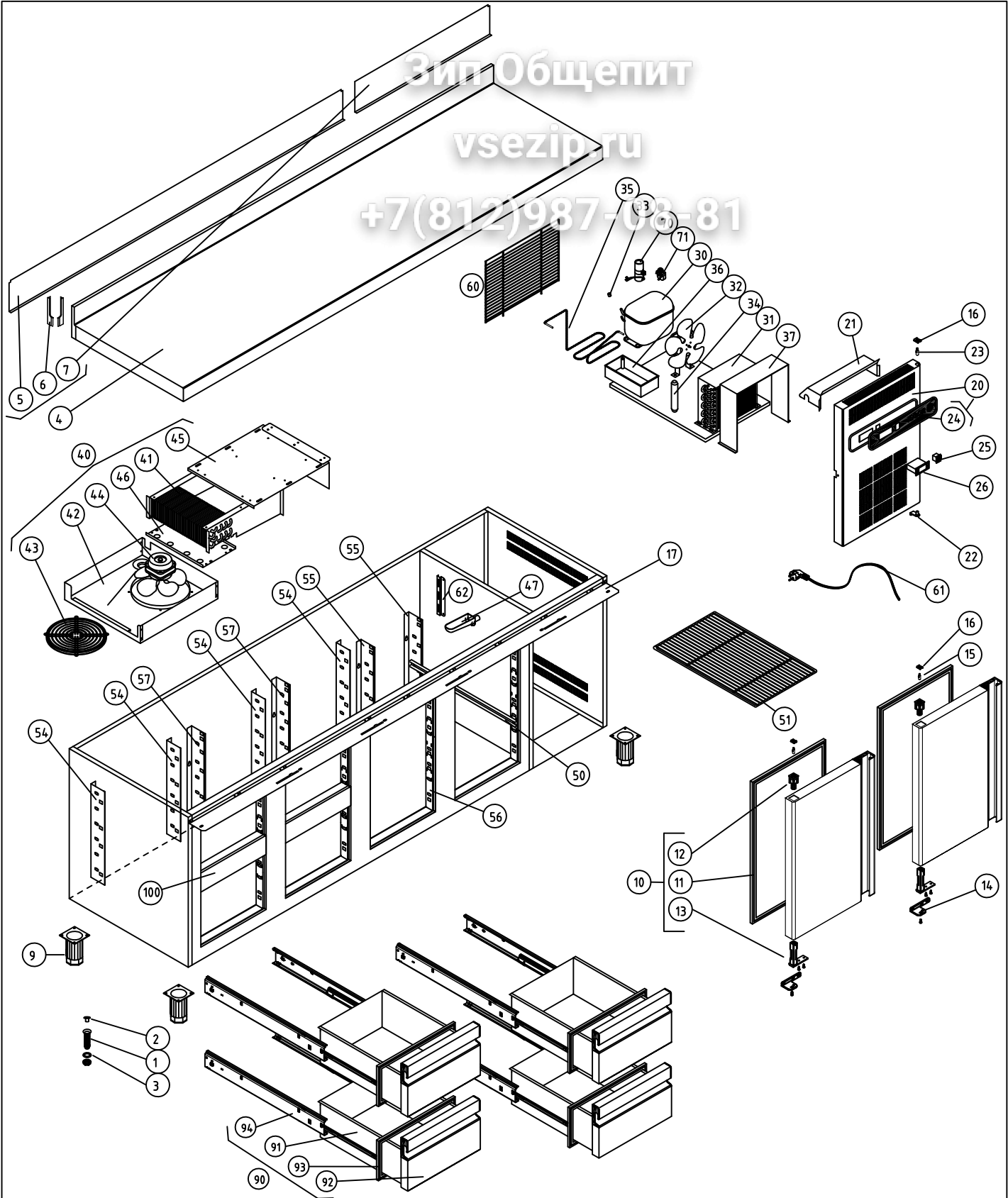



M1 MESAS FRIAS						COD. PIEZA: 148313040000										
COTAS SIN TOLERANCIA DIN 7168-f						Material: .										
SUSTITUYE A:						SUSTITUIDO POR:										
ANGULAR	GRADO TOLERANCIA	FINO	MEDIO	GRUESO	COMUN A	MODELO	Ud.	MODELO	Ud.	MODELO	Ud.	MODELO	Ud.	MODELO	Ud.	
	HASTA 10 mm		±1°	±1° 30'		MFP-225-4C	1									
	MAS DE 10 A 50 mm		±30'	±50'												
	MAS DE 50 A 120 mm		±20'	±25'												
LINEAL	MAS DE 120 A 400 mm		±10'	±15'	A4	Nombre		Fecha		 F A G O R I						
	MAS DE 400 mm		±5'	±10'		A.J.GONZALEZ		Feb-2011								
	GRADO TOLERANCIA	FINO	MEDIO	GRUESO		Dibujado		Modificado								
	HASTA 3 mm		±0,05	±0,10		±0,15	Escala		RECAAMBIOS MFP-225-4C/GN							
	MAS DE 3 A 6 mm		±0,05	±0,10		±0,20	Código máquina:									
MAS DE 6 A 30 mm		±0,10	±0,20	±0,50												
MAS DE 30 A 120 mm		±0,15	±0,30	±0,80												
MAS DE 120 A 400 mm		±0,20	±0,50	±1,20												
MAS DE 400 A 1000 mm		±0,30	±0,80	±2,00												
MAS DE 1000 A 2000 mm		±0,50	±1,20	±3,00												

Зип-Общепит

vsezip.ru

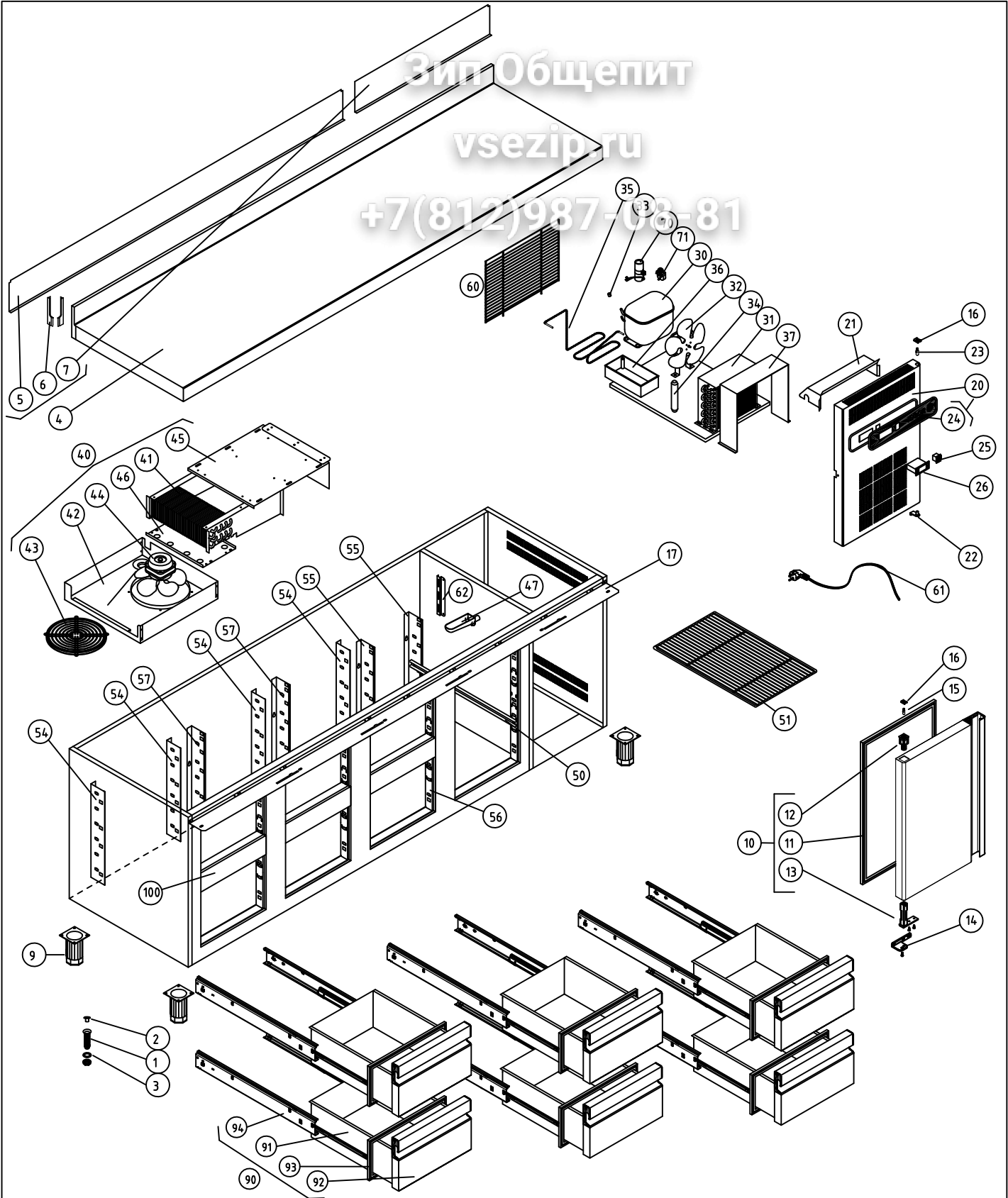
+7(812)987-08-81



M1 MESAS FRIAS						COD. PIEZA: 148313060000								
COTAS SIN TOLERANCIA DIN 7168-f						Material: .								
Material: .						SUSTITUYE A:								
Acabado: .						SUSTITUIDO POR:								
ANGULAR	GRADO TOLERANCIA	FINO	MEDIO	GRUESO	COMUN A	MODELO	Ud.	MODELO	Ud.	MODELO	Ud.	MODELO	Ud.	MODELO
	HASTA 10 mm		±1°	±1° 30'		MFP-225-6C	1							
	MAS DE 10 A 50 mm		±30'	±50'										
	MAS DE 50 A 120 mm		±20'	±25'										
LINEAL	MAS DE 120 A 400 mm		±10'	±15'										
	MAS DE 400 mm		±5'	±10'										
	GRADO TOLERANCIA	FINO	MEDIO	GRUESO	A4	Nombre	Fecha		 F A G O F R I					
	HASTA 3 mm	±0,05	±0,10	±0,15	Dibujado	A.J.GONZALEZ	Feb-2011							
MAS DE 3 A 6 mm	±0,05	±0,10	±0,20	Modificado										
MAS DE 6 A 30 mm	±0,10	±0,20	±0,50	Escala	RECAAMBIOS MFP-225-6C/GN					Código máquina:				
MAS DE 30 A 120 mm	±0,15	±0,30	±0,80	1:25										
MAS DE 120 A 400 mm	±0,20	±0,50	±1,20											
MAS DE 400 A 1000 mm	±0,30	±0,80	±2,00											
MAS DE 1000 A 2000 mm	±0,50	±1,20	±3,00											

Зип-Общепит

vsezip.ru

+7(812)987-08-81

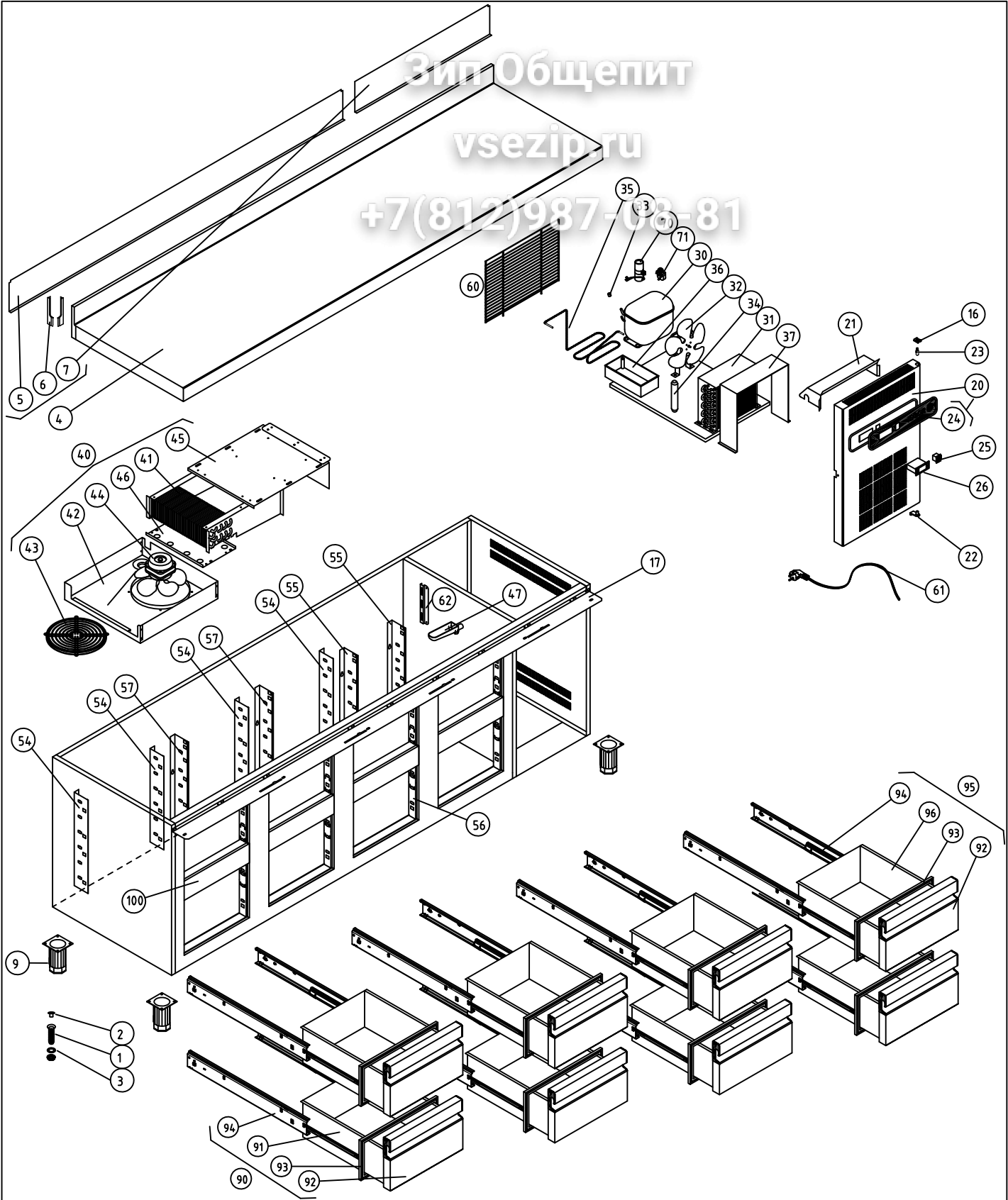

M1 MESAS FRIAS						COD. PIEZA: 148313080000							
COTAS SIN TOLERANCIA DIN 7168-f						Material: .							
ANGULAR	GRADO TOLERANCIA	FINO	MEDIO	GRUESO	COMUN A	Acabado: .				SUSTITUYE A:			
	HASTA 10 mm		±1°	±1° 30'		SUSTITUIDO POR:							
	MAS DE 10 A 50 mm		±30'	±50'		MODELO	Ud.	MODELO	Ud.	MODELO	Ud.	MODELO	Ud.
	MAS DE 50 A 120 mm		±20'	±25'		MFP-225-8C	1						
	MAS DE 120 A 400 mm		±10'	±15'									
MAS DE 400 mm		±5'	±10'										
LINEAL	GRADO TOLERANCIA	FINO	MEDIO	GRUESO	A4		Nombre		Fecha				
	HASTA 3 mm		±0,05	±0,10	±0,15	Dibujado		A.J.GONZALEZ		Feb-2011			
	MAS DE 3 A 6 mm		±0,05	±0,10	±0,20	Modificado							
	MAS DE 6 A 30 mm		±0,10	±0,20	±0,50	Escala		1:25		RECAAMBIOS MFP-225-8C/GN			
	MAS DE 30 A 120 mm		±0,15	±0,30	±0,80					Código máquina:			
	MAS DE 120 A 400 mm		±0,20	±0,50	±1,20								
MAS DE 400 A 1000 mm		±0,30	±0,80	±2,00									
MAS DE 1000 A 2000 mm		±0,50	±1,20	±3,00									



F A G O R I

Вип-Общепит

vsezip.ru

+7(812)987-08-88

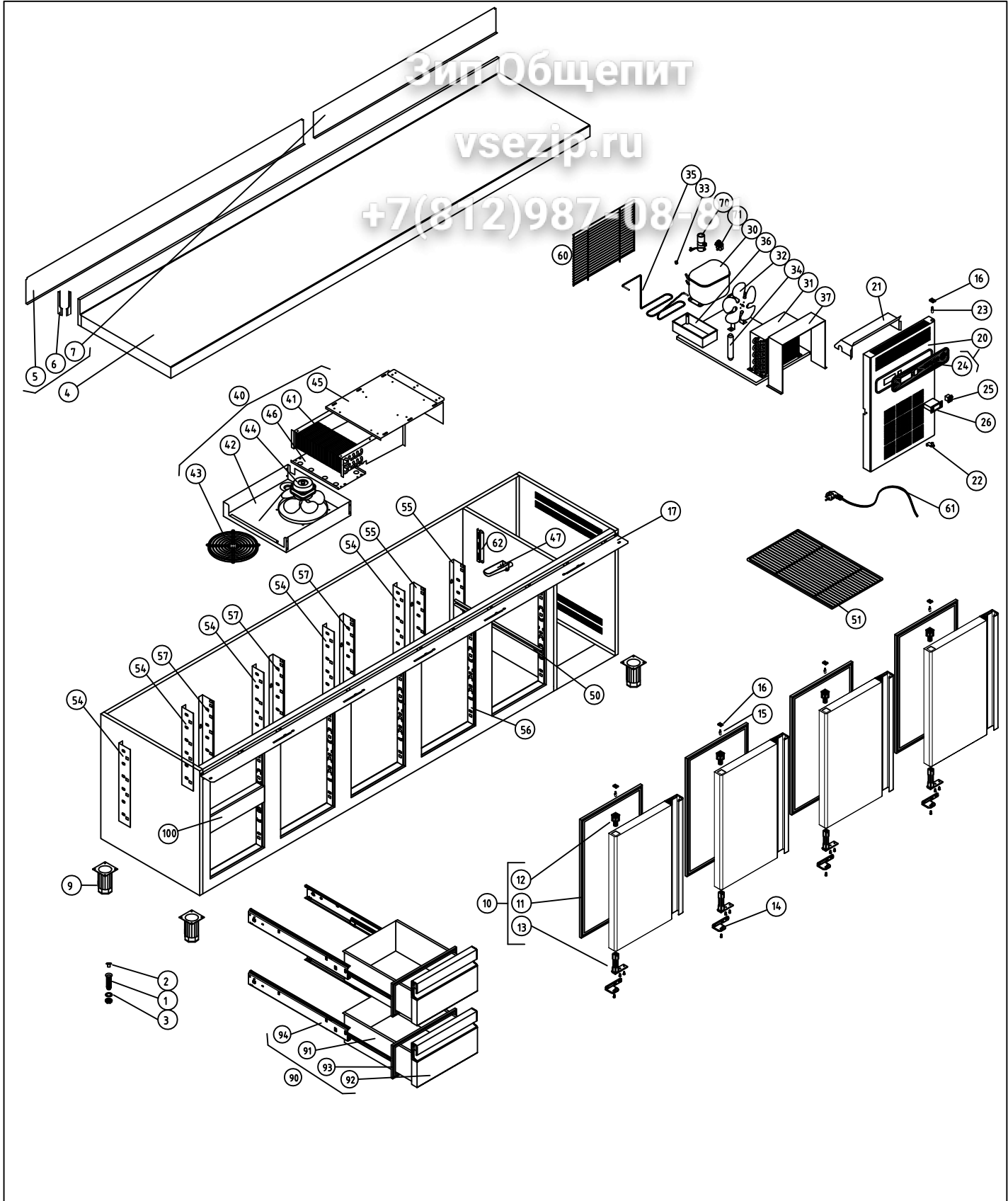

M1 MESAS FRIAS				COD. PIEZA: 148314020000							
COTAS SIN TOLERANCIA DIN 7168-f				Material: .							
ANGULAR	GRADO TOLERANCIA	FINO	MEDIO	GRUESO	Acabado: .			SUSTITUYE A:			
	HASTA 10 mm		±1°	±1° 30'	SUSTITUIDO POR:						
	MAS DE 10 A 50 mm		±30'	±50'	MODELO	Ud.	MODELO	Ud.	MODELO	Ud.	MODELO
	MAS DE 50 A 120 mm		±20'	±25'	MFP-270-2C	1					
	MAS DE 120 A 400 mm		±10'	±15'							
MAS DE 400 mm		±5'	±10'								
LINEAL	GRADO TOLERANCIA	FINO	MEDIO	GRUESO	COMUN A						
	HASTA 3 mm		±0,05	±0,10	±0,15	A4	Nombre	Fecha			
	MAS DE 3 A 6 mm		±0,05	±0,10	±0,20	Dibujado	A.J.GONZALEZ	Feb-2011			
	MAS DE 6 A 30 mm		±0,10	±0,20	±0,50	Modificado					
	MAS DE 30 A 120 mm		±0,15	±0,30	±0,80	Escala					
	MAS DE 120 A 400 mm		±0,20	±0,50	±1,20	1:30	RECAAMBOS MFP-270-2C/GN				
MAS DE 400 A 1000 mm		±0,30	±0,80	±2,00					Código máquina:		
MAS DE 1000 A 2000 mm		±0,50	±1,20	±3,00							



F A G O R I

Вип-Общепит

vsezip.ru

+7(812)987-08-88

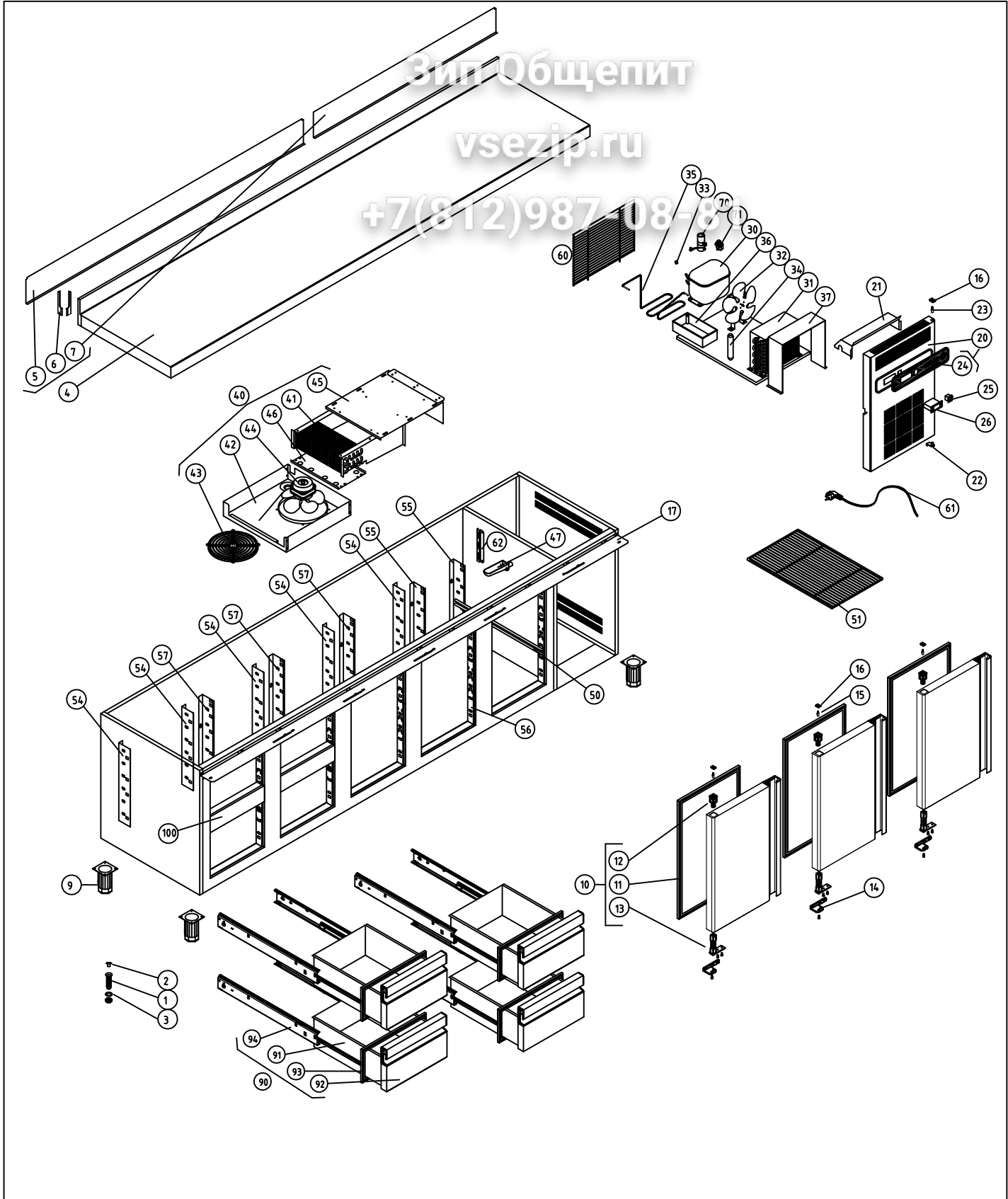

M1 MESAS FRIAS

COD. PIEZA: 148314040000

COTAS SIN TOLERANCIA DIN 7168-f

Material: .

SUSTITUYE A:

Acabado: .

SUSTITUIDO POR:

	GRADO TOLERANCIA	FINO	MEDIO	GRUESO
ANGULAR	HASTA 10 mm		±1°	±1° 30'
	MAS DE 10 A 50 mm		±30'	±50'
	MAS DE 50 A 120 mm		±20'	±25'
	MAS DE 120 A 400 mm		±10'	±15'
	MAS DE 400 mm		±5'	±10'

COMUN A

MODELO	Ud.	MODELO	Ud.	MODELO	Ud.	MODELO	Ud.	MODELO	Ud.
MFP-270-4C	1								

	GRADO TOLERANCIA	FINO	MEDIO	GRUESO
LINEAL	HASTA 3 mm	±0,05	±0,10	±0,15
	MAS DE 3 A 6 mm	±0,05	±0,10	±0,20
	MAS DE 6 A 30 mm	±0,10	±0,20	±0,50
	MAS DE 30 A 120 mm	±0,15	±0,30	±0,80
	MAS DE 120 A 400 mm	±0,20	±0,50	±1,20
	MAS DE 400 A 1000 mm	±0,30	±0,80	±2,00
	MAS DE 1000 A 2000 mm	±0,50	±1,20	±3,00

A4

Nombre

Fecha

Dibujado

A.J.GONZALEZ

Feb-2011

Modificado

Escala

1:30



F A G O R I

RECAAMBIOS MFP-270-4C/GN

Código máquina:

Вип-Общепит

vsezip.ru

+7(812)987-08-88

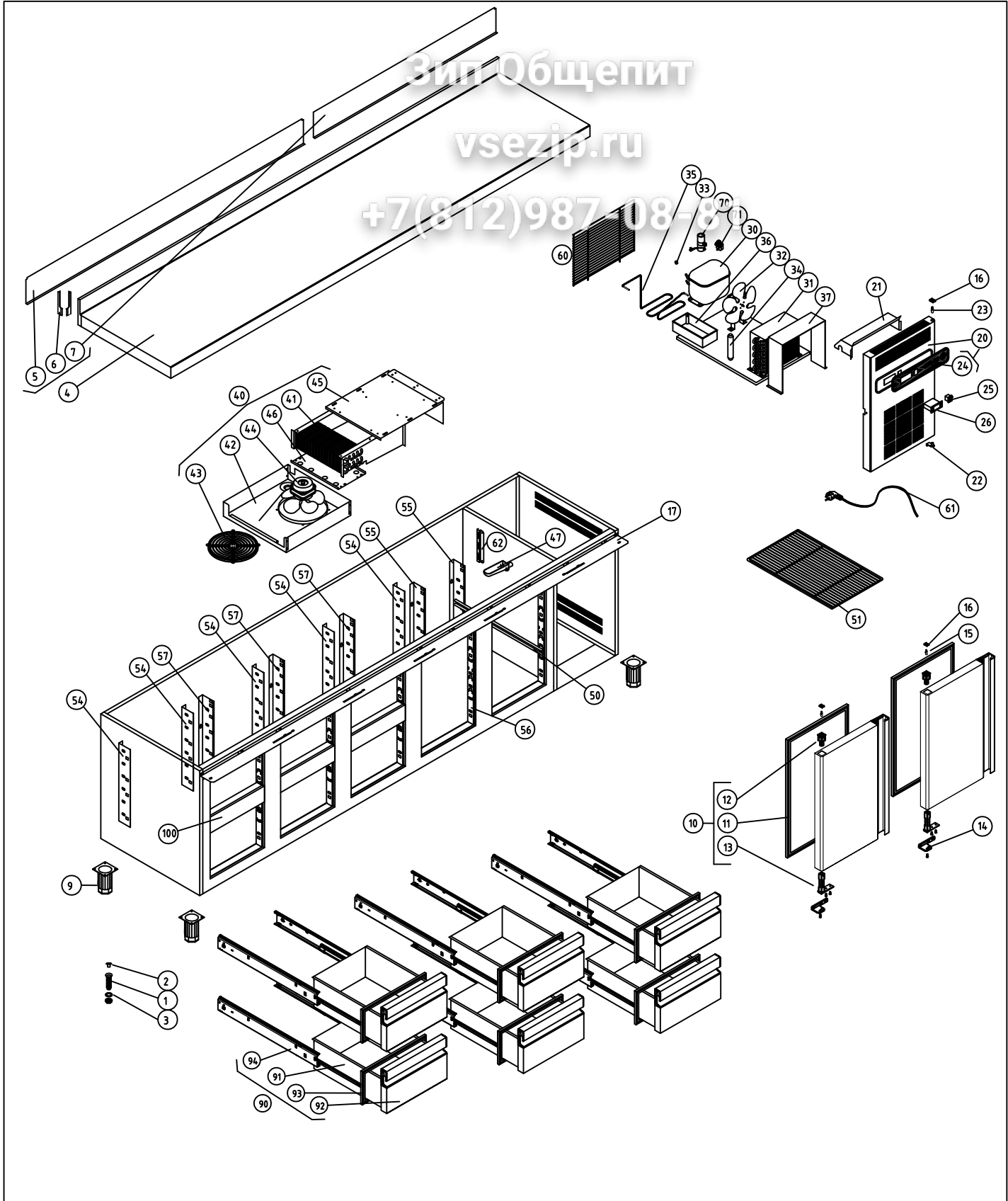

M1 MESAS FRIAS						COD. PIEZA: 148314060000							
COTAS SIN TOLERANCIA DIN 7168-f						Material: .							
ANGULAR	GRADO TOLERANCIA	FINO	MEDIO	GRUESO	Acabado: .				SUSTITUYE A:				
	HASTA 10 mm		±1°	±1° 30'	SUSTITUIDO POR:								
	MAS DE 10 A 50 mm		±30'	±50'	MODELO	Ud.	MODELO	Ud.	MODELO	Ud.	MODELO	Ud.	MODELO
	MAS DE 50 A 120 mm		±20'	±25'	MFP-270-6C	1							
	MAS DE 120 A 400 mm		±10'	±15'									
MAS DE 400 mm		±5'	±10'										
LINEAL	GRADO TOLERANCIA	FINO	MEDIO	GRUESO	A4		Nombre		Fecha				
	HASTA 3 mm	±0,05	±0,10	±0,15	Dibujado		A.J.GONZALEZ		Feb-2011				
	MAS DE 3 A 6 mm	±0,05	±0,10	±0,20	Modificado								
	MAS DE 6 A 30 mm	±0,10	±0,20	±0,50	Escala								
	MAS DE 30 A 120 mm	±0,15	±0,30	±0,80									
	MAS DE 120 A 400 mm	±0,20	±0,50	±1,20									
MAS DE 400 A 1000 mm	±0,30	±0,80	±2,00										
MAS DE 1000 A 2000 mm	±0,50	±1,20	±3,00										
						RECAAMBIOS MFP-270-6C/GN							
						Código máquina:							

Вип-Общепит

vsezip.ru

+7(812)987-08-88

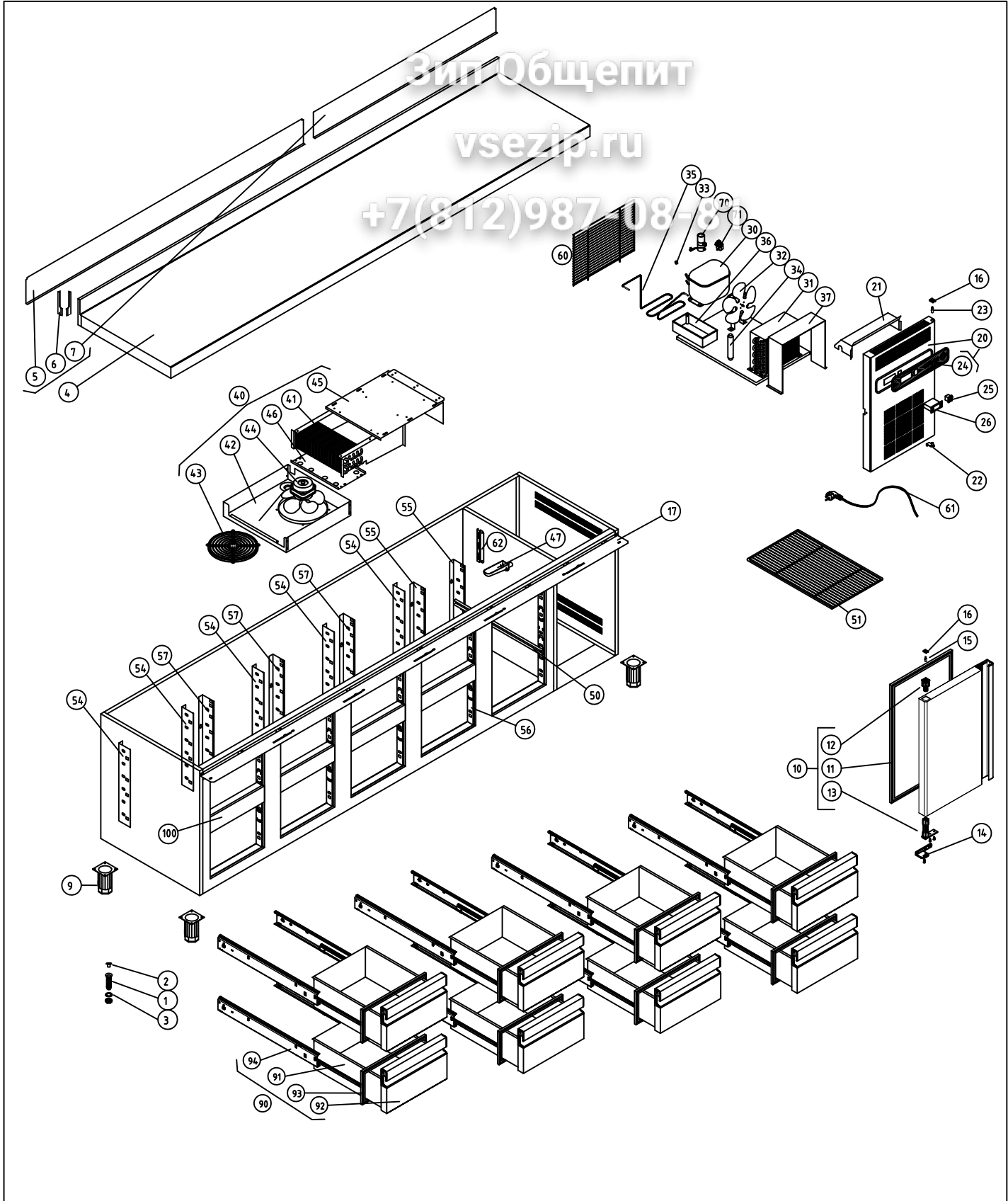

M1 MESAS FRIAS						COD. PIEZA: 148314080000						
COTAS SIN TOLERANCIA DIN 7168-f						Material: .						
ANGULAR	GRADO TOLERANCIA	FINO	MEDIO	GRUESO	Acabado: .							
	HASTA 10 mm		±1°	±1° 30'	SUSTITUYE A:							
	MAS DE 10 A 50 mm		±30'	±50'	SUSTITUIDO POR:							
	MAS DE 50 A 120 mm		±20'	±25'	MODELO	Ud.	MODELO	Ud.	MODELO	Ud.	MODELO	Ud.
	MAS DE 120 A 400 mm		±10'	±15'	MFP-270-8C	1						
MAS DE 400 mm		±5'	±10'	COMUN A								
LINEAL	GRADO TOLERANCIA	FINO	MEDIO	GRUESO	A4		Nombre		Fecha			
	HASTA 3 mm	±0,05	±0,10	±0,15	Dibujado		A.J.GONZALEZ		Feb-2011			
	MAS DE 3 A 6 mm	±0,05	±0,10	±0,20	Modificado							
	MAS DE 6 A 30 mm	±0,10	±0,20	±0,50	Escala							
	MAS DE 30 A 120 mm	±0,15	±0,30	±0,80	1:30		RECAAMBIOS MFP-270-8C/GN		Código máquina:			
MAS DE 120 A 400 mm	±0,20	±0,50	±1,20									
MAS DE 400 A 1000 mm	±0,30	±0,80	±2,00									
MAS DE 1000 A 2000 mm	±0,50	±1,20	±3,00									





F A G O R I

Вип-Общепит

vsezip.ru

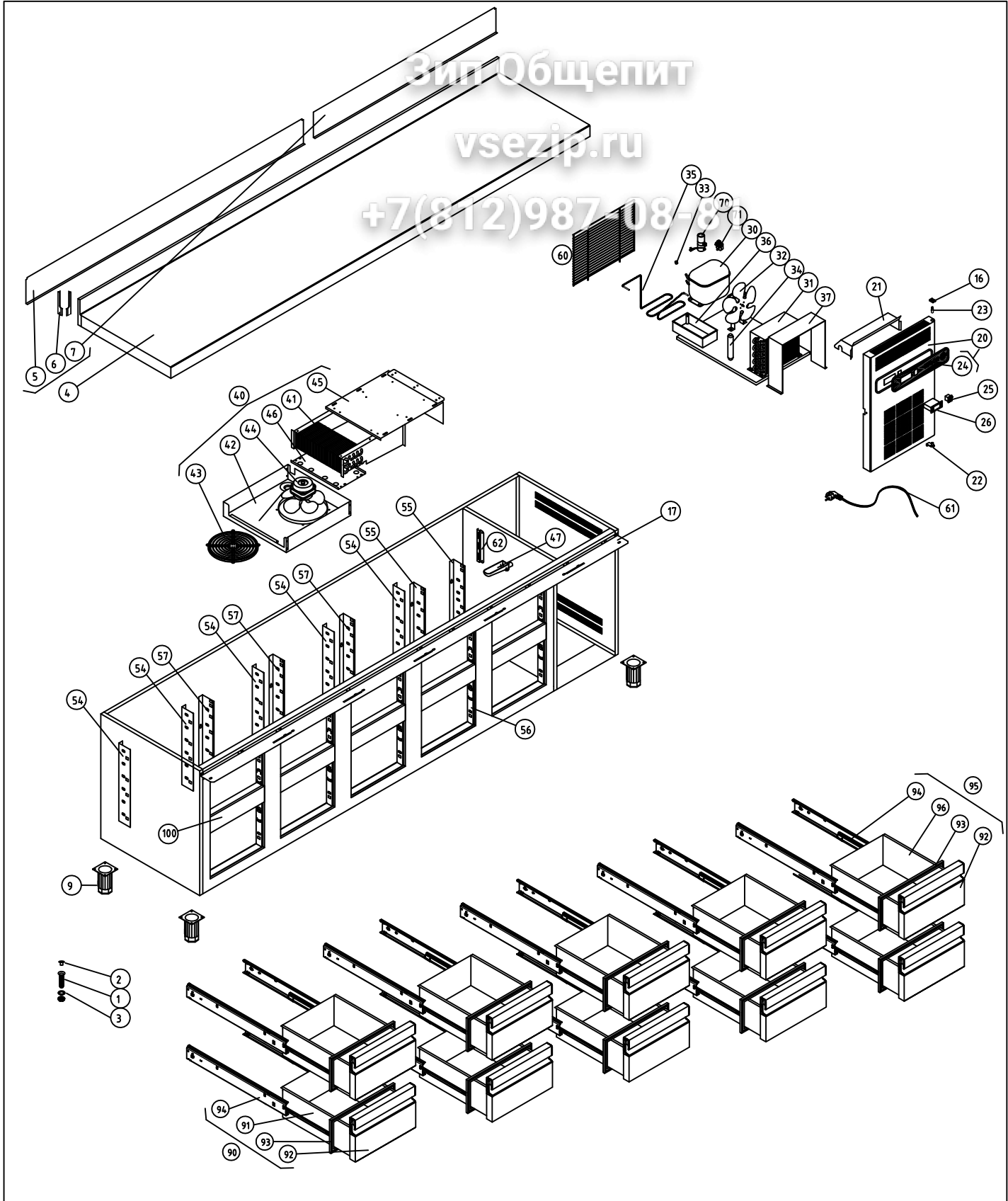
+7(812)987-08-88



M1 MESAS FRIAS						COD. PIEZA: 148314090000						
COTAS SIN TOLERANCIA DIN 7168-f						Material: .						
ANGULAR	GRADO TOLERANCIA	FINO	MEDIO	GRUESO	Acabado: .							
	HASTA 10 mm		±1°	±1° 30'	SUSTITUYE A:							
	MAS DE 10 A 50 mm		±30'	±50'	SUSTITUIDO POR:							
	MAS DE 50 A 120 mm		±20'	±25'	MODELO	Ud.	MODELO	Ud.	MODELO	Ud.	MODELO	Ud.
	MAS DE 120 A 400 mm		±10'	±15'	MFP-270-10C	1						
MAS DE 400 mm		±5'	±10'	COMUN A								
LINEAL	GRADO TOLERANCIA	FINO	MEDIO	GRUESO	A4		Nombre		Fecha		 F A G O R I	
	HASTA 3 mm	±0,05	±0,10	±0,15	Dibujado		A.J.GONZALEZ		Feb-2011			
	MAS DE 3 A 6 mm	±0,05	±0,10	±0,20	Modificado		.		.			
	MAS DE 6 A 30 mm	±0,10	±0,20	±0,50	Escala		RECAAMBIOS MFP-270-10C/GN					
	MAS DE 30 A 120 mm	±0,15	±0,30	±0,80	1:30		Código máquina:					
MAS DE 120 A 400 mm	±0,20	±0,50	±1,20									
MAS DE 400 A 1000 mm	±0,30	±0,80	±2,00									
MAS DE 1000 A 2000 mm	±0,50	±1,20	±3,00									

Зип Общепит

vsezip.ru

+7(812)987-08-81

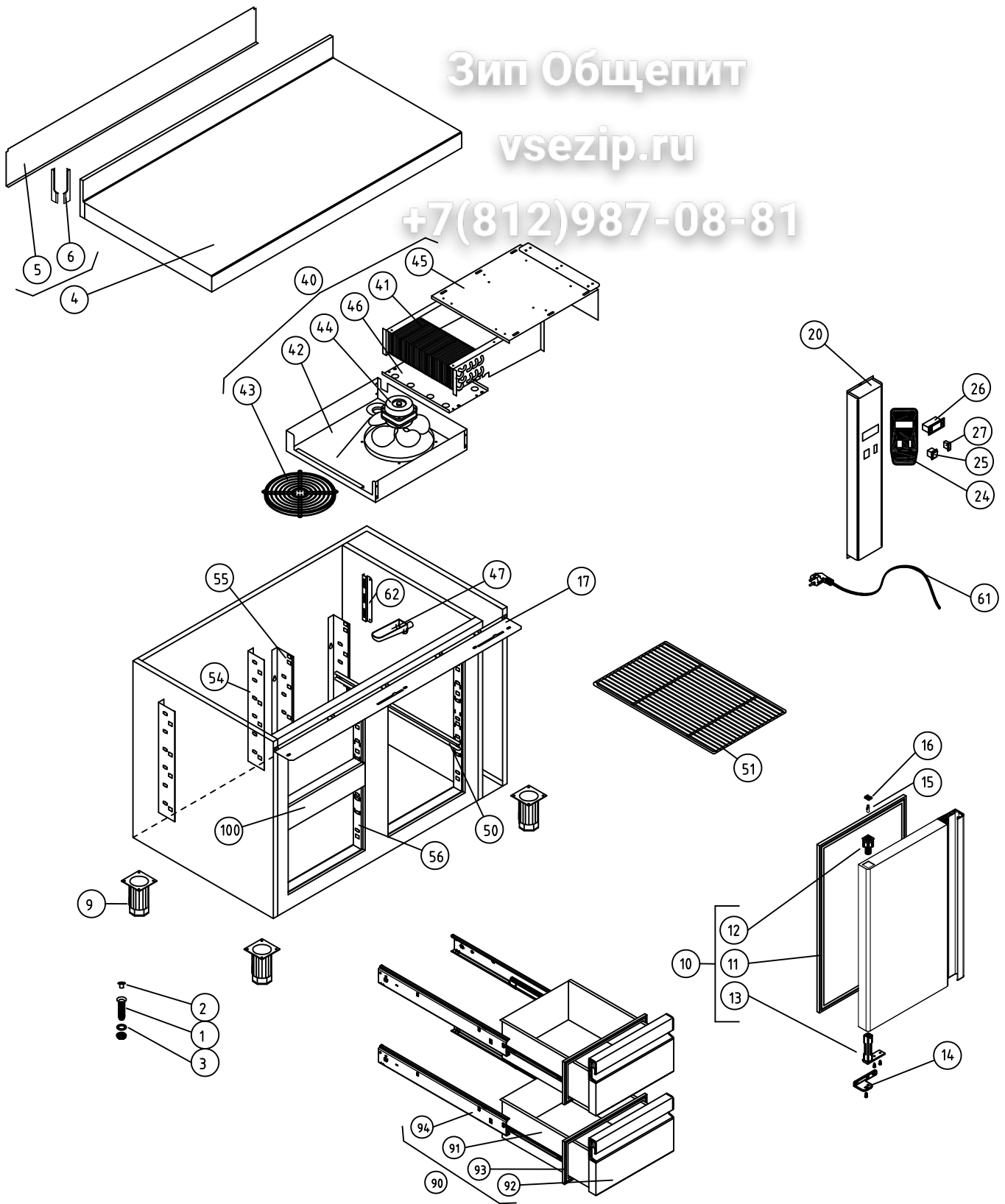

M1 MESAS FRÍAS

COD. PIEZA: 148311021000

COTAS SIN TOLERANCIA DIN 7168-f

Material: MATERIAL ESPESOR

SUSTITUYE A:

Acabado: ACABADO

SUSTITUIDO POR:

ANGULAR	GRADO TOLERANCIA	FINO	MEDIO	GRUESO
	HASTA 10 mm		±1°	±1° 30'
	MÁS DE 10 A 50 mm		±30'	±50'
	MÁS DE 50 A 120 mm		±20'	±25'
	MÁS DE 120 A 400 mm		±10'	±15'
MÁS DE 400 mm		±5'	±10'	

COMUN A	MODELO	Ud.	MODELO	Ud.	MODELO	Ud.	MODELO	Ud.	MODELO	Ud.
	MFP-102-R2C	1								

LINEAL	GRADO TOLERANCIA	FINO	MEDIO	GRUESO
	HASTA 3 mm	±0,05	±0,10	±0,15
	MÁS DE 3 A 6 mm	±0,05	±0,10	±0,20
	MÁS DE 6 A 30 mm	±0,10	±0,20	±0,50
	MÁS DE 30 A 120 mm	±0,15	±0,30	±0,80
	MÁS DE 120 A 400 mm	±0,20	±0,50	±1,20
MÁS DE 400 A 1000 mm	±0,30	±0,80	±2,00	
MÁS DE 1000 A 2000 mm	±0,50	±1,20	±3,00	

A4	Nombre	Fecha	 <p>F A G O R I</p>
Dibujado	A.J.GONZALEZ	Feb-2011	
Modificado	.	.	
Escala	1:22		RECAMBIOS MFP-102-R2C/GN

Зип Общепит

vsezip.ru

+7(812)987-08-81

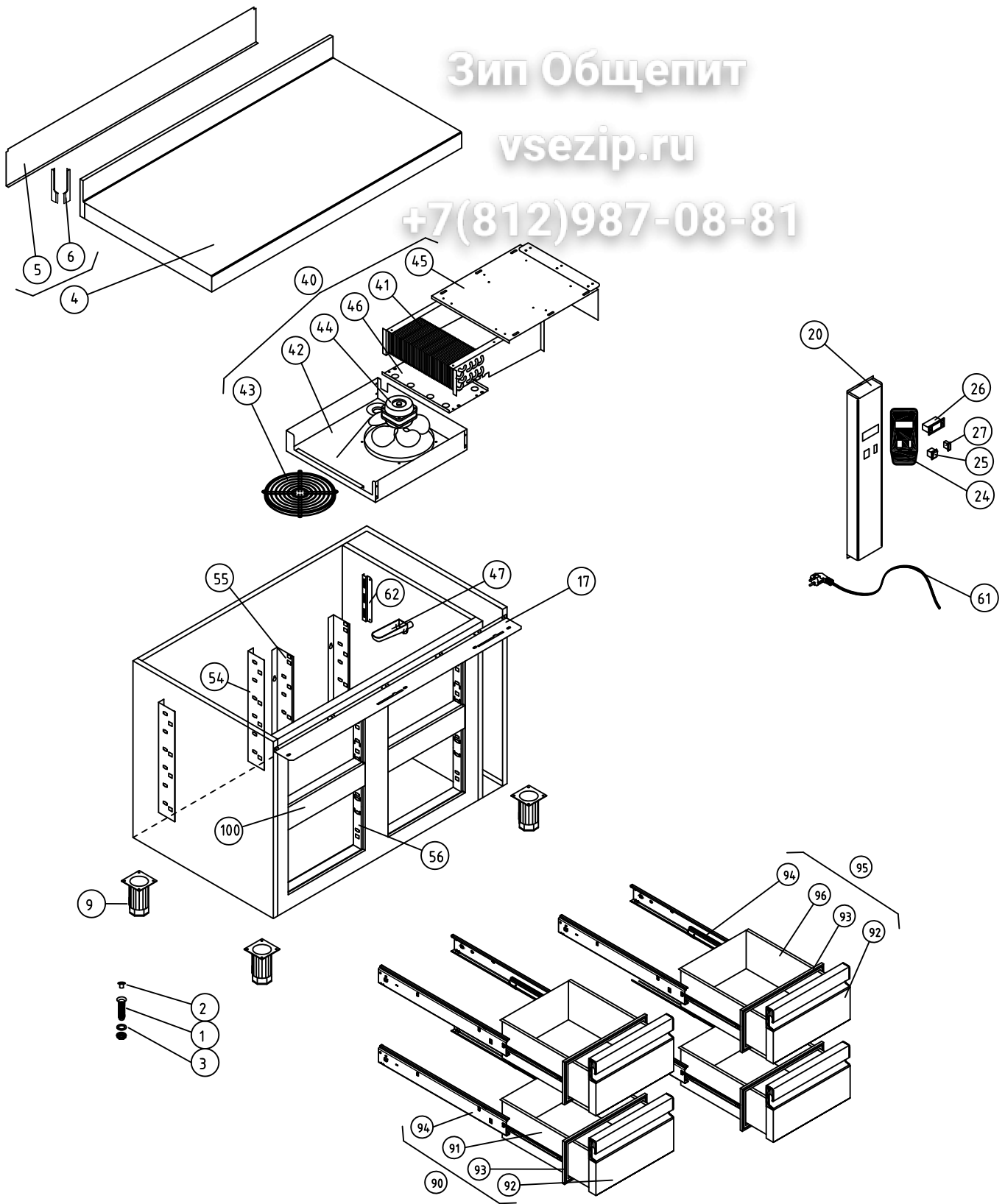

M1 MESAS FRÍAS

COD. PIEZA: 148311041000

COTAS SIN TOLERANCIA DIN 7168-f

Material: MATERIAL ESPESOR

SUSTITUYE A:

Acabado: ACABADO

SUSTITUIDO POR:

ANGULAR	GRADO TOLERANCIA	FINO	MEDIO	GRUESO
	HASTA 10 mm		±1°	±1° 30'
	MAS DE 10 A 50 mm		±30'	±50'
	MAS DE 50 A 120 mm		±20'	±25'
	MAS DE 120 A 400 mm		±10'	±15'
MAS DE 400 mm		±5'	±10'	

COMUN A	MODELO	Ud.	MODELO	Ud.	MODELO	Ud.	MODELO	Ud.	MODELO	Ud.
	MFP-102-R4C	1								

LINEAL	GRADO TOLERANCIA	FINO	MEDIO	GRUESO
	HASTA 3 mm	±0,05	±0,10	±0,15
	MAS DE 3 A 6 mm	±0,05	±0,10	±0,20
	MAS DE 6 A 30 mm	±0,10	±0,20	±0,50
	MAS DE 30 A 120 mm	±0,15	±0,30	±0,80
	MAS DE 120 A 400 mm	±0,20	±0,50	±1,20
MAS DE 400 A 1000 mm	±0,30	±0,80	±2,00	
MAS DE 1000 A 2000 mm	±0,50	±1,20	±3,00	

A4	Nombre	Fecha	 <p>F A G O R I</p>
Dibujado	A.J.GONZALEZ	Feb-2011	
Modificado	.	.	
Escala	1:22		RECAMBIOS MFP-102-R4C/GN
			Código máquina: CODIGO

Зип Общепит

vsezip.ru

+7(812)987-08-81

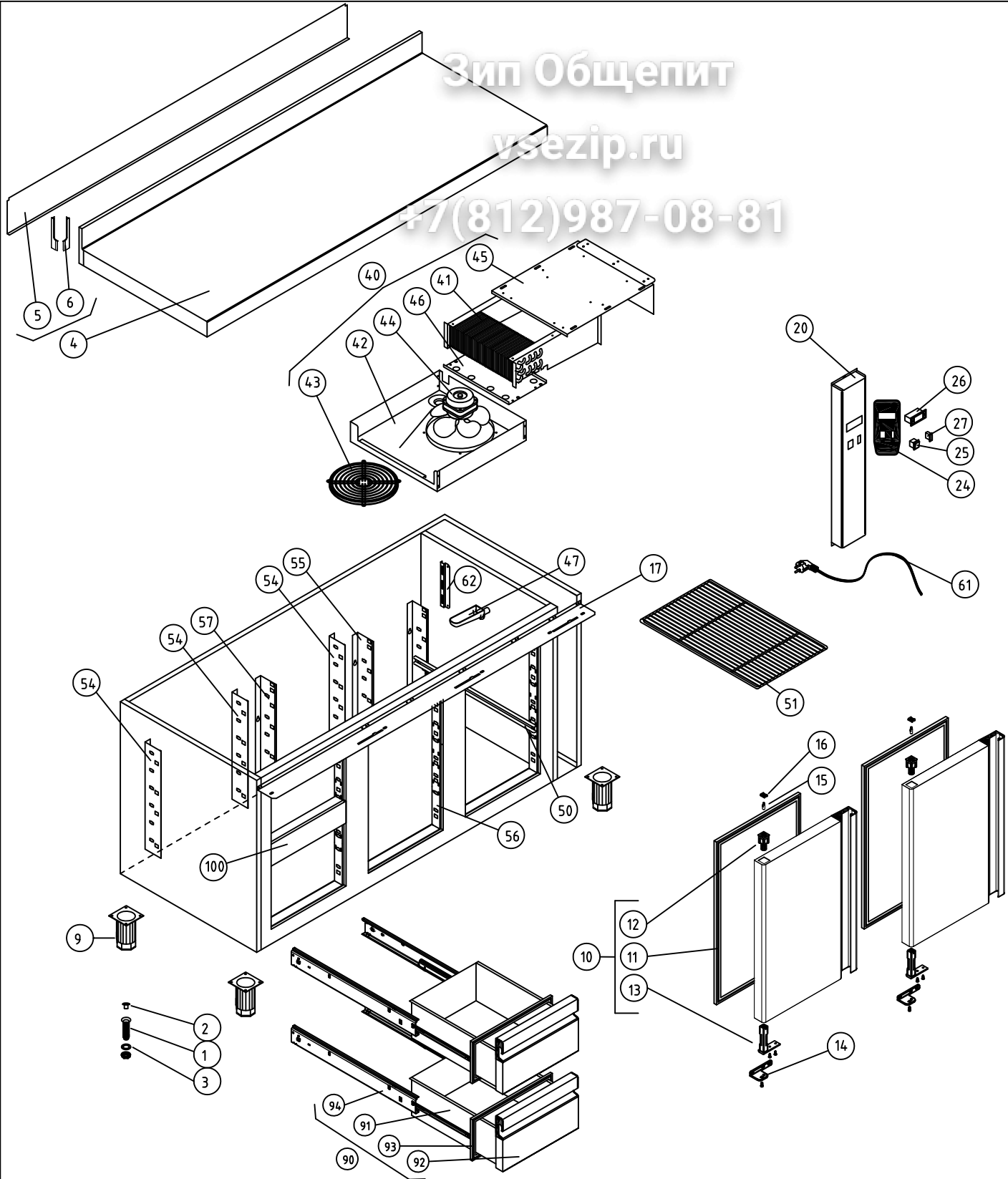

M1 MESAS FRÍAS COD. PIEZA: 148312021000

COTAS SIN TOLERANCIA DIN 7168-f Material: .

Acabado: . SUSTITUYE A: .

SUSTITUIDO POR: .

ANGULAR	GRADO TOLERANCIA	FINO	MEDIO	GRUESO
	HASTA 10 mm		±1°	±1° 30'
MÁS DE 10 A 50 mm		±30'	±50'	
MÁS DE 50 A 120 mm		±20'	±25'	
MÁS DE 120 A 400 mm		±10'	±15'	
MÁS DE 400 mm		±5'	±10'	

LINEAL	GRADO TOLERANCIA	FINO	MEDIO	GRUESO
	HASTA 3 mm		±0,05	±0,10
MÁS DE 3 A 6 mm		±0,05	±0,10	±0,20
MÁS DE 6 A 30 mm		±0,10	±0,20	±0,50
MÁS DE 30 A 120 mm		±0,15	±0,30	±0,80
MÁS DE 120 A 400 mm		±0,20	±0,50	±1,20
MÁS DE 400 A 1000 mm		±0,30	±0,80	±2,00
MÁS DE 1000 A 2000 mm		±0,50	±1,20	±3,00

COMUN A	MODELO	Ud.	MODELO	Ud.	MODELO	Ud.	MODELO	Ud.	MODELO
	MFP-147-R2C	1							

A4	Nombre	Fecha
Dibujado	A.J.GONZALEZ	Feb-2011
Modificado		



Escala	1:22	RECAMBIOS MFP-147-R2C/GN	Código máquina:
--------	------	--------------------------	-----------------

Зип Общепит

vsezip.ru

+7(812)987-08-81

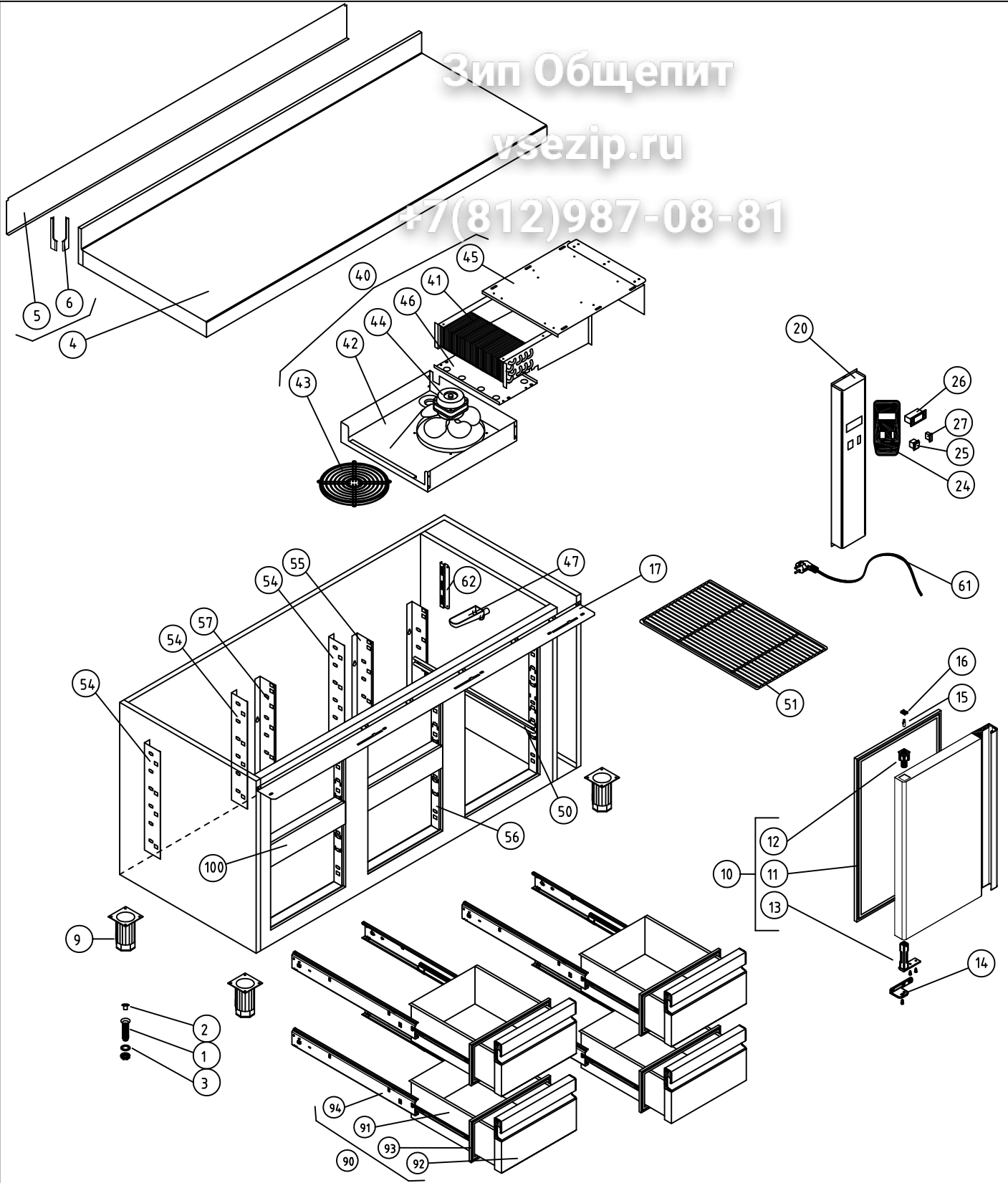

M1 MESAS FRÍAS COD. PIEZA: 148312041000

COTAS SIN TOLERANCIA DIN 7168-f Material: .

ANGULAR	GRADO TOLERANCIA	FINO	MEDIO	GRUESO
	HASTA 10 mm		±1°	±1° 30'
MÁS DE 10 A 50 mm		±30'	±50'	
MÁS DE 50 A 120 mm		±20'	±25'	
MÁS DE 120 A 400 mm		±10'	±15'	
MÁS DE 400 mm		±5'	±10'	

Acabado: . SUSTITUYE A:

COMUN A	MODELO	Ud.	MODELO	Ud.	MODELO	Ud.	MODELO	Ud.	MODELO
	MFP-147-R4C	1							

LINEAL	GRADO TOLERANCIA	FINO	MEDIO	GRUESO
	HASTA 3 mm		±0,05	±0,10
MÁS DE 3 A 6 mm		±0,05	±0,10	±0,20
MÁS DE 6 A 30 mm		±0,10	±0,20	±0,50
MÁS DE 30 A 120 mm		±0,15	±0,30	±0,80
MÁS DE 120 A 400 mm		±0,20	±0,50	±1,20
MÁS DE 400 A 1000 mm		±0,30	±0,80	±2,00
MÁS DE 1000 A 2000 mm		±0,50	±1,20	±3,00

A4 Nombre Fecha

Dibujado A.J.GONZALEZ Feb-2011

Modificado .

FAGOR

F A G O F R I

Escala 1:22 RECAMBIOS MFP-147-R4C/GN Código máquina:

Зип Общепит

vsezip.ru

+7(812)987-08-81

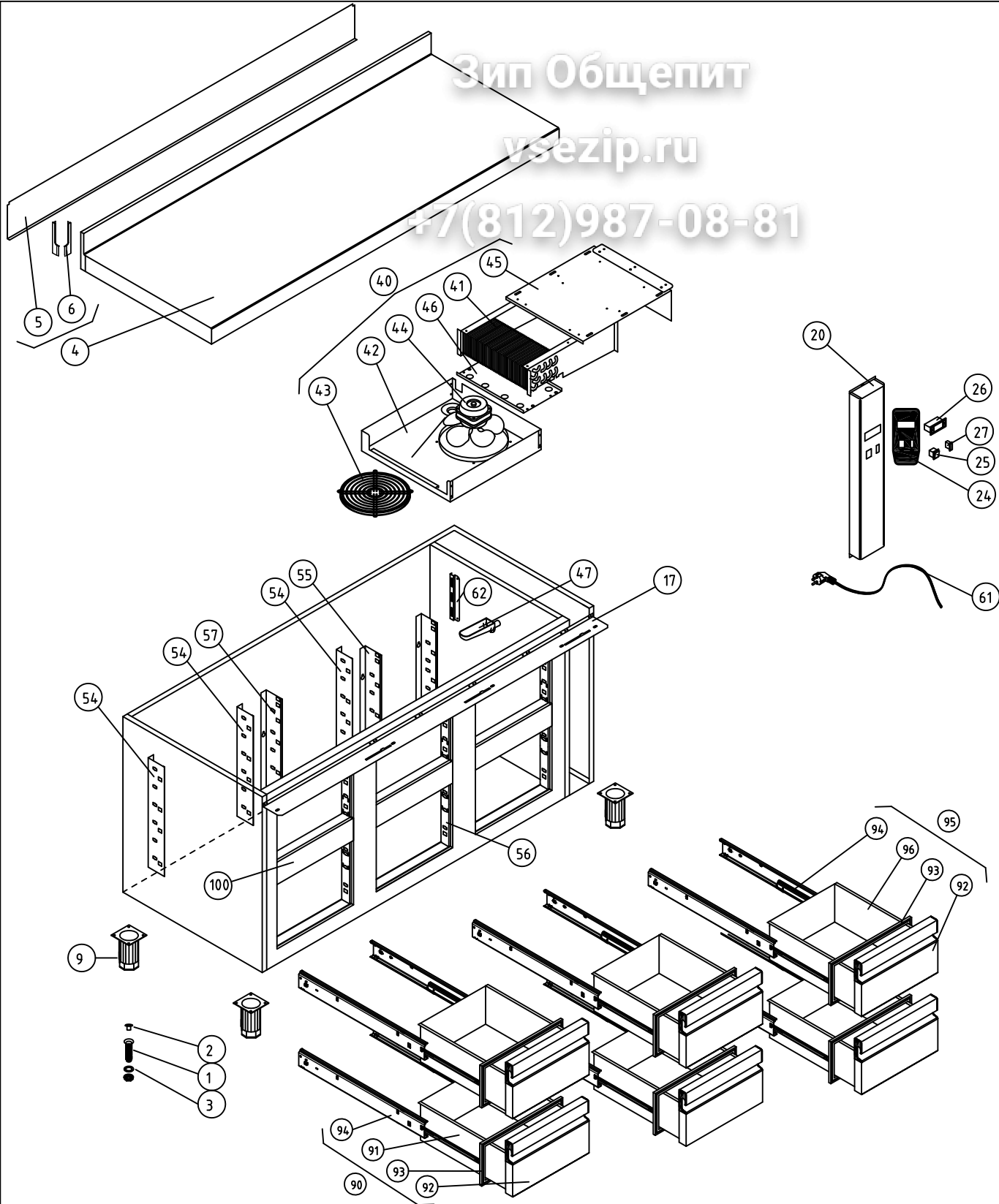

M1 MESAS FRÍAS COD. PIEZA: 148312061000

COTAS SIN TOLERANCIA DIN 7168-f Material: .

	GRADO TOLERANCIA	FINO	MEDIO	GRUESO
ANGULAR	HASTA 10 mm	±1°	±1° 30'	
	MÁS DE 10 A 50 mm	±30'	±50'	
	MÁS DE 50 A 120 mm	±20'	±25'	
	MÁS DE 120 A 400 mm	±10'	±15'	
	MÁS DE 400 mm	±5'	±10'	

Acabado: . SUSTITUYE A: .

COMUN A	MODELO	Ud.	MODELO	Ud.	MODELO	Ud.	MODELO	Ud.	MODELO	Ud.
	MFP-147-R6C	1								

	GRADO TOLERANCIA	FINO	MEDIO	GRUESO
LINEAL	HASTA 3 mm	±0,05	±0,10	±0,15
	MÁS DE 3 A 6 mm	±0,05	±0,10	±0,20
	MÁS DE 6 A 30 mm	±0,10	±0,20	±0,50
	MÁS DE 30 A 120 mm	±0,15	±0,30	±0,80
	MÁS DE 120 A 400 mm	±0,20	±0,50	±1,20
MÁS DE 400 A 1000 mm	±0,30	±0,80	±2,00	
MÁS DE 1000 A 2000 mm	±0,50	±1,20	±3,00	

A4	Nombre	Fecha	FAGOR
Dibujado	A.J.GONZALEZ	Feb-2011	
Modificado	.	.	

Escala	RECAMBIOS MFP-147-R6C/GN	Código máquina:
1:22		

F A G O R I

Зип Общепит

ysezip.ru

+7(812)987-08-81

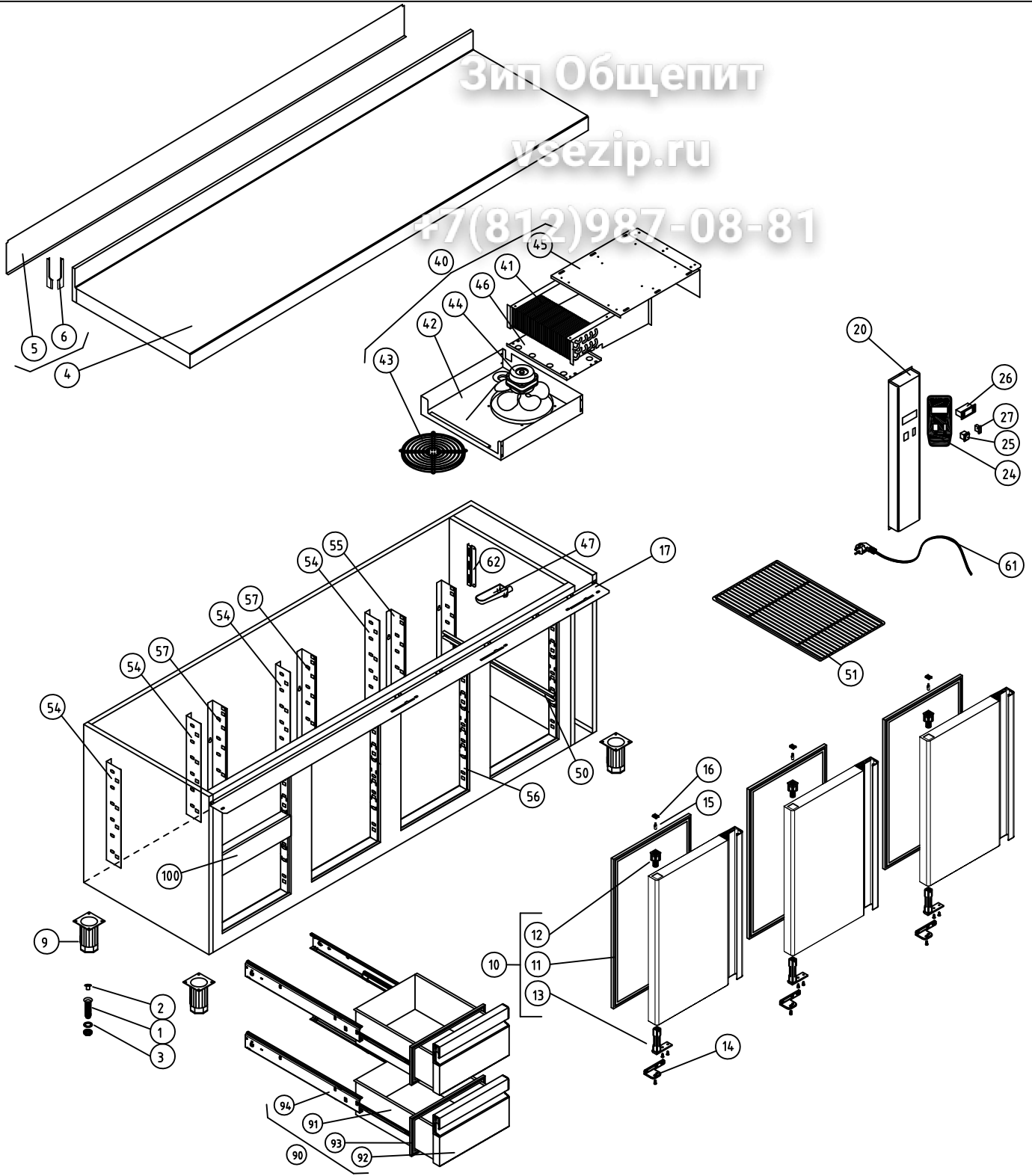

M1 MESAS FRÍAS COD. PIEZA: 148313021000

COTAS SIN TOLERANCIA DIN 7168-f SUSTITUYE A:
SUSTITUIDO POR:

	GRADO TOLERANCIA	FINO	MEDIO	GRUESO
ANGULAR	HASTA 10 mm		±1°	±1° 30'
	MÁS DE 10 A 50 mm		±30'	±50'
	MÁS DE 50 A 120 mm		±20'	±25'
	MÁS DE 120 A 400 mm		±10'	±15'
	MÁS DE 400 mm		±5'	±10'
LINEAL	HASTA 3 mm	±0,05	±0,10	±0,15
	MÁS DE 3 A 6 mm	±0,05	±0,10	±0,20
	MÁS DE 6 A 30 mm	±0,10	±0,20	±0,50
	MÁS DE 30 A 120 mm	±0,15	±0,30	±0,80
	MÁS DE 120 A 400 mm	±0,20	±0,50	±1,20
	MÁS DE 400 A 1000 mm	±0,30	±0,80	±2,00
	MÁS DE 1000 A 2000 mm	±0,50	±1,20	±3,00

Material: .
 Acabado: .

COMUN A	MODELO	Ud.	MODELO	Ud.	MODELO	Ud.	MODELO	Ud.	MODELO	Ud.
	MFP-192-R2C	1								

A4 Nombre Fecha
 Dibujado A.J.GONZALEZ Feb-2011
 Modificado .



Escala 1:25 RECAMBIOS MFP-192-R2C/GN Código máquina:

Зип Общепит

ysezip.ru

+7(812)987-08-81

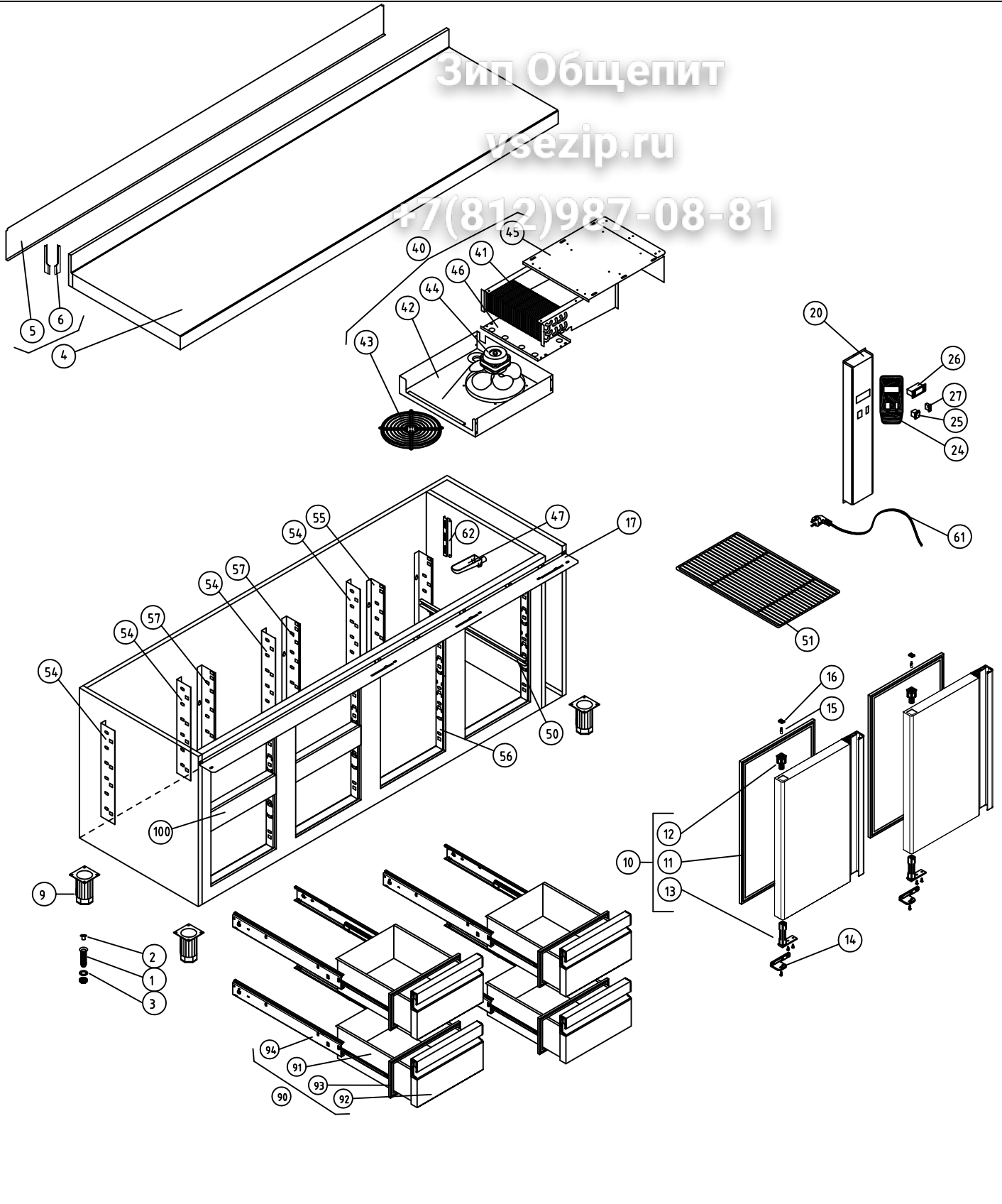

M1 MESAS FRÍAS COD. PIEZA: 148313041000

COTAS SIN TOLERANCIA DIN 7168-f Material: .

ANGULAR	GRADO TOLERANCIA	FINO	MEDIO	GRUESO
	HASTA 10 mm		±1°	±1° 30'
MÁS DE 10 A 50 mm		±30'	±50'	
MÁS DE 50 A 120 mm		±20'	±25'	
MÁS DE 120 A 400 mm		±10'	±15'	
MÁS DE 400 mm		±5'	±10'	

Acabado: .		SUSTITUYE A:							
SUSTITUIDO POR:									
COMUN A	MODELO	Ud.	MODELO	Ud.	MODELO	Ud.	MODELO	Ud.	MODELO
	MFP-192-R4C	1							

LINEAL	GRADO TOLERANCIA	FINO	MEDIO	GRUESO
	HASTA 3 mm		±0,05	±0,10
MÁS DE 3 A 6 mm		±0,05	±0,10	±0,20
MÁS DE 6 A 30 mm		±0,10	±0,20	±0,50
MÁS DE 30 A 120 mm		±0,15	±0,30	±0,80
MÁS DE 120 A 400 mm		±0,20	±0,50	±1,20
MÁS DE 400 A 1000 mm		±0,30	±0,80	±2,00
MÁS DE 1000 A 2000 mm		±0,50	±1,20	±3,00

A4	Nombre	Fecha
Dibujado	A.J.GONZALEZ	Feb-2011
Modificado		
Escala	1:25	

FAGOR

F A G O R I

RECAMBIOS MFP-192-R4C/GN

Código máquina:

Зип Общепит

ysezip.ru

+7(812)987-08-81

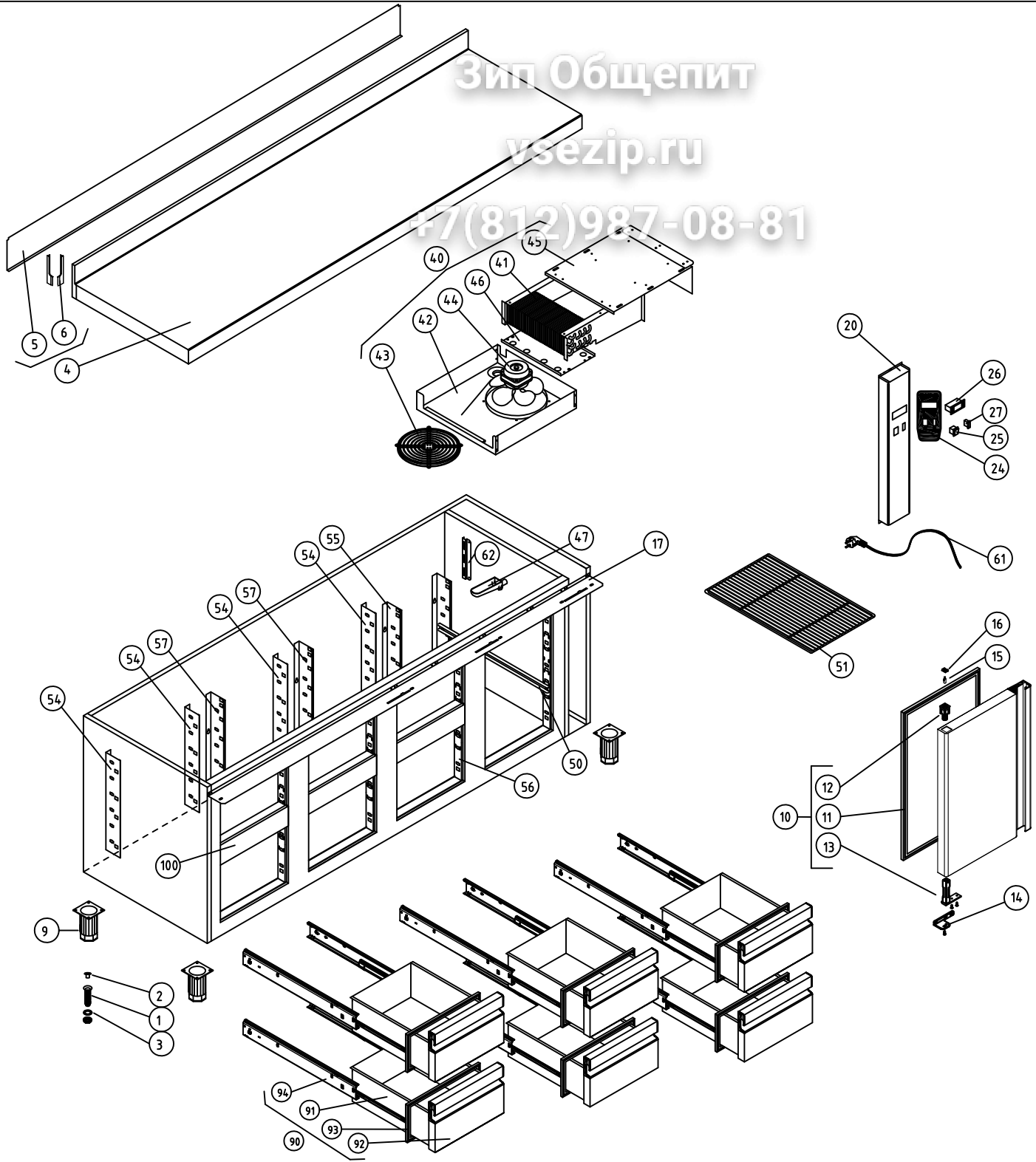

M1 MESAS FRÍAS

COD. PIEZA: 148313061000

COTAS SIN TOLERANCIA DIN 7168-f

Material: .

SUSTITUYE A: .

ANGULAR	GRADO TOLERANCIA	FINO	MEDIO	GRUESO
	HASTA 10 mm		±1°	±1° 30'
MÁS DE 10 A 50 mm		±30'	±50'	
MÁS DE 50 A 120 mm		±20'	±25'	
MÁS DE 120 A 400 mm		±10'	±15'	
MÁS DE 400 mm		±5'	±10'	

Acabado: .

SUSTITUIDO POR: .

LINEAL	GRADO TOLERANCIA	FINO	MEDIO	GRUESO
	HASTA 3 mm		±0,05	±0,10
MÁS DE 3 A 6 mm		±0,05	±0,10	±0,20
MÁS DE 6 A 30 mm		±0,10	±0,20	±0,50
MÁS DE 30 A 120 mm		±0,15	±0,30	±0,80
MÁS DE 120 A 400 mm		±0,20	±0,50	±1,20
MÁS DE 400 A 1000 mm		±0,30	±0,80	±2,00
MÁS DE 1000 A 2000 mm		±0,50	±1,20	±3,00

COMUN A	MODELO	Ud.	MODELO	Ud.	MODELO	Ud.	MODELO	Ud.	MODELO	Ud.
	MFP-192-R6C	1								

A4 Nombre Fecha
 Dibujado A.J.GONZALEZ Feb-2011
 Modificado .



Escala 1:25

RECAMBIOS MFP-192-R6C/GN
 Código máquina: .

Зип Общепит

ysezip.ru

+7(812)987-08-81

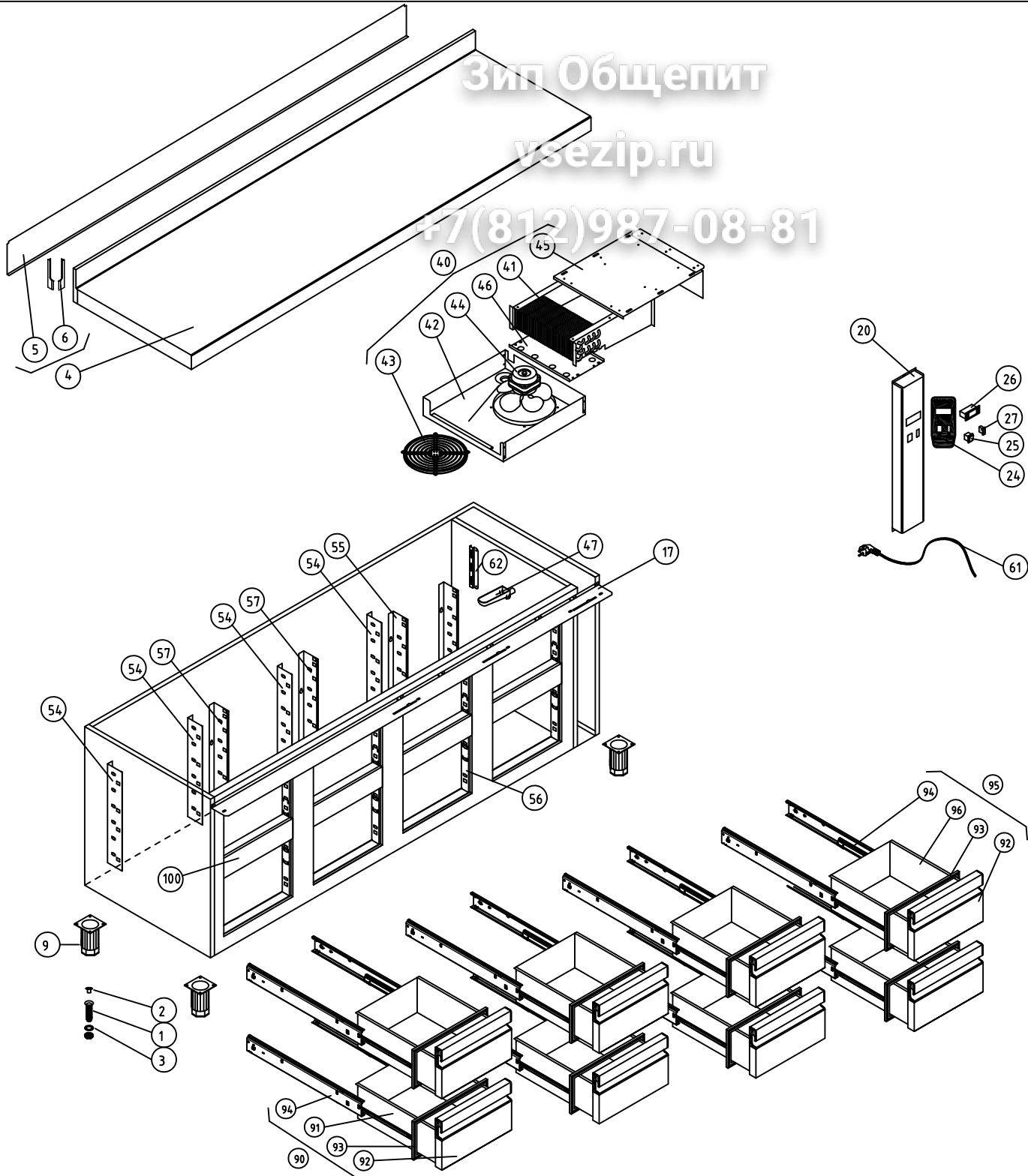

M1 MESAS FRÍAS

COD. PIEZA: 148313081000

COTAS SIN TOLERANCIA DIN 7168-f

Material: .

SUSTITUYE A:

ANGULAR	GRADO TOLERANCIA	FINO	MEDIO	GRUESO
	HASTA 10 mm		±1°	±1° 30'
MÁS DE 10 A 50 mm		±30'	±50'	
MÁS DE 50 A 120 mm		±20'	±25'	
MÁS DE 120 A 400 mm		±10'	±15'	
MÁS DE 400 mm		±5'	±10'	

Acabado: .

SUSTITUIDO POR:

ANGULAR	GRADO TOLERANCIA	FINO	MEDIO	GRUESO
	HASTA 3 mm		±0,05	±0,10
MÁS DE 3 A 6 mm		±0,05	±0,10	±0,20
MÁS DE 6 A 30 mm		±0,10	±0,20	±0,50
MÁS DE 30 A 120 mm		±0,15	±0,30	±0,80
MÁS DE 120 A 400 mm		±0,20	±0,50	±1,20
MÁS DE 400 A 1000 mm		±0,30	±0,80	±2,00
MÁS DE 1000 A 2000 mm		±0,50	±1,20	±3,00

COMUN A	MODELO	Ud.	MODELO	Ud.	MODELO	Ud.	MODELO	Ud.	MODELO	Ud.
	MFP-192-R8C	1								

LINEAL	GRADO TOLERANCIA	FINO	MEDIO	GRUESO
	HASTA 3 mm		±0,05	±0,10
MÁS DE 3 A 6 mm		±0,05	±0,10	±0,20
MÁS DE 6 A 30 mm		±0,10	±0,20	±0,50
MÁS DE 30 A 120 mm		±0,15	±0,30	±0,80
MÁS DE 120 A 400 mm		±0,20	±0,50	±1,20
MÁS DE 400 A 1000 mm		±0,30	±0,80	±2,00
MÁS DE 1000 A 2000 mm		±0,50	±1,20	±3,00

A4	Nombre	Fecha	
Dibujado	A.J.GONZALEZ	Feb-2011	
Modificado	.	.	

Escala	1:25	RECAMBIOS MFP-192-R8C/GN	Código máquina:
--------	------	--------------------------	-----------------

Зип Общепит

ysezip.ru

+7(812)987-08-81

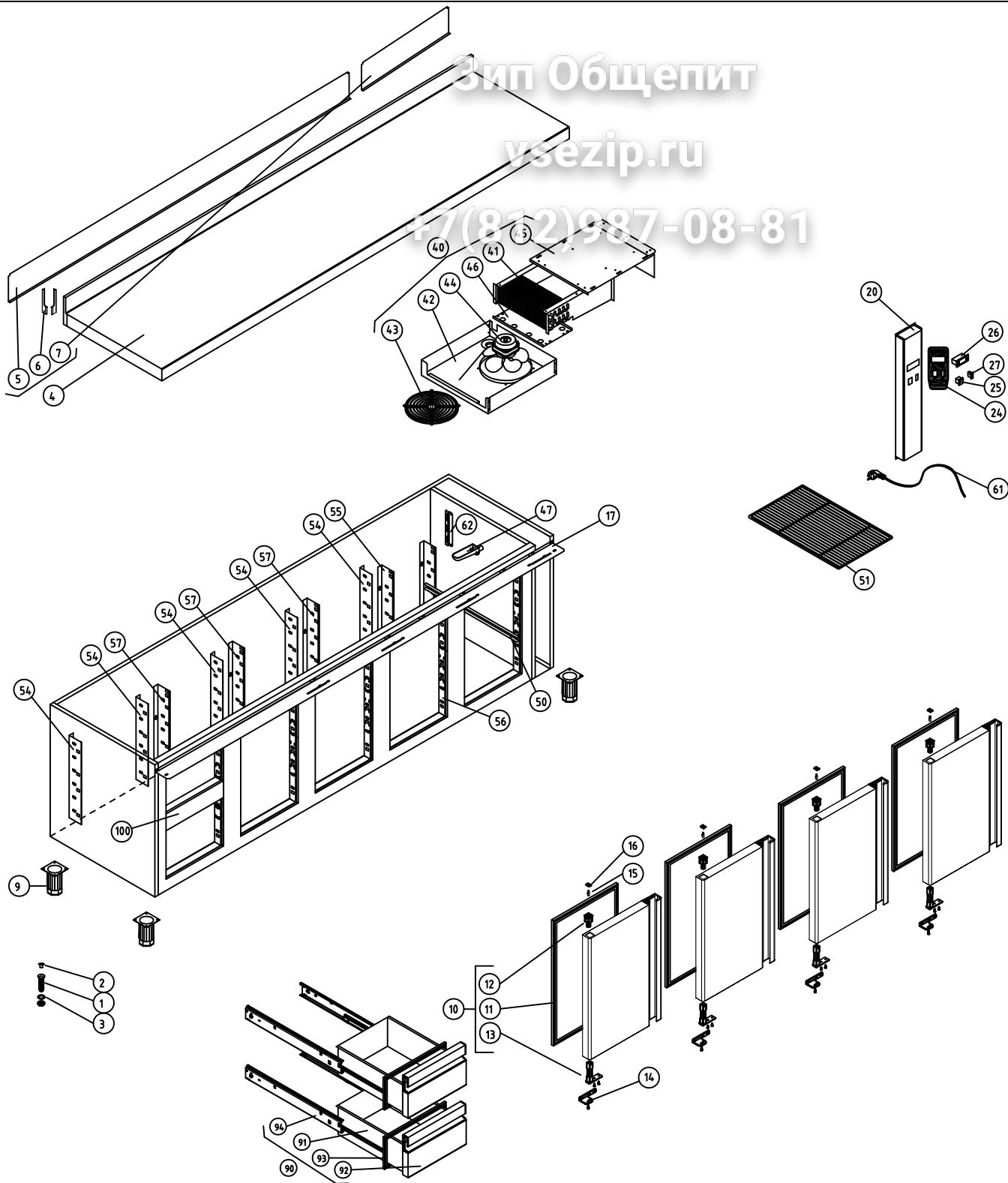

M1 MESAS FRÍAS

COD. PIEZA: 148314021000

COTAS SIN TOLERANCIA DIN 7168-f

Material: .

SUSTITUYE A:

Acabado: .

SUSTITUIDO POR:

ANGULAR	GRADO TOLERANCIA	FINO	MEDIO	GRUESO
	HASTA 10 mm		±1°	±1° 30'
	MAS DE 10 A 50 mm		±30'	±50'
	MAS DE 50 A 120 mm		±20'	±25'
	MAS DE 120 A 400 mm		±10'	±15'
MAS DE 400 mm		±5'	±10'	

COMUN A	MODELO	Ud.	MODELO	Ud.	MODELO	Ud.	MODELO	Ud.	MODELO	Ud.
	MFP-237-R2C	1								

LINEAL	GRADO TOLERANCIA	FINO	MEDIO	GRUESO
	HASTA 3 mm	±0,05	±0,10	±0,15
	MAS DE 3 A 6 mm	±0,05	±0,10	±0,20
	MAS DE 6 A 30 mm	±0,10	±0,20	±0,50
	MAS DE 30 A 120 mm	±0,15	±0,30	±0,80
MAS DE 120 A 400 mm	±0,20	±0,50	±1,20	
MAS DE 400 A 1000 mm	±0,30	±0,80	±2,00	
MAS DE 1000 A 2000 mm	±0,50	±1,20	±3,00	

A4	Nombre	Fecha	
Dibujado	A.J.GONZALEZ	Feb-2011	
Modificado	.	.	

Escala	1:30	RECAMBIOS MFP-237-R2C/GN	Código máquina:
--------	------	--------------------------	-----------------

Зип Общепит

ysezip.ru

+7(812)987-08-81

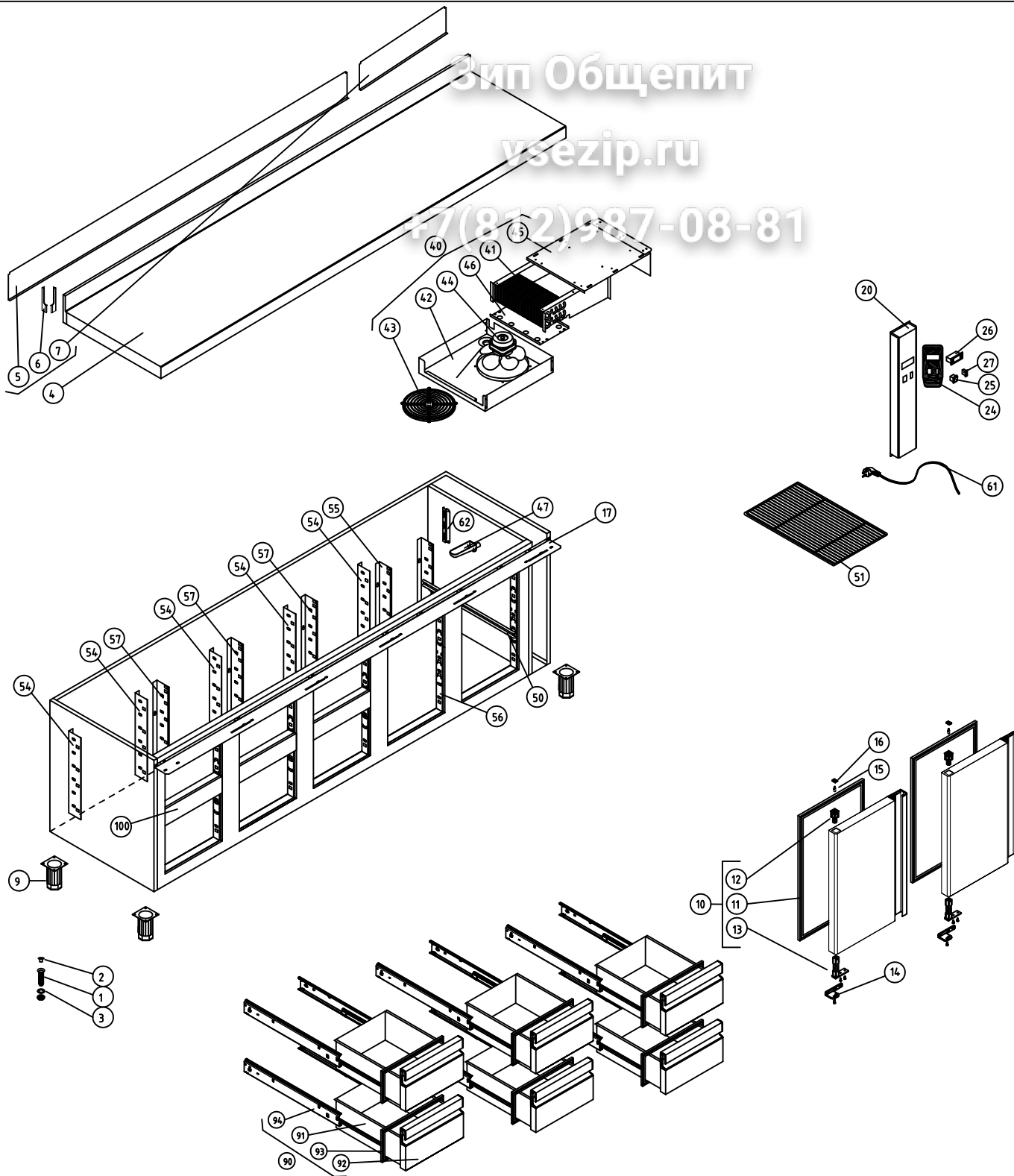

M1 MESAS FRÍAS

COD. PIEZA: 148314061000

COTAS SIN TOLERANCIA DIN 7168-f

Material: .

SUSTITUYE A:

Acabado: .

SUSTITUIDO POR:

ANGULAR	GRADO TOLERANCIA	FINO	MEDIO	GRUESO
	HASTA 10 mm		±1°	±1° 30'
	MÁS DE 10 A 50 mm		±30'	±50'
	MÁS DE 50 A 120 mm		±20'	±25'
	MÁS DE 120 A 400 mm		±10'	±15'
MÁS DE 400 mm		±5'	±10'	

COMUN A	MODELO	Ud.	MODELO	Ud.	MODELO	Ud.	MODELO	Ud.	MODELO	Ud.
	MFP-237-R6C	1								

LINEAL	GRADO TOLERANCIA	FINO	MEDIO	GRUESO
	HASTA 3 mm	±0,05	±0,10	±0,15
	MÁS DE 3 A 6 mm	±0,05	±0,10	±0,20
	MÁS DE 6 A 30 mm	±0,10	±0,20	±0,50
	MÁS DE 30 A 120 mm	±0,15	±0,30	±0,80
MÁS DE 120 A 400 mm	±0,20	±0,50	±1,20	
MÁS DE 400 A 1000 mm	±0,30	±0,80	±2,00	
MÁS DE 1000 A 2000 mm	±0,50	±1,20	±3,00	

A4	Nombre	Fecha	<p>F A G O R I</p>
Dibujado	A.J.GONZALEZ	Feb-2011	
Modificado			
Escala	1:30		Código máquina:
RECAMBIOS MFP-237-R6C/GN			

Зип Общепит

ysezip.ru

+7(812)987-08-81

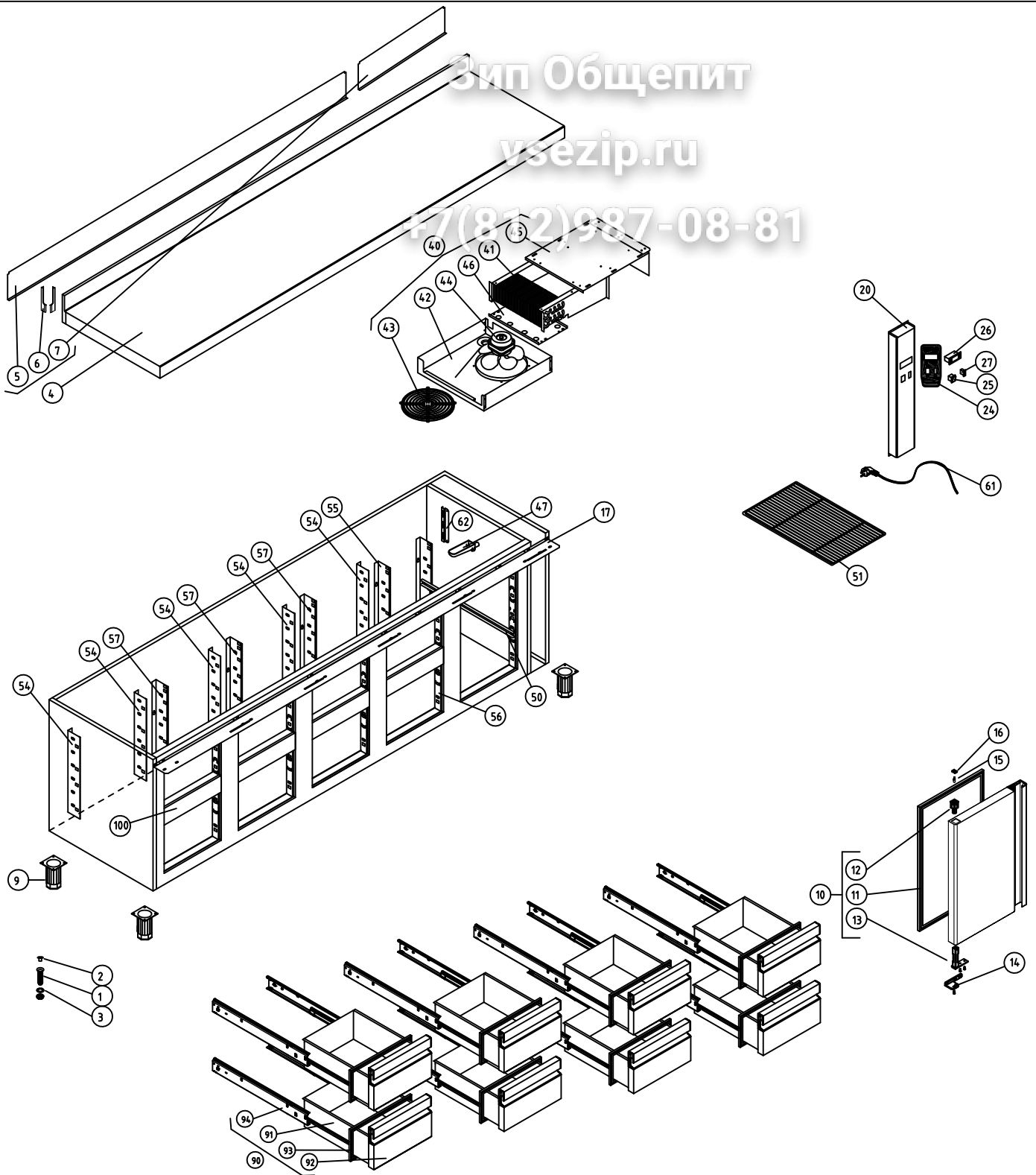

M1 MESAS FRÍAS

COD. PIEZA: 148314081000

COTAS SIN TOLERANCIA DIN 7168-f

Material: .

SUSTITUYE A:

Acabado: .

SUSTITUIDO POR:

ANGULAR	GRADO TOLERANCIA	FINO	MEDIO	GRUESO
	HASTA 10 mm		±1°	±1° 30'
	MÁS DE 10 A 50 mm		±30'	±50'
	MÁS DE 50 A 120 mm		±20'	±25'
	MÁS DE 120 A 400 mm		±10'	±15'
MÁS DE 400 mm		±5'	±10'	

COMUN A	MODELO	Ud.	MODELO	Ud.	MODELO	Ud.	MODELO	Ud.	MODELO	Ud.
	MFP-237-R8C	1								

LINEAL	GRADO TOLERANCIA	FINO	MEDIO	GRUESO
	HASTA 3 mm	±0,05	±0,10	±0,15
	MÁS DE 3 A 6 mm	±0,05	±0,10	±0,20
	MÁS DE 6 A 30 mm	±0,10	±0,20	±0,50
	MÁS DE 30 A 120 mm	±0,15	±0,30	±0,80
	MÁS DE 120 A 400 mm	±0,20	±0,50	±1,20
MÁS DE 400 A 1000 mm	±0,30	±0,80	±2,00	
MÁS DE 1000 A 2000 mm	±0,50	±1,20	±3,00	

A4	Nombre	Fecha
Dibujado	A.J.GONZALEZ	Feb-2011
Modificado	.	.



Escala
1:30

RECAMBIOS MFP-237-R8C/GN

Código máquina: