



Via Artigianato 85 – 25030 Torbole Casaglia (BRESCIA) ITALY – Tel. 0302650479 – Fax 0302650143

# INSTRUCTION BOOK

## PLANETARY MIXER BM30



<b>CHAPTER 1</b>	<b>TECHNICAL SPECIFICATIONS</b>	<b>1-1</b>
MACHINE SPECIFICATION.....		1-1
MACHINE DESCRIPTION .....		1-2
MACHINE COMMANDS.....		1-2
<b>CHAPTER 2</b>	<b>INSTALLATION, USE, MAINTENANCE</b>	<b>2-1</b>
INSTALLATION.....		2-1
OPERATING INSTRUCTIONS.....		2-1
MAINTENANCE.....		2-3
WIRING DIAGRAM.....		2-3
POSSIBLE FAULTS AND REPAIRS .....		2-4
<b>CHAPTER 3</b>	<b>EXPLODED DIAGRAMS</b>	<b>3-1</b>
EXPLODED VIEW – TABLE 1.....		3-1
EXPLODED VIEW – TABLE 2 .....		3-2
<b>CHAPTER 4</b>	<b>SPARE PARTS LIST</b>	<b>4-1</b>
LIST OF MACHINE PARTS.....		4-1
LIST OF RECOMMENDED SPARE PARTS.....		4-2

# Зип Общепит

## vsezip.ru

Net weight: Kg 130  
Bowl capacity: Lt. 30  
Power: Kw 1  
Tool speed: rpm max 160  
rpm min 40

### +7(812)987-08-81

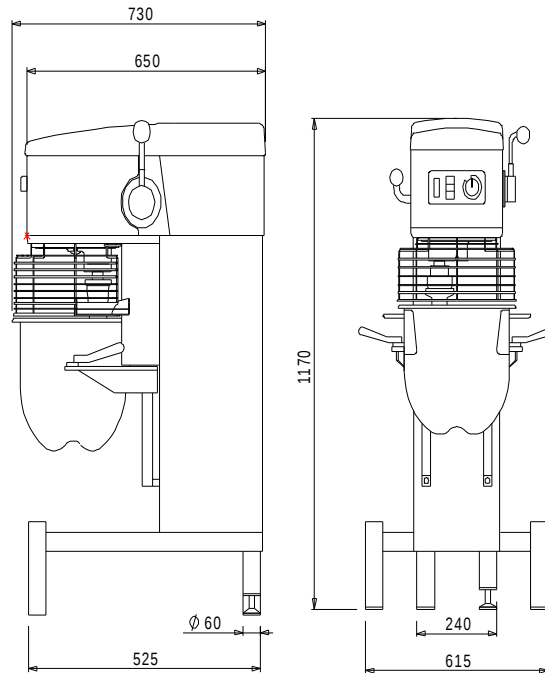

## RATING PLATE

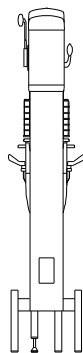

Mod.	<input type="text"/>	N°	<input type="text"/>
Hz	<input type="text"/>	Kw	<input type="text"/>
Volt	<input type="text"/>		
	<input type="text"/>		Manufactured in: ITALY
<b>SIGMA</b> <small>BAKERY PASTRY PIZZA EQUIPMENT</small>			
Via Artigianato, 85 - 25030 Torbole Casaglia - BRESCIA - ITALY Tel. 030/2650479-488 - Fax 030/2650143			

## MACHINE DESCRIPTION

The planetary mixers BM30 are designed for medium confectioneries, delicatessen and ice cream shop or they can also be used as auxiliary mixers. They are driven by a high-capacity motor and the special belt speed change variator features a great velocity ratio that provides a wide spread between the maximum and minimum speed of the planetary with consequent tool speed.

The speed change variator enables a perfect whipping, beating, mixing, combining and airing of all ingredients thus assuring excellent final products.

The properly hardened and ground gear unit and the wide size of the belt allow full use of installed power. The steel structure of the machines make them stout and reliable.

Bowl lowering device and easy removal of bowl and tools give to this machine a professional aspect.

Upmost care has been put in the construction of all fixtures provided, whisk, blade and spiral in stainless steel, which together with the peculiar form of the bowl, assure best results in mixing.

The safety devices and an electric control equipment complying with all European regulations crown these machines.

## MACHINE COMMANDS

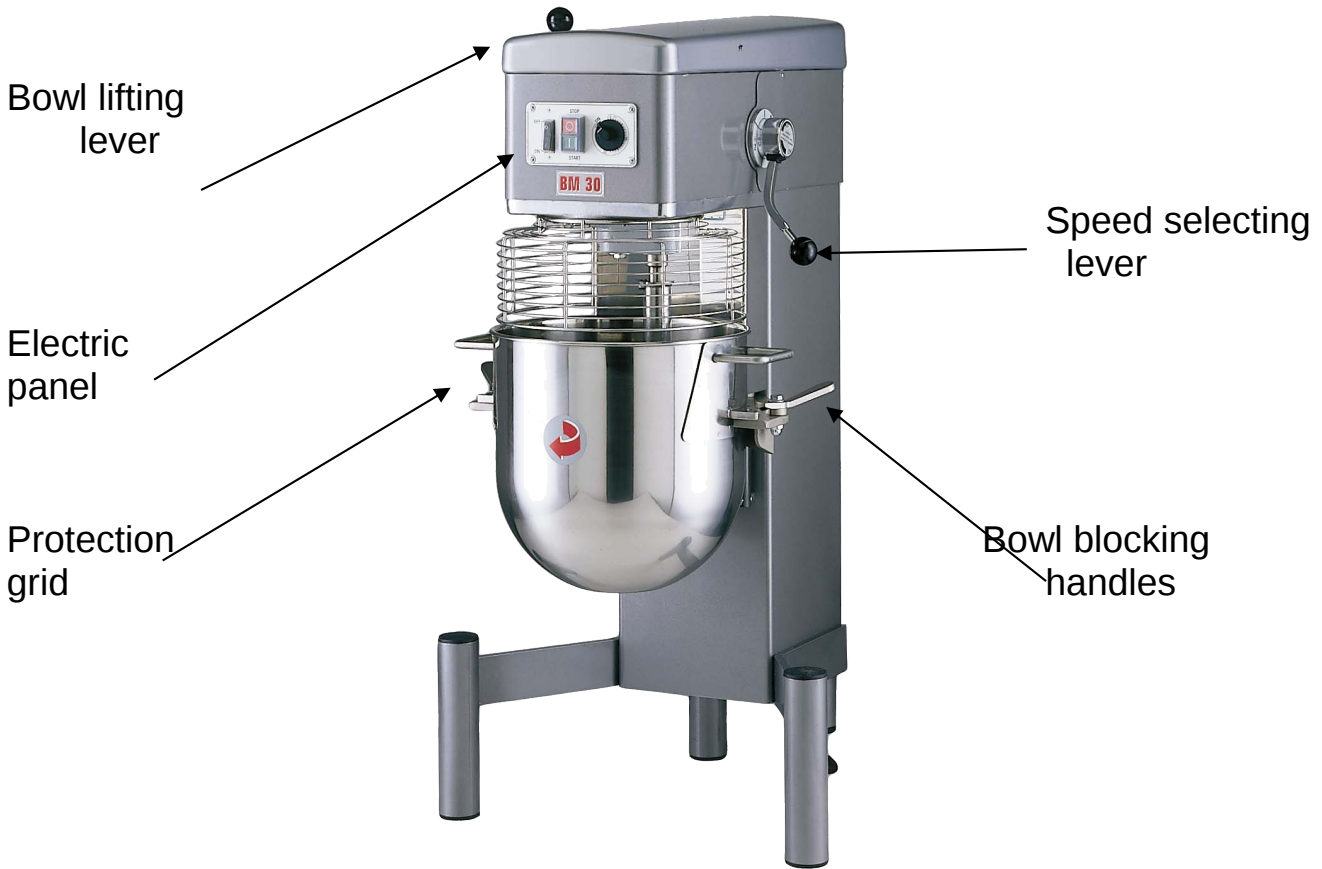

## INSTALLATION

The machine must be placed on the floor regulating its steadiness by means of the little foot that can be regulated in its highness..

Next to the machine, a lead must be installed, wires section of 1.5 mm<sup>2</sup> at least and tap with blocked plug.

Make sure that volt, Hz, kw comply with the ones indicated on the rating plate of the machine.

ATTENTION: At the start of the power supply a differential must be fitted with leakage current of 0,03A (Ampere).

## OPERATING INSTRUCTIONS

The machine must have the bowl attached and the protection grid closed otherwise the protections and safety devices prevent the mixer from working.

**DO NOT REMOVE OR TAMPER THE PROTECTIONS AND THE SAFETY DEVICES, EITHER ELECTRIC OR MECHANIC, THE MACHINE IS EQUIPPED WITH.**

1. The bowl must be attached to the mixer BEFORE attaching the agitators. Make sure that the bowl lift lever is in the down position.



2. Place the bowl onto the mixer making sure that the holes on each side are securely placed over the pins on the bowl support. Secure the bowl by pushing the bowl clamps on either side back so that the clamps rests on the bowls handles.



3. Rotate the bowl guard so that it rests in the open position and lower the bowl in its resting position. Select the appropriate tool and insert it onto the tool shaft. Move the agitator so that the notch on the agitator fits over the pin on the tool shaft as shown in the figure.



4. Lift completely up on the bowl lift lever until it locks into position. Insert the ingredients into the bowl and start the mixing process.



5. Press the main button (see pos.1 of the exploded view). Rotate the timer ( pos.3) into ON position so to have a continuous



# Зип Общепит

movement of the mixer or set the timer for the appropriate time, then press the start/stop button (pos.2). ATTENTION: when lifting the safety grid the machine immediately stops working, but the timer does not return to zero and goes on counting the elapsing time. It is therefore always advisable to wait for the end of the set time. After any mixing process reset the timer.

6. The mixer has a speed control lever to change the speed of the tools rotation. ATTENTION: NEVER move the speed control lever unless the mixer is operating otherwise the mixer will be damaged.



7. When the ingredients have been thoroughly mixed, press the stop button. Lower the bowl by pushing the bowl lift lever back and down to its resting position. Rotate the bowl guard so that it is in the open position. Rotate the tools anticlockwise for unhooking it and use levers to take the bowl with the tool out.



Many problems rise from an improper use of the machine by the end user. The overcoming of the advised quantities will be prejudicial to the quality of the working process and to the endurance of the mechanical parts of the machine. It will be useful to take as an indication about the maximum advised quantities the following capacity chart.

APPLICATION	INGREDIENTS	BM 10	BM 20	BM 30	BM 40	BM 60	TOOL	SPEED
Dough 55% water	Kg of flour	3	6	9	12	18	Spiral	1
Croissants dough	Kg of flour	2,5	5	7	9	15	Spiral	1
Cream puff dough	Kg of flour	2	4	6	8	12	Spiral	1
Meat	Kg.	5	10	15	20	30	Spiral/blade	1-2
Mashed potatoes	Kg of potatoes	5	10	15	20	30	Blade/Whisk	1-2
Albumen	Number of eggs	16	32	50	70	96	Whisk	1-4
Biscuits	Number of eggs	15	30	45	60	90	Whisk	1-3
Meringues	Kg of sugar	0,75	1,5	2,25	3	4,5	Whisk	1-4
Whipped cream	Lt of cream	2	4	5,5	7	10	Whisk	1-4

## MAINTENANCE

# Зип Общепит

ANY CHECK OR MAINTENANCE OPERATION SHOULD BE CARRIED OUT ONLY WHEN THE MIXER IS UNPLUGGED AND POWER IS DISCONNECTED.

The machine does not need particular maintenance operations. Check worn-out level of the belt after the first three months.

Periodically grease every 4 ÷ 6 months the points shown in the following sketch (use **MOLYKOTE 165 LT** ).

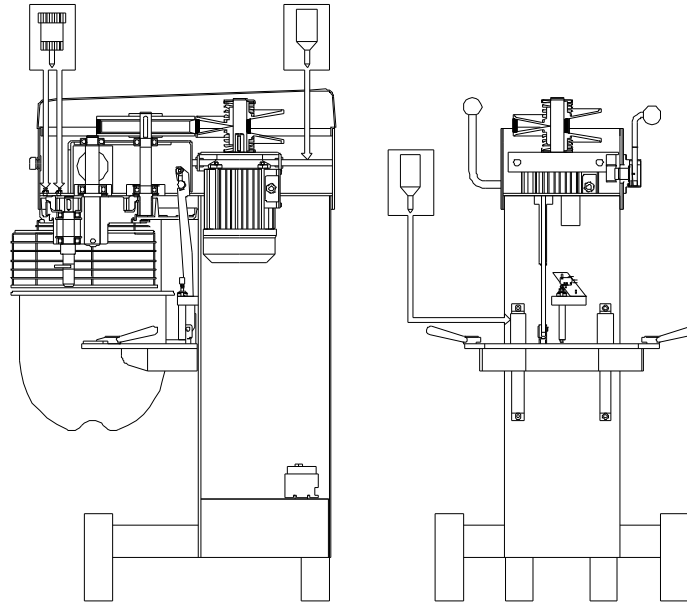

**ATTENTION:** The machine is not waterproof, therefore whatever cleaning process must not involve a jet of water.

If the power supply cable becomes damaged it must be substituted with a **H07RN/F** cable with a cross-sectional measurement of  $3 \times 1,5 \text{ mm}^2$  .

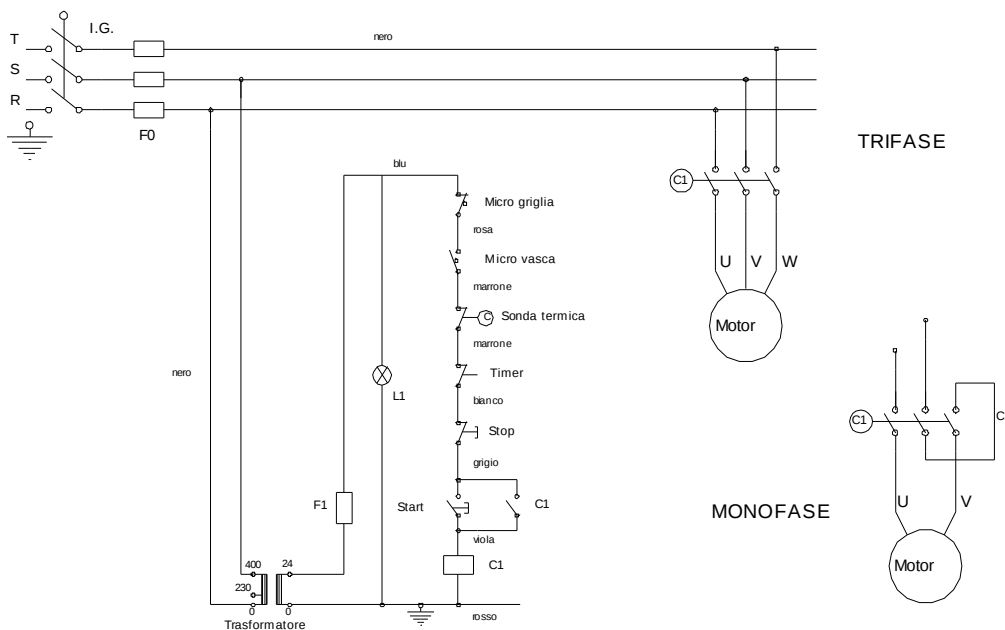

# Зип Общепит

vsezip.ru

+7(812)987-08-81

FUNCTIONING ANOMALIES	POSSIBLE CAUSES	REPAIRS
When turning switch into position 1 the warning lamp does not light.	1) The plug or the wires are not correctly connected. 2) The warning light is burnt.	1) Check right connection. 2) Replace the light.
When pressing start button the machine does not start.	1) Timer is not set or it's damaged. 2) The safety grid is lifted. 3) The bowl is not in the correct position. 4) The safety microswitches are damaged.	1) Set time again or turn the handle on the ON position. Press START button. If the anomaly is still present replace the timer. 2) Turn it completely close again and block it. 3) Check the position. 4) Replace the microswitches.
Small intermittent noise.	1) No grease in the transmission gears..	1) Grease as indicated in the lubricating sketch..
Continuous noise .	1) Check roller bearings.	1) Replace the bearings.
Hard speed change.	1) Leak of lubrication . 2) The shock absorber is broken or the lever is blocked.	1) Grease as indicated in the sketch. 2) Replace the shock absorber or the spring.
It is impossible to change speed.	1) The variable pulley is blocked. 2) The belt is worn out.	1) Check if there are mechanical problems that block the pulley. 2) Replace the belt.
The tool does not do its normal revolution on the tool shaft.	1) The entrainment pin is broken.	1) Replace the pin..



Зип Ощепит

vsezip.ru

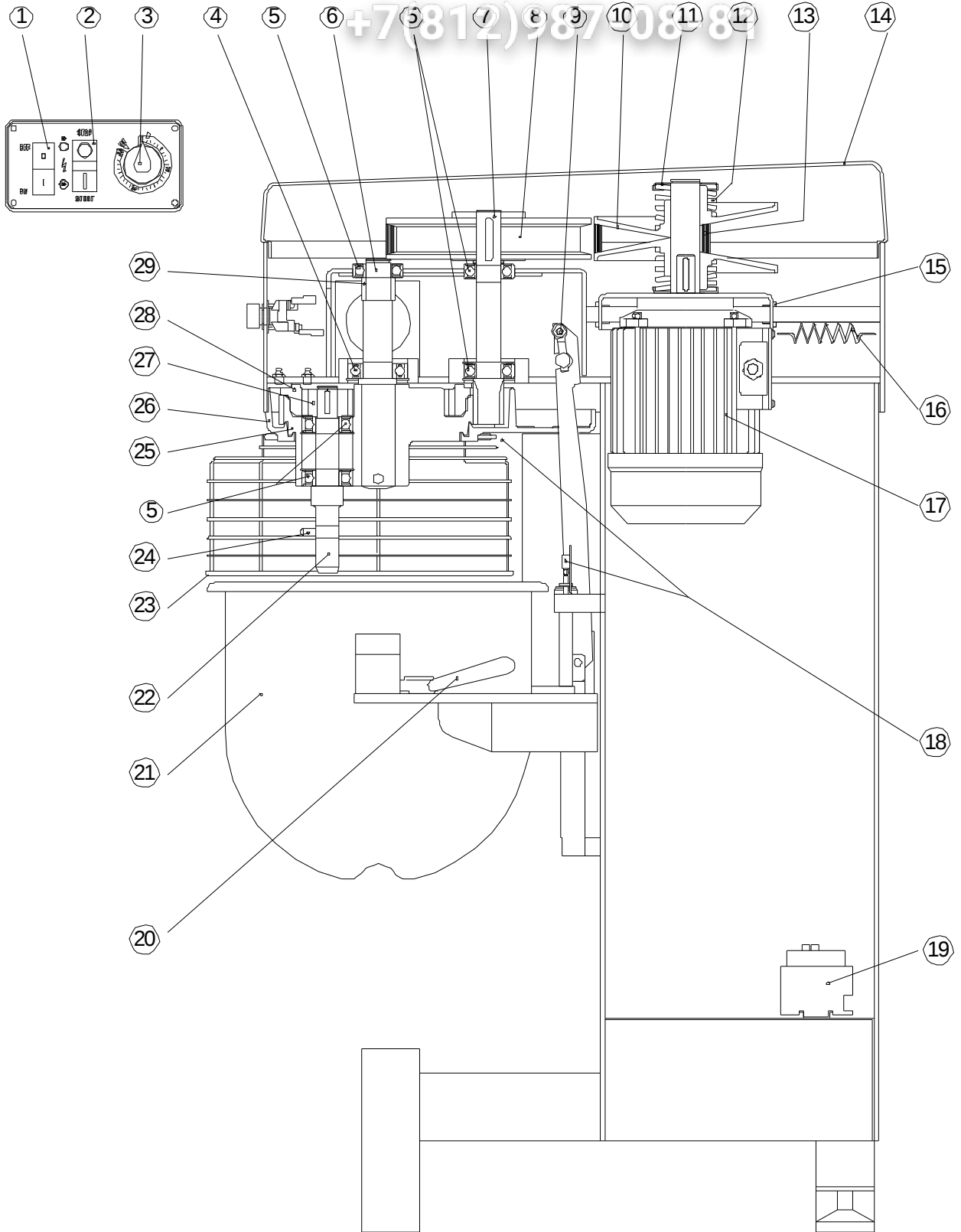

Зип Ощепит

vsezip.ru

+7(812)987-08-81

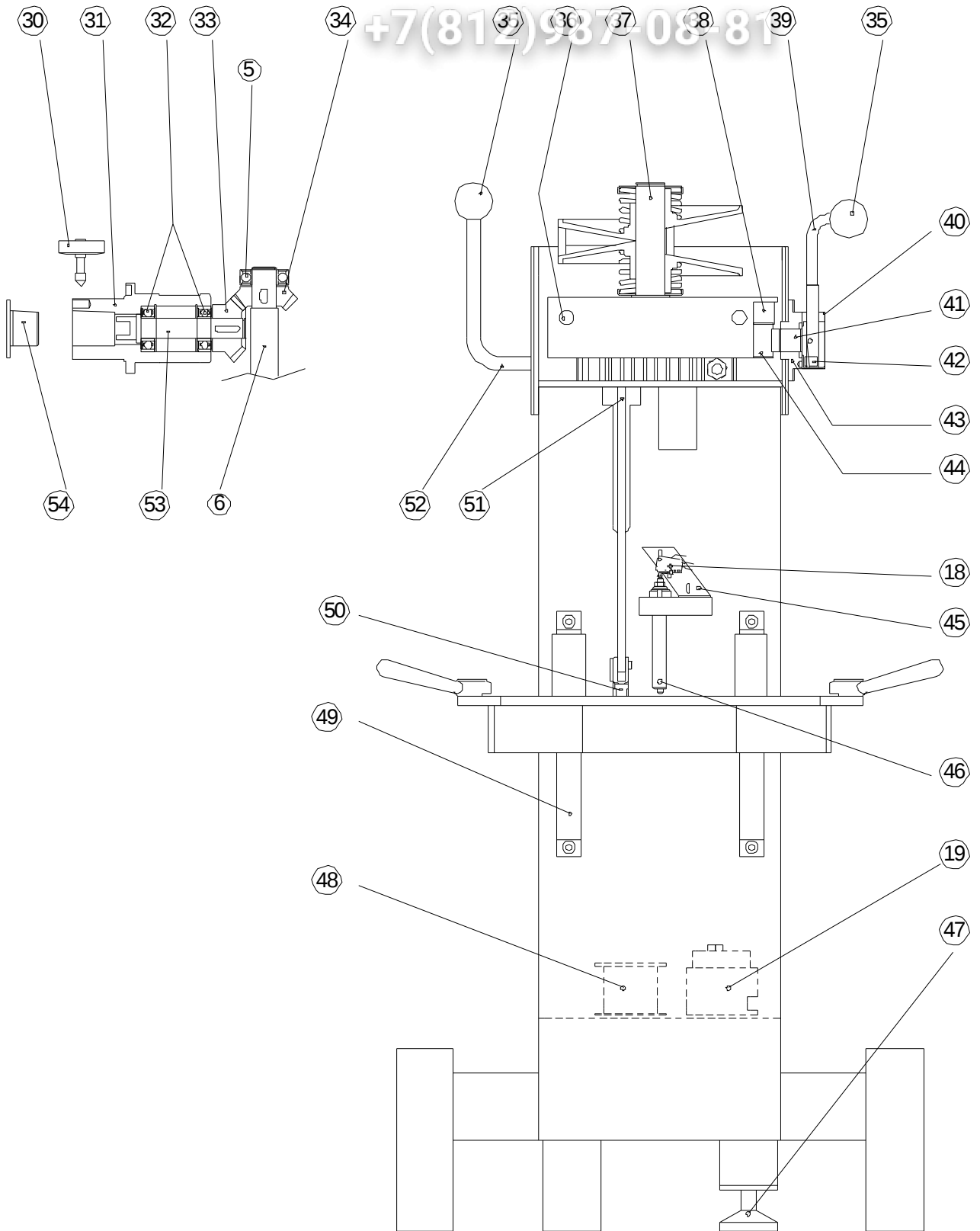

## SPARE PARTS LIST FOR PLANETARY MIXER BM30

N° RIF.	N° CODE	DESCRIPTION	QUANTITY
01	25003045	Three phase switch + protection 25003047	1
	25003046	Single phase switch + protection 25003047	
02	25009058	Square button QT011	1
03	25007039	Timer + Knob 25007038	1
04	13000017	Ball bearing 6206 2RS 30-62-16	1
05	13000016	Ball bearing 6205 2RS 25-52-15	5
06	01097011	Planetary shaft	1
07	01097007	Return shaft	1
08	01097006	Drive pulley	1
09	23010111	Eye tie rod M8x40	2
10	01097004	Variator half pulley	2
11	01097089	Entrainment cover	2
12	08097021	Variable pulley's spring	2
13	01097080	Variator belt 31x8x1000	1
14	03097046	Upper cover	1
15	15000003	Journal box 15x20x16	4
16	08097002	Motor chair's spring	1
17	11000701	Three phase motor 400V 50Hz gr.80 0,95Kw	1
	11000601	Single phase motor 230V 50Hz gr.80 0,75Kw	1
18	25001301	Microswitch +lever 25001302	1
19	25005108	Remote control switch 3TF2010-3AC2 24V	1
20	01098108	Bowl blocking handle	2
21	04161001	Bowl	1
22	01097015	Tool shaft	1
23	05097029	Protection grid	1
24	01098095	Tool shaft pin	1
25	01097009	Planetary	1
26	01097019	Gears protection cover	1
27	01097013	Planetary pinion	1
28	01097012	Internal toothed crown	1
29	01097161	Planetary shaft spacer	1
30	01097157	Little wheel for reducer	1
31	01097017	Reducer support	1
32	13000015	Ball bearing 6204 2RS 20-47-14	2
33	01097047	Bevel gear pair for reducer	1
34	01097016	Bevel gear for reducer	1
35	14002203	Knob PB/41 M8	2
36	01097118	Motor chair drive bar	2
37	01097120	Variable pulley shaft	1
38	01097038	Rack pole	1
39	01098038	Speed selecting lever	1
40	01098041	Closure cover	1
41	01097036	Speed pin	1
42	08098055	Handle spring	1
43	01097057	Speed lever support	1
44	01097038	Rack pole	1
45	02047046	Micro square	1

**SPARE PARTS LIST FOR PLANETARY MIXER BM30**

N° RIF.	N° CODE	DESCRIPTION	QUANTITY
46	01095073	Bowl blocking tube	1
47	14002822	Small foot M16 98/6364	1
48	25008001	Transformer 10VA 0/230/440 – 0/24	1
49	01097024	Bowl lifting drive bar	2
50	23010201	Fork M8 + 23001301 clip for fork M8	1
51	01161004	Bowl lifting tension rod	1
52	01097022	Bowl lifting lever	1
53	01097018	Shaft for Hobert attach	1
54	01097148	Reducer cap	1

**SPARE PARTS LIST FOR PLANETARY MIXER BM30  
(2 YEARS OPERATION)**

N° RIF.	N° CODE	DESCRIPTION	QUANTITY
01	25003045	Three phase switch + protection 25003047	1
	25003046	Single phase switch + protection 25003047	
02	25009058	Square button QT011	2
03	25007039	Timer + Knob 25007038	1
04	13000017	Ball bearing 6206 2RS 30-62-16	1
05	13000016	Ball bearing 6205 2RS 25-52-15	5
13	01097080	Variator belt 31x8x1000	1
18	25001323	Microswitch +lever 25001302	2
19	25005108	Remote control switch 3TF2010-3AC2 24V	1
24	01098095	Tool shaft pin	1
48	25008001	Transformer 10VA 0/230/440 – 0/24	1