

Зип Общепит

DESPIECE TECNICO

vsezip.ru

+7(812)987-08-81

**Frytop
Fry-Tops
Grillades
Griddleplatten
Frytop**

GAMA 700

Modelos:

**FTG-705
FTG-705 V
FTG-710
FTG-710 V
FTE-705
FTE-710**

Septiembre 2004 September



Fagor Industrial

Зип-Общепит

vsezip.ru

+7(812)987-08-81

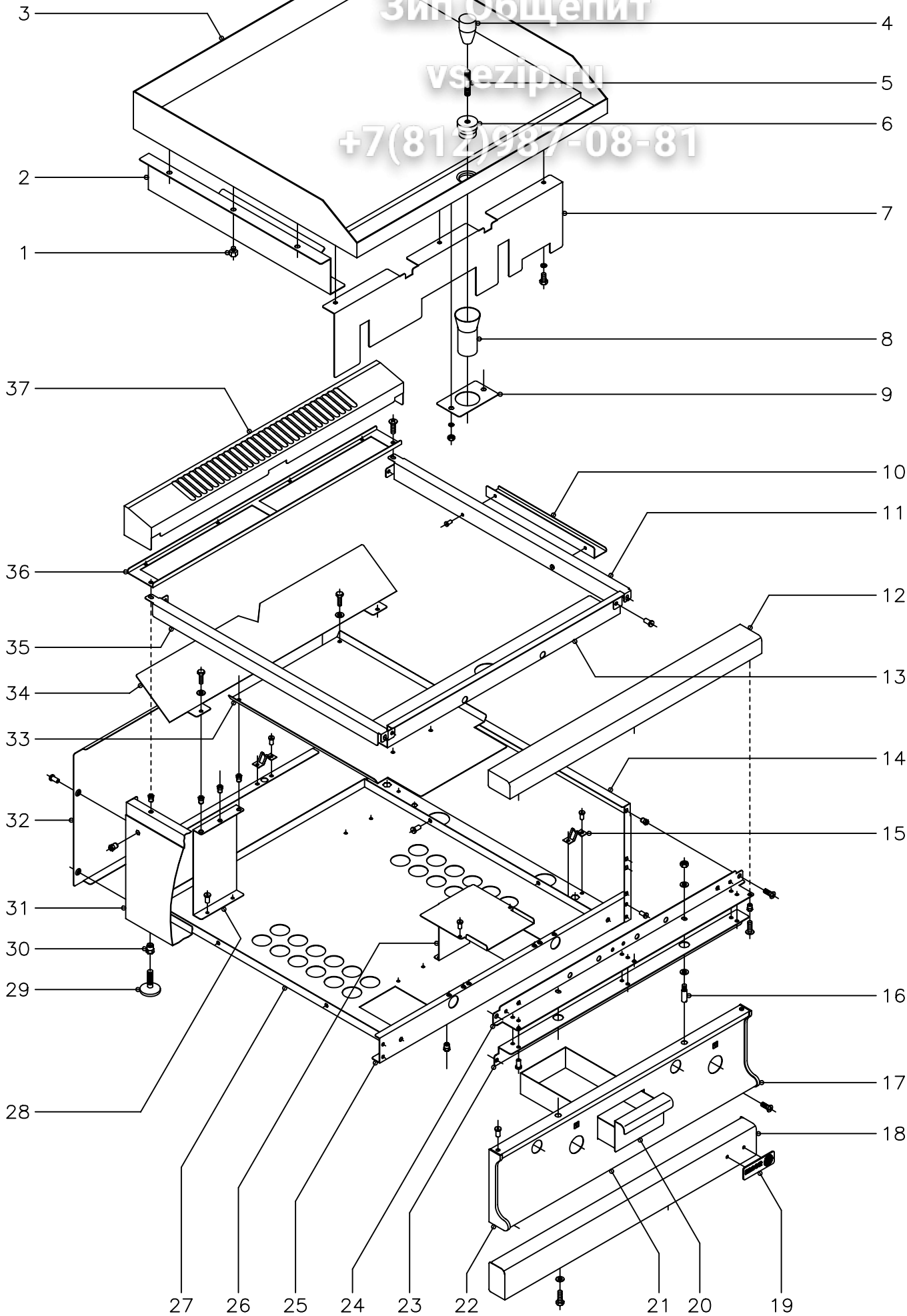

N plano C-1575	Firma 	Fecha 9-2004	Aparato MUEBLE FRY-TOP FTG-705, FTG-710	Lamina 1	Fagor Industrial S.Coop. FAGOR Onate
-------------------	-----------	-----------------	---	-------------	--

Зип Общепит

vsezip.ru

+7(812)987-08-81

MOD.		FRI-TOP	ZONA	MUEBLE			
ITEM	CODIGO	DENOMINACION	TEXTO	FTG-705	FTG-710	FTG-705 V	FTG-710 V
1	R615412	Apoyo lateral		6	6	6	6
2	R782612	Protector lateral izquierdo		1	-	1	-
s/n	R782609	Protector lateral derecho		1	-	1	-
2	R792620	Protector lateral		-	2	-	2
3	R785435	Plancha Lisa 705		1	-	1	-
3	R795416	Plancha Lisa 710		-	1	-	1
3	R785440	Plancha Lisa Cromoduro 705		1	-	-	-
3	R795422	Plancha Lisa Cromoduro 710		-	1	-	-
3	R785439	Plancha Rayada 705		1	-	1	-
3	R795420	Plancha Rayada 710		-	1	-	1
3	R795418	Plancha Lisa + Rayada		-	1	-	1
4	S116122	Mando pomo		1	1	-	-
5	R619913	Alargadera		1	1	-	-
6	R619912	Rebosadero-tapon		1	1	-	-
7	R782610	Protector frontal 705		1	-	1	-
7	R792623	Protector frontal 710		-	1	-	1
	Q262040	Arandela muelle A-6		2	3	2	3
	Q012041	Tornillo exagonal M-6x10		2	3	2	3
8	R795006	Tubo desagüe		1	1	1	1
9	R152607	Soporte tubo desagüe		1	1	1	1
	Q262040	Arandela muelle A-6		2	2	2	2
	Q162040	Tuerca exagonal M-6		2	2	2	2
10	R792605	Tirante lateral		2	2	2	2
	Q419005	Remache tubular Ø4x8		4	4	4	4
11	R792806	Lateral derecho de mesa		1	1	1	1
12	X315400	Anterior de mesa 705		1	-	1	-
12	U745407	Anterior de mesa 710		-	1	-	1
	Q221342	Remache exagonal M-5		2	2	2	2
	Q152004	Tornillo aplastado M-5x13		2	2	2	2

MOD.	FRI-TOP	ZONA	MUEBLE				
ITEM	CODIGO	DENOMINACION	TEXTO	FTG-705	FTG-710	FTG-705 V	FTG-710 V
13	R782606	Anterior interior de mesa 705		1	-	1	-
13	R792612	Anterior interior de mesa 710		-	1	-	1
	Q419005	Remache tubular Ø4x8		2	2	2	2
14	U732802	Panel lateral derecho		1	1	1	1
15	X010503	Muelle engancho piton		3	4	3	4
	Q419007	Remache tubular Ø3,2x6		6	8	6	8
16	Q151336	Tornillo soporte guia		2	2	2	2
	Q302022	Arandela plana Ø16xØ6x1,2		4	4	4	4
	Q162040	Tuerca exagonal M-6		2	2	2	2
17	U452804	Cantonera derecha portamandos		1	1	1	1
	Q419005	Remache tubular Ø4x8		2	2	2	2
18	R962800	Zocalo anterior 705		1	-	1	-
18	R972800	Zocalo anterior 710		-	1	-	1
	Q302022	Arandela plana Ø16xØ6x1,2		2	2	2	2
	Q012031	Tornillo exagonal M-5x10		2	2	2	2
19	U262806	Escudo FAGOR		1	1	1	1
	Q221023	Clip sujecion escudo		2	2	2	2
20	R792606	Caja recoge grasas		1	1	1	1
21	R782809	Panel portamandos 705		1	-	-	-
21	R792813	Panel portamandos 710		-	1	-	-
21	R782808	Panel portamandos 705 V		-	-	1	-
21	R792812	Panel portamandos 710 V		-	-	-	1
	Q152004	Tornillo aplastado M-5x13		2	2	2	2
22	U452805	Cantonera izquierda portamandos		1	1	1	1
	Q419005	Remache tubular Ø4x8		2	2	2	2
23	X312630	Refuerzo amarre mesa 705		1	-	1	-
23	U742620	Refuerzo amarre mesa 710		-	1	-	1
	Q419005	Remache tubular Ø4x8		4	6	4	6
	Q221342	Remache exagonal M-5		2	2	2	2

MOD.	FRI-TOP	ZONA	MUEBLE				
ITEM	CODIGO	DENOMINACION	TEXTO	FTG-705	FTG-710	FTG-705 V	FTG-710 V
	Q152004	Tornillo aplastado M-5x13		2	2	2	2
24	X312600	Escuadra amarre mesa 705		1	-	1	-
24	U742607	Escuadra amarre mesa 710		-	1	-	1
	Q221342	Remache exagonal M-5		2	2	2	2
	Q152004	Tornillo aplastado M-5x13		2	2	2	2
25	U722603	Escuadra anterior base bandejas		1	-	1	-
25	R982600	Escuadra anterior base bandejas		-	1	-	1
	Q419005	Remache tubular Ø4x8		4	4	4	4
26	R792609	Guia recoge grasas		1	1	1	1
	Q419005	Remache tubular Ø4x8		4	4	4	4
27	R782803	Base inferior 705		1	-	1	-
27	R792805	Base inferior 710		-	1	-	1
	Q419005	Remache tubular Ø4x8		4	4	4	4
28	R782600	Soporte quemador		1	3	1	3
	Q221342	Remache exagonal M-5		1	8	1	8
	Q419005	Remache tubular Ø4x8		2	6	2	6
29	Z200105	Pata regulable		4	4	4	4
30	Q221345	Remache exagonal M-10		4	4	4	4
31	U732801	Panel lateral izquierdo		1	1	1	1
32	U722803	Panel posterior 705		1	-	1	-
32	U732803	Panel posterior 710		-	1	-	1
	Q419005	Remache tubular Ø4x8		4	4	4	4
33	R792621	Separador central		-	1	-	1
	Q012031	Tornillo exagonal M-5x10		-	4	-	4
	Q302022	Arandela plana Ø16xØ6x1,2		-	4	-	4
34	R782611	Protector posterior 705		1	-	1	-
34	R792622	Protector posterior 710		-	1	-	1
	Q012031	Tornillo exagonal M-5x10		2	2	2	2
	Q302022	Arandela plana Ø16xØ6x1,2		2	2	2	2

Зип Общепит

vsezip.ru

+7(812)987-08-81

MOD.		FRI-TOP	ZONA	MUEBLE				
ITEM	CODIGO	DENOMINACION	TEXTO	FTG-705	FTG-710	FTG-705 V	FTG-710 V	
35	R792804	Lateral izquierdo de mesa		1	1	1	1	
36	R782601	Posterior interior de mesa 705		1	-	1	-	
36	R792610	Posterior interior de mesa 710		-	1	-	1	
	Q012031	Tornillo exagonal M-5x10		2	2	2	2	
	Q221342	Remache exagonal M-5		2	2	2	2	
37	X315425	Embelledor de chimenea 705		1	-	1	-	
37	U745425	Embelledor de chimenea 710		-	1	-	1	

Зип Общепит

vsezip.ru

+7(812)987-08-81

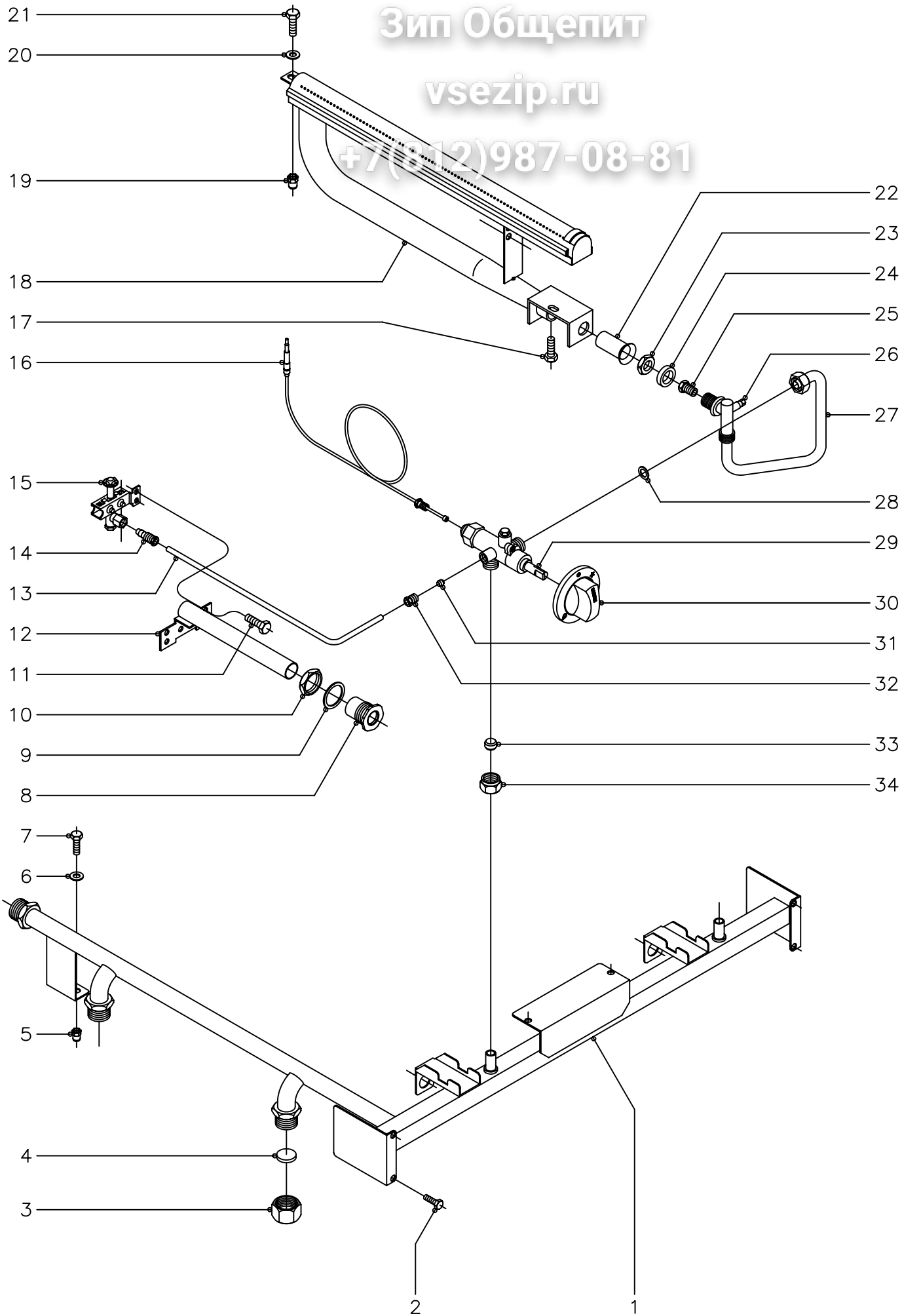

N plano C-1576	Firma 	Fecha 9-2004	Aparato PARTE FUNCIONAL (GRIFO CAL-3200) FRY-TOP FTG-705V, FTG-710V	Lamina 2	Fagor Industrial S.Coop. FAGOR Onate
-------------------	-----------	-----------------	---	-------------	--

Зип Общепит

vsezip.ru

+7(812)987-08-81

MOD.		FRI-TOP A GAS (V)		ZONA	PARTE FUNCIONAL (Grifo CAL-3			
ITEM	CODIGO	DENOMINACION	TEXTO	FTG-705 V	FTG-710 V			
1	R785024	Tube distribuidor general 705V		1	-			
1	R795032	Tube distribuidor general 710V		-	1			
2	Q012031	Tornillo exagonal M-5x10		4	4			
3	U635008	Tuerca ciega 3/4"		2	2			
4	Q306051	Arandela tapon Ø23,5x3		2	2			
5	Q221342	Remache exagonal M-5		2	2			
6	Q302022	Arandela plana Ø16xØ6x1,2		2	2			
7	Q012031	Tornillo exagonal M-5x10		2	2			
8	S112804	Embellecedor tubo de encendido		1	2			
9	Q306027	Arandela junta Ø33,8xØ27x1,5		1	2			
10	Q221324	Tuerca exagonal 3/4"		1	2			
11	Q012031	Tornillo exagonal M-5x10		2	4			
12	R165011	Tube encendido completo		1	2			
13	R785027	Tube piloto 705V		1	-			
13	R795037	Tube piloto 710V		-	2			
14	U134323	Racord con bicono Ø6		1	2			
15	U322118	Piloto completo		1	2			
	U442138	Inyector piloto Ø 0,25 (B.P.yG.V.)		1	2			
	U442137	Inyector piloto Ø 0,40 (Gas Natural)		1	2			
16	U222130	Termopar L=600		1	2			
17	Q012032	Tornillo exagonal M-5x15		1	2			
18	R795700	Quemador		1	2			
19	Q221342	Remache exagonal M-5		1	2			
20	Q302022	Arandela plana Ø16xØ6x1,2		1	2			
21	Q012031	Tornillo exagonal M-5x10		1	2			
22	U325707	Regulador de aire		1	2			
23	Q223019	Tuerca exagonal 3/8"		1	2			
24	Q301323	Arandela Ø25xØ17x6		1	2			
25	R422400	Tobera quemador Ø1,25 (B.P.)		1	2			

Зип Общепит

vsezip.ru

+7(812)987-08-81

MOD.		FRI-TOP A GAS (V)		ZONA	PARTE FUNCIONAL (Grifo CAL-3				
ITEM	CODIGO	DENOMINACION	TEXTO	FTG-705 V	FTG-710 V				
25	9429500	Tobera quemador Ø1,90 (G.N.)		1	2				
26	Q153002	Tornillo tapon (toma presion)		1	2				
27	R785026	Conjunto conduccion quemador		1	-				
27	R795035	Conjunto conduccion quemador		-	1				
28	Q306055	Arandela junta Ø16xØ10,3x1		1	2				
29	U249402	Grifo CAL-3200 (min. 0,9)		1	2				
30	U542101	Boton de mando Ø 10		1	2				
31	X205028	Bicono Ø 6		1	2				
32	U195009	Manguito empalme		1	2				
33	U055043	Bicono Ø 12		1	2				
34	Q221336	Tuerca M-18x1,5 (p/tubo Ø12)		1	2				

Зип Общепит

vsezip.ru

+7(812)987-08-81

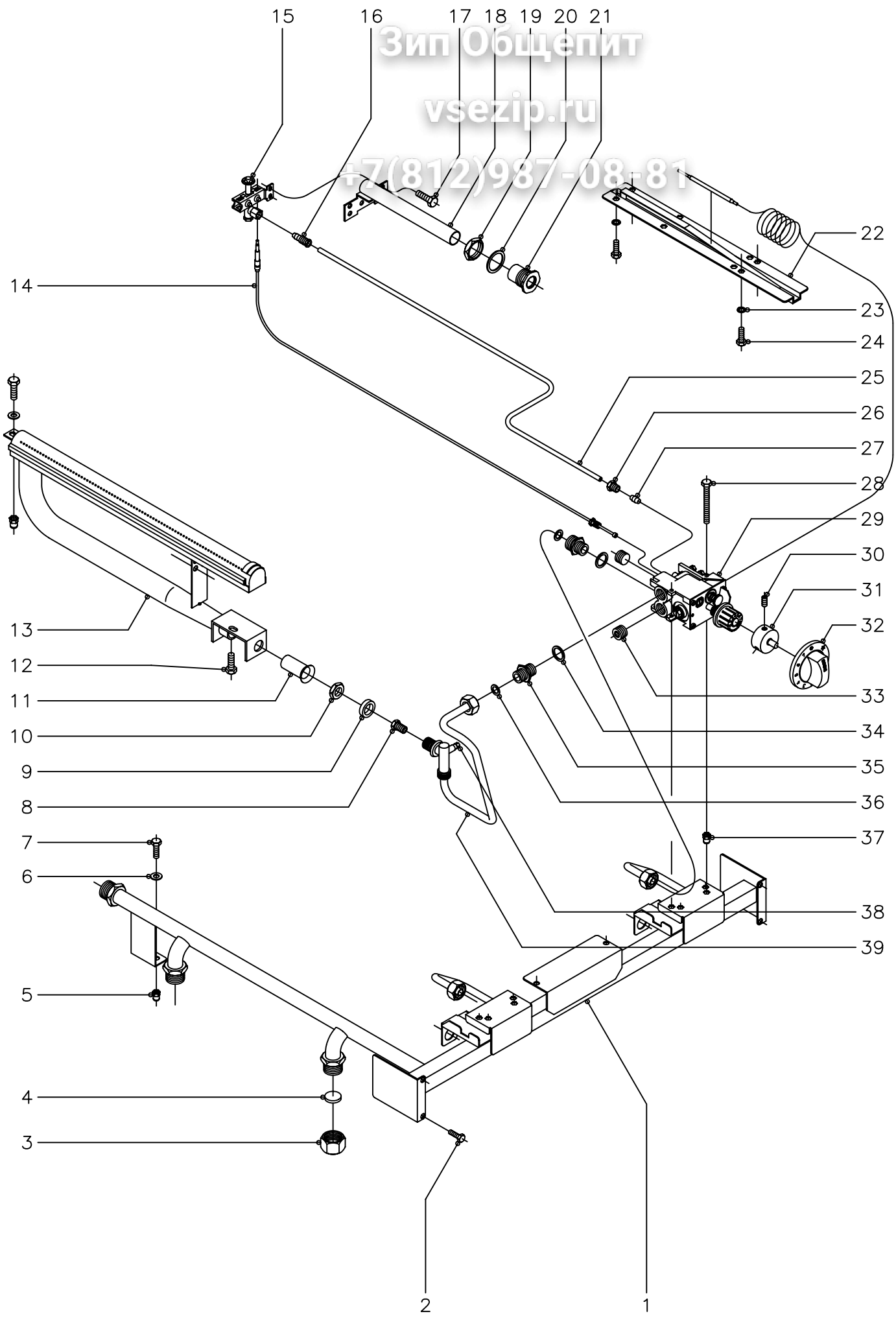

N plano C-1577	Firma 	Fecha 9-2004	Aparato PARTE FUNCIONAL (VALVULA EUROSIT) FRY-TOP FTG-705, FTG-710	Lamina 3	Fagor Industrial S.Coop. FAGOR Onate
-------------------	-----------	-----------------	--	-------------	--

Зип Общепит

vsezip.ru

+7(812)987-08-81

MOD.		FRI-TOP A GAS	ZONA	PARTE FUNCIONAL (Valvula Euro				
ITEM	CODIGO	DENOMINACION	TEXTO	FTG-705	FTG-710			
1	R785030	Distribuidor general completo 705		1	-			
1	R795043	Distribuidor general completo 710		-	1			
2	Q012031	Tornillo exagonal M-5x10		4	4			
3	U635008	Tuerca ciega 3/4"		2	2			
4	Q306051	Arandela tapon Ø23,5x3		2	2			
5	Q221342	Remache exagonal M-5		2	2			
6	Q302022	Arandela plana Ø16xØ6x1,2		2	2			
7	Q012031	Tornillo exagonal M-5x10		2	2			
8	R422400	Tobera quemador Ø1,25 (B.P.)		1	2			
8	9429500	Tobera quemador Ø1,90 (G.N.)		1	2			
8	R792400	Tobera quemador Ø4,00 (G.V.)		1	2			
9	Q301323	Arandela Ø25xØ17x6		1	2			
10	Q223019	Tuerca exagonal 3/8"		1	2			
11	U325707	Regulador de aire		1	2			
12	Q012032	Tornillo exagonal M-5x15		1	2			
13	R795700	Quemador		1	2			
	Q221342	Remache exagonal M-5		1	2			
	Q302022	Arandela plana Ø16xØ6x1,2		1	2			
	Q012031	Tornillo exagonal M-5x10		1	2			
14	U222130	Termopar L=600		1	2			
15	U322118	Piloto completo		1	-			
	U442138	Inyector piloto Ø0,25 (B.P. y G.V.)		1	2			
	U442137	Inyector piloto Ø0,40 (G.N.)		1	2			
16	U134323	Racord con bicono Ø6		1	2			
17	Q012031	Tornillo exagonal M-5x10		2	4			
18	R165011	Tubo de encendido		1	2			
19	Q221324	Tuerca exagonal 3/4"		1	2			
20	Q306027	Arandela junta Ø33,8xØ27x1,5		1	2			
21	S112804	Embellecedor tubo de encendido		1	2			

Зип Общепит

vsezip.ru

+7(812)987-08-81

MOD.	FRI-TOP A GAS		ZONA	PARTE FUNCIONAL (Valvula Euro				
ITEM	CODIGO	DENOMINACION	TEXTO	FTG-705	FTG-710			
22	R162630	Conjunto soporte bulbo		1	2			
23	Q262040	Arandela muelle A-6		4	8			
24	Q012041	Tornillo exagonal M-6x10		4	8			
25	R785034	Tubo piloto 705		1	-			
25	R795045	Tubo piloto 710		-	2			
26	U195009	Manguito empalme		1	2			
27	X205028	Bicono Ø 6		1	2			
28	Q011338	Tornillo exagonal M-5x60		2	4			
29	T982100	Valvula eurosit 630		1	2			
30	Q131502	Varilla roscada M-5x6		3	6			
31	U842100	Suplemento para Eurosit		1	2			
32	U842102	Boton de mando Ø8		1	2			
33	T982102	Tapon 3/8"		2	4			
34	Q306058	Arandela junta Ø23,5xØ17,60x1,5		2	4			
35	R155068	Manguito doble 3/8"		2	4			
36	Q306062	Arandela junta Ø13,90xØ10,33x1		1	2			
37	Q221342	Remache exagonal M-5		2	4			
38	Q153002	Tornillo tapon (Toma presion)		1	2			
39	R785032	Conduccion a quemador 705		1	-			
39	R795041	Conduccion a quemador 710		-	2			

Зип Ощепит

vsezip.ru

+7(812)987-08-81

	MOD.	FRI-TOP	ZONA	VARIOS				
ITEM	CODIGO	DENOMINACION	TEXTO	FTG-705	FTG-710	FTG-705 V	FTG-710 V	FTG-705 A
	R166502	Folleto de instrucciones		1	1	1	1	-
	R166517	Folleto de instrucciones		-	-	-	-	1
	R636500	Rasqueta Martor		1	1	-	-	-

MOD.	FRI-TOP	ZONA	PIEZAS ESPECIFICAS PARA LOS DISTIN					
ITEM	CODIGO	DENOMINACION	TEXTO	FTG-705 V	FTG-710 V	FTG-705	FTG-710	FTG-705 A
		<u>BUTANO - PROPANO</u>						
25	R422400	Tobera quemador Ø1,25		1	2	-	-	-
8	R422400	Tobera quemador Ø1,25		-	-	1	2	-
8	U052402	Tobera quemador Ø1,30		-	-	-	-	1
15	U442138	Inyector piloto Ø0,25		1	2	1	2	1
s/n	U136501	Indicador (Butano - Propano)		1	1	1	1	1
		<u>GAS NATURAL</u>						
25	9429500	Tobera quemador Ø1,90		1	2	-	-	-
8	9429500	Tobera quemador Ø1,90		-	-	1	2	-
8	U134401	Tobera quemador Ø2,20		-	-	-	-	1
15	U442137	Inyector piloto Ø0,40		1	2	1	2	1
s/n	U134402	Indicador (Gas Natural)		1	1	1	1	1
		<u>GAS VILLA</u>						
25	R742400	Tobera quemador Ø3,60		1	2	-	-	-
15	U442138	Inyector piloto Ø0,25		1	2	-	-	-
s/n	U134310	Indicador (Gas Villa)		1	1	-	-	-

Зип Общепит

vsezip.ru

+7(812)987-08-81

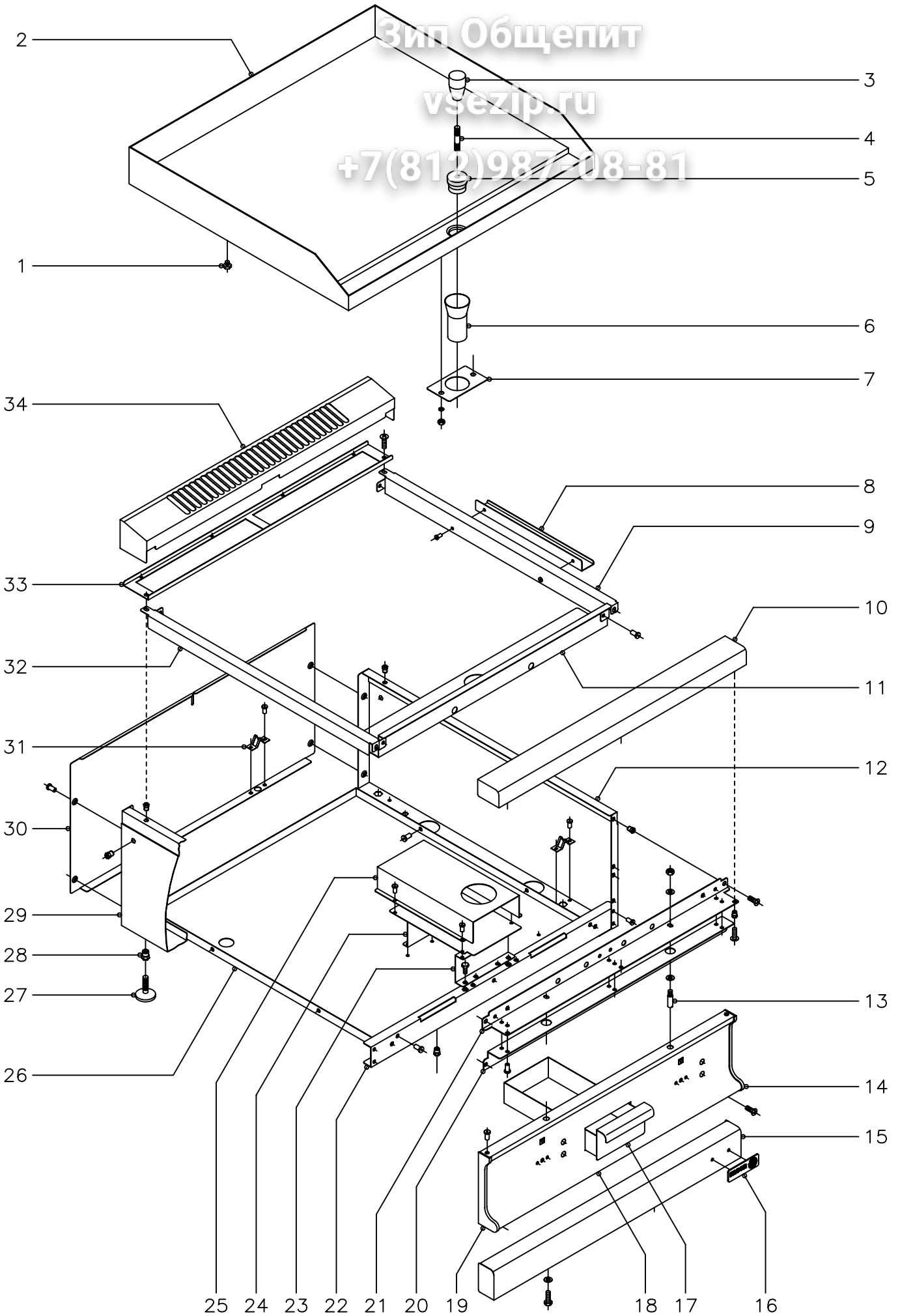

N plano C-1578	Firma 	Fecha 9-2004	Aparato FRY-TOP FTE-705, FTE-710	MUEBLE	Lamina 4	Fagor Industrial S.Coop. FAGOR Onate
-------------------	-----------	-----------------	-------------------------------------	--------	-------------	--

Зип Общепит

vsezip.ru

+7(812)987-08-81

MOD.		FRI-TOP	ZONA	MUEBLE				
ITEM	CODIGO	DENOMINACION	TEXTO	FTE-705	FTE-710			
1	R165414	Apoyo lateral		6	6			
2	R885416	Plancha Lisa 705		1	-			
2	R895416	Plancha Lisa 710		-	1			
2	R885420	Plancha Lisa Cromoduro 705		1	-			
2	R895422	Plancha Lisa Cromoduro 710		-	1			
2	R885418	Plancha Rayada 705		1	-			
2	R895420	Plancha Rayada 710		-	1			
2	R895418	Plancha Lisa + Rayada		-	1			
3	S116122	Mando pomo		1	1			
4	R619913	Alargadera		1	1			
5	R619912	Rebosadero-tapon		1	1			
6	R895431	Tubo desagüe		1	1			
7	R152607	Soporte tubo desagüe		1	1			
	Q262040	Arandela muelle A-6		2	2			
	Q162040	Tuerca exagonal M-6		2	2			
8	R792605	Tirante lateral		2	2			
	Q419005	Remache tubular Ø4x8		4	4			
9	R792806	Lateral derecho de mesa		1	1			
10	X315400	Anterior de mesa 705		1	-			
10	U745407	Anterior de mesa 710		-	1			
	Q221342	Remache exagonal M-5		2	2			
	Q152004	Tornillo aplastado M-5x13		2	2			
11	R782606	Anterior interior de mesa 705		1	-			
11	R792612	Anterior interior de mesa 710		-	1			
	Q419005	Remache tubular Ø4x8		2	2			
12	U732802	Panel lateral derecho		1	1			
13	Q151336	Tornillo soporte guia		2	2			
	Q302022	Arandela plana Ø16xØ6x1,2		4	4			
	Q162040	Tuerca exagonal M-6		2	2			

MOD.	FRI-TOP	ZONA	MUEBLE					
ITEM	CODIGO	DENOMINACION	TEXTO	FTE-705	FTE-710			
14	U452804	Cantонера derecha portamandos		1	1			
	Q419005	Remache tubular Ø4x8		2	2			
15	R962800	Zocalo anterior 705		1	-			
15	R972800	Zocalo anterior 710		-	1			
	Q302022	Arandela plana Ø16xØ6x1,2		2	2			
	Q012031	Tornillo exagonal M-5x10		2	2			
16	U262806	Escudo FAGOR		1	1			
	Q221023	Clip sujecion escudo		2	2			
17	R792606	Caja recoge grasas		1	1			
18	R882800	Panel portamandos 705		1	-			
18	R892800	Panel portamandos 710		-	1			
	Q152004	Tornillo aplastado M-5x13		2	2			
19	U452805	Cantонера izquierda portamandos		1	1			
	Q419005	Remache tubular Ø4x8		2	2			
20	X312630	Refuerzo amarre mesa 705		1	-			
20	U742620	Refuerzo amarre mesa 710		-	1			
	Q419005	Remache tubular Ø4x8		4	6			
	Q221342	Remache exagonal M-5		2	2			
	Q152004	Tornillo aplastado M-5x13		2	2			
21	X312600	Escuadra amarre mesa 705		1	-			
21	U742607	Escuadra amarre mesa 710		-	1			
	Q221342	Remache exagonal M-5		2	2			
	Q152004	Tornillo aplastado M-5x13		2	2			
22	U722603	Escuadra anterior base bandejas		1	-			
22	U732601	Escuadra anterior base bandejas		-	1			
	Q419005	Remache tubular Ø4x8		4	4			
23	R892603	Soporte guia recoge grasas		1	1			
	Q221342	Remache exagonal M-5		2	2			
	Q012031	Tornillo exagonal M-5x10		2	2			

Зип Общепит

vsezip.ru

+7(812)987-08-81

MOD.		FRI-TOP	ZONA	MUEBLE				
ITEM	CODIGO	DENOMINACION	TEXTO	FTE-705	FTE-710			
24	R892604	Guia recoge grasas		1	1			
	Q419005	Remache tubular Ø4x8		2	2			
25	R892605	Cubierta recoge grasas		1	1			
	Q419005	Remache tubular Ø4x8		4	4			
26	R962601	Base inferior 705		1	-			
26	R972600	Base inferior 710		-	1			
	Q419005	Remache tubular Ø4x8		4	4			
27	Z200105	Pata regulable		4	4			
28	Q221345	Remache exagonal M-10		4	4			
29	U732801	Panel lateral izquierdo		1	1			
30	U722803	Panel posterior 705		1	-			
30	U732803	Panel posterior 710		-	1			
	Q419005	Remache tubular Ø4x8		4	4			
31	X010503	Muelle enganche piton		3	4			
	Q419007	Remache tubular Ø3,2x6		6	8			
32	R792804	Lateral izquierdo de mesa		1	1			
33	R782601	Posterior interior de mesa 705		1	-			
33	R792610	Posterior interior de mesa 710		-	1			
	Q012031	Tornillo exagonal M-5x10		2	2			
	Q221342	Remache exagonal M-5		2	2			
34	X315425	Embellecedor de chimenea 705		1	-			
34	U745425	Embellecedor de chimenea 710		-	1			

Зип Общепит

vsezip.ru

+7(812)987-08-81

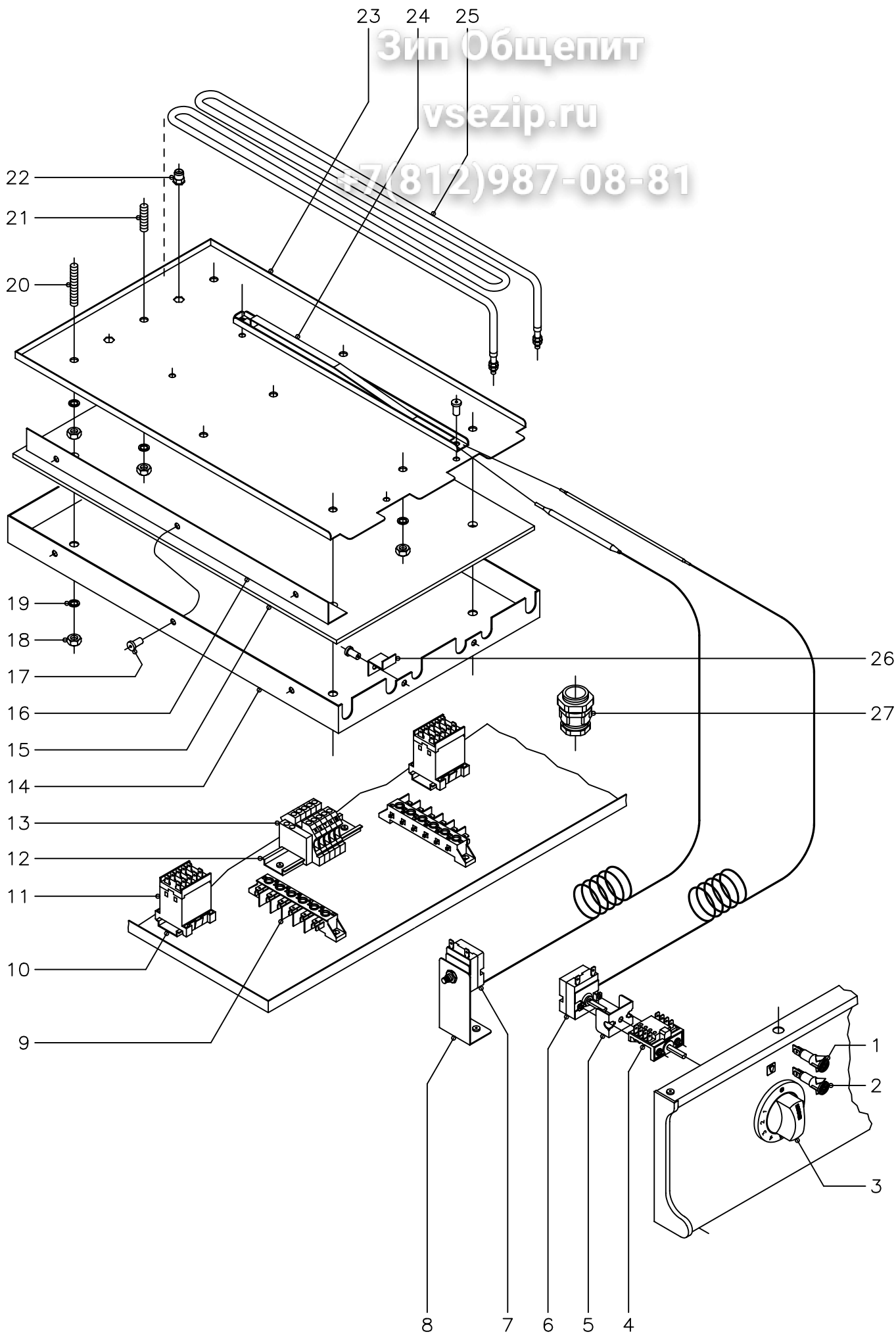

N plano C-1579	Firma 	Fecha 9-2004	Aparato FRY-TOP FTE-705, FTE-710	PARTE FUNCIONAL ELECTRICA	Lamina 5	Fagor Industrial S.Coop. FAGOR Orate
-------------------	-----------	-----------------	-------------------------------------	---------------------------	-------------	--

MOD.	FRI-TOP	ZONA	PARTE FUNCIONAL ELECTRIC					
ITEM	CODIGO	DENOMINACION	TEXTO	FTE-705	FTE-710			
1	R693055	Piloto verde		1	2			
2	R693056	Piloto ambar		1	2			
3	U673017	Boton de mando Ø6		1	2			
	Q281000	Anillo de compresion para boton		1	2			
4	X163007	Conmutador acople termostato		1	2			
5	X313001	"U" soporte termostato		1	2			
6	X153000	Termostato 50 - 310° C.		1	2			
7	R612103	Termostato limitador		1	2			
8	R572607	Soporte limitador		1	2			
9	R253044	Regleta		1	2			
10	Z123018	Guia contactor L=55		1	2			
11	Z213007	Contactador 3TF2010 - 3AL2		1	2			
12	R663055	Guia contactor L=120		-	1			
13	P453025	Borna fases 10 (gris)		-	3			
	Z263302	Borna neutro 10 (azul)		-	1			
	P453026	Borna tierra 10 (verde - amarillo)		-	1			
	Z263303	Tope final		-	1			
14	R882600	Cubierta resistencias 705		1	-			
14	R892600	Cubierta resistencias 710		-	2			
15	R885410	Aislante resistencias 705		1	-			
15	R895410	Aislante resistencias 710		-	2			
16	R892602	Fijacion lateral aislante		2	4			
17	Q419005	Remache tubular Ø4x8		6	12			
18	Q162050	Tuerca exagonal M-8		13	26			
19	Q262050	Arandela muelle A-8		13	26			
20	Q131557	Varilla roscada M-8x50		4	8			
21	Q131555	Varilla roscada M-8x30		5	10			
22	Q221343	Remache exagonal M-6		2	4			
23	R882602	Amarre resistencias 705		1	-			

Зип Общепит

vsezip.ru

+7(812)987-08-81

MOD.	FRI-TOP	ZONA	PARTE FUNCIONAL ELECTRIC						
ITEM	CODIGO	DENOMINACION	TEXTO	FTE-705	FTE-710				
23	R892606	Amarre resistencias 710		-	2				
24	R592630	Conjunto soporte bulbo		1	2				
	Q419005	Remache tubular Ø4x8		2	4				
25	R893000	Resistencia 1500 W., 230 V.		3	6				
26	U615409	Distanciador		1	2				
	Q419005	Remache tubular Ø4x8		1	2				
27	R013022	Prensaestopas		1	-				
27	R023013	Prensaestopas		-	1				

MOD.	FRI-TOP	ZONA	VARIOS					
ITEM	CODIGO	DENOMINACION	TEXTO	FTE-705	FTE-710			
	R596502	Folleto de instrucciones		1	1			
	R636500	Rasqueta Martor		1	1			
	R563000	Esquema electrico adhesivo		1	-			
	R573001	Esquema electrico adhesivo		-	1			
	R573005	Esquema electrico de montaje		1	1			
	R223000	Cableado portamandos		1	2			
	R223003	Cableado contactor a resistencias		1	2			
	R223002	Cableado regleta a contactor		1	2			
	R573003	Cable a limitador		1	2			
	R573002	Cableado regleta a bornas		-	2			
	X183008	Cableado regleta a contactor		-	2			

FTE-905 FTE-705

vsezip.ru

+7(812)987-08-81

NOTAS

- Las inscripciones resistirán sin modificación apreciable el frotamiento durante 15 seg. de un algodón impregnado en gasolina.

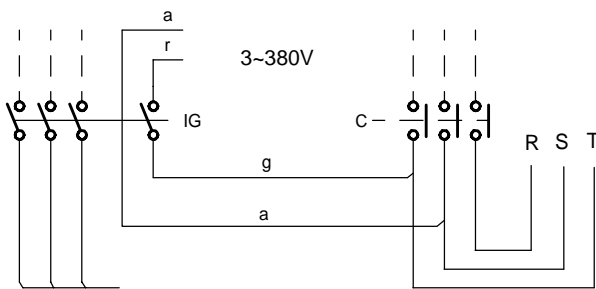
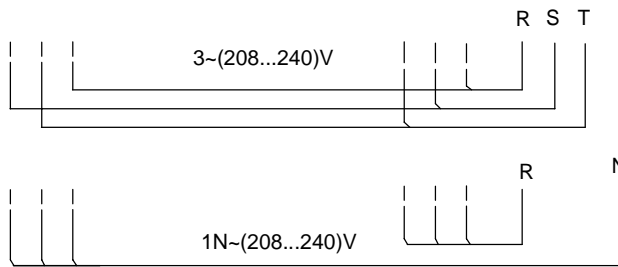
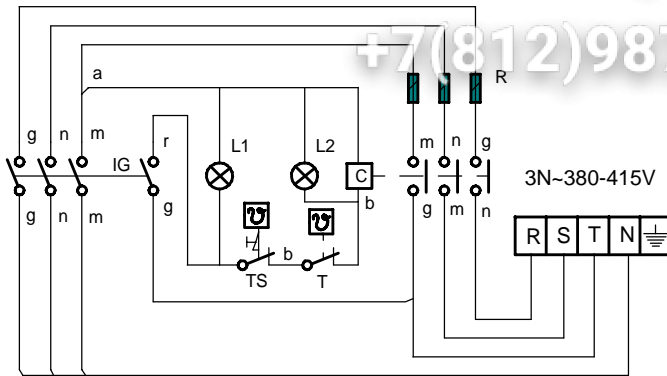

- IG: Interruptor general
- L1: Lámpara funcionamiento
- T: Termostato regulable (50-310°C)
- L2: Lámpara calentamiento
- C: Contactor de calentamiento
- R: Resistencias
- TS: Termostato seguridad (400°C)

- r = rojo-red-rouge
- m = marron-brown-marron
- g = gris-grey-gris
- n = negro-black-noir
- a = azul-blue-bleu
- b = blanco-white-blanc
- vi = violeta-violette-violet
- am/ve = amarillo/verde
yellow/green
jaune/vert

Esquema teorico adhesivo			R-563000		
Nº	Pieza	Cant.	Material	Nº Clasificacion	Acabado
Nº	Modificacion		Propuesta de	Fecha	Tolerancias generales
①	Introducir TS		Maillo	95-6-14	$\leq 5 \pm$: $50-100 \pm$: $5-25 \pm$: $> 100 \pm$ $25-50 \pm$: $\infty \pm$
②	Introducir FTE-705		Etxeberria	1-7-97	
③	Introducir G-700		Etxeberria	8-7-97	
	Firma	Fecha	 Fagor Industrial, Koop. Elk, Mugatua		Mecanizado superficial
Dibujado	JON	95-5-23			
Proyectado					
Comprobado	<i>Leto g</i>				
Escala	FRY-TOP				Plano numero HB-14936 -3
Plano hau ez daiteke erabil ez berrizta gure baimenitz gabe					Sustituye al N°
					Sustituido por

Зип Общепит

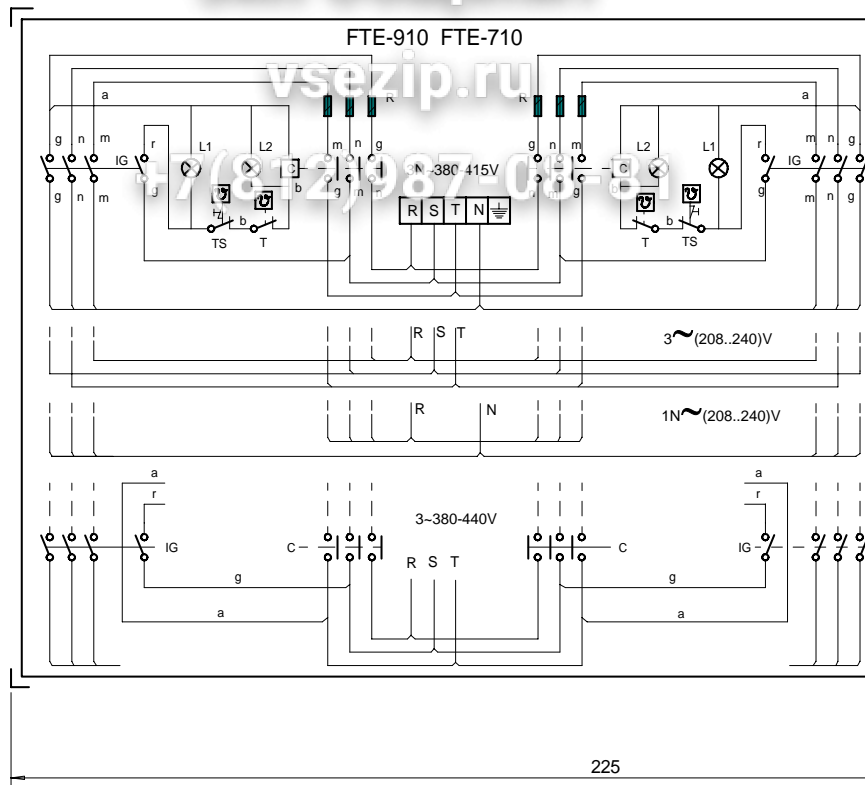

IG: Interruptor general
 L1: Lámpara funcionan
 T: Termos.regulable(50-
 L2: Lámpara calentami
 C: Contactor calentami
 R: Resistencias
 TS: Termos.seguridad(4

r = rojo-red-rouge
 m = marron-brown-ma
 g = gris-grey-gris
 n = negro-black-noir
 a = azul-blue-bleu
 b = blanco-white-blanc
 vi = violeta-violette-vio
 am/ve = amarillo/verde
 yellow/green
 jaune/vert

NOTA

- Las inscripciones resistirán sin modificación apreciable el frotamiento durante 15 seg.
 de un algodón impregnado en gasolina.

Esquema teorico adhesivo		
Nº	Pieza	
Nº	Modificacion	
①	Introducir TS	
2	Modific.general(pasar a fabric.interior)	
③	Introducir FTE-705	
④	Introducir G 700	
	Firma	Fecha
Dibujado	JON	95-5-23
Proyectado		
Comprobado	<i>Letouca</i>	
Escala	1/1	
Plano hau ez daitteke erabil ez berizta		

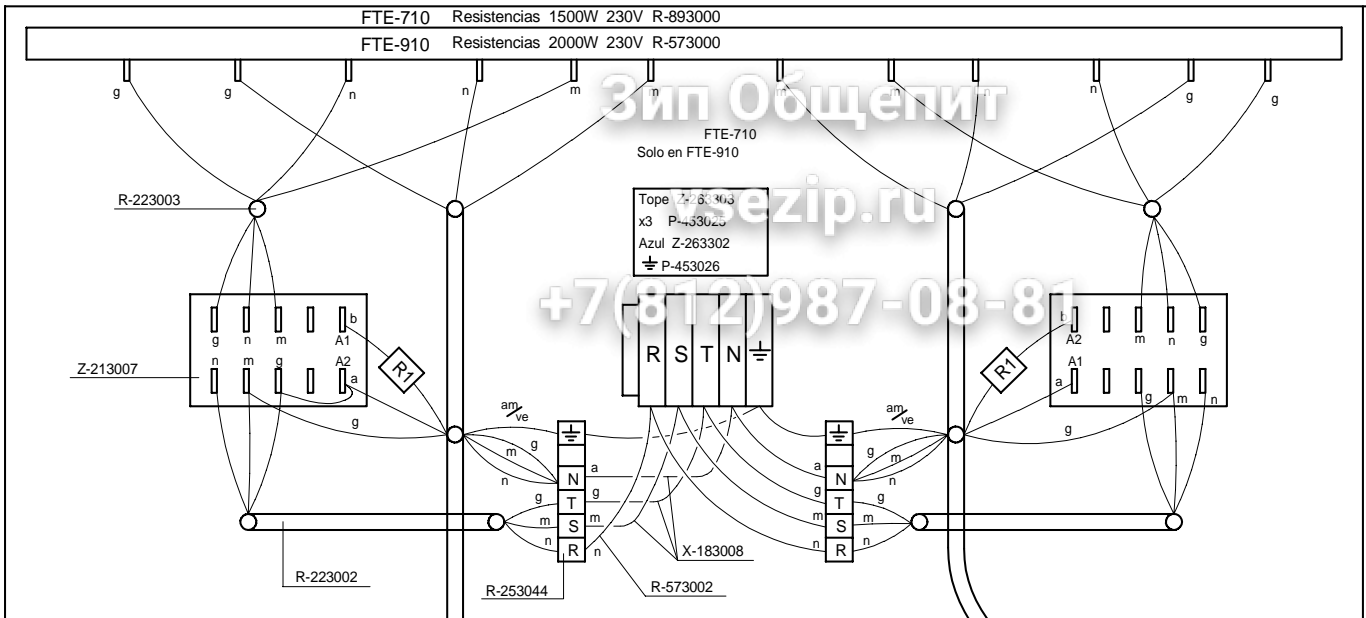

Зип Общепит
 FTE-710
 Solo en FTE-910
 Tope Z-63303
 x3 P-433025
 Azul Z-263302
 P-453026
 +7(812)987-08-81
 sezip.ru

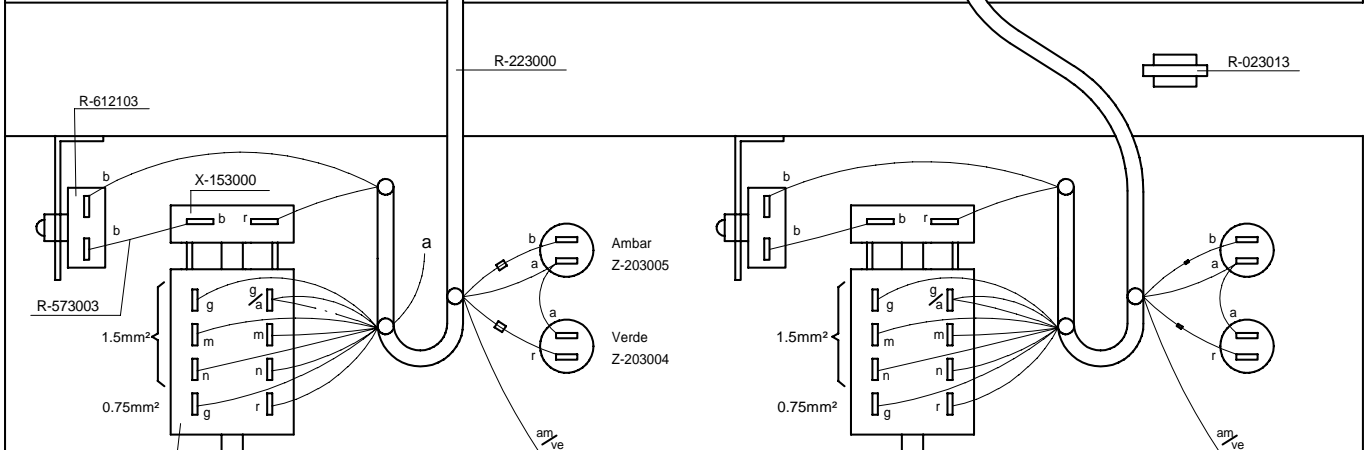

Esquema Adhesivo
 FTE-710 FTE-910 R-573001
 FTE-705 FTE-905 R-563000

VERSION SIN NEUTRO
 -----Conexión
 ■ U-803072 R-150KOhm 1/4W
 □ U-803073 R-8K2Ohm 6W

Esquema de montaje 3N ~ 380V		
Nº	Pieza	
Nº	Modificación	
1	Introducir G-700	
Firma		Fecha
Dibujado JON		95-9-25
Proyectado		
Comprobado		
Escala		
		FRY
Plano hau ez daiteke erabil ez berizta		