

Зип Общепит

DESPIECE TECNICO

vsezip.ru

+7(812)987-08-81

**Cocinas Eléctricas
Fourneaux Electriques
Electric Ranges
Elektro-Herde
Cucine Elettricce**

GAMA 700

Modelos:

CE-720

CE-740

CE-741

Febrero 2003 February



Fagor Industrial

Зип Общепит

vsezip.ru

+7(812)987-08-81

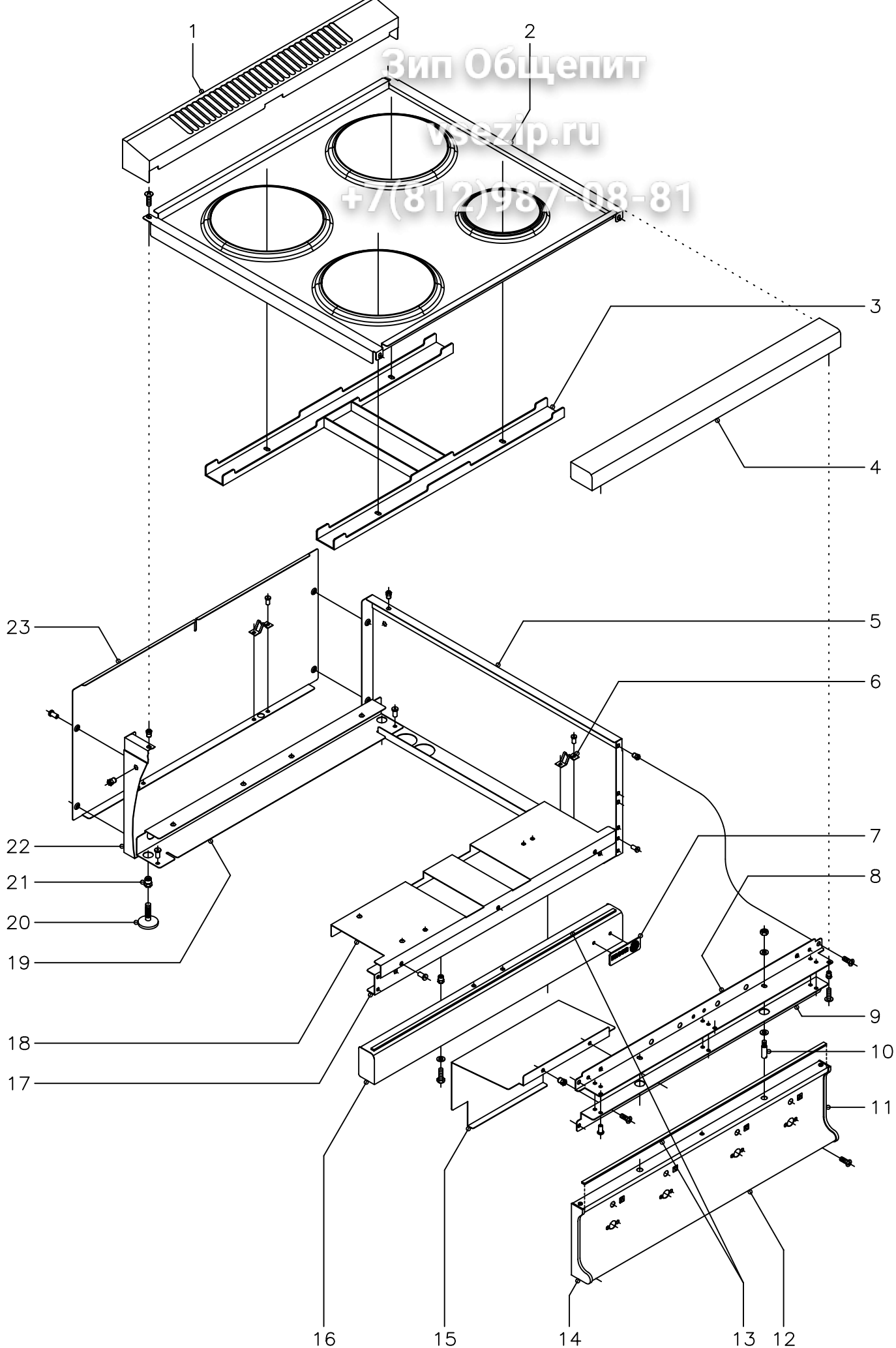

N plano C-1273	Firma 	Fecha 02-2003	Aparato COCINAS CE-720, CE-740	MUEBLE	Lamina 1	Fagor Industrial S.Coop. FAGOR Onate
-------------------	-----------	------------------	-----------------------------------	--------	-------------	--

MOD.	COCINAS ELECTRICAS	ZONA	MUEBLE						
ITEM	CODIGO	DENOMINACION	TEXTO	CE-720	CE-740				
1	X315425	Embellecedor de chimenea 1/2 M.		1	-				
1	U745425	Embellecedor de chimenea 1 M.		-	1				
2	U785400	Mesa 1/2 M.		1	-				
2	U805400	Mesa 1 M.		-	1				
	Q152004	Tornillo aplastado M-5x13		4	4				
	Q221342	Remache exagonal M-5		4	4				
3	U795420	Refuerzo mesa		-	1				
4	X315400	Anterior de mesa 1/2 M.		1	-				
4	U745407	Anterior de mesa 1 M.		-	1				
	Q221342	Remache exagonal M-5		2	3				
	Q152004	Tornillo aplastado M-5x13		2	3				
5	U732802	Panel lateral derecho		1	1				
	Q221343	Remache exagonal M-6		1	1				
6	X010503	Muelle engancho piton		3	4				
	Q419007	Remache tubular Ø3,2x6		6	8				
7	U262806	Escudo FAGOR		1	1				
	Q221023	Clip sujecion escudo		2	2				
8	X312600	Escuadra amarre mesa 1/2 M.		1	-				
8	U742607	Escuadra amarre mesa 1 M.		-	1				
	Q221342	Remache exagonal M-5		2	2				
	Q152004	Tornillo aplastado M-5x13		2	2				
9	X312630	Refuerzo amarre mesa 1/2 M.		1	-				
9	U742620	Refuerzo amarre mesa 1 M.		-	1				
	Q419005	Remache tubular Ø4x8		4	6				
	Q221342	Remache exagonal M-5		2	2				
	Q152004	Tornillo aplastado M-5x13		2	2				
10	Q151336	Tornillo soporte guia		2	2				
	Q302022	Arandela plana Ø16xØ6x1,2		4	4				
	Q162040	Tuerca exagonal M-6		2	2				

Зип Общепит

vsezip.ru

+7(812)987-08-81

MOD.		COCINAS ELECTRICAS	ZONA	MUEBLE				
ITEM	CODIGO	DENOMINACION	TEXTO	CE-720	CE-740			
11	U452804	Cantonera derecha portamandos		1	1			
	Q419005	Remache tubular Ø4x8		2	2			
12	U782800	Panel portamandos 720		1	-			
12	U792800	Panel portamandos 740		-	1			
	Q152004	Tornillo aplastado M-5x13		2	2			
	Q221342	Remache exagonal M-5		2	2			
13	3711100	Perfil esponjoso adhesivo 8x4x350		2	-			
13	3711100	Perfil esponjoso adhesivo 8x4x700		-	2			
14	U452805	Cantonera izquierda portamandos		1	1			
	Q419005	Remache tubular Ø4x8		2	2			
15	U802602	Chapa proteccion conmutadores		1	2			
	Q221342	Remache exagonal M-5		2	4			
	Q152004	Tornillo aplastado M-5x13		2	4			
16	R962800	Zocalo anterior 720		1	-			
16	R972800	Zocalo anterior 740		-	1			
	Q221342	Remache exagonal M-5		2	2			
	Q302022	Arandela plana Ø16xØ6x1,2		2	2			
	Q012031	Tornillo exagonal M-5x10		2	2			
17	U722603	Escuadra anterior base bandejas		1	-			
17	U732601	Escuadra anterior base bandejas		-	1			
	Q419005	Remache tubular Ø4x8		4	4			
18	U782600	Escuadra soporte regleta 720		1	-			
18	U802600	Escuadra soporte regleta 740		-	1			
	Q419005	Remache tubular Ø4x8		2	3			
19	U732600	Escuadra soporte base bandejas		-	1			
	Q419005	Remache tubular Ø4x8		-	2			
20	Z200105	Pata regulable		4	4			
21	Q221345	Remache exagonal M-10		4	4			
22	U732801	Panel lateral izquierdo		1	1			

Зип Общепит

vsezip.ru

+7(812)987-08-81

MOD.	COCINAS ELECTRICAS		ZONA	MUEBLE				
ITEM	CODIGO	DENOMINACION	TEXTO	CE-720	CE-740			
	Q221343	Remache exagonal M-6		1	1			
23	U722803	Panel posterior 1/2 M.		1	-			
23	U732803	Panel posterior 1 M.		-	1			
	Q419005	Remache tubular Ø4x8		4	4			

Зип Общепит
 vsezip.ru
 +7(812)987-08-81

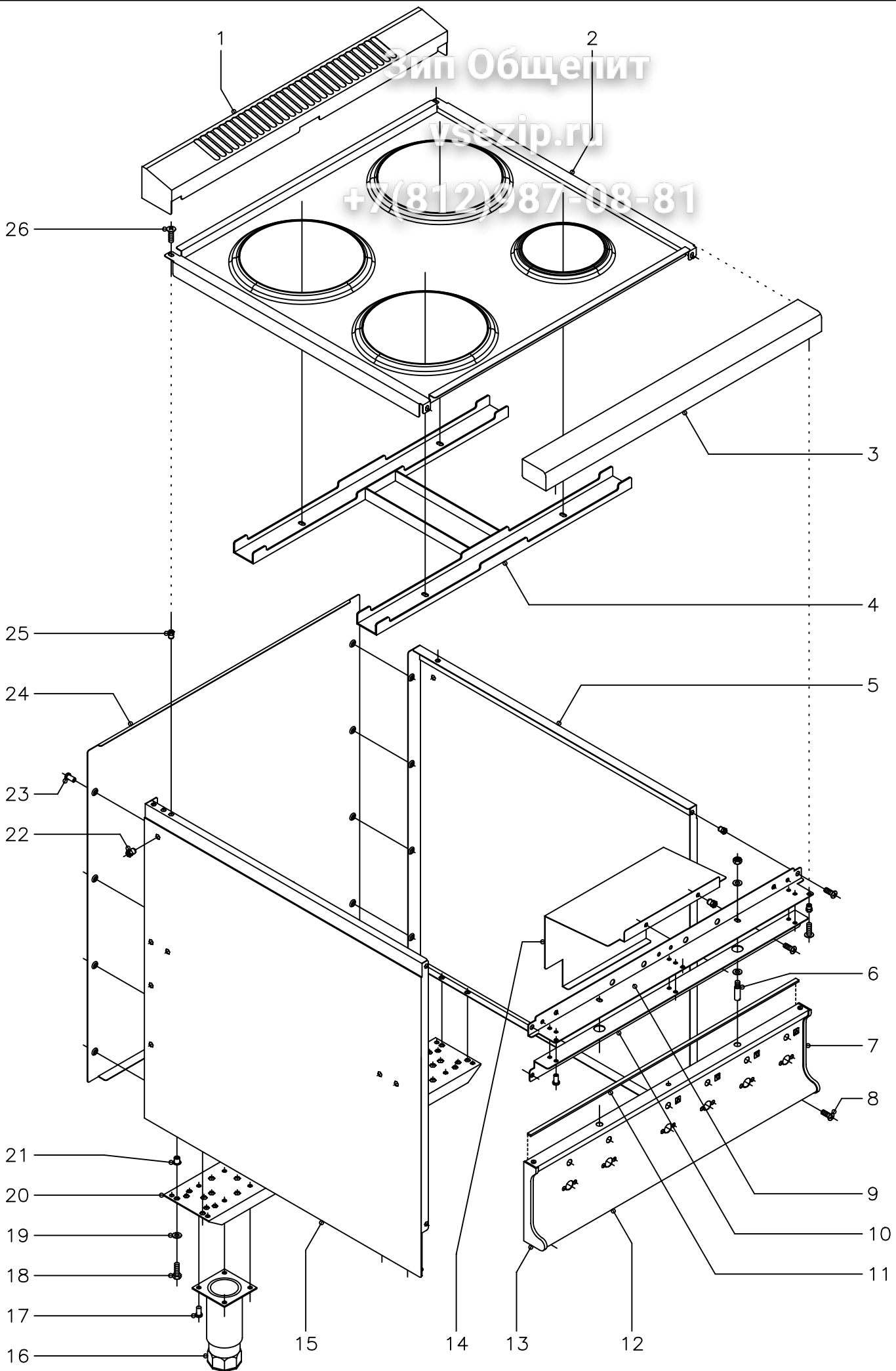

N plano C-1274	Firma <i>Ornava</i>	Fecha 02-2003	Aparato MUEBLE COCINA CE-741	Lamina 2	Fagor Industrial S.Coop. FAGOR Onate
-------------------	------------------------	------------------	------------------------------------	-------------	--

Зип Общепит

vsezip.ru

+7(812)987-08-81

MOD.	COCINAS ELECTRICAS		ZONA	MUEBLE				
ITEM	CODIGO	DENOMINACION	TEXTO	CE-741				
1	U745425	Embellecedor de chimenea 1 M.		1				
2	U805400	Mesa 1 M.		1				
	Q152004	Tornillo aplastado M-5x13		4				
	Q221342	Remache exagonal M-5		4				
3	U745407	Anterior de mesa 1 M.		1				
	Q221342	Remache exagonal M-5		3				
	Q152004	Tornillo aplastado M-5x13		3				
4	U795420	Refuerzo mesa		1				
5	U742811	Panel lateral derecho		1				
	Q221343	Remache exagonal M-6		1				
6	Q151336	Tornillo soporte guia		2				
	Q302022	Arandela plana Ø16xØ6x1,2		4				
	Q162040	Tuerca exagonal M-6		2				
7	U452804	Cantонера derecha portamandos		1				
	Q419005	Remache tubular Ø4x8		2				
8	Q152004	Tornillo aplastado M-5x13		2				
9	U742607	Escuadra amarre mesa 1 M.		1				
	Q221342	Remache exagonal M-5		2				
	Q152004	Tornillo aplastado M-5x13		2				
10	U742620	Refuerzo amarre mesa 1 M.		1				
	Q419005	Remache tubular Ø4x8		6				
	Q221342	Remache exagonal M-5		2				
	Q152004	Tornillo aplastado M-5x13		2				
11	3711100	Perfil esponjoso adhesivo 8x4x700		1				
12	U802800	Panel portamandos 741		1				
	Q152004	Tornillo aplastado M-5x13		2				
	Q221342	Remache exagonal M-5		2				
13	U452805	Cantонера izquierda portamandos		1				
	Q419005	Remache tubular Ø4x8		2				

Зип Общепит



vsezip.ru

+7(812)987-08-81

MOD.	COCINAS ELECTRICAS	ZONA	MUEBLE					
ITEM	CODIGO	DENOMINACION	TEXTO	CE-741				
14	U802602	Chapa proteccion conmutadores		2				
	Q221342	Remache exagonal M-5		4				
	Q152004	Tornillo aplastado M-5x13		4				
15	U742810	Panel lateral izquierdo		1				
16	X260151	Pata regulable		4				
17	Q411304	Remache avibulb Ø4,8		16				
18	Q012043	Tornillo exagonal M-6x20		8				
19	Q302022	Arandela plana Ø16xØ6x1,2		8				
20	U742640	Liston soporte patas 1 M.		2				
21	Q221321	Remache redondo M-6		8				
22	Q221343	Remache exagonal M-6		14				
23	Q419005	Remache tubular Ø4x8		8				
24	U742804	Panel posterior 1 M.		1				
25	Q221342	Remache exagonal M-5		2				
26	Q152004	Tornillo aplastado M-5x13		2				

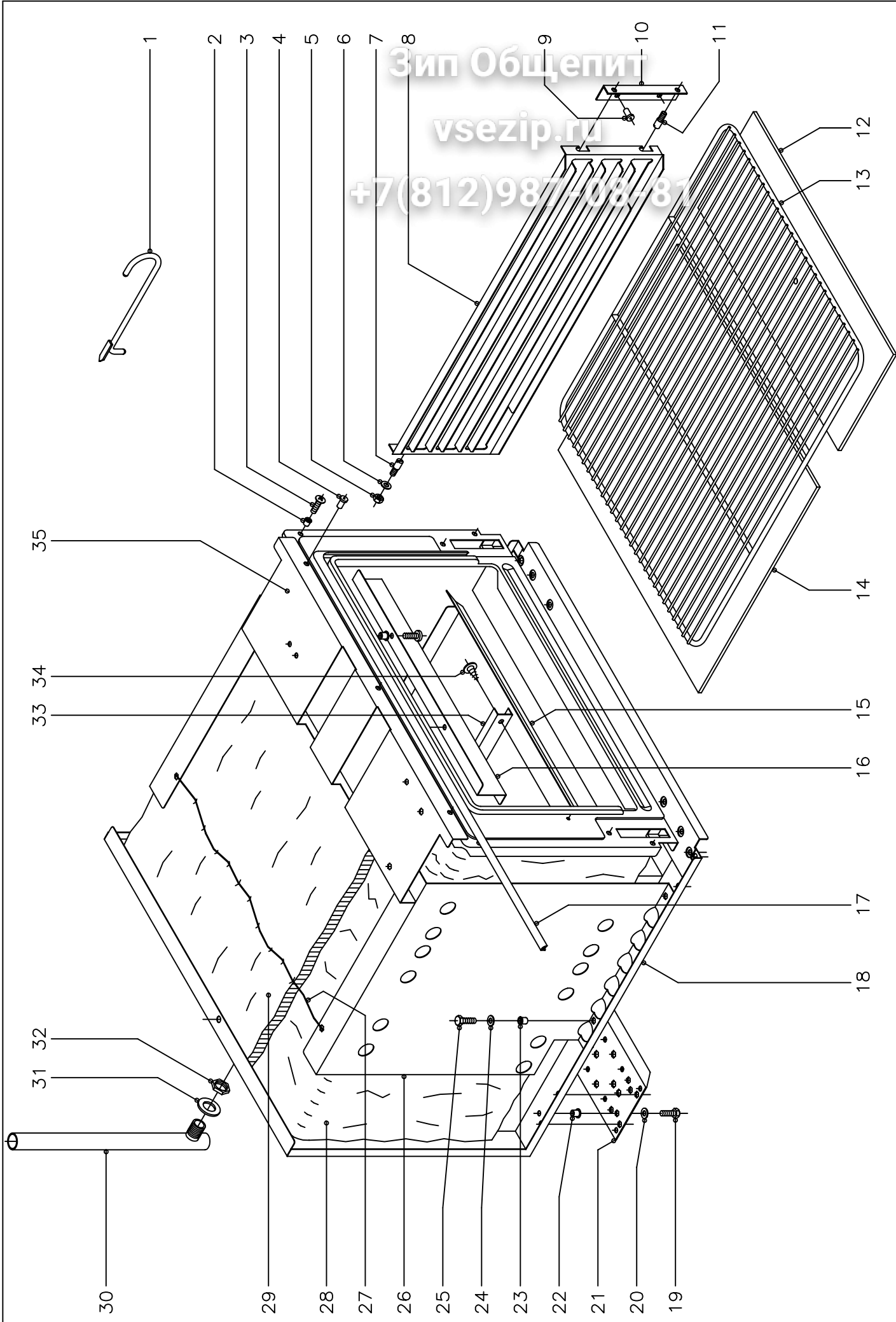
Зип Общепит
 vsezip.ru
 +7(812)987-08-81



N plano C-1275	Firma 	Fecha 02-2003	Aparato HORNO COCINA CE-741	Lamina 3	Fagor Industrial S.Coop. FAGOR  Onate
-------------------	--	------------------	-----------------------------------	-------------	--

Зип Ощепит

vsezip.ru

+7(812)987-08-81

MOD.	COCINAS ELECTRICAS		ZONA	HORNO				
ITEM	CODIGO	DENOMINACION	TEXTO	CE-741				
1	0623600	Palanca levantaplacas		1				
2	Q221304	Remache redondo M-5		4				
3	Q152004	Tornillo aplastado M-5x13		4				
4	Q419005	Remache tubular Ø 4x8		3				
5	Q162040	Tuerca exagonal M-6		4				
6	Q302022	Arandela plana Ø16xØ6x1,2		4				
7	Q151336	Tornillo soporte guias		4				
8	U325608	Guia de bandejas		2				
9	Q419005	Remache tubular Ø 4x8		4				
10	U325611	Escuadra soporte guia bandejas		2				
11	Q151336	Tornillo soporte guias		4				
12	U745630	Cabeza placa de horno		1				
13	U135642	Parrilla de horno		1				
14	U745631	Placa de horno		1				
15	U805606	Base de horno		1				
	Q152004	Tornillo aplastado M-5x13		4				
16	U805609	Amarre soporte superior		1				
	Q221304	Remache redondo M-5		2				
	Q152004	Tornillo aplastado M-5x13		2				
17	U745626	Junta puerta horno		1				
18	U805600	Cuerpo de horno		1				
19	Q012043	Tornillo exagonal M-6x20		4				
20	Q302022	Arandela plana Ø16xØ6x1,2		4				
21	U742640	Liston soporte patas 1 M.		2				
22	Q221321	Remache redondo M-6		4				
23	Q221304	Remache redondo M-5		4				
24	Q302022	Arandela plana Ø16xØ6x1,2		4				
25	Q012031	Tornillo exagonal M-5x10		4				
26	U802601	Sujecion aislante		2				

Зип Общепит

vsezip.ru

+7(812)987-08-81

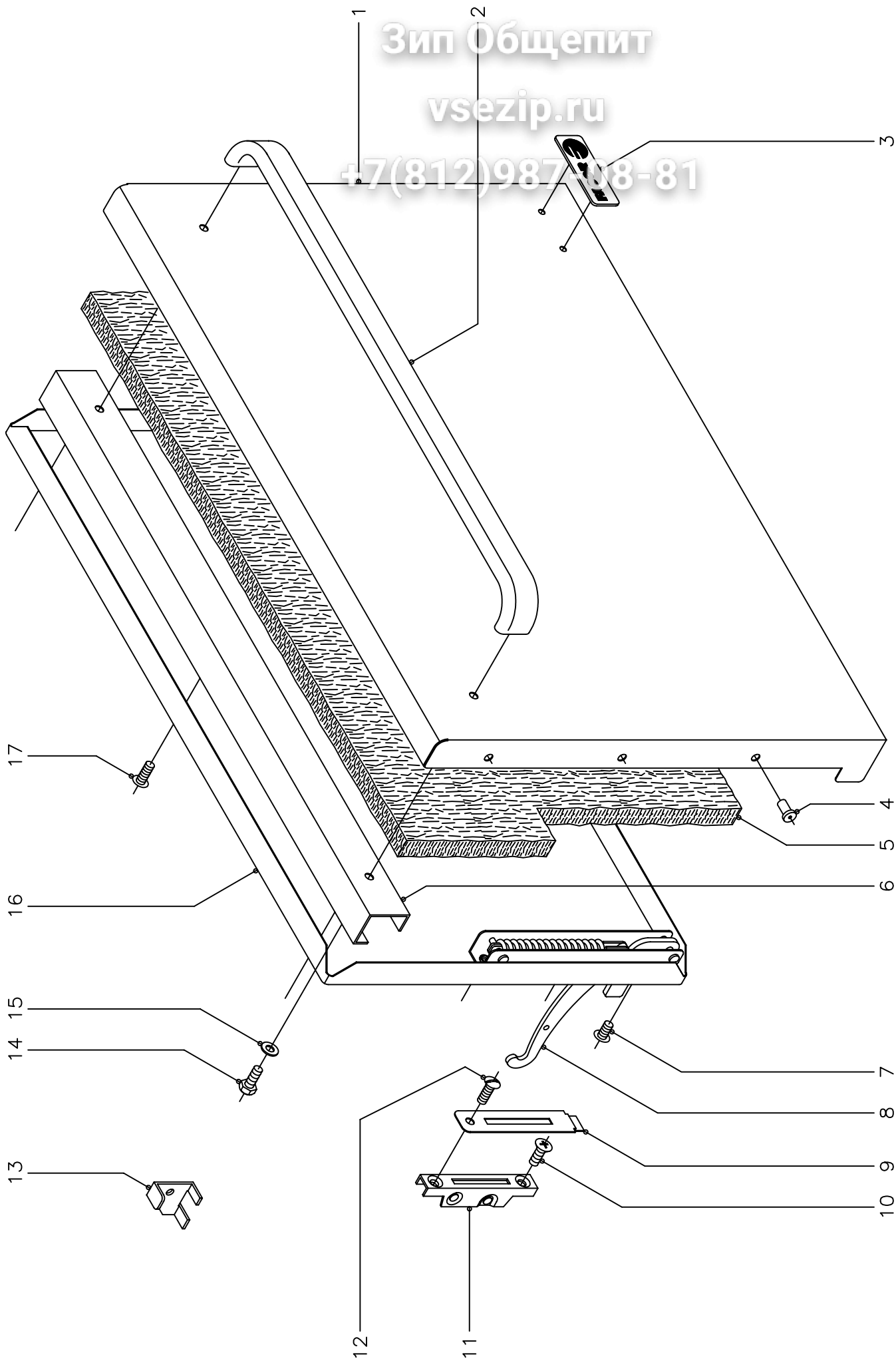

N plano
C-1276

Firma

Fecha
02-2003

Aparato
PUERTA
COCINA CE-741

Lamina
4

Fagor Industrial S.Coop. **FAGOR**
Onate

Зип Общепит

vsezip.ru

+7(812)987-08-81

MOD.		COCINAS ELECTRICAS	ZONA	PUERTA DE HORNO				
ITEM	CODIGO	DENOMINACION	TEXTO	CE-741				
1	U740501	Puerta de horno		1				
2	U580520	Asa de puerta de horno		1				
3	U262806	Escudo FAGOR		1				
	Q221023	Clip sujecion escudo		2				
4	Q419005	Remache tubular Ø4x8		6				
5	U260502	Aislante vitrofib 680x380x20		1				
6	U320507	Refuerzo de puerta		1				
7	Q152022	Tornillo amarre M-6x8		6				
8	U010511	Bisagra izquierda		1				
s/n	U010504	Bisagra derecha		1				
9	U010510	Embellecedor guia bisagra		2				
10	Q042043	Tornillo avellanado M-6x20		2				
11	U010512	Guia de bisagra		2				
12	Q152017	Tornillo amarre M-6x13		2				
13	U746501	Escuadra montaje puerta en horno		2				
14	Q012041	Tornillo exagonal M-6x10		2				
15	Q302022	Arandela plana Ø16xØ6x1,2		2				
16	U260501	Contrapuerta de horno		1				
17	Q152017	Tornillo amarre M-6x13		3				

Зип Общепит

vsezip.ru

+7(812)987-08-81

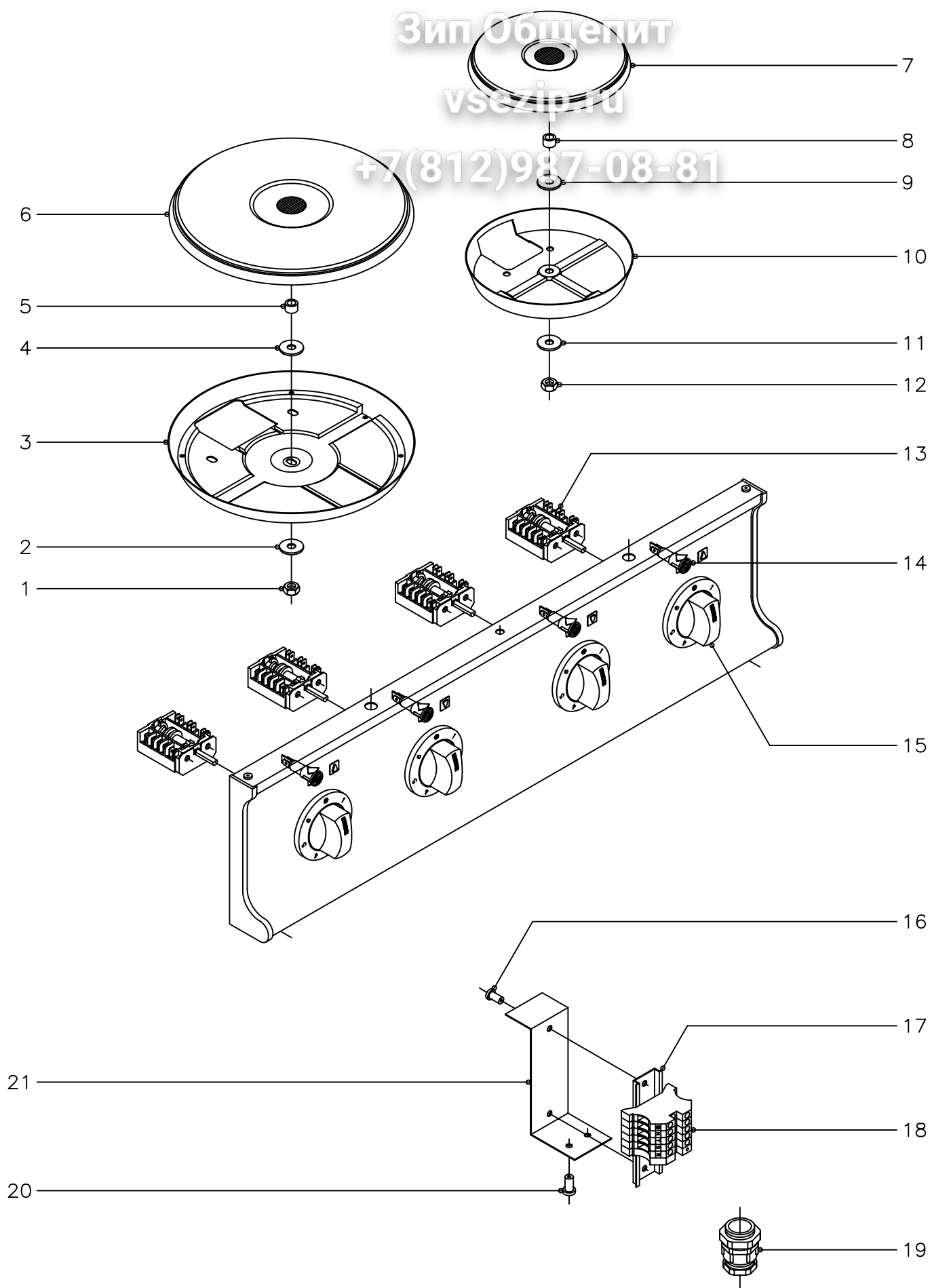

N plano
C-1277

Firma

Fecha
02-2003

Aparato
PARTE FUNCIONAL ELECTRICA
COCINA CE-720, CE-740

Lamina
5

Fagor Industrial S.Coop. **FAGOR**
Onate

Зип Общепит

vsezip.ru

+7(812)987-08-81

MOD.		COCINAS ELECTRICAS	ZONA	PARTE FUNCIONAL ELECTRIC				
ITEM	CODIGO	DENOMINACION	TEXTO	CE-720	CE-740			
1	Q162040	Tuerca exagonal M-6		2	3			
2	Q302022	Arandela plana Ø16xØ6x1,2		2	3			
3	U793030	Cazoleta para 2.600 W.		2	3			
4	Q302022	Arandela plana Ø16xØ6x1,2		2	3			
5	Z608410	Casquillo		2	3			
6	U803000	Placa punto rojo 2.600 W., 230 V.		2	3			
7	U803002	Placa punto rojo 1.500 W., 230 V.		-	1			
8	Z608410	Casquillo		-	1			
9	Q302022	Arandela plana Ø16xØ6x1,2		-	1			
10	U793031	Cazoleta para 1.500 W.		-	1			
11	Q302022	Arandela plana Ø16xØ6x1,2		-	1			
12	Q162040	Tuerca exagonal M-6		-	1			
13	U673007	Conmutador placas		2	4			
14	R693056	Piloto ambar		2	4			
	Q151320	Tornillo alomado M-4x6		4	8			
15	U673015	Boton de mando Ø6		2	4			
	Q281000	Anillo de compresion para mando		2	4			
16	Q419005	Remache tubular Ø4x8		2	2			
17	R663055	Guia contactor L=120		1	1			
18	P453025	Borne fases RST 10 gris		3	3			
	Z263302	Borne neutro N 10 azul		1	1			
	P453026	Borne tierra 10 amarillo-verde		1	1			
	Z263303	Tope final		1	1			
19	R023013	Prensaestopas		1	1			
20	Q419005	Remache tubular Ø4x8		2	2			
21	U792600	Escuadra amarre bornes		1	1			

Zip Общий

vsezip.ru

+7(812)987-08-81

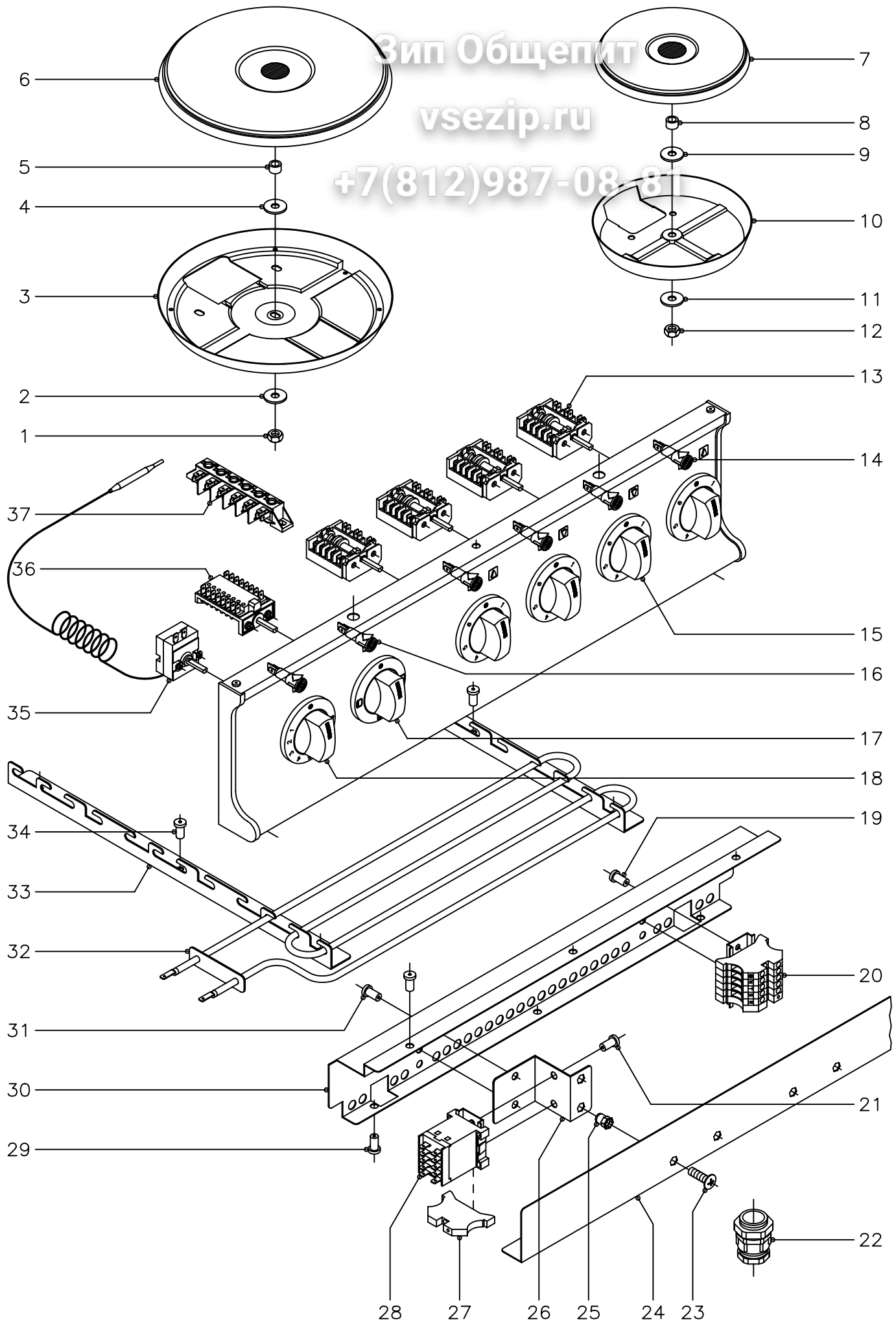

N plano C-1278	Firma 	Fecha 02-2003	Aparato PARTE FUNCIONAL ELECTRICA COCINA CE-741	Lamina 6	Fagor Industrial S.Coop. FAGOR Ofate
-------------------	-----------	------------------	---	-------------	--

Зип Общепит

vsezip.ru

+7(812)987-08-81

MOD.	COCINAS ELECTRICAS		ZONA	PARTE FUNCIONAL ELECTRIC				
ITEM	CODIGO	DENOMINACION	TEXTO	CE-741				
1	Q162040	Tuerca exagonal M-6		3				
2	Q302022	Arandela plana Ø16xØ6x1,2		3				
3	U793030	Cazoleta para 2.600 W.		3				
4	Q302022	Arandela plana Ø16xØ6x1,2		3				
5	Z608410	Casquillo		3				
6	U803000	Placa punto rojo 2.600 W., 230 V.		3				
7	U803002	Placa punto rojo 1.500 W., 230 V.		1				
8	Z608410	Casquillo		1				
9	Q302022	Arandela plana Ø16xØ6x1,2		1				
10	U793031	Cazoleta para 1.500 W.		1				
11	Q302022	Arandela plana Ø16xØ6x1,2		1				
12	Q162040	Tuerca exagonal M-6		1				
13	U673007	Conmutador placas		4				
	Q151320	Tornillo alomado M-4x6		8				
14	R693056	Piloto ambar		5				
15	U673015	Boton de mando Ø6		4				
	Q281000	Anillo de compresion para mando		4				
16	R693055	Piloto verde		1				
17	U673016	Boton de mando Ø6 (Horno)		1				
18	U673017	Boton de mando Ø6 (Termostato)		1				
19	Q419005	Remache tubular Ø4x8		2				
20	Z103083	Guia contactor L=73		1				
	P453025	Borne fases RST 10 gris		3				
	U803009	Borne neutro N 16 azul		1				
	P453026	Borne tierra 10 amarillo-verde		1				
	Z263303	Tope final		1				
21	Q419005	Remache tubular Ø4x8		2				
22	R023013	Prensaestopas		1				
23	Q152004	Tornillo aplastado M-5x13		2				

Зип Общепит

vsezip.ru

+7(812)987-08-81

MOD.		COCINAS ELECTRICAS	ZONA	PARTE FUNCIONAL ELECTRIC				
ITEM	CODIGO	DENOMINACION	TEXTO	CE-741				
24	U805616	Protector regleta y contactor		1				
25	Q221342	Remache exagonal M-5		2				
26	U805615	Soporte contactor		1				
27	Z263303	Tope final		1				
28	Z213007	Contactador 3TF-2010-3AL2		1				
	Z123018	Guia contactor L=55		1				
29	Q419005	Remache tubular Ø4x8		6				
30	U805614	Chapa soporte regleta y contactor		1				
31	Q419005	Remache tubular Ø4x8		2				
32	U803004	Resistencia 1.000 W., 230 V.		6				
33	U805613	Escuadra soporte resistencias		4				
34	Q419005	Remache tubular Ø4x8		12				
35	X153000	Termostato 50 - 310° C.		1				
	Q151320	Tornillo alomado M-4x6		2				
36	U673006	Conmutador horno		1				
	Q151320	Tornillo alomado M-4x6		2				
37	R253044	Regleta auxiliar FV-122		1				
	Q152004	Tornillo aplastado M-5x13		2				

Зип Общепит

vsezip.ru

+7(812)987-08-81

MOD.	COCINAS ELECTRICAS		ZONA	VARIOS				
ITEM	CODIGO	DENOMINACION	TEXTO	CE-720	CE-740	CE-741		
	U806500	Folleto de instrucciones		1	1	1		
	U653003	Cableado bornes a conmutador		1	-	-		
	U673009	Cableado bornes a conmutador		-	1	1		
	U803010	Cableado a placas		2	4	4		
	U803007	Cableado horno contact. a termos.		-	-	1		
	U803008	Cableado horno regleta a conmuta.		-	-	1		
	U803005	Plano de montaje electrico		1	1	1		
	U653001	Esquema electrico adhesivo		1	-	-		
	U663000	Esquema electrico adhesivo		-	1	-		
	U673001	Esquema electrico adhesivo		-	-	1		

MOD.	COCINAS ELECTRICAS		ZONA	VERSION 380 -440 V.,TRIFASICA (SIN I				
ITEM	CODIGO	DENOMINACION	TEXTO	CE-720	CE-740	CE-741		
	U803070	Placa punto rojo 2.600 W. (400 V.)		2	3	3		
	U803071	Placa punto rojo 1.500 W. (400 V.)		-	1	1		
	U803072	Resistencia 150 K., 1/4 W.		2	4	6		
	U803073	Resistencia 8 K 2 , 6 W.		-	-	1		

Зип-Общели
 +7(812)987-08-81

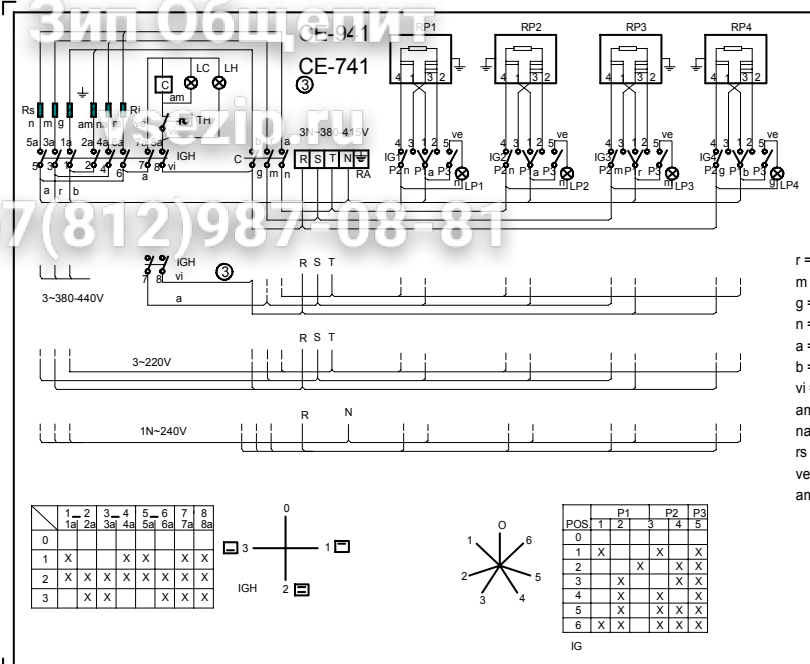

NOTAS

- Fondo: color natural
- Inscripcion letra y recuadro en color negro.
- El sello sera autoadhesivo por la cara posterior y recubierto por un papel protector.
- Las inscripciones resistiran sin modificacion apreciable el frotamiento durante 15 seg. de un algodón impregnado en gasolina.
- Medidas 127x225mm.
- Material: Papel blanco alto brillo

225

RA: Regleta de Alimentacion
 IGH : Conmutador General Horno
 C: Contactor
 LC : Lampara Calentamiento Horno
 LH: Lampara Horno Encendido
 TH : Termostato de Horno
 Rs : Resistencia Horno Superior
 Ri : Resistencia Horno Inferior
 IG,IG2,IG3,IG4 : Conmutadores de placas electricas
 RP1,RP2,RP3,RP4: Placas electricas
 LP1,LP2,LP3,LP4: Lampara Calentamiento de Placas
 TFR: Transformador

Esquema teorico adhesivo		
Nº	Pieza	
Nº	Modificacion	
①	Introducir colores	
②	Modifi. general (pasar a fabri. interior)	
③	Introducir CE-741	
Firma		
Fecha		
Dibujado	JON	95-3-30
Proyectado		
Comprobado	<i>Leto g</i>	
Escala	1/1	
Plano hau ez daiteke erabil ez berizta		

Зип Общепит

vsezip.ru

+7(812)987-08-81

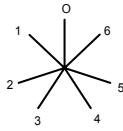

	P1	P2	P3
POS.	1	2	3
0			
1	X		X
2		X	X
3	X		X
4	X	X	X
5	X	X	X
6	X	X	X

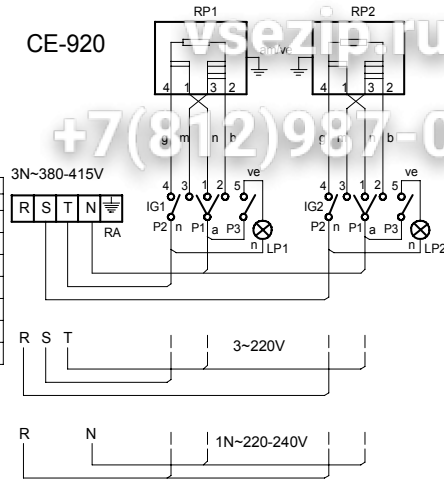

- m = marron-brown-marron
- g = gris-grey-gris
- n = negro-black-noir
- a = azul-blue-bleu
- b = blanco-white-blanc
- ve = verde-green-vert
- am/ve = amarillo/verde-yellow/green-jaune/vert

U-653001

225

NOTA

- Las inscripciones resistirán sin modificación apreciable el frotamiento durante 15 seg. de un algodón impregnado en gasolina.

- RA: Regleta de Alimentación
- IG1, IG2: Conmutadores de placas eléctricas
- RP1, RP2: Placas eléctricas
- LP1, LP2: Lámpara Calentamiento de Placas

Esquema teorico		
Nº	Pieza	
Nº	Modificacion	
Dibujado	Firma	Fecha
Proyectado	Plazaola	21-4-97
Comprobado		
Escala		
1/1		C
Plano hau ez daiteke erabil ez berritza		

CE-940

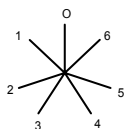

POS.	P1		P2		P3	
	1	2	3	4	5	6
0						
1	X		X		X	
2			X		X	X
3	X				X	X
4		X		X		X
5	X	X	X	X	X	X
6	X	X	X	X	X	X

r = rojo-red-rouge
 m = marron-brown-marron
 g = gris-grey-gris
 n = negro-black-noir
 a = azul-blue-bleu
 b = blanco-white-blanc
 ve = verde-green-vert
 am/ve = amarillo/verde-yellow/green-jaune/vert

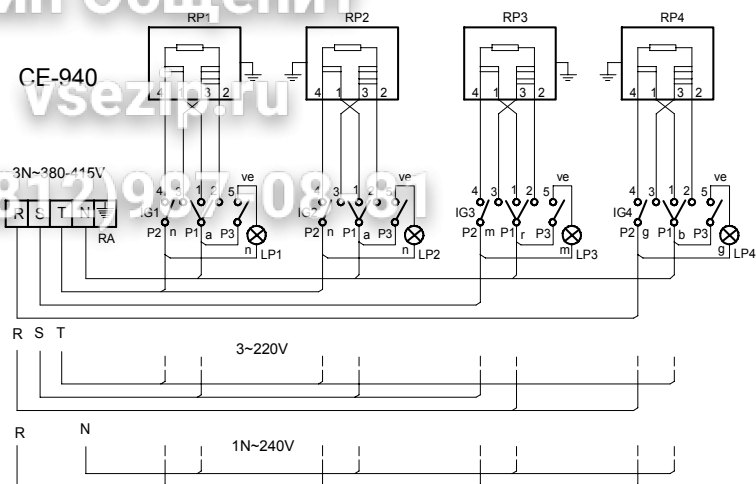

U-663000

225

NOTA

- Las inscripciones resistirán sin modificación apreciable el frotamiento durante 15 seg. de un algodón impregnado en gasolina.

RA: Regleta de Alimentación
 IG1, IG2, IG3, IG4: Conmutadores de placas eléctricas
 RP1, RP2, RP3, RP4: Placas eléctricas
 LP1, LP2, LP3, LP4: Lámpara Calentamiento de Placas

Esquema teorico		
Nº	Pieza	
Nº	Modificación	
Firma		Fecha
Dibujado	Plazaola	22-4-97
Proyectado		
Comprobado		
Escala		
1/1		C
Plano hau ez daiteke erabil ez berri...		

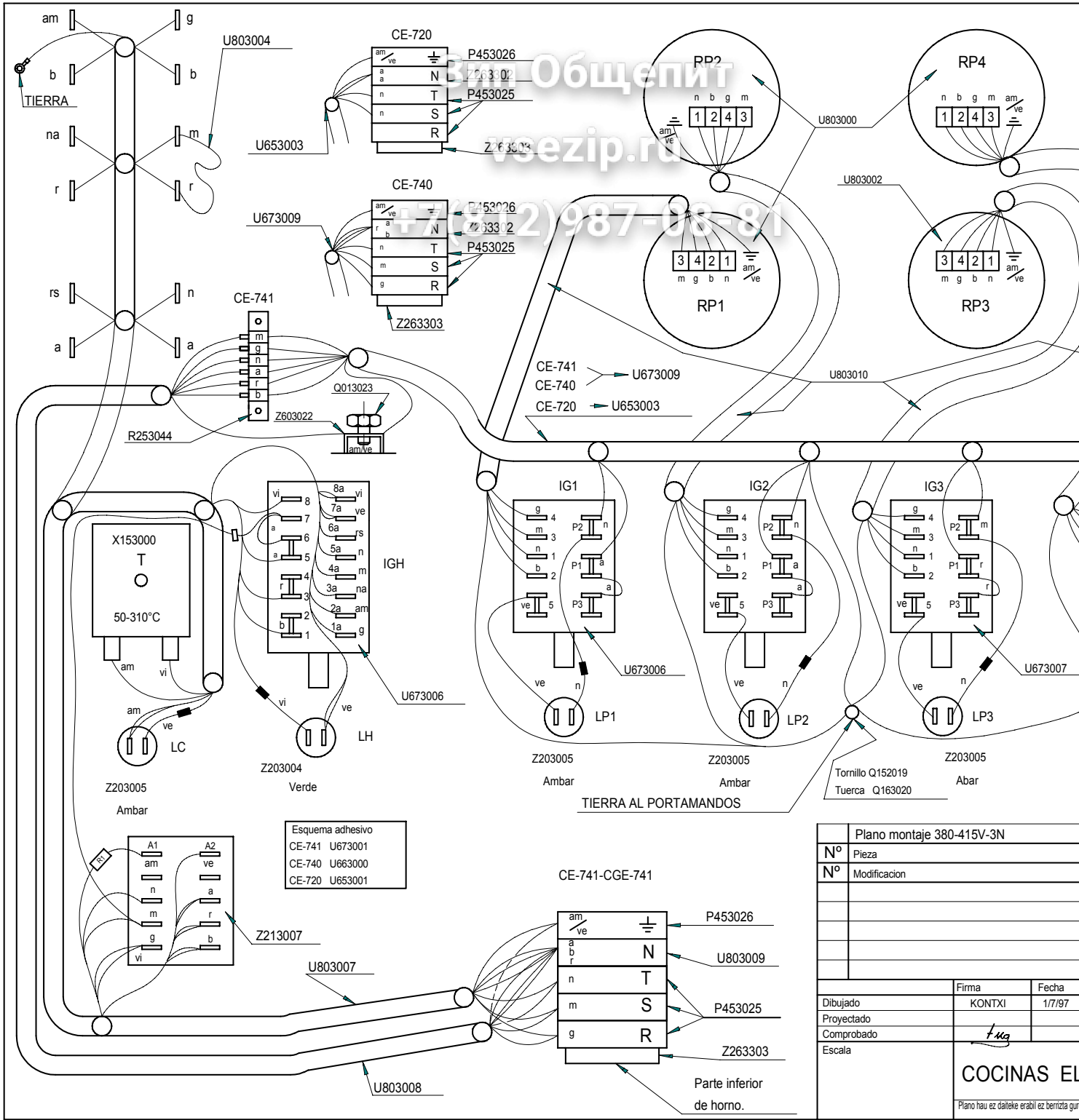

Plano montaje 380-415V-3N		
Nº	Pieza	
Nº	Modificacion	
Dibujado		Firma
Proyectado		KONTXI
Comprobado		17/197
Escala		<i>[Signature]</i>
COCINAS EL		
Plano hau ez datatze erabil ez berritza gura		