

Зип Общепит

vsezip.ru

+7(812)927-08-81

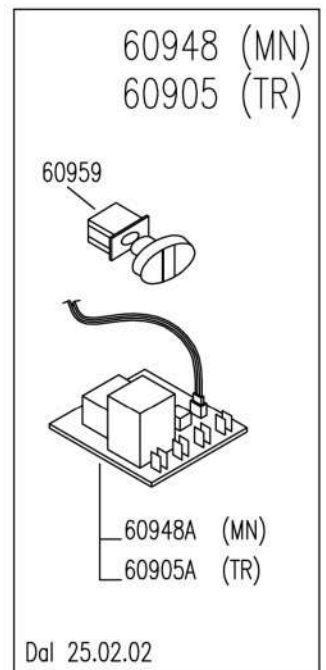
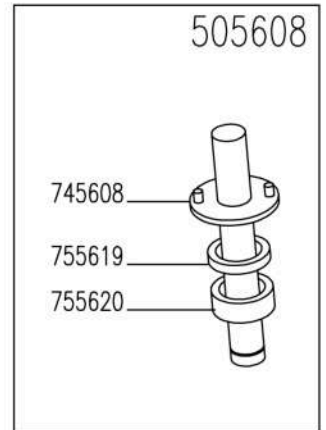
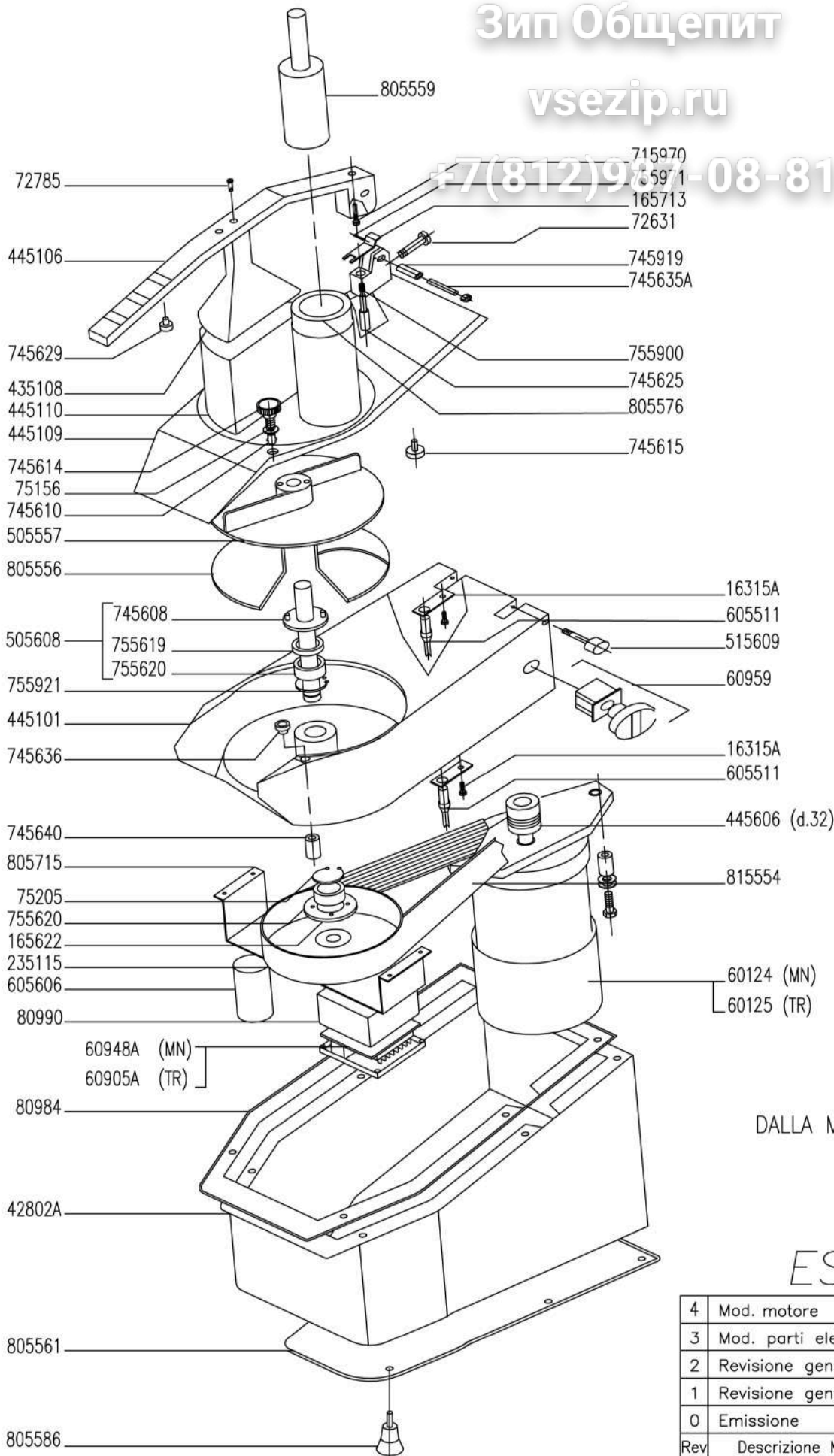

DALLA MATRICOLA: 11020001

ESPLOSO

4	Mod. motore	25.02.11	PF	BP
3	Mod. parti elettriche	25.02.02	PF	BP
2	Revisione generale	01.06.99	BP	TA
1	Revisione generale	10.01.99	BP	TA
0	Emissione	01.01.95	BP	TA
Rev	Descrizione Modifica	Data	Firma	Approv.



LA DITTA CELME SI RISERVA
TUTTI I DIRITTI A TERMINE
DI LEGGE.

Mod. CHEF 400

Cod. 913001-05