

Зип Общепит W
Wexiödisk
vsezip.ru

+7(812)987-08-81
**HOOD TYPE DISHWASHER
WD-6**

(translation of the original documentation)



Read the manual before use!

Spare parts manual



WD67r1

1. Spare parts	1
1.1 External details	2
1.2 Hood lift	4
1.3 Tank details	6
1.4 Wash and rinse system	8
1.5 Water connections booster heater	10
1.6 Booster heater 400V 9kW	12
1.7 Booster heater (Option)	14
1.8 Booster heater (Option)	16
1.9 Booster heater (Option)	18
1.10 Electric cubicle	20
1.11 Coupling incoming water (WD6 & WD7 with break tank)	22
1.12 Valve package (WD-6C & WD6 & WD7 without hood lift)	24
1.13 Valve package (WD-6 & WD-7 with hoodlift & with breaktank)	26
1.14 Valve package (WD-6 & WD-7 with hoodlift)	28
1.15 Booster pump with breaktank (option)	30
1.16 Breaktank (option)	32
1.17 Booster pump without breaktank (option)	34
1.18 Emptying pump (option)	36
1.19 Backflow prevention device (option)	38
1.20 Rebuilding kit 460 basket (option)	40
1.21 Heat recovery by the exhausted steam (option)	42
1.22 Heat recovery by the drain water (option)	44
1.23 Pump 1295	46

vsezip.ru

+7(812)987-08-81

1. Spare parts



Switch off the dishwasher immediately and make sure it is non-live in the event of a fault or malfunction. The machine must only be serviced by trained personnel. Use original spare parts. Warranty repairs must be performed by an authorised company. For authorised service companies, please see www.wexiodisk.com or contact Wexiödisk AB.

If an item does not have a part number, it has a dedicated section in the spare parts manual or it is an electrical component. Electrical components must always be checked against the machine's wiring diagram.

Positions that have a * in front of the name is included in a complete article but can also be purchased separately.

1.1 External details

vsezip.ru

+7(812)987-08-81

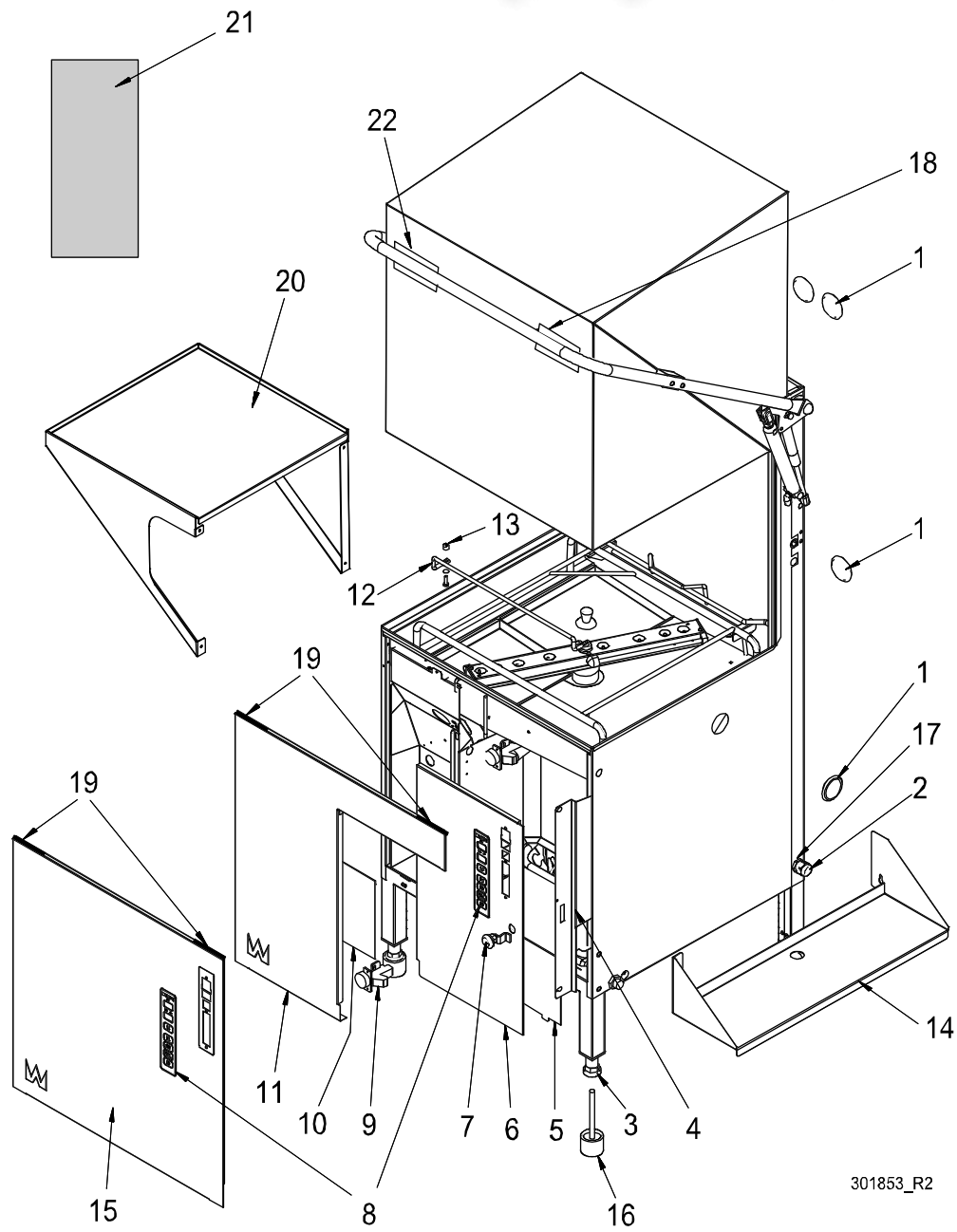

301853_R2

External details			
Pos	WD no.	Description	Comment
1	WD718.1070	Plug	
2	WD51476114	Cable screw cap polyamid	
3	WD718.0305	Foot grey adjustable	
3	WD42820.31	Foot plate (Option)	
4	WD300684.31	Cabinet (Option)	
5	WD300958.31	Base-cabinet (Option)	
6	WD26923.31	Panel plate (Option)	
7	WD792.0220	Cylinder lock (Option)	
8	WD301060.01	Panel sign WD6	
8	WD301736.01	Panel sign WD-6 Metos	
8	WD301060.02	Panel sign WD-6 automatic hood (Option)	
8	WD301736.02	Panel sign WD-6 Metos Rhima automatic hood (Option)	
8	WD696.0404	Panel sign WD-6 Comenda automatic hood (Option)	
9	WD790.0301	Hinge door (Option)	
10	WD724.0502	Plastic case A4	
11	WD27366.31	Front plate (Option)	
12	WD44880.31	Side support	
13	WD44930.31	Distance basket frame rail	
14	WD27316.31	Shelf (Option)	
15	WD27367.01	Front plate right with bumping	
15	WD27367.02	Front plate left without bumping (Option)	
15	WD27367.03	Front plate right without bumping	
16	WD46202.01	Extension leg (Option)	
17	WD51476534	Locking nut polyamid	
18	WD45941.31	Model sign WD	
18	WD42752.31	Model sign Metos	
18	WD42909.31	Model sign Rhima	
18	WD46094.31	Model sign Ravimo / Shark	
18	WD203.0611CO	Model sign Comenda	
19	WD719.0512	Sealing strip	
20	WD27362.31	Sideboard	
21	WD724.6006	Quick reference WD-6/WD-7 without hood lift	
21	WD724.6024	Quick guide to WD-6/WD-7 without hood lift and with drain pump (optional)	
21	WD724.6005	Quick reference WD-6/WD-7 with hood lift (Option)	
21	WD724.6025	Quick guide to WD-6/WD-7 with hood lift and with drain pump (optional)	
22	WD400127.31	Model sign Proofline Brønnum	

1.2 Hood lift

vsezip.ru

+7(812)987-08-81

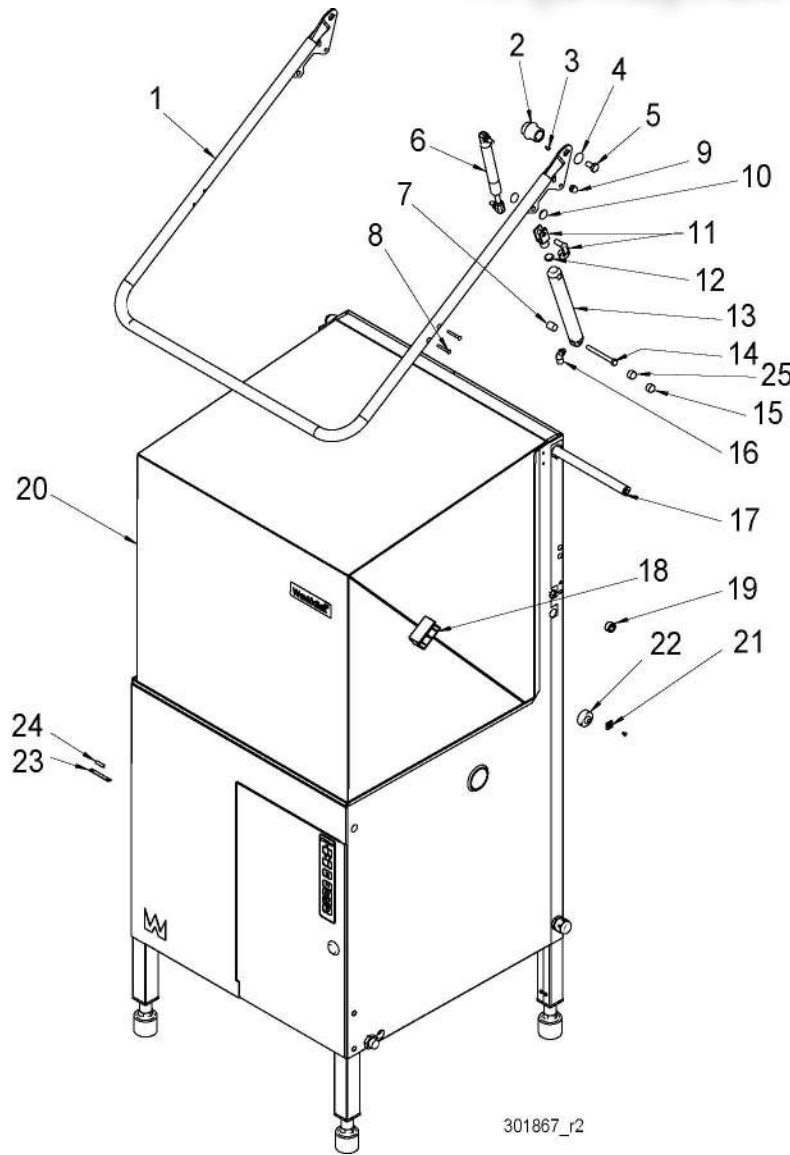

Hood lift			
Pos	WD no.	Description	Comment
1	WD301419.01	Lifting handle cp.	
2	WD45256.31	Bearing liftclamp	
3	WD700.0207	Screw	
4	WD45310.31	Washer	
5	WD700.0148	Screw	
6	WD713.1506	Gas spring 500N	
7	WD701.0110	Distance cylinder hold (Option)	
8	WD700.0824	Screw	
9	WD700.1110	Nut	
10	WD701.0115	Plastic washer (Option)	
11	WD737.0150	Fork link (Option)	
12	WD737.0153	Nut (Option)	
13	WD737.3000	Cylinder (Option)	
14	WD46217.31	Pin bolt for hood lift (Option)	
15	WD718.1108	Nut cover (Option)	
16	WD706.0915	L-coupling (Option)	
17	WD301420.31	Axle hood lift	
18	WD41223.31	Hood bearing WD6/7	
19	WD61701519	Conduit entry	
20	WD11037.01	Hood	
21	WD40016.31	* Sliding block	
22	WD41224.31	* Sliding roller	
23	WD46521.31	* Magnet holder	
24	WD602.0551	* Magnet	
25	WD700.0920	Nut	

1.3 Tank details

vsezip.ru

+7(812)987-08-81

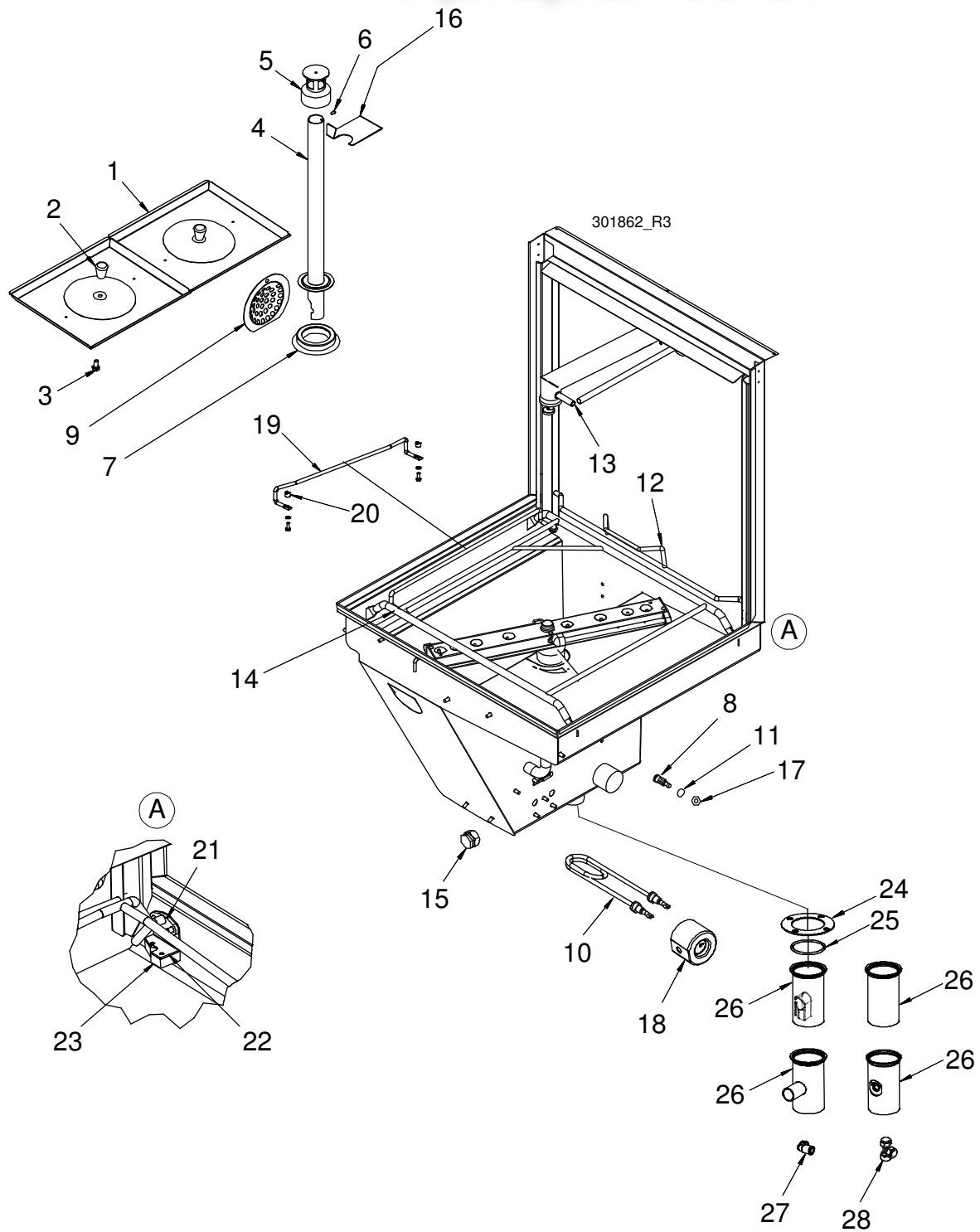

Tank details			
Pos	WD no.	Description	Comment
1	WD301689.01	Chem strainer	
2	WD718.0826	* Nob	
3	WD700.2864	* Screw	
4	WD38210.01	Level pipe	
5	WD41225.31	* Foam remover	
6	WD700.0607	* Screw	
7	WD719.4036	Level pipe sealing	
8	WD48127.31	Detergent connection	
9	WD32422.31	Pumpstrainer chemical	
10		Element	See the machine's wiring diagram
11	WD400153.31	Gasket	
12	WD741.7010	Autostart spare parts kit (Option)	
	WD304150.75	* Breaker with axle	
	WD602.0551	** Magnet round	
	WD701.2010	* Stop collar	
		* Fieldbreaker switch	See the machine's wiring diagram
13	WD705.1212	Coupling angled	
14	WD304710.01	Folding basket conveyor	
15	WD705.1022	Coupling test pressure	
	WD705.0323	* Clamping sleeve	
	WD705.0207	* Nut	
16	WD46198.31	Level pipe support (Option)	
17	WD51476533	Lock nut	
18	WD46165.31	Protective cover element	
19	WD44880.31	Side support basket conveyor	
20	WD44930.31	Distance basket conveyor	
21	WD47372.31	Attachment basket conveyor	
22	WD47391.31	Attachment basket conveyor	
23	WD47393.31	Sliding wedge basket conveyor	
24	WD46676.31	Washer threaded nipple	
25	WD719.1092	O-ring	
26	WD302871.01	Threaded nipple	
26	WD302873.01	Threaded nipple, (Option)	Autohood. Drain pump & autohood
26	WD46680.31	Threaded nipple, (Option)	Drain pump
26	WD302870.02	Threaded nipple, (Option)	Condensing unit. Condensing unit & autohood. Condensing unit & drain pump. Condensing unit & drain pump & autohood
27	WD706.0915	L-coupling (Option)	Autohood. Drain pump & autohood
28	WD705.2205	T-coupling (Option)	Condensing unit & autohood. Drain pump & condensing unit & autohood
	WD705.0420	* Clamping sleeve	
	WD705.0315	* Nut	

Wash and rinse system			
Pos	WD no.	Description	Comment
1	WD44625.31	Sealing upper rinse pipe	
2	WD304250.02	Main pipe	
3	WD44626.31	Rubber stopping lower rinse pipe	
4	WD705.2706	T-Coupling	
5		Pump with attachment, cpl	See the machine's wiring diagram
6	WD714.0112	Hose clamp	
7	WD36364.31	Pump connection inlet	
8	WD714.0111	Hose clamp	
9	WD38232.31	Pump connection	
10	WD700.0132	Screw	
11	WD44600.31	Neck	
12	WD719.0111	V-ring	
13	WD46086.01	Lower sleeve coupling	
14	WD27252.01	Rinse arm, cpl	
15	WD46852.01	* Rinse arm bearing, cpl	
16	WD38719.31	* End cover	
17	WD45136.01	* Rinse pipe	
18	WD44969.31	* Rinse pipe attachment	
19	WD45136.02	* Rinse pipe	
20	WD700.2001	* Screw	
21	WD46335.31	Adjusting washer	

1.5 Water connections booster heater

+7(812)987-08-81

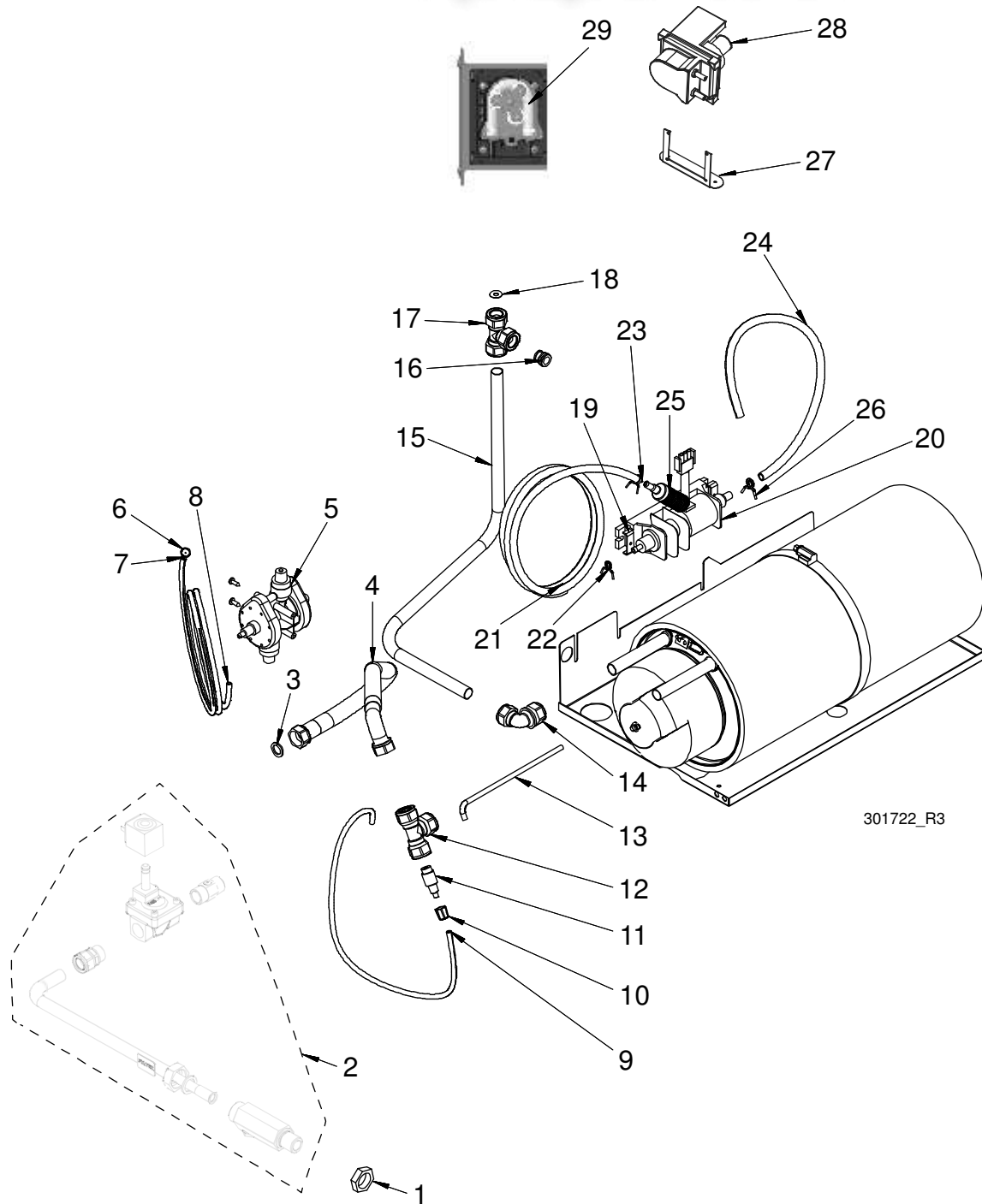

301722_R3

Water connections booster heater vsezip.ru			
Pos	WD no.	Description	Comment
1	WD706.0203	Nut	
2		Incoming water valve & Packages	Depending on what the machine is equipped with. See separate section.
3	WD701.0122	Gasket	
4	WD400199.01	Hose	L=510mm
5	WD716.0401	Drying agent pump N6	
	WD741.7042	Maintenance kit drying kit agent	
6	WD716.0404	* Strainer	
7	WD42946.31	* Reinforcement pin	
8	WD716.0402	* Hose	L=2m
9	WD716.0405	* Pressure hose	L=0,6m
10	WD716.0403	Attachment nut N6	
11	WD45985.31	Connection nipple	
12	WD705.2601	Coupling	
	WD705.0405	* Clamping sleeve	
	WD705.0205	* Nut	
13	WD45994.31	Tube drying agent connection	
14	WD705.1617	Coupling angle	
	WD705.0420	* Clamping sleeve	
	WD705.0316	* Nut	
15	WD301069.31	Tube booster heater final rinse	
16	WD705.0421	Clamping sleeve	
17	WD705.2215	T-Coupling	
	WD705.0420	* Clamping sleeve	
	WD705.0316	* Nut	
18	WD46188.31	Adjusting plate	
19	WD48101.31	Clamp detergent pump (Option)	
20		Detergent pump GRI (Option)	See the machine's wiring diagram
	WD741.7041	Maintenance kit detergent, GRI (Option)	
21	WD719.0305	* Hose	L=2,3m
22	WD714.0408	* Clamping sleeve	
23	WD42887.31	* Reinforcement pin	
24	WD719.0307	* Hose	L=0,5m
25	WD716.0504	* Detergent pump strainer	
26	WD714.0411	* Hose	
27	WD400111.31	Clamp detergent pump SEKO (Option)	
28		Detergent pump SEKO (Option)	See the machine's wiring diagram
	WD741.7046	Maintenance kit detergent, SEKO (Option)	
29	WD716.0442	* Pumphouse	
	WD716.0441	* Front cover pump	

1.6 Booster heater 400V 9kW vsezip.ru

+7(812)987-08-81

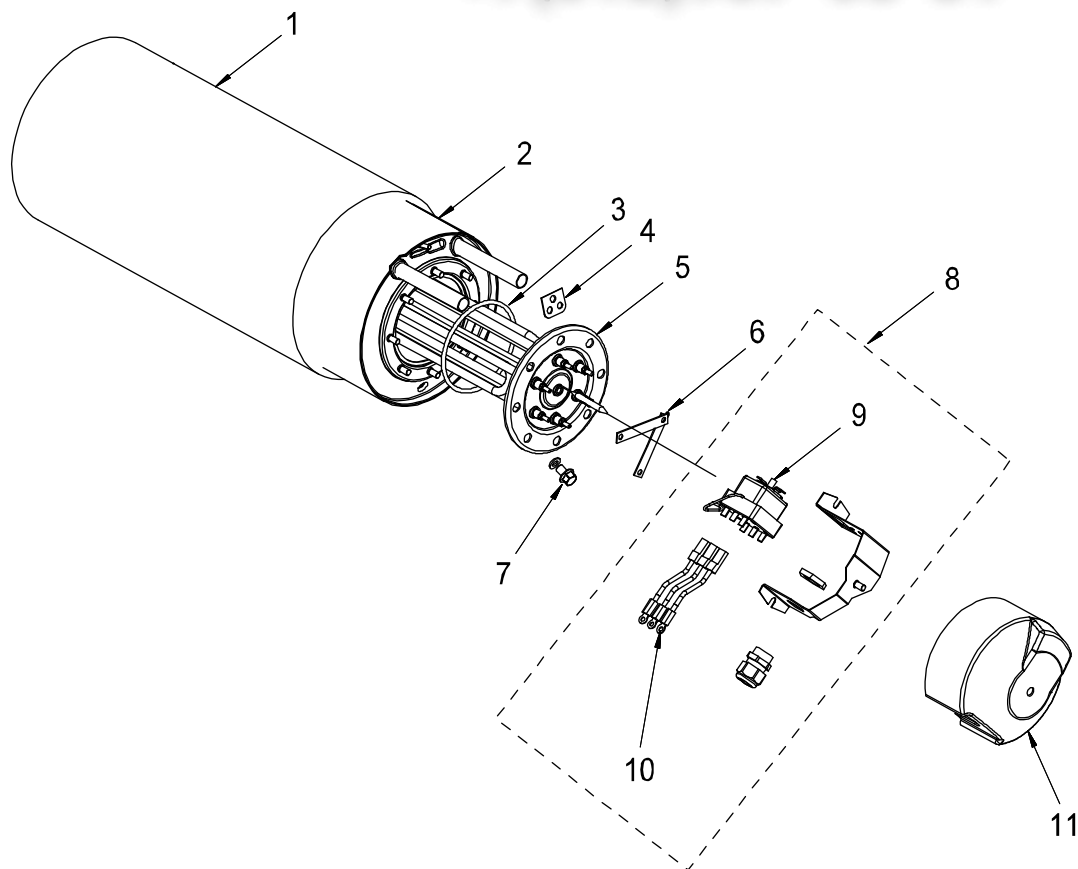

Gstr_4_1

Booster heater 400V 9kW			
Pos	WD no.	Description	Comment
	WD01163.36	Booster heater 400V 9kW	
1	WD809.0903	* Heat insulation booster heater	
2	WD01162.04	* Container booster heater (E)	
3	WD719.1090	* O-ring	
4	WD44203.31	* Attachment temp.sensor	
5		* Element	See the machine's wiring diagram
6	WD04920.31	* Copper clamp	
7	WD700.2501	* Collar screw + Gasket	
8	WD302113.01	* Overheating protection tank element (400-415V), cpl	
9		** Overheating protection	See the machine's wiring diagram
10	WD670.8244	** Coupling conductor	
11	WD301321.31	Protection cover	

1.7 Booster heater (Option)

vsezip.ru

+7(812)987-08-81

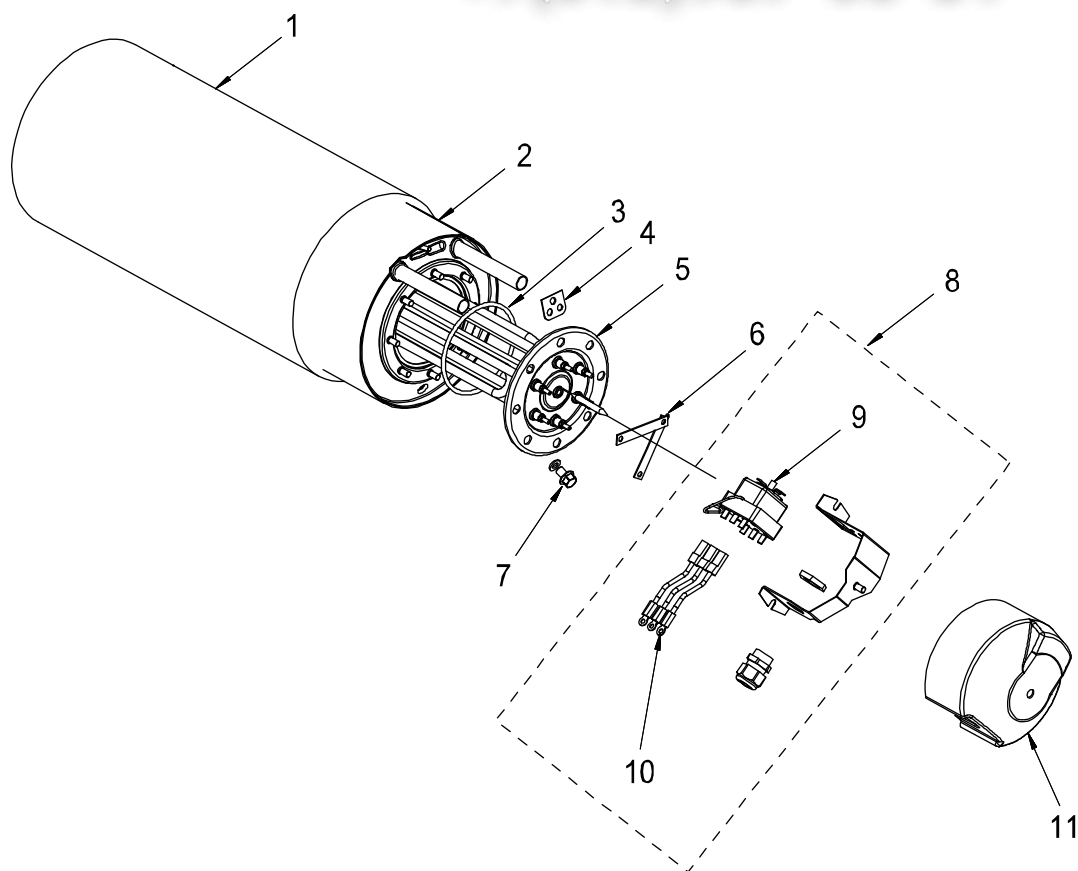

Gstr_4_1

Booster heater (Option)			
Pos	WD no.	Description	Comment
	WD01163.39	Booster heater 440V 9kW	
	WD01163.40	Booster heater 400V 12kW	
	WD01163.42	Booster heater 440V 12kW	
	WD01163.48	Booster heater 400V 15kW	
1	WD809.0903	* Heat insulation booster heater	
2	WD01162.04	* Container booster heater (E)	
3	WD719.1090	* O-ring	
4	WD44203.31	* Attachment temp.sensor	
5		* Element	See the machine's wiring diagram
6	WD04920.31	* Copper clamp	
7	WD700.2501	* Collar screw + Gasket	
8	WD302113.01	* Overheating protection tank element (400-415V), cpl	
9		** Overheating protection	See the machine's wiring diagram
10	WD670.8244	** Coupling conductor	
11	WD301321.31	Protection cover	

1.8 Booster heater (Option)

vsezip.ru

+7(812)987-08-81

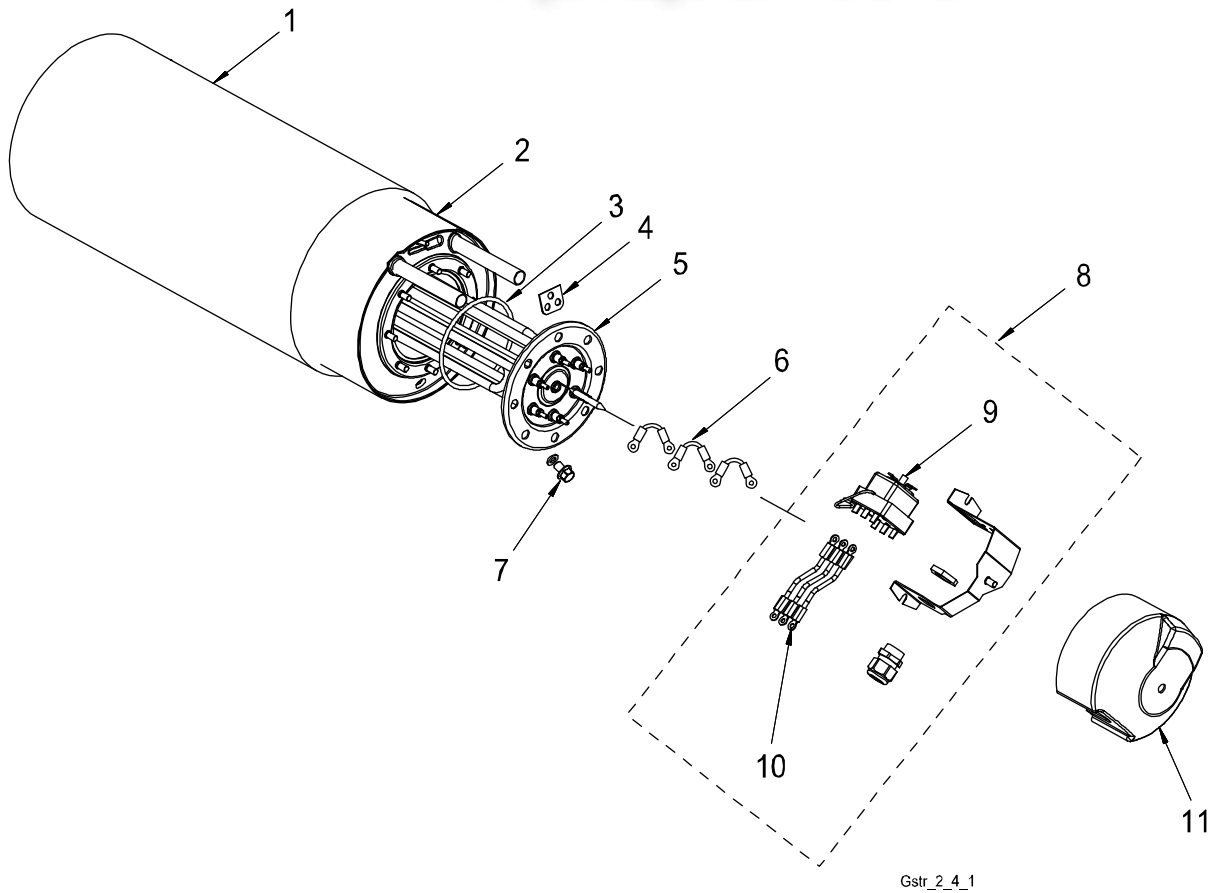

Gstr_2_4_1

Booster heater (Option)			
Pos	WD no.	Description	Comment
	WD01163.35	Booster heater 230V 9kW	
	WD01163.37	Booster heater 200V 9kW	
	WD01163.46	Booster heater 230V 1N 50Hz 6kW	
	WD01163.47	Booster heater 230V 12kW	
1	WD809.0903	* Heat insulation booster heater	
2	WD01162.04	* Container booster heater (E)	
3	WD719.1090	* O-ring	
4	WD44203.31	* Attachment temp.sensor	
5		* Element	See the machine's wiring diagram
6	WD67182105	* Cable bridge	
7	WD700.2501	* Collar screw + Gasket	
8	WD302113.02	* Overheating protection tank element (200-230V & 400-415V), cpl	
9		** Overheating protection	See the machine's wiring diagram
10	WD670.8245	** Coupling conductor	
11	WD301321.31	Protection cover	

1.9 Booster heater (Option)

vsezip.ru

+7(812)987-08-81

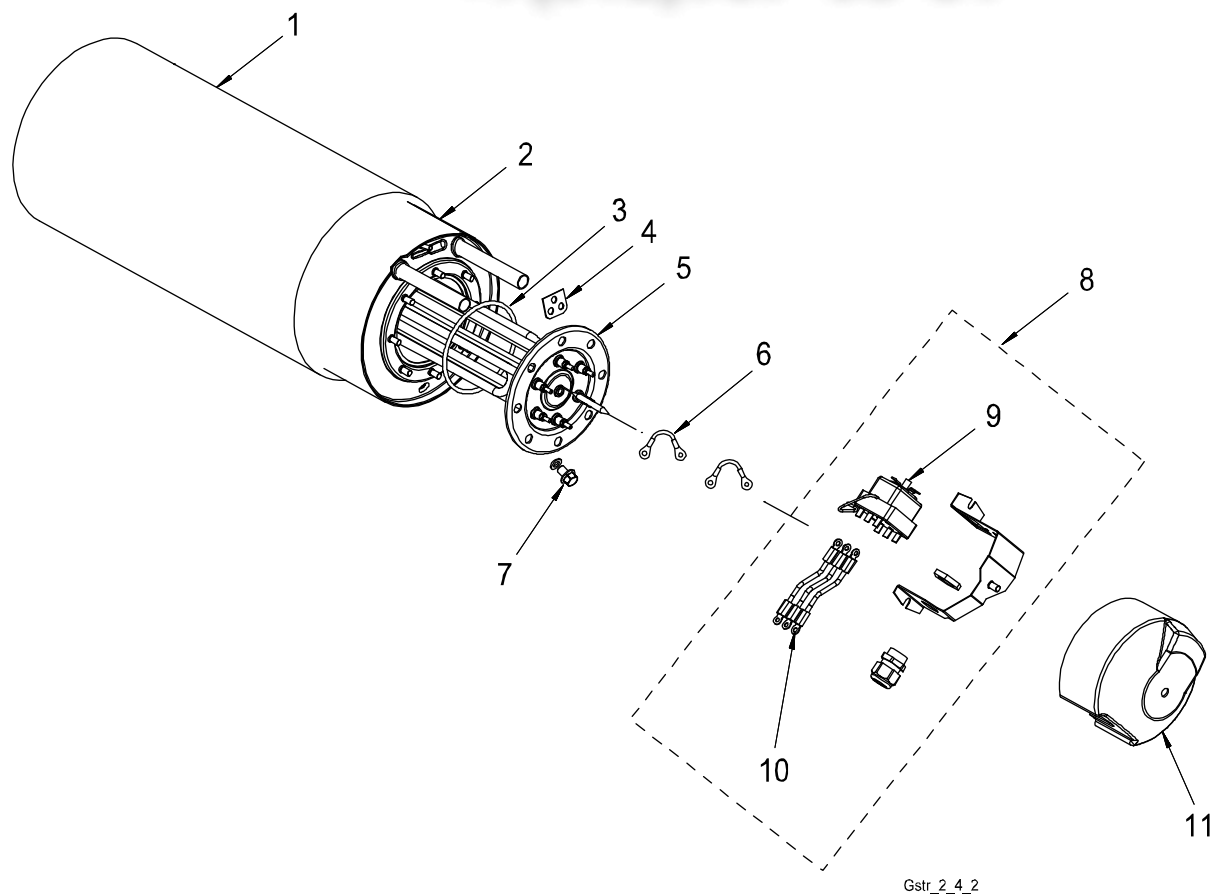

Booster heater (Option)			
Pos	WD no.	Description	Comment
	WD01163.52	Booster heater 3kW	
1	WD809.0903	* Heat insulation booster heater	
2	WD01162.04	* Container booster heater (E)	
3	WD719.1090	* O-ring	
4	WD44203.31	* Attachment temp.sensor	
5		* Element	See the machine's wiring diagram
6	WD670.8240	* Cable bridge	
7	WD700.2501	* Collar screw + Gasket	
8	WD302113.02	* Overheating protection tank element (200-230V & 400-415V), cpl	
9		** Overheating protection	See the machine's wiring diagram
10	WD670.8245	** Coupling conductor	
11	WD301321.31	Protection cover	

Electric cubicle			
Pos	WD no.	Description	Comment
1		Panelcard ESP	See the machine's wiring diagram
2	WD702.1205	Lock washer	
3	WD700.0608	Screw	
4		Temp.sensor	See the machine's wiring diagram
5		Pressure switch, gold	See the machine's wiring diagram
6	WD04196.31	Pressure switch attachment	
7		Fieldbreaker switch	See the machine's wiring diagram
7		Fieldbreaker switch (Option)	See the machine's wiring diagram
8		CPU card ESP	See the machine's wiring diagram
9		Computer card ESP	See the machine's wiring diagram
10	WD702.2015	Distance nut	
11	WD51476114	Cable screw polyamid	
12	WD51476534	Locking nut polyamid	
13	WD702.2207	Distance tube	
14	WD700.1603	Locking nut	
15	WD301794.31	Defence to panelcard	
16	WD718.0724	Plastic nut	
17	WD51402612	Plastic holder	
18	WD67182111	Cable to front plate	
19	WD719.0310	Hose	L=0,8m

1.11 Coupling incoming water (WD6 & WD7 with break tank)

+7(812)987-08-81

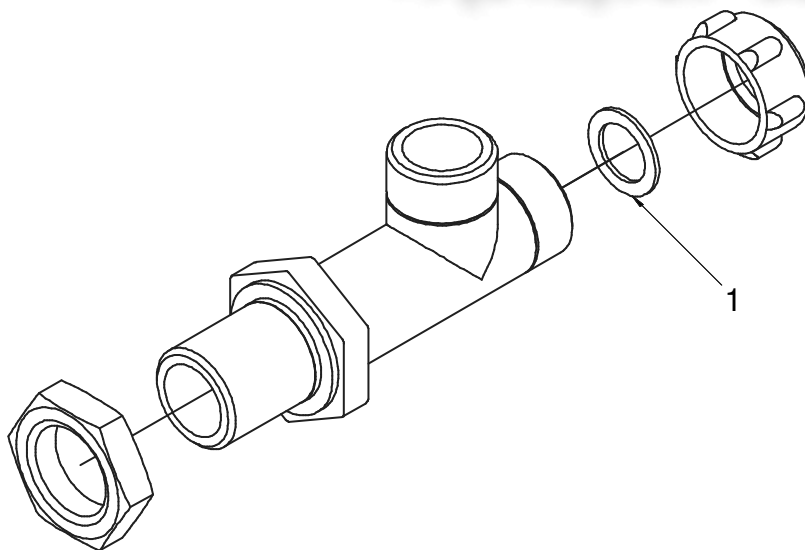

47481

Spare parts

Coupling incoming water (WD6 & WD7 with break tank)			
Pos	WD no.	Description	Comment
	WD47481.31	Coupling incoming water	
1	WD701.0122	* Gasket	

1.12 Valve package (WD-6C & WDS & WD7 without hood lift)

+7(812)987-08-81

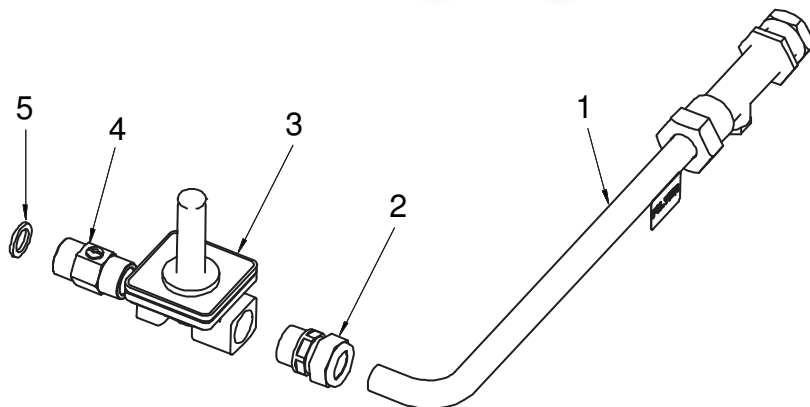

301425

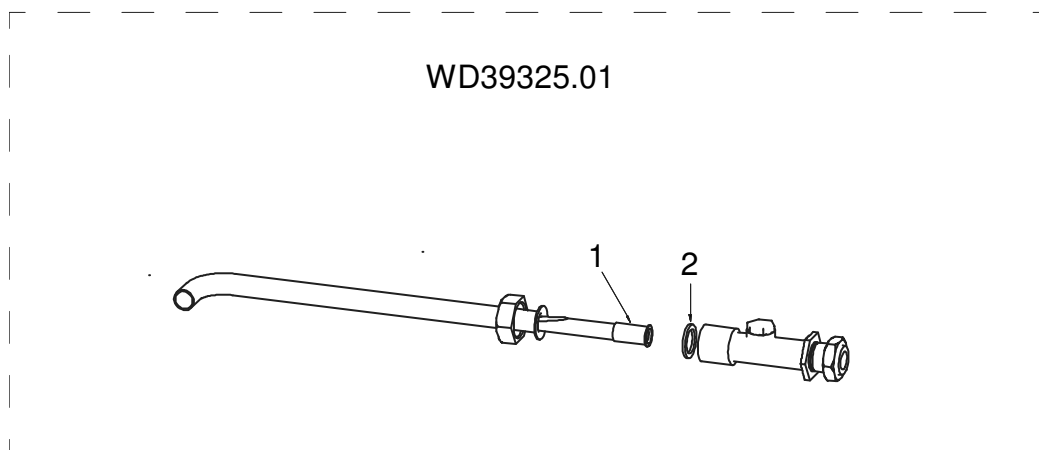

Valve package (WD-6C & WD6 & WD7 without pod ii fi)			
Pos	WD no.	Description	Comment
	WD301425.01	Valve package	
1	WD39325.01	* Incoming water connection, cpl	See below
2	WD705.0915	* Coupling with O-ring	
3		* Solenoid valve	See the machine's wiring diagram
4	WD709.0809	* Ball valve	
5	WD701.0122	* Gasket	
	WD39325.01	Incoming water connection	item 1 above
1	WD40301.01	* Strainer with supporting housing	
2	WD701.0123	* Gasket	

1.13 Valve package (WD-6 & WD-7 with hood) & with breaktank

+7(812)987-08-81

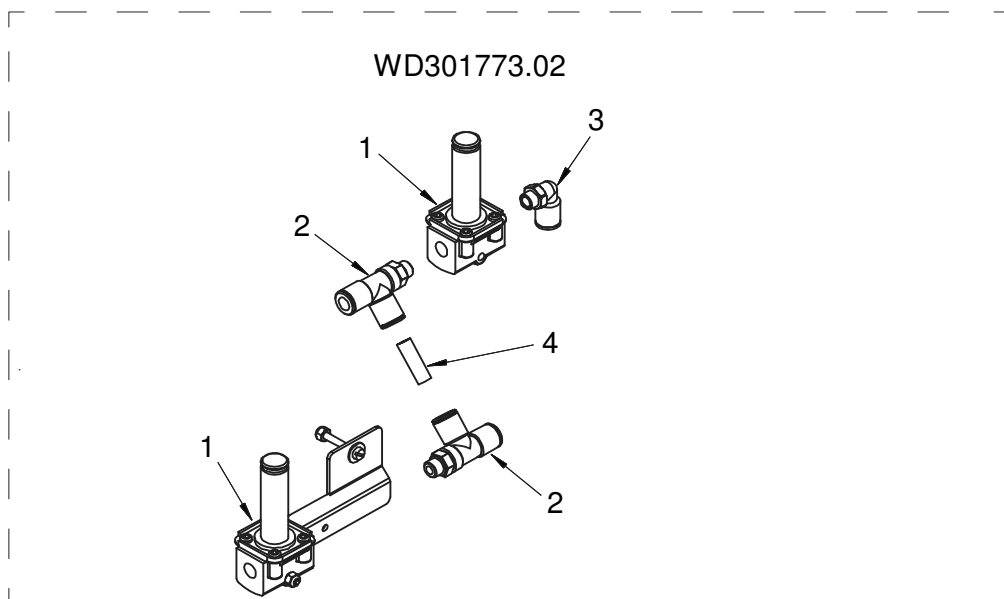
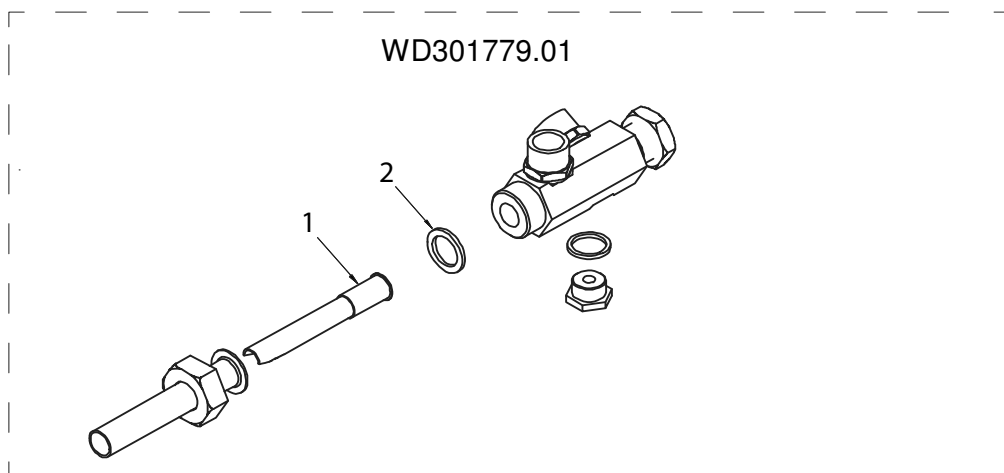
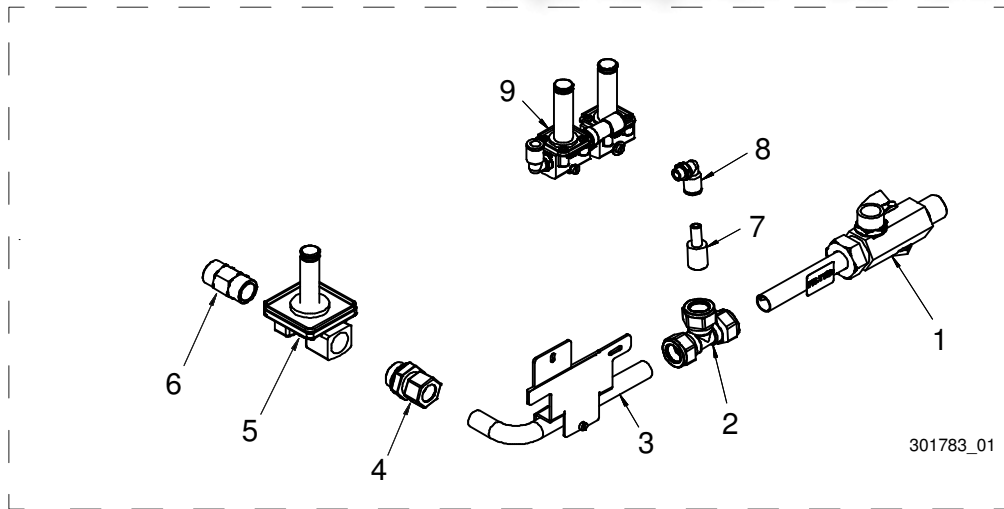

Valve package (WD-6 & WD-7 with hood lift & with break tank)			
Pos	WD no.	Description	Comment
	WD301783.01	Valve package	
1	WD301779.01	* Incoming water connection, cpl	See below
2	WD705.2205	* T-coupling	
	WD705.0420	* Clamping sleeve	
	WD705.0315	* Nut	
3	WD46778.31	* Pipe	
4	WD705.0915	* Coupling with O-ring	
5		* Solenoid valve	See the machine's wiring diagram
6	WD709.0809	* Ball valve	
7	WD46928.31	* Connection valve package	
8	WD706.0915	* L-coupling	
9	WD301773.02	* Valve package, cpl	See below
	WD301779.01	Incoming water connection, cpl	item 1 above
1	WD40301.01	* Strainer with supporting housing	
2	WD701.0123	* Gasket	
	WD301773.02	Valve package, cpl	item 9 above
1		* Solenoid valve	See the machine's wiring diagram
2	WD706.0927	* T-coupling	
3	WD706.0915	* L-coupling	
4	WD46765.31	* Hose	L=35

1.14 Valve package (WD-6 & WD-7 with hood)

+7(812)987-08-81

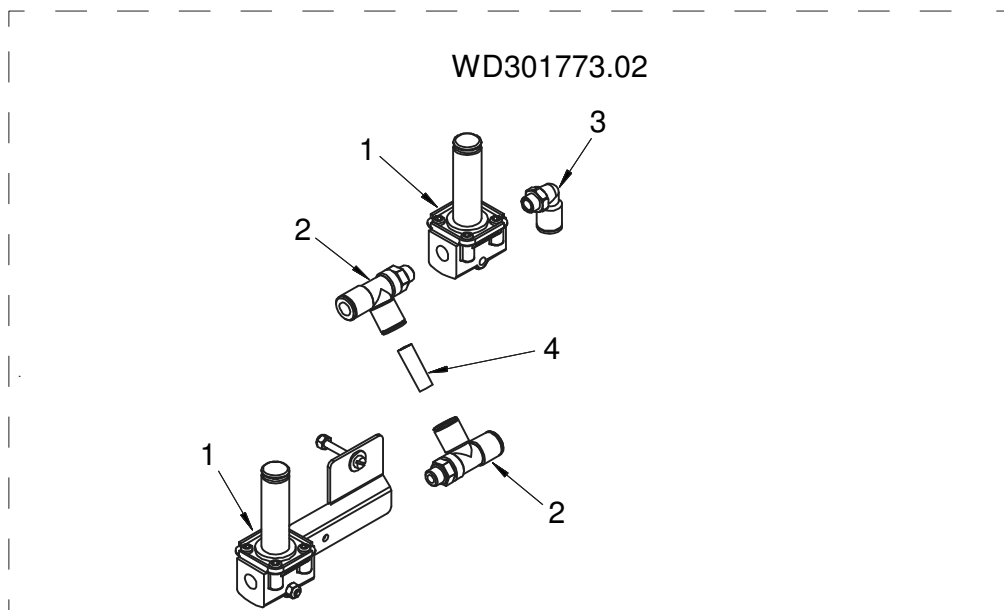
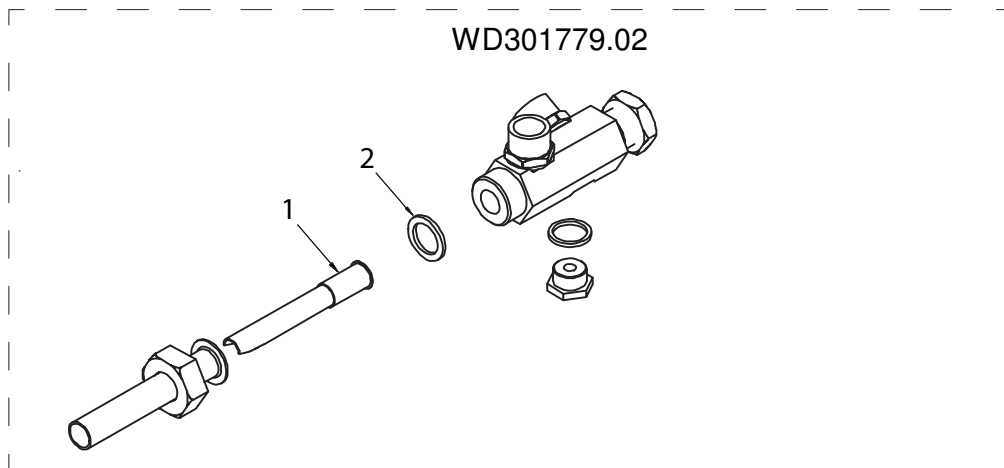
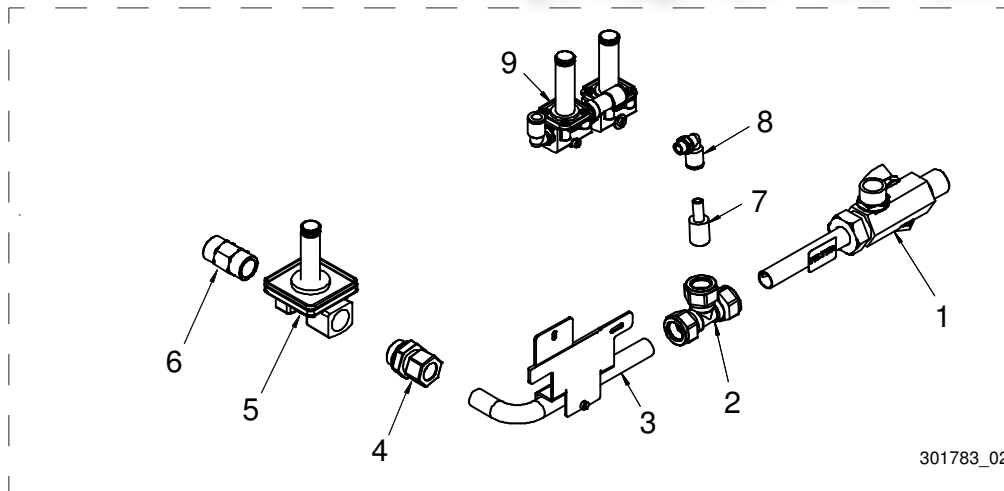

Valve package (WD-6 & WD-7 with hood lift)			
Pos	WD no.	Description	Comment
	WD301783.02	Valve package	
1	WD301779.02	* Incoming water connection, cpl	See below
2	WD705.2205	* T-coupling	
	WD705.0420	* Clamping sleeve	
	WD705.0315	* Nut	
3	WD46778.31	* Pipe	
4	WD705.0915	* Coupling with O-ring	
5		* Solenoid valve	See the machine's wiring diagram
6	WD709.0809	* Ball valve	
7	WD46928.31	* Connection valve package	
8	WD706.0915	* L-coupling	
9	WD301773.02	* Valve package, cpl	See below
	WD301779.02	Incoming water connection, cpl	item 1 above
1	WD40301.01	* Strainer with supporting housing	
2	WD701.0123	* Gasket	
	WD301773.02	Valve package, cpl	item 9 above
1		* Solenoid valve	See the machine's wiring diagram
2	WD706.0927	* T-coupling	
3	WD706.0915	* L-coupling	
4	WD46765.31	* Hose	L=35

1.15 Booster pump with breaktank (option)

+7(812)987-08-81

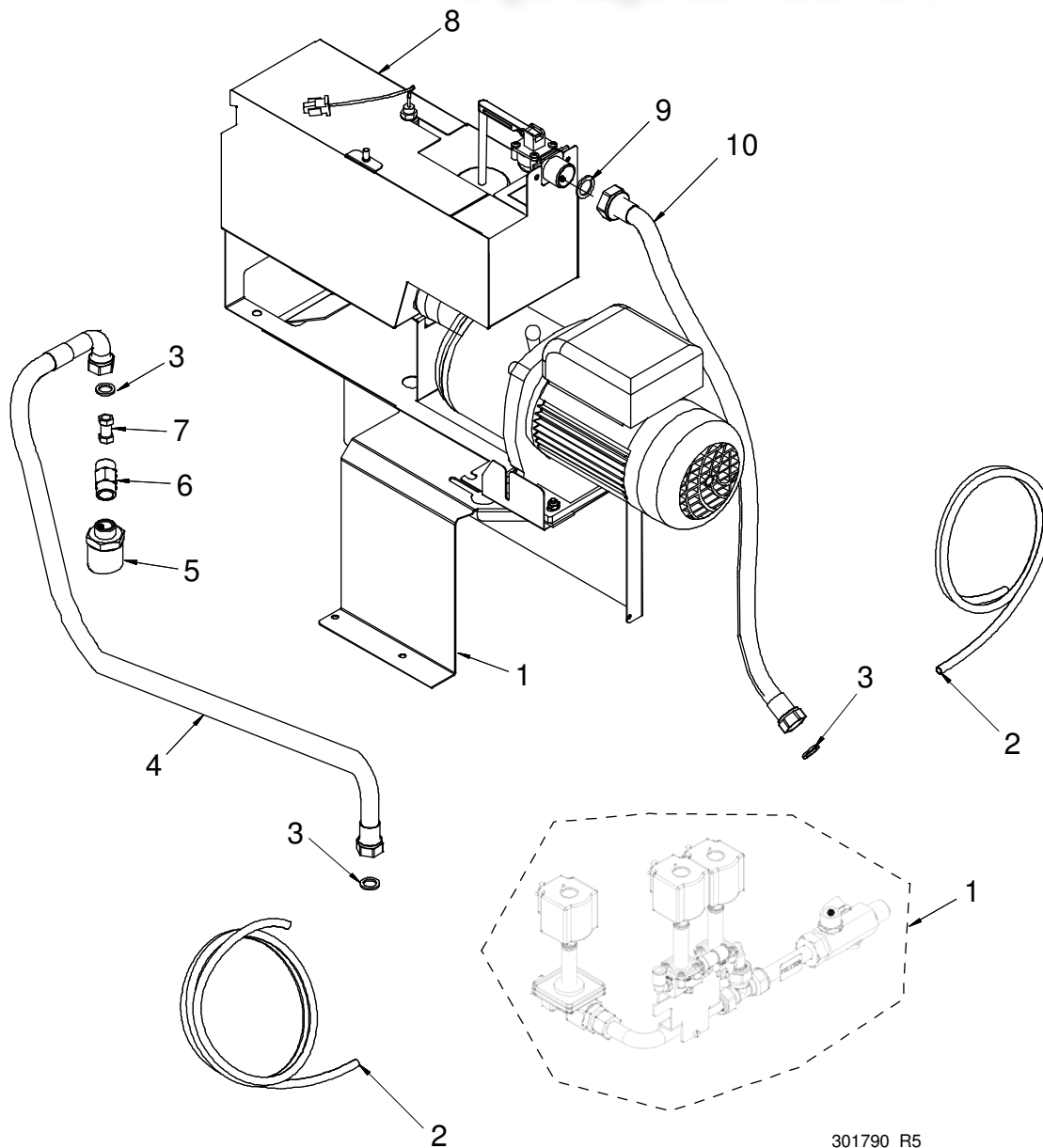

301790_R5

Booster pump with breaktank (option)			
Pos	WD no.	Description	Comment
1		Incoming water & valve package	Depending on what the machine is equipped with. See separate section.
2	WD737.0421	Nylon tube	
3	WD701.0122	Gasket	
4	WD47139.01	Steel braided hose	
5	WD706.0813	Hexagon nipple	
6	WD709.0809	Ball valve	Not on machines with automatic hood lift.
7	WD709.1305	Non return valve	
8		Breaktank, cpl	See separate section
9	WD701.0123	Gasket	
10	WD47153.01	Steel braided hose	
11	WD300187.31	Attachment booster pump	

1.16 Breaktank (option)

vsezip.ru

+7(812)987-08-81

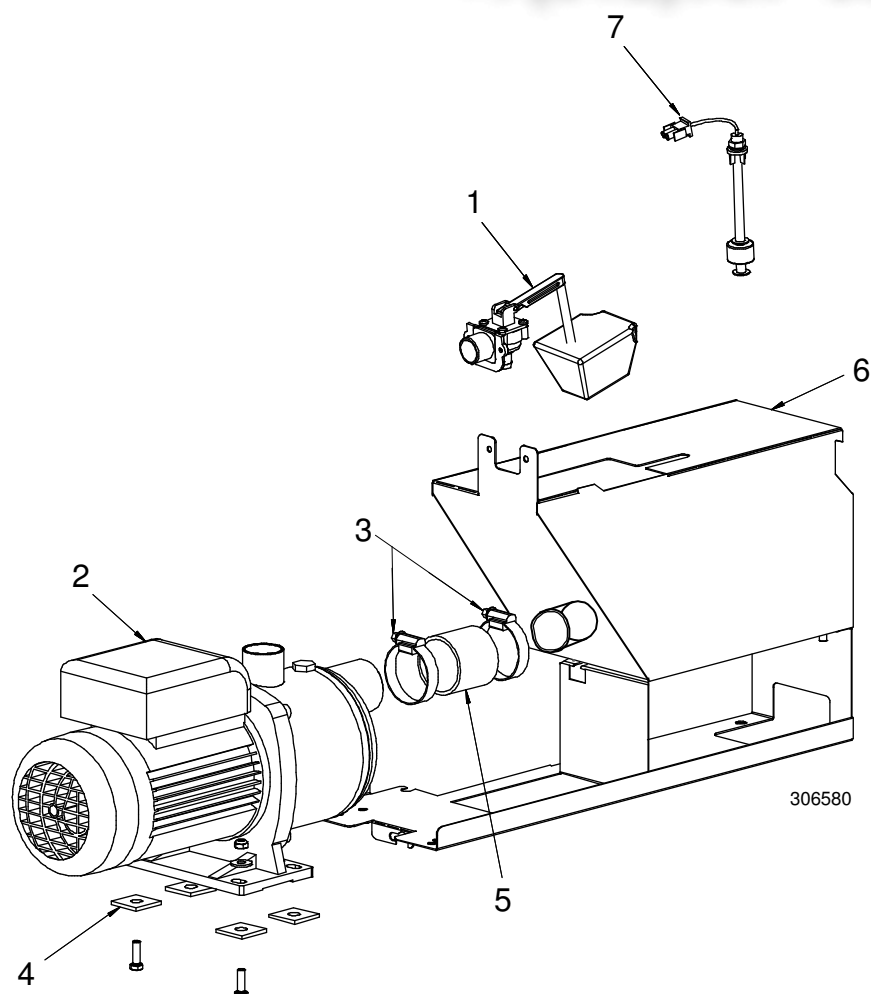

Breaktank (option)			
Pos	WD no.	Description	Comment
1	WD709.4021	Float	
2		Pump 1HM	See the machine's wiring diagram
3	WD714.0108	Hose clamp	
4	WD719.1330	Rubber foot	
5	WD48107.31	Rubber connection breaktank pump	
6	WD306584.01	Tank cpl, Break tank	
7		Level guard	See the machine's wiring diagram

1.17 Booster pump without break tank (option)

+7(812)987-08-81

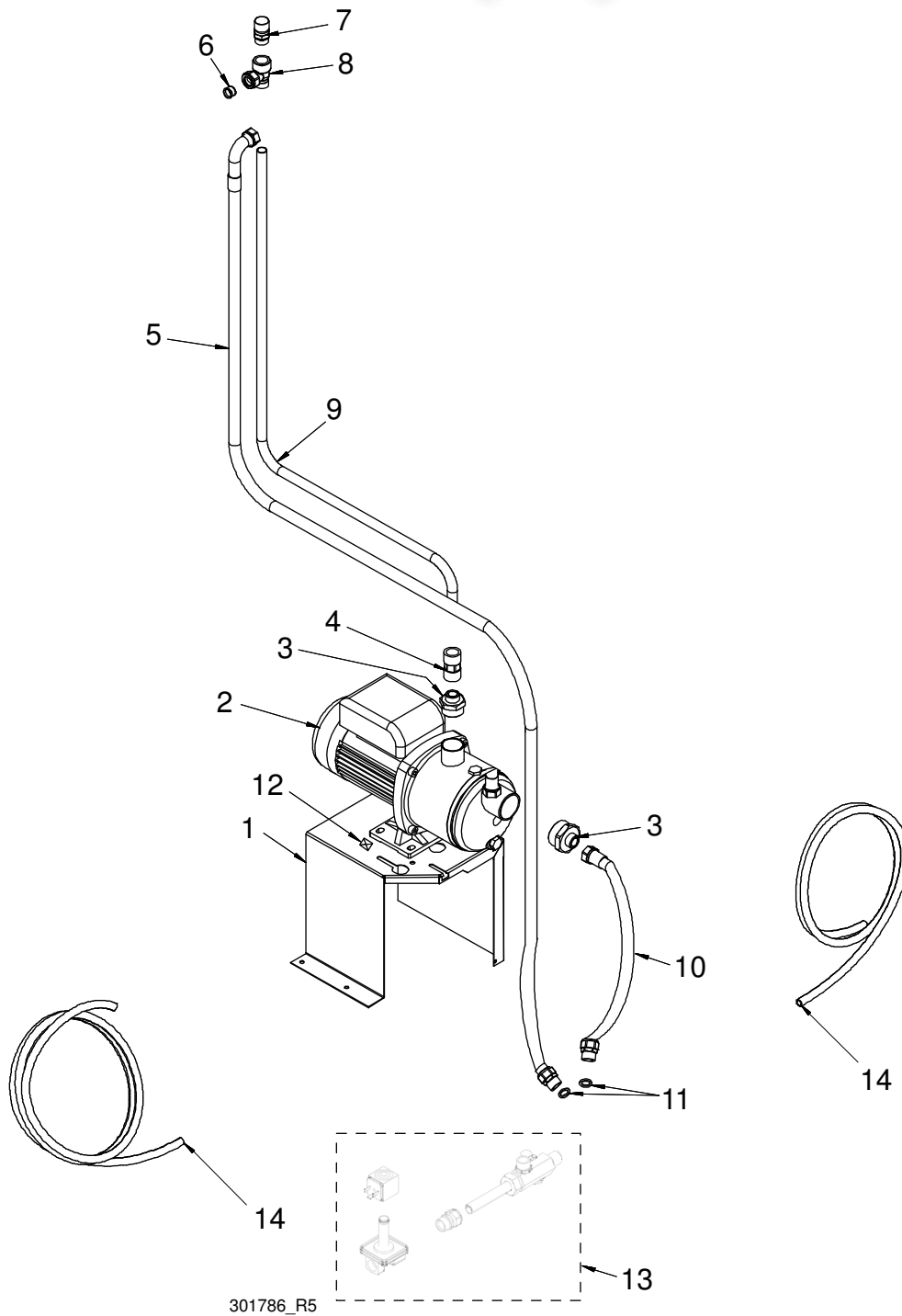

Booster pump without breaktank (optional)			
Pos	WD no.	Description	Comment
1	WD300187.31	Attachment booster pump	
2		Pump 1HM	See the machine's wiring diagram
3	WD706.0813	Hexagon nipple	
4	WD709.1305	Non return valve	
5	WD717.0401	Hose inlet	L=1500
6	WD709.0820	Reducing	
7	WD709.1506	Vacuum valve	
8	WD705.2704	Coupling	
	WD705.0420	* Clamping sleeve	
	WD705.0315	* Nut	
9	WD46602.31	Pipe vacuum valve	
10	WD400199.01	Hose	L=510
11	WD701.0122	Gasket	
12	WD719.1330	Rubber foot	
13		Incoming water & valve package	Depending on what the machine is equipped with. See separate section.
14	WD737.0421	Nylon hose	Hoodlift

1.18 Emptying pump (option) vsezip.ru

+7(812)987-08-81

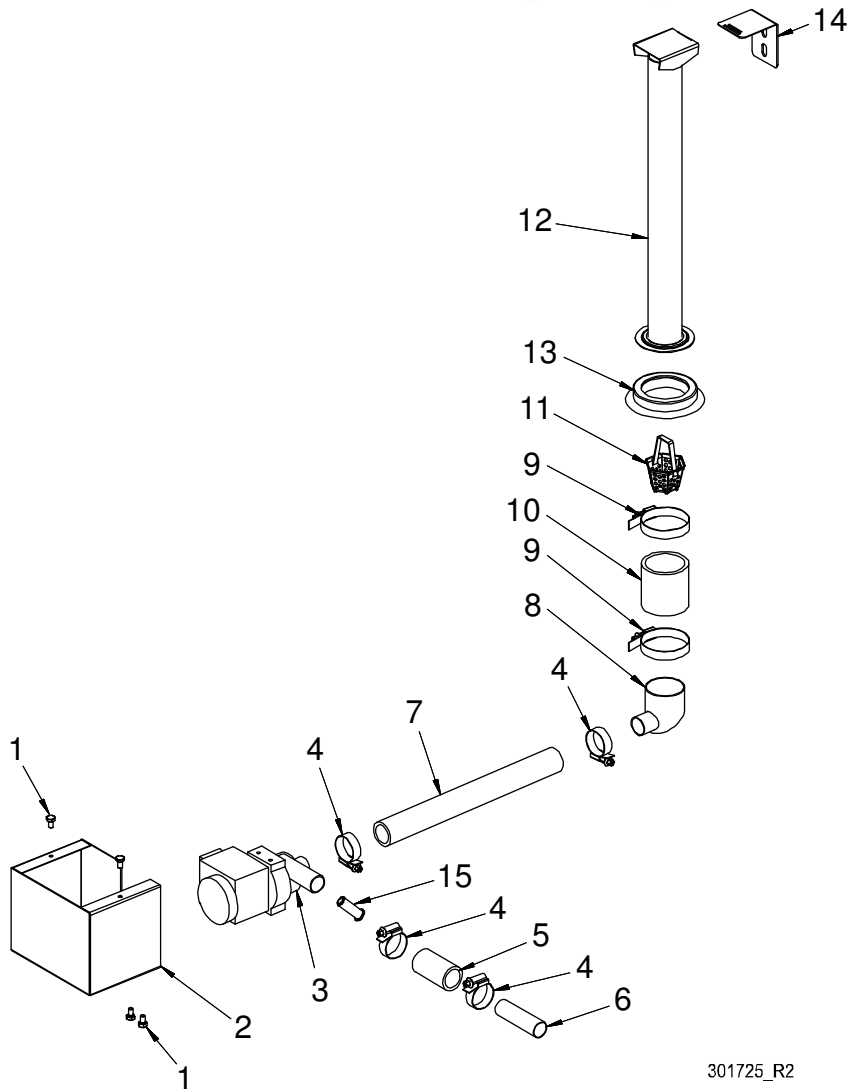

301725_R2

Emptying pump (option)			
Pos	WD no.	Description	Comment
1	WD700.0111	Screw	
2	WD300636.31	Cover emptying pump	
3		Emptying pump	See the machine's wiring diagram
4	WD714.0106	Hose clamp	
5	WD717.0125	Radiator hose	L=60mm
6	WD04703.31	Pump connection empt.pump	
7	WD717.0125	Radiator hose	L=290mm
8	WD04224.01	Drain connection empt.pump	
9	WD714.0110	Hose clamp	
10	WD717.0150	Radiator hose	L=60mm
11	WD44952.01	Outlet strainer	
12	WD301029.01	Level pipe	
13	WD719.4036	Level pipe sealing	
14	WD45983.31	Attachment level pipe	
15	WD705.0103	Supporting sleeve	

1.19 Backflow prevention device (option)

+7(812)987-08-81

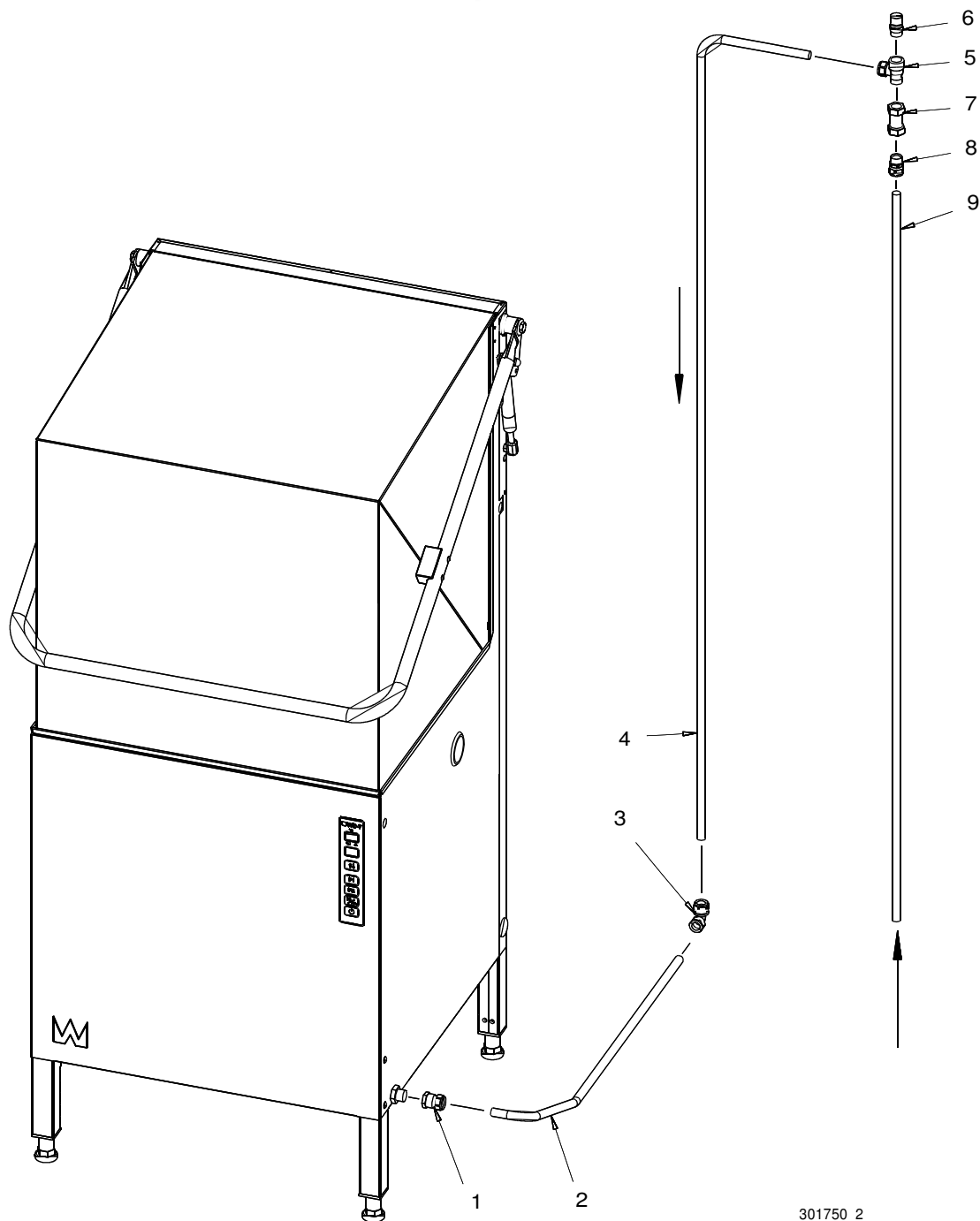

Backflow prevention device (option) vsezip.ru			
Pos	WD no.	Description	Comment
1	WD705.1008	Coupling	
	WD705.0420	* Clamping sleeve	
	WD705.0316	* Nut	
2	WD31711.75	Pipe	
3	WD705.1607	Coupling, angled	
	WD705.0420	* Clamping sleeve	
	WD705.0316	* Nut	
4	WD31712.75	Pipe	
5	WD705.2703	T-coupling	
	WD705.0420	* Clamping sleeve	
	WD705.0316	* Nut	
6	WD709.1506	Vacuum valve	
7	WD709.1305	Non return valve	
8	WD705.0912	Coupling	
	WD705.0420	* Clamping sleeve	
	WD705.0316	* Nut	
9	WD40249.75	Pipe	

1.20 Rebuilding kit 460 basket (option)

+7(812)987-08-81

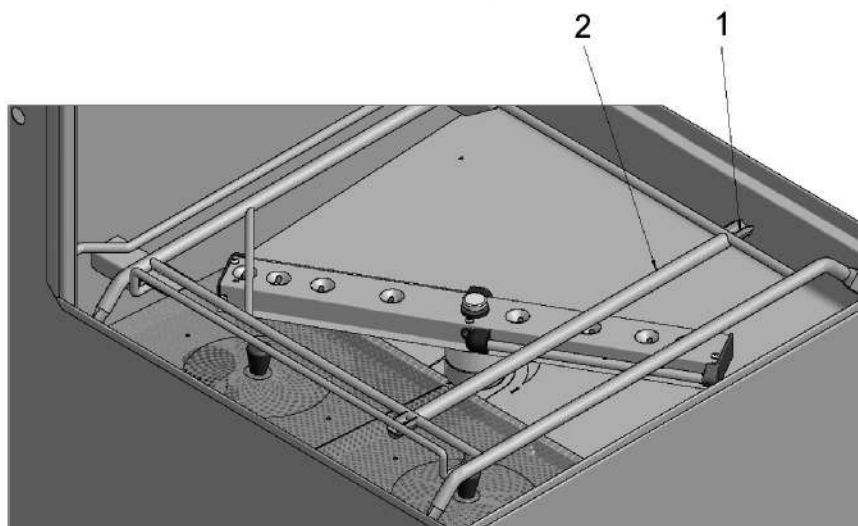

741,7011r1

Rebuilding kit 460 basket (option)			
Pos	WD no.	Description	Comment
	WD741.7011	Rebuilding kit 460 basket	
1	WD46633.31	* Attachment support 400 basket	
2	WD46626.31	* Support basket frame rail 400 basket	

Heat recovery by the exhausted steam (option)			
Pos	WD no.	Description	Comment
1	WD303033.31	Outer plate steam cap	
2	WD303030.31	Mounting plate fan	
3		Fan RFE	See the machine's wiring diagram
4	WD918.0115	Pipe PEX	L=1 m
5	WD810.0907	Condensing battery	
6	WD46748.31	Anchor plate condensing battery	
7	WD27825.01	Box steam cap	
8	WD46802.31	Cover plate	
9	WD705.0914	Coupling	
	WD705.0420	* Clamping sleeve	
	WD705.0315	* Nut	
10	WD705.0104	Supporting sleeve	
11	WD719.5026	Tube EPDM+RFR	L=2000 mm
12	WD719.1219	Conduit entry	
13	WD27802.31	Rear plate	
14	WD705.1905	Coupling angled	
	WD705.0420	* Clamping sleeve	
	WD705.0315	* Nut	
15	WD305297.31	Gasket	
16	WD44716.31	Gasket	

1.22 Heat recovery by the drain (water option)

+7(812)987-08-81

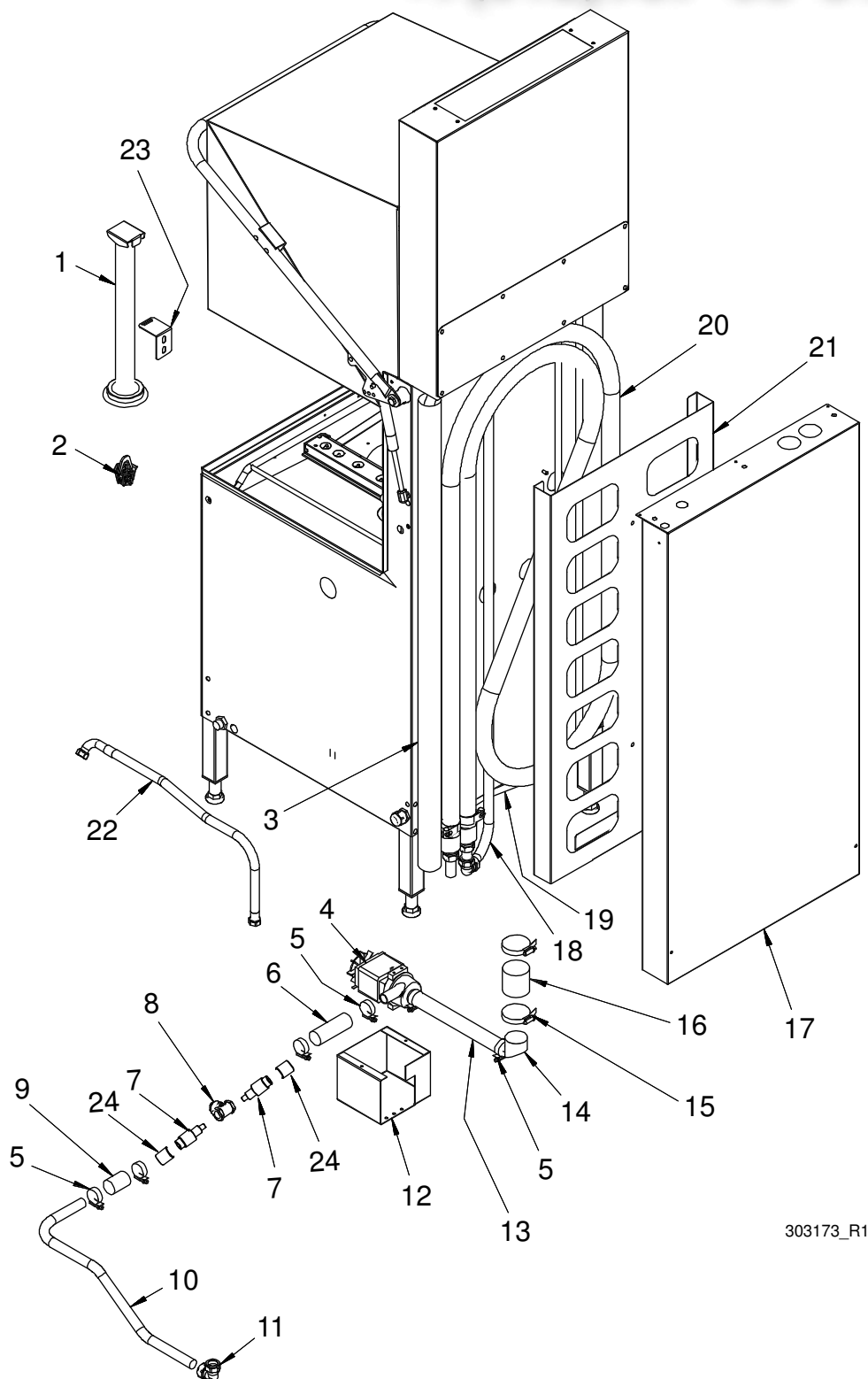

303173_R1

Heat recovery by the drain water (option)			
Pos	WD no.	Description	Comment
1	WD301029.01	Level pipe	
	WD719.4036	* Level pipe sealing	
2	WD44952.01	Outlet strainer	
3	WD726.0850	Pipe without muff	L=1260mm
4		Drain pump	See the machine's wiring diagram
5	WD714.0107	Hose clamp	
6	WD717.0125	Radiator hose	L=130mm
7	WD706.0803	Hose nipple	
8	WD709.0561	Flap non return valve	
9	WD717.0125	Radiator hose	L=50mm
10	WD46760.31	Pipe drain pump	
11	WD705.1207	Coupling	
	WD705.0323	* Clamping sleeve	
	WD705.0322	* Nut	
12	WD300636.31	Cover emptying pump	
13	WD717.0125	Radiator hose	L=270mm
14	WD04224.01	Drain connection emptying pump	
15	WD714.0111	Hose clamp	
16	WD717.0150	Radiator hose	L=60mm
17	WD27802.31	Rear plate	
18	WD303013.31	Pipe drain heat recover	
19	WD719.5026	Tube EPDM+RFR	L=2000mm
20	WD303008.01	Heat recovery, cpl	
	WD714.0603	* Hose clamp	
	WD40058.31	* Distribution nipple	
	WD303064.01	* Heat recovery	
	WD705.0917	* Coupling	
	WD705.0323	* Clamping sleeve	
	WD705.0322	* Nut	
21	WD303191.31	Attachment	
22	WD719.5025	Tube	L=800mm
23	WD45983.31	Attachment level pipe	
24	WD706.0503	Muff	

1.23 Pump 1295

vsezip.ru

+7(812)987-08-81

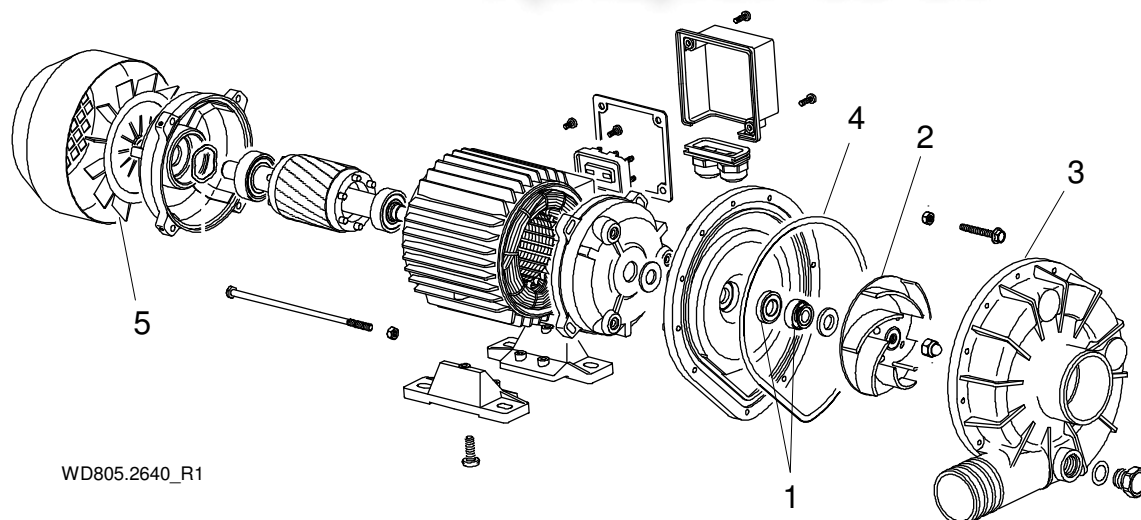

WD805.2640_R1

Pump 1295			
Pos	WD no.	Description	Comment
	WD301494.01	Pump 230/400V 50Hz, Kpi	
	WD805.2640B	Pump 230/400V 60Hz	
	WD805.2640C	Pump 255/440V 60Hz	
	WD805.2640D	Pump 230V 50Hz	
	WD805.2640E	Pump 200V 50Hz	
	WD805.2640F	Pump 200V 60Hz	
	WD805.2640G	Pump 277/480V 60Hz	
1	WD805.2554	* Sealing	
2	WD805.2643	* Impeller	50Hz
2	WD805.2643F	* Impeller	60Hz
3	WD805.2611	* Pump house	
4	WD805.2555	* O-ring	50Hz
5	WD805.2552	* Fan	