

Зип Общепит

vsezip.ru
Арач
+7(812)987-08-81

**SPARE PARTS CATALOGUE
ERSATZTEILKATALOG
CATALOGUE PIECES DETACHEES
CATALOGO PARTI RICAMBIO
CATALOGO DE PIEZAS DE RECAMBIO
CATALOGO PEÇAS DE REPOSICAO**

AC 800

04-04-2013

Зип Общепит

vsezip.ru

+7(812)987-08-81

Tav.1: Carrozzeria
Tav.2: Impianto elettrico
Tav.3: Componenti in vasca
Tav.4: Circuito di lavaggio
Tav.5: Circuito di risciacquo
Tav.6: Lance di lavaggio
Tav.7: Pompa di lavaggio
Tav.8: Pompa di scarico

Tab.1: Carrocería
Tab.2: Instalación eléctrica
Tab.3: Componentes en cuba
Tab.4: Circuito de lavado
Tab.5: Circuito d'enjuague
Tab.6: Brazos de lavado
Tab.7: Bomba de lavado
Tab.8: Bomba de descarga

Taf.1: Verkleidung
Taf.2: Elektrische Anlage
Taf.3: Bauteile im Waschtank
Taf.4: Spuelschaltung
Taf.5: Nachspuelschaltung
Taf.6: Wascharmee
Taf.7: Spuelpumpe
Taf.8: Laugenpumpe

Tav.1: Machine body
Tav.2: Electrical components
Tav.3: Components in the tank
Tav.4: Washing circuit
Tav.5: Rinsing circuit
Tav.6: Washing arms
Tav.7: Washing pump
Tav.8: Draining pump

Tab.1: Carrosserie
Tab.2: Installation électrique
Tab.3: Composants de cuve
Tab.4: Circuit de lavage
Tab.5: Circuit de rinçage
Tab.6: Bras de lavage
Tab.7: Pompe de lavage
Tab.8: Pompe de vidange

vsezip.ru

+7(812)987-08-81

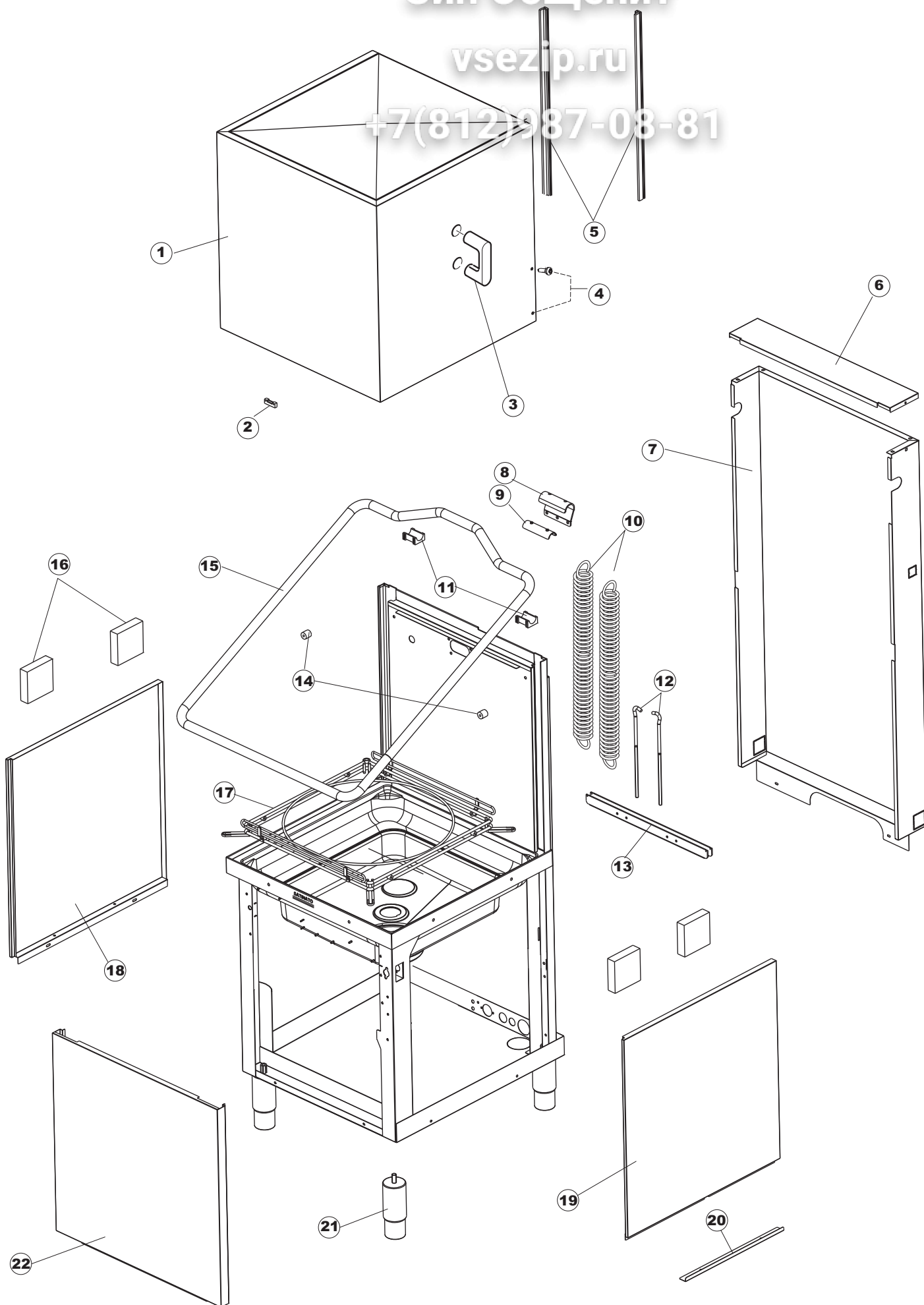

Listino componenti per pagina 1

Зип Общепит

vsezip.ru

(7912)987-08-81

1	80141	GRUPPO CAPPА SQUADRATA COMPLETA COMPLETE HOOD GROUP KOMPLETE HAUBE GRUPPE GROUPE COMPLETE CAPOT GRUPO CAMPANA CUADRADA COMPLETA	
2	927088	MAGNETE PER MICROINTERRUPTORE MAGNET FOR MICROSWITCH MAGNET FÜR MIKROSCHALTER AIMANT POUR MINIRUPTEUR IMAN PARA MICROINTERRUPTOR	
3	926243	PONTICELLO GRIGIO MANIGLIA TIPO CLG. CONVEX TYPE HANDLE, GREY TYPE CLG. STEG, GRIFF GRAU TYP CLG. ARCADE GRIS POIGNEE TYPE CLG. PUENTE GRIS MANIJA TIPO CLG.	
4	80998	VITE PLASTICA M4X6 (DIN933) GOLD SCREW, PLASTIC M4X6 (DIN933) GOLD SCHRAUBE, KUNST. M4X6 (DIN933) GOLD VIS PLASTIQUE M4X6 (DIN933) GOLD TORNILLO PLASTICO M4X6 (DIN933) GOLD	
5	80069	GUIDA CAPPА HOOD DRIVE UAHN GUIDE HOTTE GUIA CAPOT	
6	80638	TUBO PASSACAVI PANNELLO POSTERIORE BACK PANEL OBEREN RÜCKSEITE PANNEAU ARRIERE SUPÉRIEUR PANEL TRASERO SUPERIOR	
7	80162	PANNELLO RETRO PANEL, REAR PLATTE, HINTEN PANNELLO ARRIERE PANEL TRASERO	
8	80275	SQUADRA BRACKET WINKEL EQUERRE ESCUADRA	
9	80277	SQUADRA BRACKET WINKEL EQUERRE ESCUADRA	
10	926007	MOLLA TRAZ.CAPOTTA f5 100/120/140 SPRING, HOOD TRAZ. f5 100/120/140 SPANNFEDER HAUBE f5 100/120/140 RESSORT TRACT.CAPOT f5 100/120/140 MUELLE TRACC. CAPOTA f5 100/120/140	
11	80190	SQUADRA SUPP.MANIGLIONE BRACKET, FOR HANDLE SUPP. WINKEL, HALTER FÜR GRIFF EQUERRE SUPP.POIGNEE ESCUADRA SOP. MANIJA	
12	926009	GANCIO REGOLAZIONE MOLLA 100/120/140 HOOK, ADJUST.SPRING 100/120/140 HAKEN, FEDERREGUL. 100/120/140 CROCHET REGLAGE RESSORT 100/120/140 GANCHO REGULACION MUELLE 100/120/140	
13	80023	SQUADRA BRACKET WINKEL EQUERRE ESCUADRA	
14	80105	PARACOLPI CAPOT SHOCK-ABSORBER FOR CAPOT PUFFER FÜR DURCHSCHUBSPÜLAUTOM. PARE-CHOCS CAPOT GUARDAGOLPES CAPOT	
15	80027	MANIGLIONE RIVER HANDLE, RIVER GRIFF, RIVER POIGNEE RIVER MANIJA RIVER	

16	41042	SPESSORE ADESIVO PANNELLO LATERALE LP STICKY DOOR SIDE THICKNESS KLEBENPER SCHLEGER TEMPON ADHÉSIF ESPEMORE ADHESIVO PANELES LATERALES LP	
17	80240	TELAIO PORTACESTO CAPOT D1000 FRAME, RACK-HOLDER CAPOT D1000 RAHMEN, KORBHALTER DURCHSCHUBSPÜL AUTOM. D1000 CHASSIS PORTE-CASER CAPOT D1000 BASTIDOR PORTACESTA CAPOT D1000	
18	80071	PANNELLO LATERALE SX PG FINIT PANEL, SIDE LH PG PLATTE, SEITL. LINKS PG MASCHINENF. PANNEAU LATERAL GAUCHE PG FINI PANEL LATERAL IZDA PG ACAB.	
19	80072	PANNELLO LATERALE DX PG FINITO PANEL, SIDE RH PG PLATTE, SEITL. RECHTS PG MASCH. PANNEAU LATERAL DROITE PG FINI PANEL LATERAL DCHA PG ACABADO	
20	80078	SQ. FISSAGGIO SOTTOPIANI GOLD PG FINITO BRACK., UNDER-SHELVES FIX. GOLD PG FINISHED BEF.WINKEL, UNTERABLAGEFEL.GOLD PG MASCHINENFERTIG EQ. FIXATION SOUS-ETAGERES GOLD PG FINI ESC. FIJACION APOYOS SUPERFICIES GOLD PG	
21	926117	PIEDE REGOLABILE X CAPOTT.3LINEA FOOT, ADJUST. X CAPOTT.3LINE VERSTELLFUSS X HAUB.3LEIT. PIED REGLABLE POUR CAPOT.3LIGNE PATA REGULABLE X CAPOTA 3LINEA	
22	69100	PANNELLO ANTERIORE COMANDI COMPLETO COMPLETE FRONT PANEL VORDER-PANEEL KOMPLET PANNEAU AVANT COMPLET PANEL DELANTERO COMADI COMPLETO	

vsezip.ru

+7(812)987-08-81

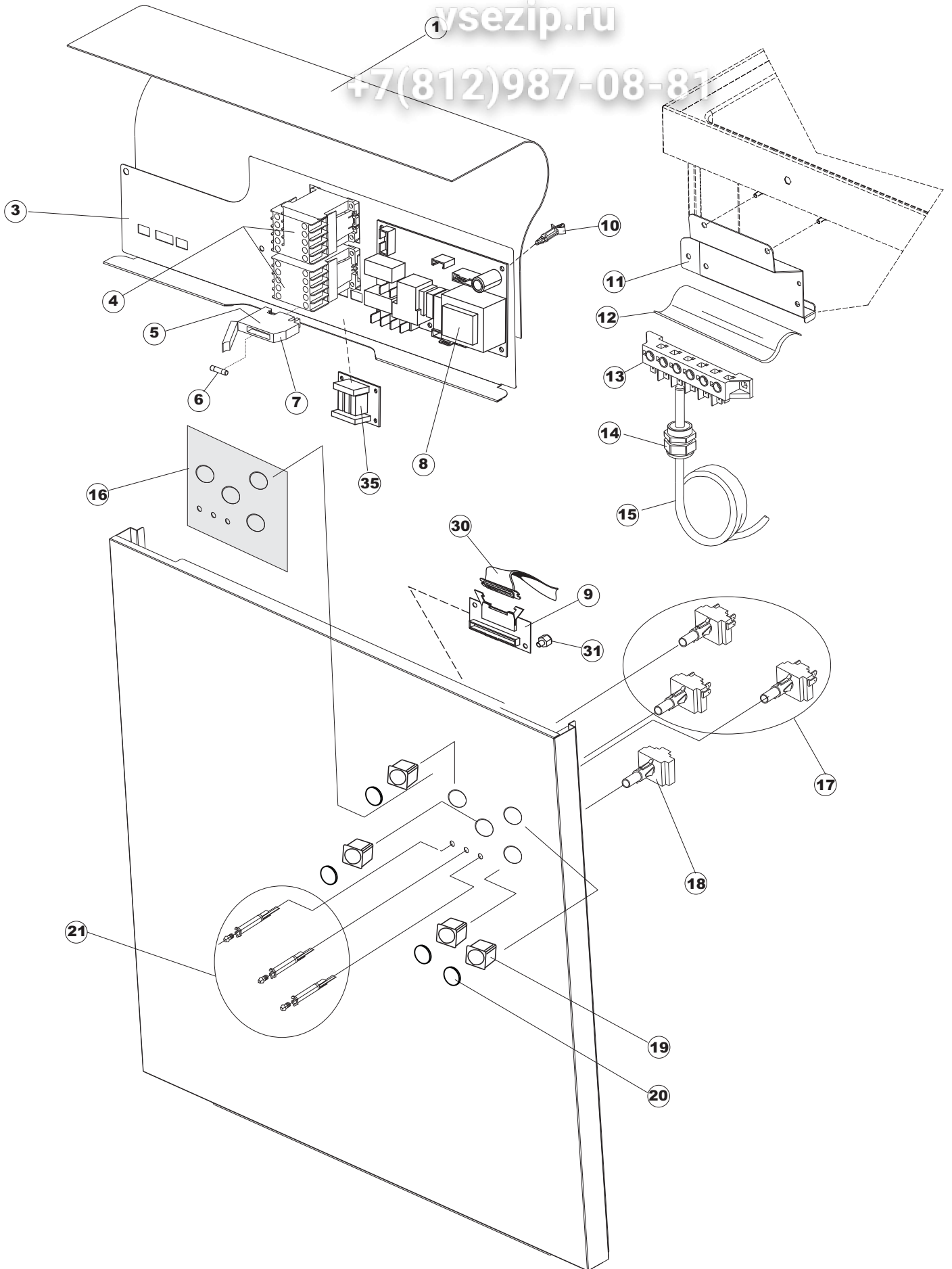

Listino componenti per pagina 2

Зип Общепит

1	214086	PROTEZ.EL.TELA TRASP.463/503 EL.PROTECTION,TRASP.CANVAS 463/503 EL.SCHUTZ,DURCHS.GEWEBE 463/503 PROTECT.EL.TOILE TRANSP.463/503 PROT. EL. TELA TRANSP. 463/503 VER COD. 214108	
3	69401	PANNELLO IMPIANTI PANEL INSTALACIÓN	
4	73350	CONTATTORE 230/50-60HZ CONTACTOR 230-50/60HZ KONTAKT-GEBER 230-50/60HZ CONTACTEUR 230-50/60HZ CONTACTOR	
5	H.228048	* CHIUSURA PORTA-FUSIBILE * CLAMPING FOR FUSE-HOLDER * SICHERUNGSTRAGER-VERSCHLUSS * COUVERTURE PORTE-FUSIBLE * CIERRE PORTAFUSIBLE	
6	228010	FUSIBILE 5X20 4A FAST FUZE 5X20 4A FAST SICHERUNG 5X20 T4A FUSIBLE5X20 T4A FUSIBLE 5X20 T4A RETARDADO 250V	
7	H.228047	* PORTA-FUSIBILE * FUSE-HOLDER *SICHERUNGSTRAGER * PORTE-FUSIBLE * PORTAFUSIBLE	
8	215034-5	SCHEDA ELETTRONICA MAIN BOARD KARTE CARTE ELECTRONIQUE TARJETA GET50	
9	215037	INTERFACCIA MECCANICA MECHANICAL INTERFACE	
10	CWP2	PIEDINI SUPPORTO SCHEDA ELET.(ART.DRA6A) FEET, ELECTR.CARD SUPPORT(ART.DRA6A) STÜTZFÜSSE FÜR PLATINE (ART.DRA6A) PIEDS SUPPORT FICHE ELECTR.(ART.DRA6A) PATAS SOPORTE TARJETA ELECT. (ART.DRA6A)	
11	69063	SUPPORTO MORSETTIERA SUPPORT TERMINAL UNTERSTÜTZUNG TERMINAL TERMINAUX DE SOUTIEN SOPORTE BORNERO	
12	214088	PROTEZ.ELETTR.TRASP.CL.3 EL.PROTECTION,TRANSP.CL.3 EL.SCHUTZ,TRANSP.KL.3 PROTECT.ELECTR.TRANSP.CL.3 PROTECCION ELECTR. TRANSP. CL. 3	
13	220011	* MORSETTIERA 5.POLI + TERRA FV.122 * TERMINAL BOARD, 5-POLES + EARTH FV.122 * KLEMMENBRETT, 5-POLIG + ERDUNG FV.122 * PLAQUE A BORNE 5POLES + TERRE FV.122 * BORNERO 5. POLOS + TIERRA FV. 122	
14	929103	PRESSACAVO PG16 PASSO (BER 4716) CABLE GLAND PG16 PITCH (BER 4716) KABELSCHELLE PG16 STEIGUNG (BER 4716) SERRE CABLE PG16 PAS (BER 4716) SUJETA-CABLE PG16 PASO (BER 4716)	
15	69803	CAVO ALIMENTAZIONE POWER CABLE ELEKTRISCH KABEL CÂBLE ÉLECTRIQUE	
16	69999	POLIESTERE	

17	208010	DEVIATORE DOPPIO - 35/40/50 SWITCH, DOUBLE - 35/40/50 ABLENKER, DOPPELT - 35/40/50 COMMUTATEUR DOUBLE - 35/40/50 DESVIADOR DOBLE - 35/40/50	
18	226102	STRUTTURA FISSA CM X TASTO ELLITTICO FIX FRAME CM FOR ELLIPTIC.KEY FESTES GESTELL CM FÜR ELLIP.TASTE STRUCTURE FIXE CM POUR TOUCHE ELLIPTIQUE ESTRUCTURA FIJA CM X TECLA ELIPTICA	
19	226126	CORPO PULSANTE GRIGIO RAL7015(D25)) SWITCHCASE DRUCKTASTENGEHAEUSE CORPS DE BOUTON POUSSOIR CUERPO PULS.	
20	227064	TASTO GOFFRATO GRIGIO SERIE D25 KEY, EMBOSS. GREY SERIES D25 TASTE, GAUFR. GRAU REIHE D25 TOUCHE REPOUSSE GRIS SERIE D25 TECLA GROFRADA GRIS SERIE D25	
21	216029	LAMPADA SPIA TB/06/SQ3 ARANCIO WARNING LAMP, TB/06/SQ3 ORANGE KONTROLL-LAMPE, TB/06/SQ3 ORANGE LAMPE-TEMOIN TB/06/SQ3 ORANGE LAMPARA TESTIGO TB/06/SQ3 NARANJA	
30	80934	CAVO FLAT COMANDI INFERIORI CAPOT CABLE FLAT CAPOT FLACHKABEL CABLE LIAISON CABLE FLAT MANDOS INFERIORES CAPOT	
31	461028	PIEDINO PLAST.SCHEDA 5309AA00XS	
35	215036	SCHEDA ELETTRONICA MAIN BOARD KARTE CARTE ELECTRONIQUE TARJETA CHORROS50 MICRO 644	ST805RUDD

vsezip.ru

+7(812)987-08-81

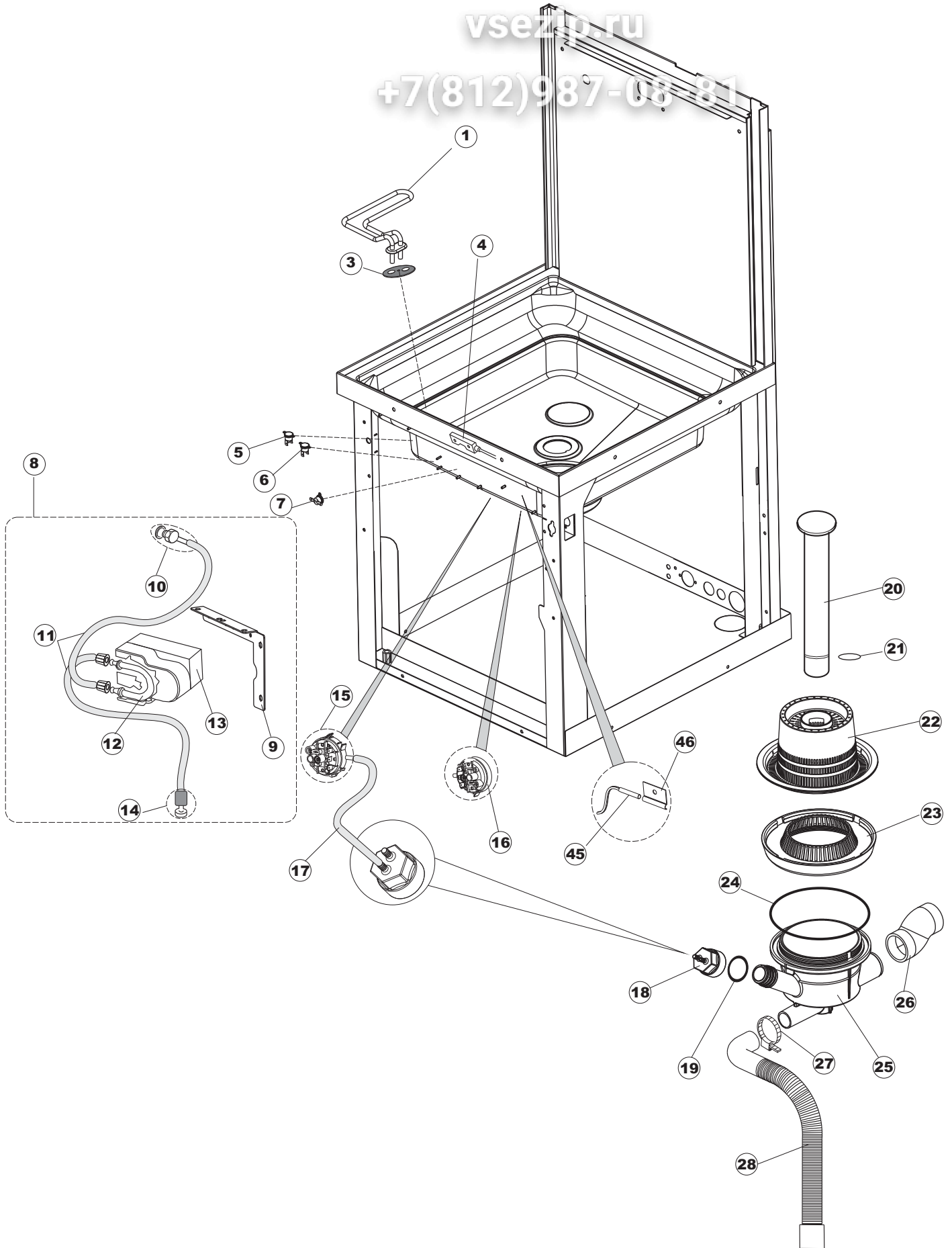

Listino componenti per pagina 3

Зип Общепит

vsezip.ru

(812)987-08-81

1	230112	RESISTENZA V 1400W-230V - LA50 HEATING ELEMENT WIDERSTAND RÉSISTANCE ÉLECTRIQUE RESISTENCIA V.1400W-230V.LA50	
3	437086	GUARNIZIONE RESISTENZA VASCA GASKET, TANK RESISTANCE DICHTUNG, TANKWIDERSTAND JOINT RESISTANCE CUVE JUNTA RESISTENCIA CUBETA	
4	80871	MICRO MAGNETICO MAGNETIC DOOR SWITCH TUERKONTAKTSCHALTER CONTACTE MAGNETIQUE CONTACTO MAGNETICO	
5	236052	TERM.CONTATTO BOILER/L.90ø+/-3ø(2611576) THERM.,CONT. BOILER/L.90ø+/-3ø(2611576) THERM.,KONT. BOILER/L.90ø+/-3ø(2611576) THERM.CONTACT CHAUDIERE/L.90ø+/-3ø(2611576) TERM.CONTACTO CALENT./L.90°+/-3°(2611576)	
6	926189	TERMOSTATO BOILER SIC.95ø THERMOSTAT, BOILER, SAF.95ø SICHERHEITSTHERMOSTAT BOILER 95° THERMOSTAT CHAUDIERE SEC. 95ø TERMOSTATO CALENTADOR SEG. 95ø	
7	236035	TERM.CONTATTO /L.60ø+/-3ø(2611573) THERM.,CONT. /L.60ø+/-3ø(2611573) THERM.,KONT. /L.60ø+/-3ø(2611573) THERM.CONTACT /L.60ø+/-3ø(2611573) TERM.CONTACTO /L.60°+/-3°(2611573)	
8	41953	KIT DOSATORE DETERGENTE REG. MANUALE KIT KIT KIT KIT DOSIF. DETERGENTE REG. MANUAL	
9	80952	STAFFA COMPONENTI SOPORTE DOSIFICADORES PG ACABADO	
10	468151	RACCORDO ENTRATA SAPONE CPL NM * SALDATO UNION, EXTRA DET. CPL NM * WELDED TANKEINLAUF CPL NM* RACCORD ENTREE SAVON CPL NM * SOUDE EMPALME ENTRADA JABON CPL NM * SOLDADO	
11	143194	TUBO 4x6 CRISTAL TRASPARENTE PIPE 4x6 CRISTAL, TRANSP. SCHLAUCH 4X6 CRISTAL, DURCHS. TUYAU 4x6 CRISTAL TRANSPARENT TUBO 4x6 CRISTAL TRASPARENTE	
12	143267	TUBETTO 6X10 TUBE 6X10 FLASCHEN 6X10 TUBE 6X10 TUBITO SANTOPRENE 6X10 EMPALMES+VIROLAS	
13	209038	DOSAT.PERIST.DETERG.REG.(NBR-3)BLU ADJUST.PERISTALTIC DETERGENT DISPENSER PERISTALTIK DOSIERUNG REINIGUNGSMITTEL POMPE DOSEUR PERISTALTIQUE DETERGENT REGLABLE DOSIFIC. PERIST.DETERGENTE REG.	ST805RUDD
14	121993	GRUPPO FILTRO DOSATORE FILTER GROUP FILTERANORDNUNG ENSEMBLE DE FILTRE ASAMBLEA DEL FILTRO	
15	224025	PRESSOSTATO 105/125 MAIN PRESSURE SWITCH 105/125 ARBEITSDRUCKWAECHTER 105/125 PRESSOSTAT DE TRAVAIL 105/125 PRESOSTATO 105/125 TRABAJO	
16	224023	PRESSOSTATO - 165/140 MAIN PRESSURE SWITCH 165/140 ARBEITSDRUCKWAECHTER 165/140 PRESSOSTAT DE TRAVAIL 165/140 PRESOSTATO - 165/140	Drain pump

17	143131	TUBO GOMMA PIPE SCHLAUCH FUER DRUCKSCHALTER TUYAU VER CODIGO 143005	
18	107013	CAMPANA PRESSOSTATO PRESSURE SWITCH AIR BELL LUFT-GLOCKE DES DRUCKSCHALTERS CLOCHE PRESSOSTAT CAMPANA PRESOSTATO LA50	
19	456073	OR(50825)CAMPANA PRESS.LA50 O-RING O-RING O-RING OR(50825)CAMPANA PRES.LA50	
20	142058	TROPPO PIENO LA50 OVERFLOW PIPE LA50 UEBERLAUFROHR LA50 BONDE DE SURVERSE LA50 REBOSE LA50	
21	456081	O-RING O-RING O-RING O-RING OR 2.62X28.25(12627)VITON 80SH LA50	
22	121120	FILTRO BASE COMPLETO LA50 FILTER COMPLETE SIEB FILTRE COMPLETE FILTRO BASE COMPLETO LA50	
23	429072	GHIERA CORPO ASPIR./SCARICO LA50 GEWINDERING ZWINGE VIROLE VIROLA CUERPO ASPIR./DESCARGA LA50	
24	456076	OR.D.I.135.9X5.33 ART.53125 OR.D.I.135.9X5.33 ART.53125 TORISCHE DICHTUNG D.I.135.9X5.33 JOINT TORIQUE D.I.135.9X5.33 OR.D.I.135.9X5.33 ART.53125	
25	136028	CORPO ASPIR./SCARICO LA50 ASPIRATION AND DRAIN BODY LA50 ABSAUG-UND ABFLUSSKOERPER LA50 CORPS D'ASPIRATION/VIDANGE LA50 CUERPO ASPIR./DESCARGA LA50	
26	127082	MANICOTTO ASPIRAZIONE MANCHON REFOULEMENT RINÇAGE NACHSPUEL-FOERDERUNGSBOGEN COUDE APIRATION MANGUITO ASPIRACION	
27	CFS1	FASCETTA A VITE TORRO 35-50/9 CLAMP, HOSE-TYPE TORRO 35-50/9 SCHLAUCHSCHELLE TORRO 35-50/9 BANDE DE SERRAGE A VIS TORRO 35-50/9 ABRAZADERA CON TORNILLO TORRO 35-50/9	
28	143252	TUBO SCARICO LA50 DRAIN HOSE ABLAUFLEITUNG TUYAU VIDANGE TUBO DESCARGA LA50	
45	231016	SONDA TEMPERATURA TEMP. PROBE TEMPERATURSONDE SONDE SONDA TEMPERATURA (AMPOLLA ACERO)	
46	H.775489-001	CLIP SONDA TEMPERATURA D5 CLIP FOR TEMP.SENSOR D5 KLIPP FÜR TEMP.FÜHLER D5 CLIP SONDE TEMPERATURE D5 CLIP SONDA TEMPERATURA D5	

vsezip.ru

+7(812)987-08-81

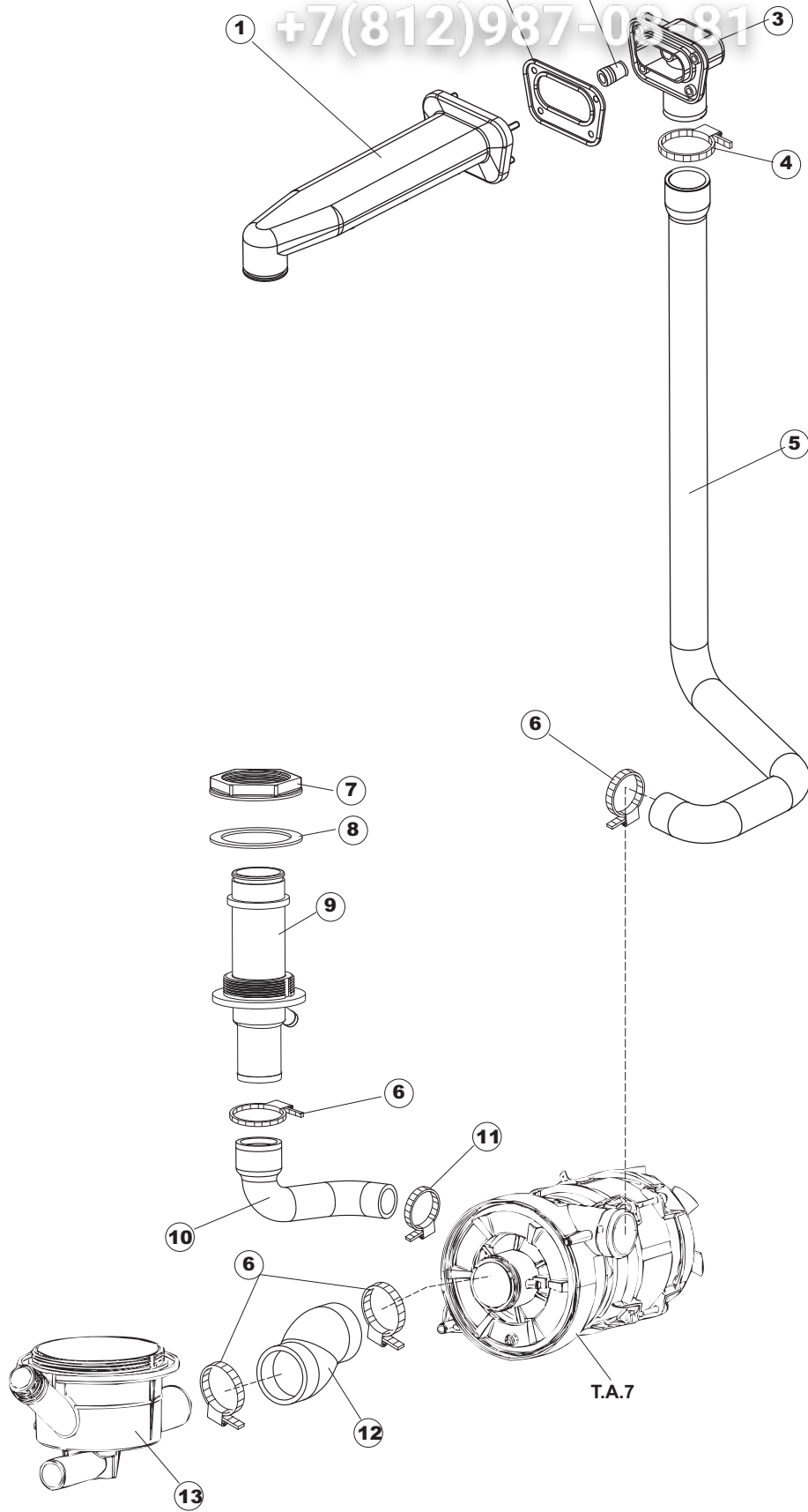

Listino componenti per pagina 4

Зип Общепит

vsezip.ru

+7(812)987-08-81

1	69017	CONDOTTO LAVAGGIO MAINFOLD ZULAULEITUNG DURITE CONDUCTO LAVADO SUP. RIVER	
2	80178	GUARNIZIONE GASKET DICHTUNG JOINT JUNTA	
3	80174	RACCORDO LAV.SUP. EST. GOLD (COL. NEUTRO) UNION, WASH. UPP. OUTS. GOLD (NEUTRAL COL.) VERBINDUNGSST., OB. SPÜL. AUSS. GOLD (NEUTR. FARBE) RACCORD LAV. SUP. EXT. GOLD (COL. NEUTRE) EMPALME LAV. SUP. EXT. GOLD (COL. NEUTRO)	
4	CFS1A	FASCETTA A VITE TORRO W1/W2B 40-60/12 CLAMP, HOSE-TYPE TORRO W1/W2B 40-60/12 SCHELLE, SCHRAUBE TORRO W1/W2B 40-60/12 BANDE DE SERRAGE A VIS TORRO W1/W2B 40-60/12 ABRAZ. CON TORNILLO TORRO W1/W2B 40-60/12	
5	69020	TUBO MANDATA LAVAGGIO SUPERIORE CAPOT FLOW HOSE DRUCKSCHLAUCH TUYAU DE REFOULEMENT TUBO IMPULSION LAVADO SUPERIOR CAPOT	
6	CFS1	FASCETTA A VITE TORRO 35-50/9 CLAMP, HOSE-TYPE TORRO 35-50/9 SCHLAUCHSCHELLE TORRO 35-50/9 BANDE DE SERRAGE A VIS TORRO 35-50/9 ABRAZADERA CON TORNILLO TORRO 35-50/9	
7	429073	GHIERA FISSA CONDOTTO INF. LA50 GEWINDERING MUTTER VIROLE VIROLA FIJA CONDUCTO INF. LA50	
8	437102	GUARNIZIONE CONDOTTO INFER. LA50 GASKET DICHTUNG JOINT JUNTA CONDUCTO INFER. LA50	
9	69016	CONDOTTO LAVAGGIO CONDUCTO CENTRAL INF. LA50 TAPON DOSIF.	
10	127085	MANICOTTO MANDATA INF. LA50 PUMP INTAKE COUPLING LA50 SAUGMUFFE PUMPE LA50 MANCHON ASPIRATION POMPE LA50 MANGUITO IMPULSION INF. LA50	
11	423008	FASCETTA D20X32X9 TIPO TORRO ACC. W1 CLAMP, D20X32X9 TYPE TORRO ACC. W1 SCHLAUCHSCHELLE D20X32X9 TYP TORRO ACC. W1 BANDE DE SERR. D20X32X9 TYPE TORRO ACC. W1 ABRAZADERA D20X32X9 TIPO TORRO ENC. W1	
12	127082	MANICOTTO ASPIRAZIONE MANCHON REFOULEMENT RINÇAGE NACHSPUEL-FOERDERUNGSBOGEN COUDE APIRATION MANGUITO ASPIRACION	
13	136028	CORPO ASPIR./SCARICO LA50 ASPIRATION AND DRAIN BODY LA50 ABSAUG-UND ABFLUSSKOERPER LA50 CORPS D'ASPIRATION/VIDANGE LA50 CUERPO ASPIR./DESCARGA LA50	
15	441009	INSERTO TENUTA D10 COLL. S621- INSERT, SEAL D10 COLL. S621- EINSATZ, DICHT. D10 SAMM. S621- INSERT ETANCHEITE D10 COLL. S621- ELEMENTO ESTANQ. D10 COLECT. S621-	

vsezip.ru

7(812)987-08-81

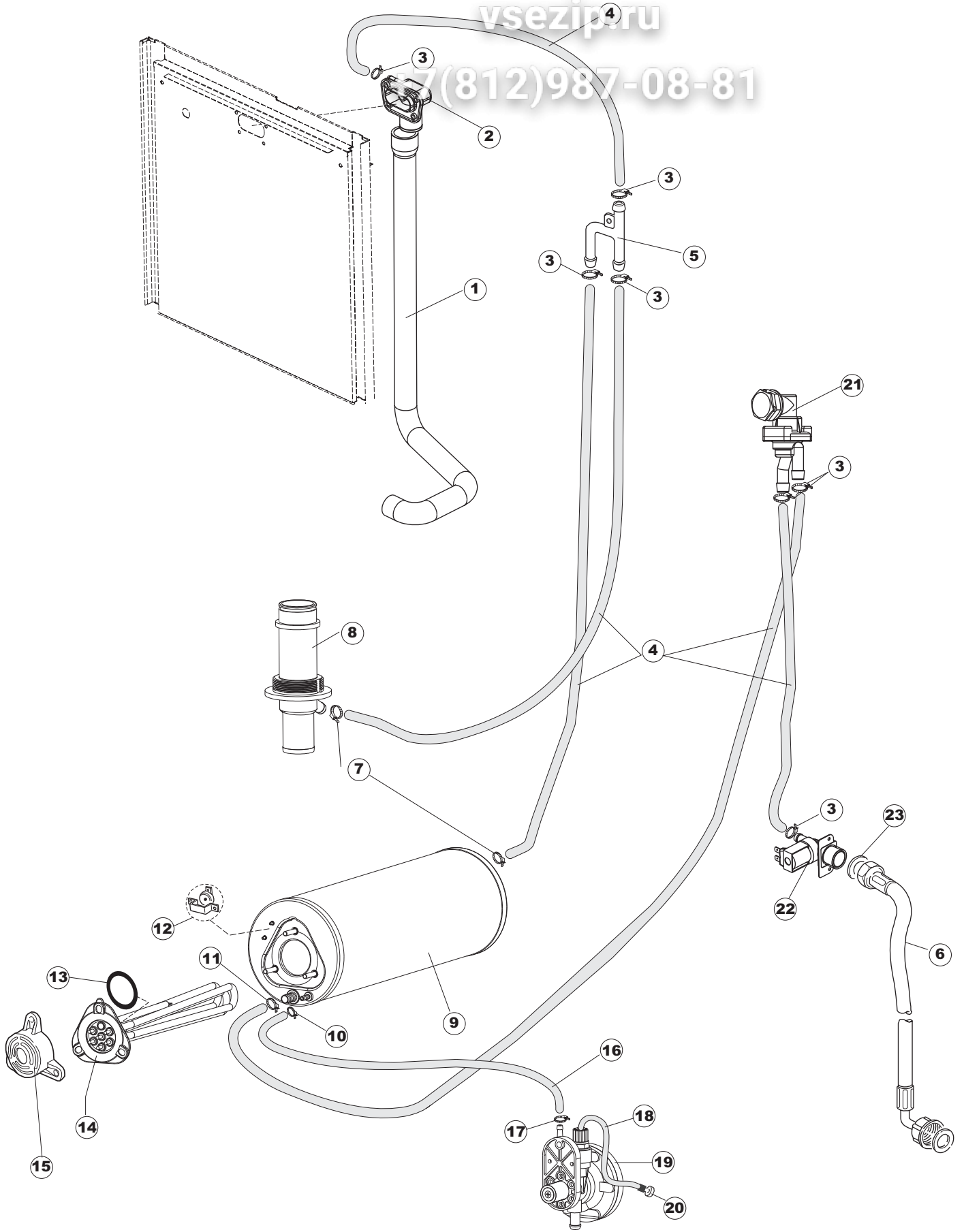

Listino componenti per pagina 5

Зип Общепит

vsezip.ru

87-08-81

1	69020	TUBO MANDATA LAVAGGIO SUPERIORE CAPCT FLOW HOSE DRUCKSCHLAUCH TUYAU DE REFOULEMENT TUBO IMPULSION LAVADO SUPERIOR CAPOT	
2	80174	RACCORDO LAV.SUP.EXT.GOLD (COL.NEUTRO) UNION, WASH.UPP.OUTS.GOLD (NEUTRAL COL.) VERBINDUNGSST., OB.SPÜL. AUSS.GOLD (NEUTR. FARBE) RACCORD LAV.SUP.EXT.GOLD (COL.NEUTRE) EMPALME LAV. SUP. EXT. GOLD (COL. NEUTRO)	
3	927322	FASCETTA NASTRO 14-24 CLAMP, TAPE 14-24 SCHLAUCHSCHELLE 12-22 BANDE DE SERRAGE CONVOYEUR 14-24 ABRAZADERA CINTA 12-22	
4	143010	TUBO PRESS.TP 12X19.5 PIPE, PRESSURE SWITCH TP 12X19.5 ROHR, DRUCKSCHALTER TP 12X19.5 TUYAU PRESS.TP 12X19.5 TUBO PRES. TP 12X19. 5	
5	143173	GIUNZIONE RISC.PLAST - SOS DA 143268 JOINT, RINSE PLAST.35/40/50 VERBIND., NACHSPÜLEN KUNST.35/40/50 JOINT RINC.PLAST.35/40/50 UNION ENJUAGUE PLAST. 35/40/50	
6	929169	TUBO DI CARICO DEL TERMOPLASTICO PIPE, THERMOPLASTIC DELIVERY ZULAUFSCHLAUCH, WASSER THERMOPLAST TUYAU DE CHARG. DU THERMOPLASTIQUE TUBO DE CARGA DEL TERMOPLASTICO	
7	927322	FASCETTA NASTRO 14-24 CLAMP, TAPE 14-24 SCHLAUCHSCHELLE 12-22 BANDE DE SERRAGE CONVOYEUR 14-24 ABRAZADERA CINTA 12-22	
8	69016	CONDOTTO LAVAGGIO CONDUCTO CENTRAL INF.LA50 TAPON DOSIF.	
9	104060	BOILER BOILER BOILER SURCHAUFFEUR LA50 CALENTADOR LA50	
10	423010	FASCETTA D8X12X7,5 TIPO TORRO ACC.W2 CLAMP, D8X12X7,5 TYPE TORRO ACC.W2 SCHELLE, D8X12X7,5 TYP TORRO ACC.W2 BANDE DE SERR. D8X12X7,5 TYPE TORRO ACC.W2 ABRAZADERA D8X12X7,5 TIPO TORRO ENC. W2	
11	927322	FASCETTA NASTRO 14-24 CLAMP, TAPE 14-24 SCHLAUCHSCHELLE 12-22 BANDE DE SERRAGE CONVOYEUR 14-24 ABRAZADERA CINTA 12-22	
12	926189	TERMOSTATO BOILER SIC.95ø THERMOSTAT, BOILER, SAF.95ø SICHERHEITSTHERMOSTAT BOILER 95° THERMOSTAT CHAUDIERE SEC. 95ø TERMOSTATO CALENTADOR SEG. 95ø	
13	456002	OR 48x6,2 O-ring 48x6,2 O-Ring 48x6,2 OR 48x6,2 OR 48x6,2	
14	230117	RESISTENZA BOILER 7600W/400V HEATING ELEMENT 7600W/400V HEIZUNG 7600W/400V RESISTANCE 7600W/400V RESISTENCIA CALENTADOR 7600W/400V(LA50)	
15	69870	PROTEZIONE RESISTENZA BOILER BOILER HEATING ELEMENT PROTECTION HEIZUNGSCHUETZ DES WARMWASSERBEREITERS PROTECTION RESISTANCE BOILER PROTECCION RESISTENCIA CALENTADOR	

16	143005	TUBO PRESS.TP 5x11 (CASER/15/NL C4N) PIPE, PRESSURE SWITCH TP 5x11 (CASER/15/NL C4N) SCHLAUCH TP 5X11 (CASER/15/NL C4N) TUYAU PRESS.TP 5x11 (CASER/15/NL C4N) TUBO PRES. TP 5x11 (CASER/15/NL C4N)	
17	423010	FASCETTA D8X12X7,5 TIPO TORRO ACC.W2 CLAMP, D8X12X7,5 TYPE TORRO ACC.W2 SCHELLE, D8X12X7,5 TYP TORRO ACC.W2 BANDE DE SERR. D8X12X7,5 TYPE TORRO ACC.W2 ABRAZADERA D8X12X7,5 TIPO TORRO ACC.W2	
18	H.775601	TUBO 4x6 CRISTAL BLUE PVC PIPE 4x6 CRISTAL BLUE PVC ROHR 4x6 CRISTAL BLAU PVC TUYAU 4x6 CRISTAL BLEU PVC TUBO 4x6 CRISTAL AZUL PVC	
19	DWD3	DOSAT IDRAUL BRILL.(MAND.D6)DIB0805E4007 DISPENSER, HYDR.XRINSE-AID(MAND.D6)DIB0805E4007 DOSIERER, HYDR. FÜR KLARSP.(MAND.D6)DIB0805E4007 DOS. HYDR. TENSIOACTIF(MAND.D6)DIB0805E4007 DOSIF. HIDRAUL ABRILL. (IMPULS.D6)DIB0805E4011	
20	121993	GRUPPO FILTRO DOSATORE FILTER GROUP FILTERANORDNUNG ENSEMBLE DE FILTRE ASAMBLEA DEL FILTRO	
21	144010	DISPOSIT.A/R.(EB) CON RACCORDO SFIATO CHECK VALVE (EB) W/DRAIN UNION RÜCKSCHLAGVORR.(EB) MIT ENTLÜFTUNG DISPOSIT.A/R.(EB) AVEC RACCORD DE VIDANGE DISPOSIT. A/R. (EB) CON EMPALME ALIVIAD.	
22	240016	VALVOLA DI CARICO 1VIA 3/4 230V PARZ.16L LOADING S.VALVE 1-WAY 3/4 230V PART.16L ZUFLUSSVENTIL 1-WEG 3/4 230V DROSS.16L SOUPAPE DE CHARG. 1VOIE 3/4 230V PARZ.16L VALVULA DE CARGA 1VIA 3/4 230V PARC. 16L	
23	437041	GUARNIZIONE 3/4 GAS CARICO GASKET 3/4 GAS LOAD DICHTUNG 3/4 GASVERSORG. JOINT 3/4 GAZ VID. JUNTA 3/4 GAS CARGA	

vsezip.ru

+7(812)987-08-81

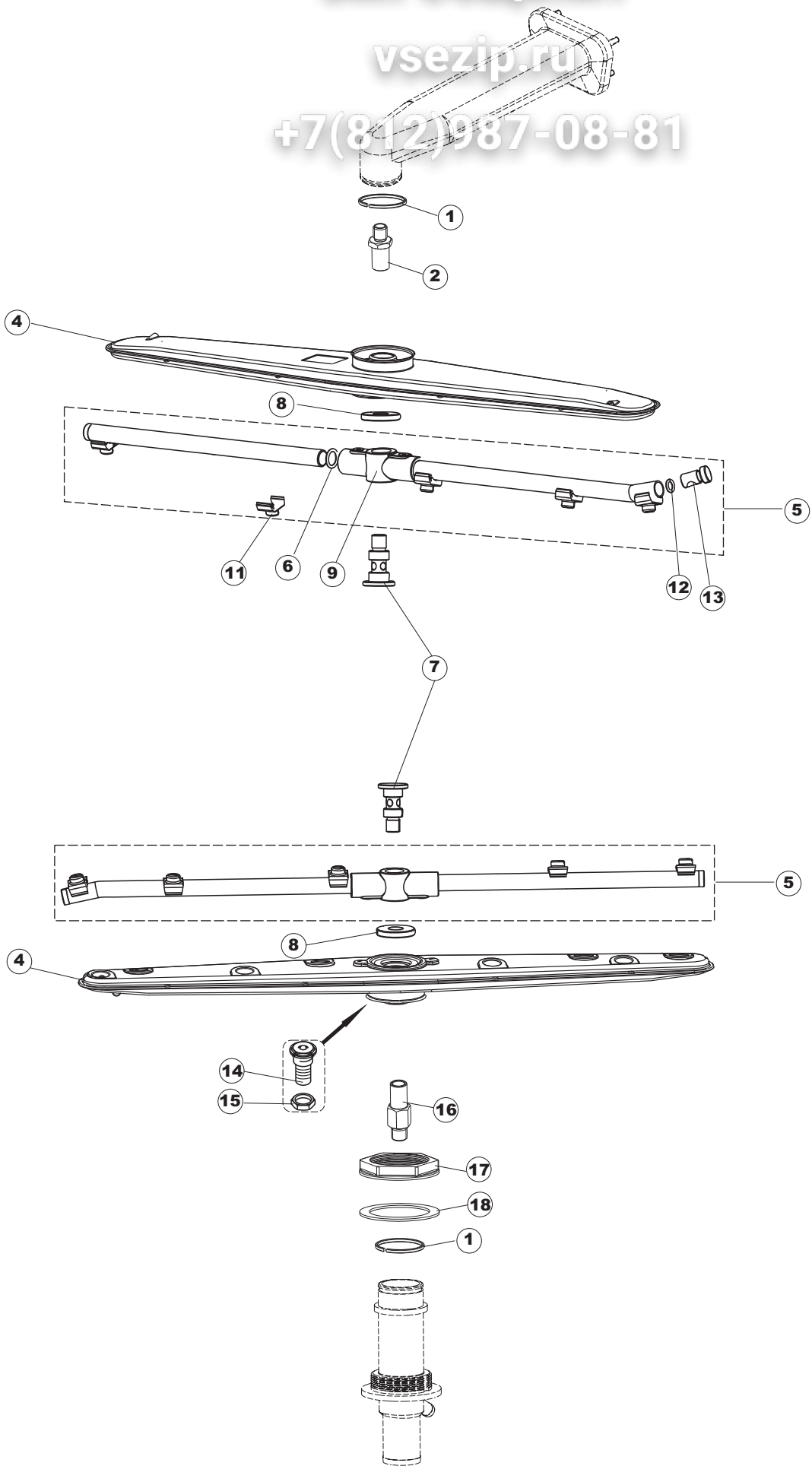

Listino componenti per pagina 6

Зип Общепит

1	80184	ANELLO TENUTA PER SUPP.LAVAGGIO FIXING RING WASHING SUPPORT GLEIT UND DICHTUNGSRING ANNEAU TENUE SUPPORT LAVAGE ANILLO ESTANQ. PARA SOP.LAVADO	
2	79042	PERNO SUPERIORE LAVAGGIO RISCIAQUO C600 UPPER PIN C600 OBERZAPFEN C600 PIVOT SUPERIEUR PERNO SUP. LAVADO/ENJUAGUE C600	
4	80348	PETTINE LAVAGGIO CAPOT WASH ARM SPUELARM BRAS LAV BRAZO LAVADO INOX	
5	69677	BRACCIO RISCIAQUO RINSE ARM NACHSPUELARM BRAS RINC PEINE ENJUAGUE RIVER 80/81	
6	456019	OR 2037 O-ring 2037 O-Ring 2037 OR 2037 OR 2037	
7	80644	PERNO PIVOT BRAS RINCAGE	
8	80679	GHIERA ULTRA RINSE INOX NUT RING BAGUE VIROLA ULTRA RINSE INOX	
9	69632	CORPO PETTINE ARM BODY KOERPER DES NACHSPUELARMES CORPS BRAS CUERPO PEINE ENJUAGUE.	
11	140036	SPRUZZO RISCIAQUO D.2,5 X TUBO D12 RINSE JET DUESE GLICEUR ROCIADOR ENJUAGUE D. 2,5	
12	CGR106	O-RING 106 GOMMA NITR. (6,75 X 1,78 NBR) O-ring 106 NITRILE RUBBER (6,75 X 1,78 NBR) O-RING 106 NITRILGUMMI (6,75 X 1,78 NBR) O-RING 106 CAOUTCHOUC NITRYLE (6,75 X 1,78 NBR) VER CÓDIGO 456030	
13	926132	TAPPO PL.X BRACCIO DI RISC.(DWT312) CAP. PLASTIC FOR WASH. ARM (DWT312) PFROPFEN, KUNST. FÜR NACHSPÜLARM (DWT312) BOUCHON PL.POUR BRAS DE RINC.(DWT312) TAPON PL. X BRAZO DE ENJUAGUE (DWT312)	
14	79044	BOCCOLA X BRACCIO LAVAGGIO INOX C600 WASHING ARM BUSH C600 WASCH-ARME BUCHSE C600 DOUILLE POUR BRAS DE LAVAGE C600 CASQUILLO X BRAZO LAVADO INOX C600	
15	308031	GHIERA BUSSOLA LAVAGGIO X5 RING NUT, WASH.BUSH X5 GEWINDERING, SPÜL.BUCHSE X5 BAGUE DOUILLE LAVAGE X5 VIROLA CASQUILLO LAVADO X5	
16	69282	PROLUNGA PERNO EXTENSION HINGE VERLÄNGERUNGSSTIFT BROCHE D'EXTENSION ALARGADOR PERNO LAV/ENJUAGUE SUP. LA50	
17	429073	GHIERA FISSA CONDOTTO INF.LA50 GEWINDERING MUTTER VIROLE VIROLA FIJA CONDUCTO INF.LA50	

18	437102	GUARNIZIONE CONDOTTO INFER.LA50 GASKET DICHTUNG JOINT JUNTA CONDUCTO INFER.LA50	
----	--------	---------------------------------------------------------------------------------------------	--

+7(812)987-08-81

vsezip.ru

+7(812)987-08-81

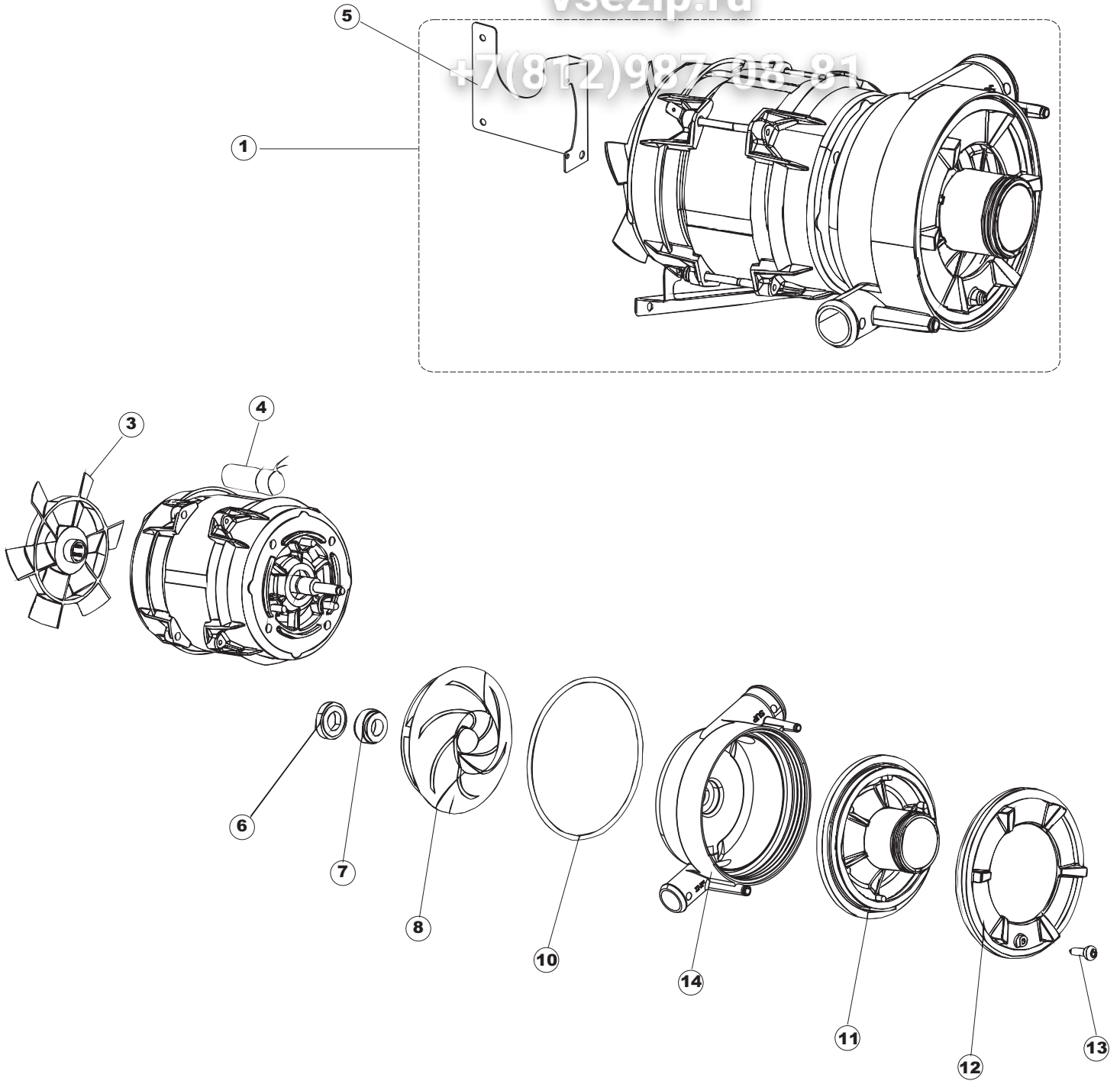

Listino componenti per pagina 7

Зип Общепит

vsezip.ru

7(812)987-08-81

1	69122	ELETTROPOMPA MONOFASE 500W WASHPUMP 50HZ WASCHPUMPE 50HZ LAVER POMPE 50HZ ELECTROBOMBA LA50 500W.230/50-1	
3	335015	VENTOLA POMPA 2400 FAN LUFERRAD VENTILATEUR ROTOR BOMBA 2400	
4	206002	CONDENSATORE DA 10 mF CONDENSER - 10 mF KONDENSATOR - 10 mF CONDENSATEUR DE 10 mF CONDENSADOR DE 10 mF	
5	69400	STAFFA POMPA LA50 PUMP SUPPORT PUMPENTRÄGER SUPPORT DE LA POMPE SOPORTE BOMBA LA50 PG ACABADO	
6	141008	TENUTA MECCANICA PER POMPA DI LAVAGGIO PER LAVABICI WASH PUMP SHAFT SEAL FOR GLASSWASHER MECHANISCHE DICHTUNG FUER WASCHPUMPE DER GLAESE ETANCHEITE' DE LA POMPE DE LAVAGE POUR LAVE-VERRES SELLO MEC.FISJO BOMBA	
7	141009	TENUTA MECCANICA PER POMPA DI LAVAGGIO PER LAVABICI WASH PUMP SHAFT SEAL FOR GLASSWASHER MECHANISCHE DICHTUNG FUER WASCHPUMPE DER GLAESE ETANCHEITE' DE LA POMPE DE LAVAGE POUR LAVE-VERRES SELLO MEC.GIRAT. BOMBA(0142R)	
8	124057	GIRANTE+INSERTO POMPA(2398R) IMPELLER PUMPENFLUEGEL TURBINE ROTOR+ELEMENTO BOMBA	
10	456078	OR.POMPA(2402R)3.53X170.5 OR.PUMP (2402R)3.53X170.5 TORISCHE DICHTUNG JOINT TORIQUE OR.BOMBA 3.53X170.5	
11	480148	TAPPO CHIOCCHIOLA POMPA(2399R) PUMP CAP DECKEL PUMPE BOUCHON POMPE TAPON ESPIRAL BOMBA	
12	429074	GHIERA FILETTATA POMPA(2434R) NUT RING DOUILLE VIROLA ROSCADA BOMBA	
13	486242	VITE 3.5X13 TBC UNI6954(0062R) SCREW 3.5X13 SCHRAUBE 3.5X13 VIS 3.5X13 TORNILLO 3.5X13 TBC UNI6954	
14	116032	CORPO POMPA LA50(2433) PUMP HOUSING PUMPENGEHAEUSE CORPS POMPE CUERPO BOMBA LA50	

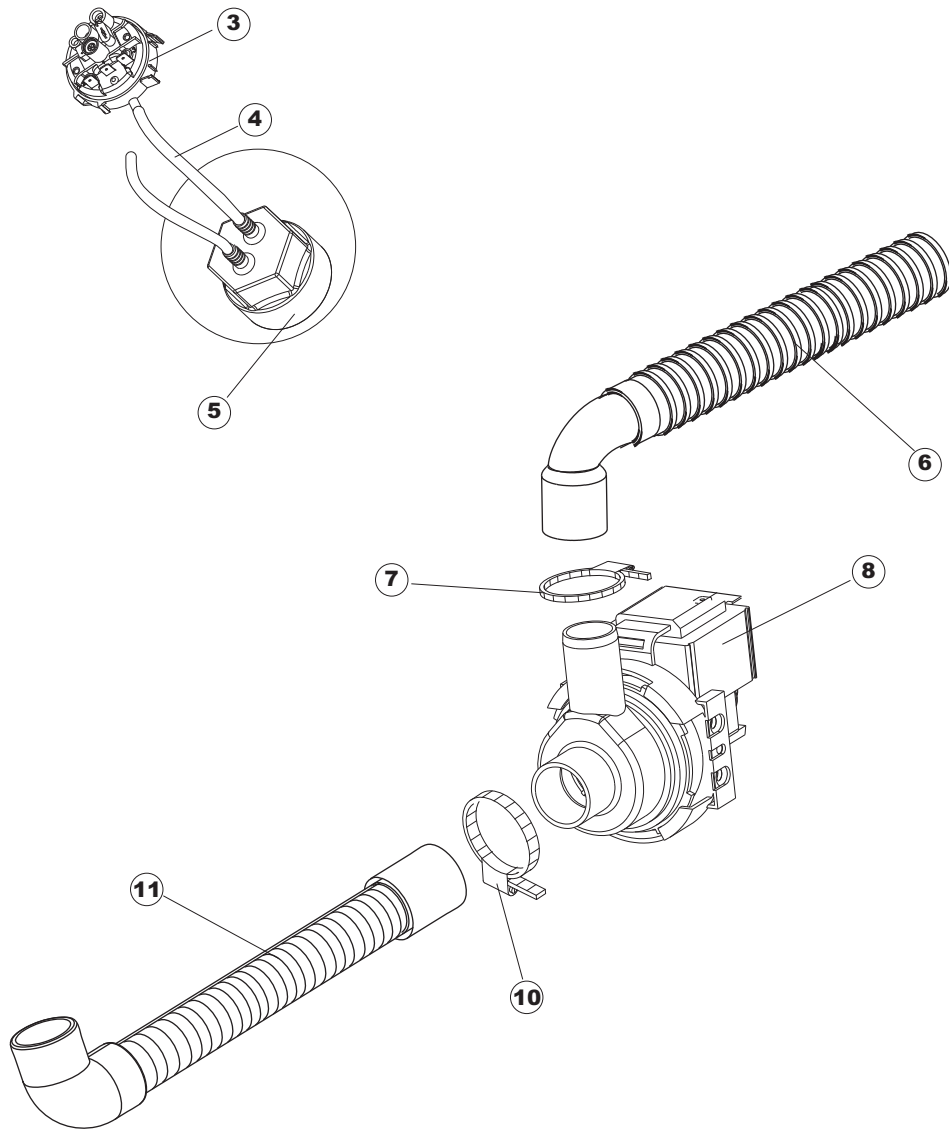

Drain pump

1

Listino componenti per pagina 8

Зип Общепит

vsezip.ru

(812)987-08-81

1	70710	KIT POMPA SCARICO (50HZ) CAPOT DRAIN PUMP KIT KIT FUR ABLAUFpumpe KIT POMPE DE VIDANGE (50HZ) KIT BOMBA DESCARGA (50HZ)	
3	224023	PRESSOSTATO - 165/140 MAIN PRESSURE SWITCH 165/140 ARBEITSDRUCKWAECHTER 165/140 PRESSOSTAT DE TRAVAIL 165/140 PRESOSTATO - 165/140	
4	143131	TUBO GOMMA PIPE SCHLAUCH FUER DRUCKSCHALTER TUYAU VER CODIGO 143005	
5	107014	CAMPANA PRESSOSTATO LA50 PRESSURE SWITCH AIR BELL LA50 LUFT-GLOCKE DES DRUCKWAECHTERS LA50 CLOCHE AIR PRESSOSTAT LA50 CAMPANA PRESOSTATO LA50	
6	DZS151	TUBO SCARICO PL CM150 D25 (2 MANIC.) PIPE, DRAIN PL CM150 D25 (2 HANDL.) ABLASSROHR, KUNST. CM150 D25 (2 ST.) TUYAU VIDANGE PL CM150 D25 (2 POIGNEES) TUBO DESCARGA PLAST. CM150 D25 (2 MANG.)	
7	CFS18	FASCETTA A VITE TORRO 20-32/9 CLAMP, HOSE-TYPE TORRO 20-32/9 SCHLAUCHSCHELLE 20-32/9 BANDE DE SERRAGE A VIS TORRO 20-32/9 ABRAZADERA CON TORNILLO TORRO 20-32/9	
8	80117	POMPA SCARICO RIVER DRAIN PUMP RIVER ABLASSpumpe RIVER POMPE VIDANGE RIVER BOMBA DESCARGA RIVER	
10	CFS1	FASCETTA A VITE TORRO 35-50/9 CLAMP, HOSE-TYPE TORRO 35-50/9 SCHLAUCHSCHELLE TORRO 35-50/9 BANDE DE SERRAGE A VIS TORRO 35-50/9 ABRAZADERA CON TORNILLO TORRO 35-50/9	
11	70097	TUBO DI SCARICO DRAIN HOSE DRAINAGEROHR TUYAU DE VIDANGE TUBO DE DESAGÜE	