

Зип Общепит

vsezip.ru

+7(812)987-08-81

Sottoriva

INSTRUCTION MANUAL

Dough Sheeter

Mod. SPT0/1-E - SPT3/1-E

Version: ENGLISH Arch.: 86

Code: 3529.0031.01

Revision: A dated 06/09/2011

Costruzioni Meccaniche SOTTORIVA S.p.A.

Via Vittorio Veneto, 63 - 36035 MARANO VICENTINO (VI) ITALIA

Phone (+39) 0445.595.111 - Fax (+39) 0445.595.155

Web site: www.sottoriva.com - E-mail: sottoriva@sottoriva.com

Зип Общепит

vsezip.ru

+7(812)987-08-81

MANUAL DOUGH SHEETER

mod. SPT0/1-E
and
mod. SPT3/1-E



Photo 1

This manual contains the guarantee coupon

Зип Общепит

vsezip.ru

+7(812)987-08-81



**USE AND MAINTENANCE MANUAL
MANUAL DOUGH SHEETER
Mod. SPT0/1-E - SPT3/1-E**

Code
3529.0031.01
Revision A
date
06/09/2011

1- GENERAL	4
1.1. GUARANTEE	5
1.2 GENERAL WARNINGS AND APPLICATION	6
1.3 RATING PLATE DATA	7
1.4 TRANSPORT INSTRUCTIONS	8
1.5 ASSEMBLY	9
1.6 INSTRUCTIONS FOR INDOOR HANDLING	11
1.7 DECOMMISSIONING	11
2- TECHNICAL SPECIFICATIONS	12
2.1 TECHNICAL DESCRIPTION	13
2.2 TECHNICAL SPECIFICATIONS	15
3- STARTING UP	16
3.1 INSTALLATION	17
3.2 CONNECTION TO THE MAINS	18
4 - INSTRUCTIONS FOR USE	19
4.1 GENERAL INFORMATION	20
4.2 USE OF THE MACHINE	21
4.3 MACHINE CONTROLS	22
5- MAINTENANCE AND CLEANING	23
5.1 MAINTENANCE	24
5.2 CLEANING	24
6- OPERATING FAULTS	26
6.1 TROUBLE SHOOTING	27
7- SAFETY WARNINGS	28
7.1 SAFETY DEVICES	29
7.2 SAFETY AND IDENTIFICATION PLATES	30
7.3 PROHIBITIONS AND OBLIGATIONS FOR PREVENTION OF ACCIDENTS	31
8 - SPARE PARTS	32
8.1 INSTRUCTIONS FOR ORDERING	33
8.2 PLATE N° 1 - STRUCTURE AND COMPONENTS	34
8.3 PLATE N° 2 - PULLEY AND MOTOR UNIT SPT0/1-E – SPT3/1-E	35
8.5 PLATE N° 4 - HANDLE UNIT	37
8.5 PLATE N° 4 - HANDLE UNIT	38
8.6 PLATE N° 5 - CONVEYOR BELT UNIT	39
8.7 TAV. N°7 - SCRAPERS	40
8.8 TAV. N° 7 – BASEMENT GROUP	41
8.9 ADVISABLE SPARE PARTS	45
9- ACCESSORIES ON REQUEST	47
9.1 2-SPEED MACHINE FOR CUTTING DEVICE APPLICATION	48
9.2 ROLLERS HOLDER FOR DOUGH CUTTING	48
9.3 ROLLERS WITH VARIOUS SIZES AND SHAPES	48
10- ELECTRICAL EQUIPMENT	49
10.1 DESCRIPTION	50
10.2 DOCUMENTATION	51



**USE AND MAINTENANCE MANUAL
MANUAL DOUGH SHEETER
Mod. SPT0/1-E - SPT3/1-E**

Code
3529.0031.01
Revision A
date 06/09/2011

+7(812)987-08-81

1- GENERAL



**USE AND MAINTENANCE MANUAL
MANUAL DOUGH SHEETER
Mod. SPT0/1-E - SPT3/1-E**

Code
3529.0031.01
Revision A
date
06/09/2011

1.1. GUARANTEE

The manufacturer guarantees the good working and the quality of this sheeter for a period of 6 months from the shipping date, in the case ONLY of mailing the underneath filled and signed coupon within 15 days from receipt of the machine.

The guarantee will be valid only with the correct use and maintenance of the machine as per enclosed instructions.

The guarantee won't be any more valid in in the following cases:

- non-authorized modifications or work on the machine;
- use of non-original spare parts or parts not specific for the model;
- failure to follow the instructions, even partially.
- normal wear of the concerned parts.

The guarantee is limited to the substitution of the defected part only. All the other claims such as indemnities for interruption of the production or similar are not considered in the guarantee.

If necessary, the supplier can ask the machine to be returned for repair during the guarantee period.

to be rendered to the supplier

This coupon has to be mailed back to the supplier before starting working with the machine

1.2 GENERAL WARNINGS AND APPLICATION

The aim of this manual is:

- To facilitate understanding and operation of the machine and enable the system to be used to its full technical potential.
- To provide instructions for the most effective and rational maintenance and help the operator to understand any faults and how to remedy them.
- To warn against risks inherent in use of the machine due to failure to observe the safety regulations.
- To indicate working limits for maintaining hygiene and environmental conditions and to ensure health at work.

These pages must be read carefully before starting the machine.

This manual forms an integral part of the product; it must be kept near the machine for prompt easy consultation and must also be kept for future reference until the machine is scrapped.

The manufacturer does not guarantee the technical-legal suitability of the installation premises and machine supporting services but provides all instructions for correct installation in the relevant section of this manual.

For the above, the user is advised to contact an expert professional technician, also for compliance with any local laws or regulations.

- The machine is designed for the food industry.
It is a machine designed for sheeting of dough obtained with different types of ingredients like flour, water, sugar, fat, butter, salt, yeast, etc. and of medium consistency for cake-making in general.
- The machine must be used only for the purpose for which it has been designed. All other uses are considered inappropriate and therefore unreasonable.

The manufacturer cannot be held liable for incorrect use, inappropriate and/or unreasonable acts.

The manufacturer cannot be held liable for any damage caused by inappropriate, incorrect or unreasonable use, for example:

- inappropriate use by non-trained personnel;
- non-authorized modifications or work on the machine;
- use of non-original spare parts or parts not specific for the model;
- failure to follow the instructions, even partially.

1.3 RATING PLATE DATA

The picture 0A shows exactly the registration plate applied on the machine. On picture 2 an arrow indicates the position where this plate is fixed on the basement of the machine. The plate is realised in serigraphed aluminium and all the registration datas are engraved, to last as long as possible.

picture 0A

C. M. SOTTORIVA S.p.A. Via Vittorio Veneto, 63 36035 MARANO VIC.NO (VICENZA) - ITALY	Tel. (+39) 0445.595.111 Fax (+39) 0445.595.155 Email: sottoriva@sottoriva.com Web site: www.sottoriva.com
Mod.	SPT0/1-E (o SPT3/1-E)
N°	□□□□□
V □□□ Hz □□	A □□ 3 AC + (N) + T
kW □□	Massa kg □□□□
201_	



Photo 2

1.4 TRANSPORT INSTRUCTIONS

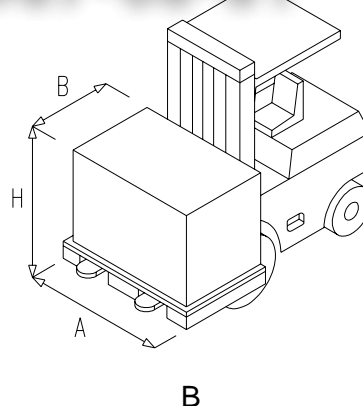
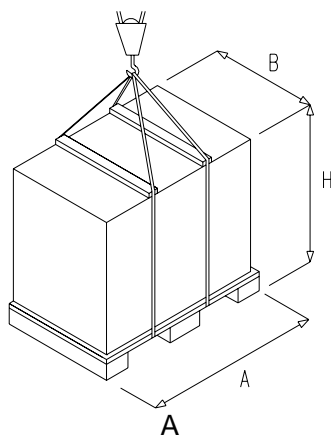

PACKAGING DATA

- The machine is supplied on a pallet, in a strapped triple-layer corrugated cardboard box.

MACHINE MOD.	TYPE OF PACKAGING	WEIGHT KG	A mm	B mm	H mm
SPT0/1-E	Pallet and cardboard box		1120	1170	1740
SPT0/1-L-E	Pallet and cardboard box		1120	1170	1740
SPT3-1-L	Pallet and cardboard box		1120	1170	1740

INSTRUCTIONS FOR TRANSPORT AND UNLOADING

- Loading and unloading from the vehicle can be performed:
 - by means of crane, see figure "A"
 - by means of forklift truck, see figure "B".
- The machine must be transported adopting all precautions to prevent damage to the machine.
- In particular the machine must not be placed on top of other materials and vice versa either during transport or storage.
- During transport the machine must be positioned so that it cannot be knocked by other materials loaded on the same vehicle.
- Before unloading from the vehicle, check that the packaging is intact and that there is no risk of tipping over.
- During unloading, place the machine carefully on the ground to prevent it being knocked.



CAUTION

When handling, pay attention to all the indications on the packaging. The capacity of the belts must be adequate for the weight of the packages. Do not use metal belts.

1.5 ASSEMBLY

+7(812)987-08-81

The machine is delivered on a pallet and wrapped with plastic. In order to assure a safe transportation, the working tables are disassembled and the basement is fixed with 4 screws.

It is necessary to take off the plastic carefully in order to avoid the tables or other compounds to fall down.

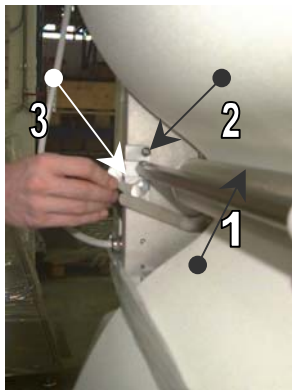

On the picture is indicated with number 1 a shaft located behind the tables which has to be used as table support. Unscrew the screw nr.2 to release the shaft and turn round the plate nr 3. This operation has to be done on both sides of the machine.

Be careful not to lose the 2 white plastic rings on the shaft 1

Photo 3



the shaft will be hanged on the table from side to side.

The 2 white rings are mounted on each end of the shaft

Photo 4



Now the table will be hoisted in order to replace the shaft on its seat, then it is necessary to block it with the plate nr 3 and fix the plate with the screw as indicated on number 2 on the side picture

Photo 5

Inside the packing is located the 2 table supports. The assembly of these supports is very easy.
Once the table is assembled, it is necessary to keep it up to mount the supports.
The supporting leg has to be hanged inside the porthole as indicated in the side picture



Revolve lightly the leg and lift it up till the screws on the table, unscrew the screws and fix them with the leg ends as indicated on the side picture.

Photo 6

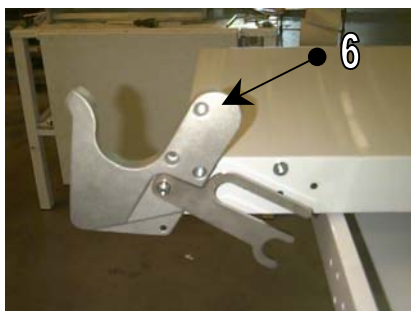

The table ends are fitted with 2 belt ties. Le estremità del piano sono dotate di una coppia di tiranti tappeto che servono anche da appoggio per i piani. Come indicato nella foto a lato con il numero 6.

Photo 7

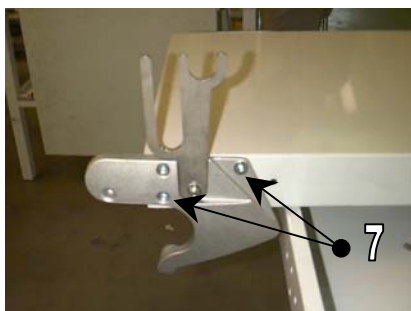

Unscrew the 2 screws indicated on point 7, revolve all the group (the 2 legs and the free wheel) until the position indicated on side picture, then screw back again the screw 7 as previous position tightening the belt.

Now the table is completely assembled, proceed on the same way to assemble to opposite one. To unpack completely the machine, it is necessary to open the 2 side doors; inside the basement is fixed to the pallets by 4 screws. Remove the screws to take off the machine

Photo 8

1.6 INSTRUCTIONS FOR INDOOR HANDLING

The dough sheeter mod.SPT0/1-E – SPT3/1-E is provided with three wheels, two rear wheels(*) and one front wheel, and two stabiliser feet located at the side of the front wheel. The front wheel is operated by a mechanical pedal located at the front of the machine just above floor level. The stabiliser feet are designed to ensure correct machine stability with respect to the floor. The machine must be positioned in its place of work using the wheels. As soon as you have found the ideal work position, press the pedal: the machine will be lowered slightly and the two feet will rest on the floor. To move the machine again, raise it four centimetres by means of the handle and release the weight. The front wheel is now ready for operation.

If you need to clean the floor or other, the two side worktops can be raised. This operation must be performed raising one worktop at a time. Once maximum lifting position has been reached, a mechanical stop will cut in consisting of a pin in the worktop engaging in a slot in the protection grid.

Once the machine is positioned on the other place, stabilise it through the pedal located on the bottom of the basement.



CAUTION

Indoor handling must be performed by adopting all the precautions necessary to prevent damage to the machine components.

(*) The front or rear position is defined with respect to an operator standing in front of the calibration thickness adjustment handle.

1.7 DECOMMISSIONING

1.7.1 SETTING ASIDE

- If the machine has to be stored, it must be protected against dust and stored in a covered place.
- If the machine is not going to be used for a long time, it must be protected against dust and atmospheric agents by means of appropriate covering.
- No special precautions are required for the motor and electrical system; simply follow the above instructions.

1.7.2 SCRAPPING

- To scrap the machine, proceed as follows:
 1. Eliminate the electricity supply cable.
 2. Remove all moving parts that could be a hazard.
 3. Dispose of the majority of parts as scrap metal and take to authorised scrapyards.
 4. The other parts, plastic for example, must be disposed of according to current regulations, via specialist firms if necessary.



**USE AND MAINTENANCE MANUAL
MANUAL DOUGH SHEETER
Mod. SPT0/1-E - SPT3/1-E**

Code
3529.0031.01
Revision A
date 06/09/2011

vsezip.ru
+7(812)987-08-81

2- TECHNICAL SPECIFICATIONS

2.1 TECHNICAL DESCRIPTION

+7(812)987-08-81

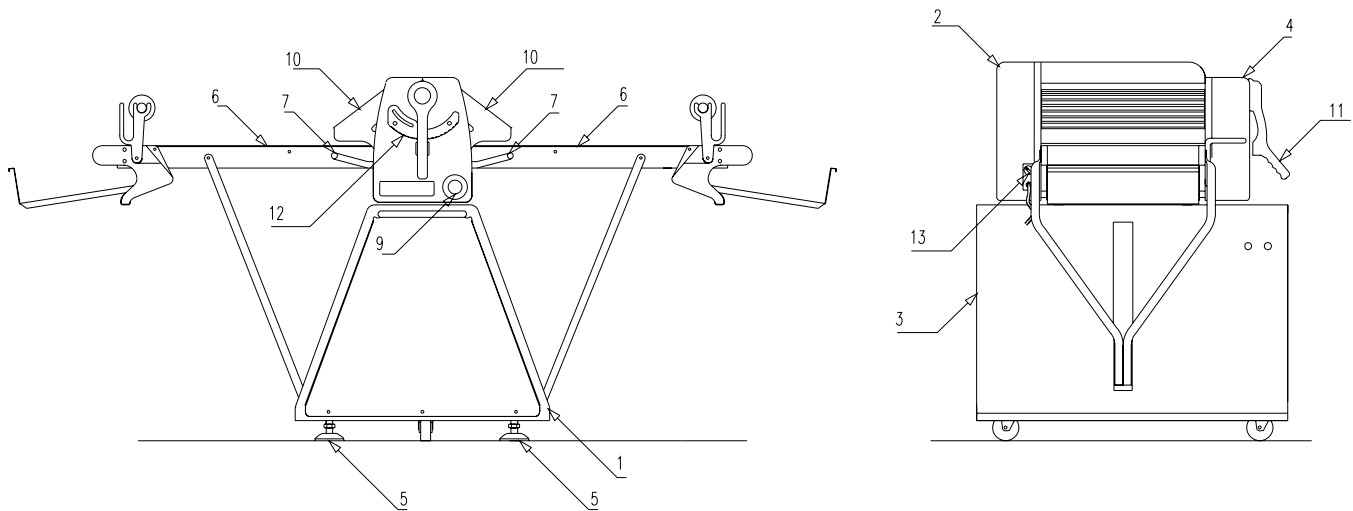

APPLICATION

- The machine is designed for the food industry.
It is a machine designed for sheeting of dough obtained with different types of ingredients like flour, water, sugar, fat, butter, salt, yeast, etc. and of medium consistency for cake-making in general.
- The machine must be used only for the purpose for which it has been designed. All other uses are considered inappropriate and therefore unreasonable.

COMPOSITION OF THE MACHINE

Model SPT0/1-E – SPT3/1-E

- The dough sheeter consists mainly of a supporting structure (1) and three plastic covering panels (2) - (4).
- The supporting structure (1) consists of a shaped welded metal sheet made of painted steel with two sides (in aluminium) fitted above it and screwed together by means of metal spacers.
- Cover (2) houses the belt drive unit. Cover (3) houses the electric motor and cover (4) the drive unit, called clutch unit, for reversing the movement of the machine.
- The base is provided with levelling system (5) to ensure machine stability.

OPERATION

Model SPT0/1-E – SPT3/1-E

+7(812)987-08-81

- The conveyor belts (6) are operated by the control lever (7), with movement according to the position of the lever. It has two side operating positions and one central position (idle). By turning the lever to the left, the conveyor belt (6) will move from right to left and vice versa; if the lever is set to the central intermediate position (idle) the conveyor belts will be at a standstill.
- If devices other than the control lever (7) are activated during operation, for example one of the two safety grilles (10) is raised, the machine will immediately stop. Press the start button (9) to re-start the machine.
- Via the handle (11) the product thickness can be varied from zero (0) millimetres to thirty-five (35) millimetres. The rolling thickness expressed in millimetres can be read on the self-adhesive label coinciding with one of the handle references. Rolling must be performed gradually, starting from the thickest size (35 mm) and gradually reaching the thickness required.

MACHINE MOVEMENT

- The single-speed motor operates the calibration cylinders via pulley, belt and driven pulley. In their turn, the calibrating cylinders operate the clutch centre drive. The electric motor rotation can be reversed by means of the control lever (7) in conjunction with internal switches. This control lever pivots the coupling gears which, according to the motor rotation direction, engage the drive cylinder of one of the conveyor belts.

PROTECTIONS

- The central area consisting of the two calibrating cylinders, considered the most dangerous area for the operator, is completely covered and protected by two side protection grilles (10). They are made entirely of stainless steel. If one of the two grilles is raised, even by a few millimetres, a microswitch will cut in, immediately stopping the machine.
- The conveyor surfaces, on which the conveyor belts rotate, are designed so that the operator cannot insert his fingers between the surface and the belt.

ELECTRICAL SYSTEM

All the electrical components subject to rated voltage and the electric motors are enclosed in a casing with IP 54 protection rating. The control elements, push-buttons and selectors operate at low voltage (24V) and are enclosed in casing with IP 54 protection rating.

The machine is designed for earth connection to protect against indirect contact risks (Chap. 10). The electrical power and control circuit is provided with its own protection devices against short circuits and overloads.

On the front of the machine, opposite the operator's normal working position, is the stop/emergency button (see chap. 4.2). This button disables the start buttons, thus preventing the machine from being started. Reset, which is obtained by pulling the button cap, does not automatically restart the machine.

2.2 TECHNICAL SPECIFICATIONS

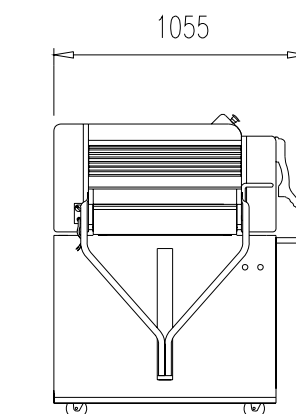
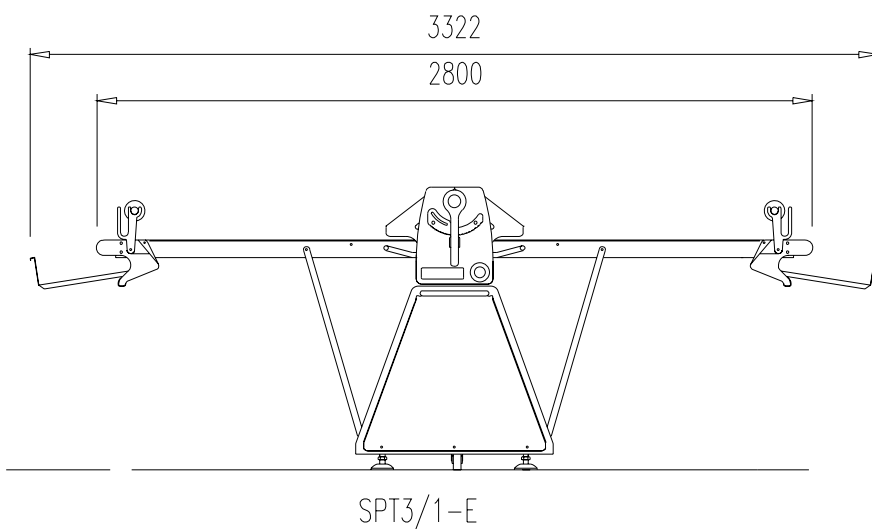
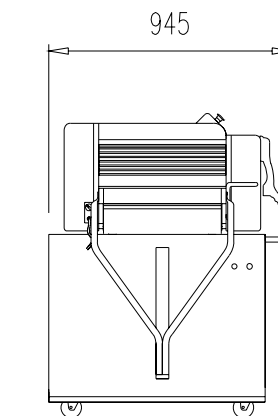
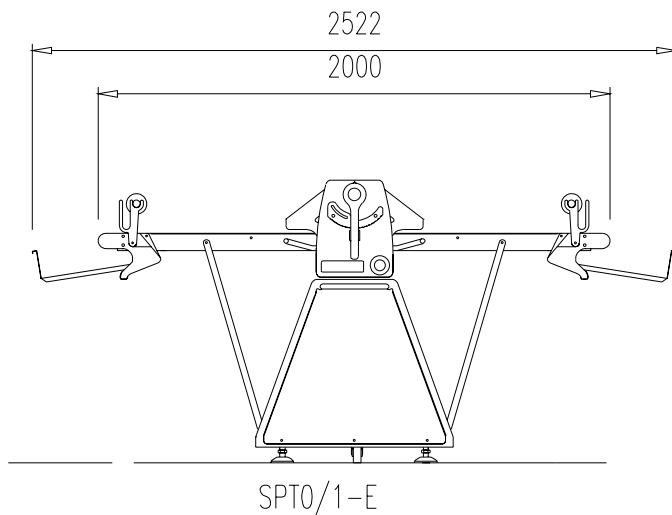

MODEL	Cylinder diam.	Cylinder opening	Outlet belt speed	Belt width	Belt length	Motor power kW	Weight kg
SPT0/1-E	84 mm	0.2-35 mm	50 cm/sec	500	750	0.55	140
SPT0/1-L-E	84 mm	0.2-35 mm	50 cm/sec	500	1000	0.55	150
SPT3/1-E	84 mm	0.2-35 mm	50 cm/sec	600	1000	0.55	160

NOISE: below 70 dB.



**USE AND MAINTENANCE MANUAL
MANUAL DOUGH SHEETER
Mod. SPT0/1-E - SPT3/1-E**

Code
3529.0031.01
Revision A
date 06/09/2011

vsezip.ru
+7(812)987-08-81

3- STARTING UP

3.1 INSTALLATION

+7(812)987-08-81

- Choose a suitable place for installing the machine, observing the minimum distances from the walls as shown in the figure at the side. These spaces are necessary for cleaning and routine maintenance operations and also ensure safe operating conditions without the danger of dragging in and/or crushing.
- The room must be provided with adequate lighting and ventilation.

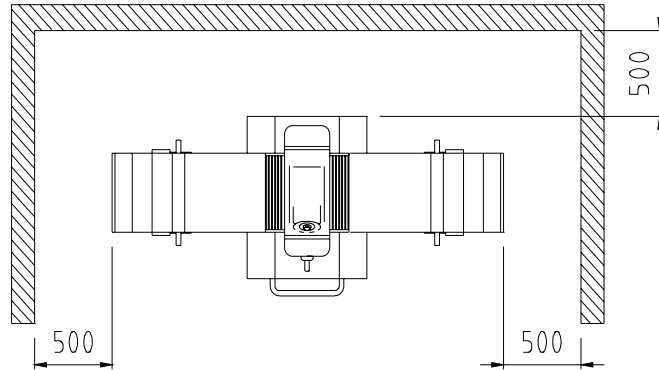

- Check that the connections have been made as specified in this manual (electricity).
- After unpacking the machine, ensure that it is in perfect condition, checking that there are no visibly damaged parts. If in doubt, contact professionally qualified personnel (your dealer) and do not use the machine.
- The packaging elements (plastic, nails, screws, wood etc.) must not be left within the reach of children as they are potential hazards; they must be appropriately disposed of, especially if they are polluting.



CAUTION

For ambient lighting you are advised to follow the specifications of the laws in force.

- Position the machine and ensure that it is stable:
 - Adjust the height of the foot by tightening or loosening it until the machine is stable.

Once the machine has been levelled, it will remain stable and does not require any anchoring to the ground.

N.B.: All the machine feet are adjustable.

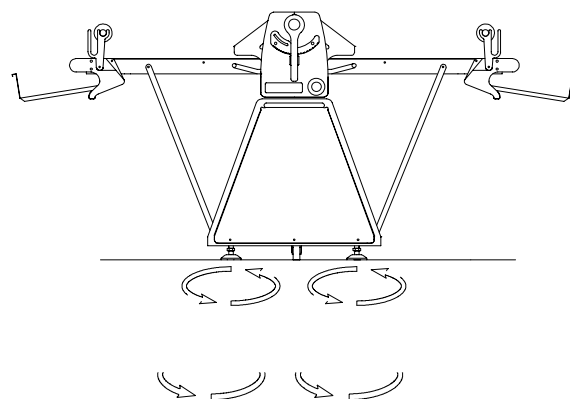

3.2 CONNECTION TO THE MAINS

- The machine is provided with one single electrical connection with connection cable at the rear.
- Check that the rating plate voltage corresponds to the mains voltage.
- The machine must be connected to a manual control voltage disconnection device fitted in an easily accessible position so that the machine electrical equipment can be separated from the mains when necessary (e.g. during maintenance or cleaning).
- For sizing of the cable and disconnection device, see wiring diagram data.
- If not supplied, fit a retention plug to the machine connection cable suitable for the disconnecting device installed and connect to the socket.
- Following the operating instructions (Chap. 4), with the machine empty, start and run a few right and left rolling tests, adjusting the rolling thickness.
- To connect the plug to the supply cable (when not provided) refer to figure -a1-; this operation must be performed in compliance with the "CAUTION" note at the foot of the page.

Fig. -a1-

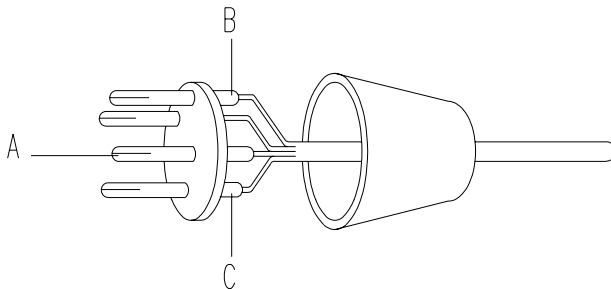

NOTE: REGULATIONS FOR SAFETY OF ELECTRICAL SYSTEMS

In Italy electrical equipment must meet the requirements not only of the CEI technical specifications but also the provisions of the law of 5.3.1990, no. 46, and related Implementation Regulation, DPR 6.12.1991, no. 47.

In particular, the system must be installed by a technically and professionally qualified electrician listed in the appropriate register. The installer is obliged to provide the customer with a declaration of conformity.

Old systems should be checked in order to adapt them to the latest safety regulations and state-of-the-art.



CAUTION

Operations on the electrical part of the machine, even if minor, must be performed by professionally qualified personnel.



**USE AND MAINTENANCE MANUAL
MANUAL DOUGH SHEETER
Mod. SPT0/1-E - SPT3/1-E**

Code
3529.0031.01
Revision A
date
06/09/2011

+7(812)987-08-81

4 - INSTRUCTIONS FOR USE

4.1 GENERAL INFORMATION

DO NOT use the machine with frozen products.
 DO NOT perform maintenance operations with the machine powered.
 DO NOT open the electrical board unless specifically authorised to do so.
 CONNECT the machine electrically in compliance with current regulations.
 CONNECT the machine to earth.

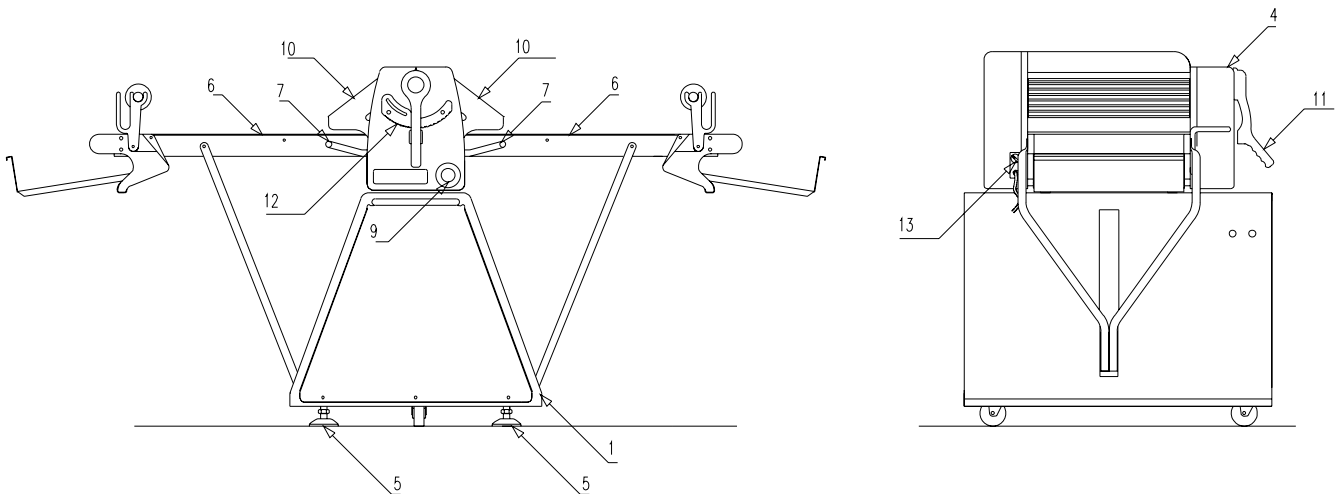

- The conveyor belts (6) convey the dough to be rolled through the calibration cylinders from right to left and vice versa. This right-left direction variation is determined by the control lever (7) as follows: when the lever is turned to the left, movement is from right to left whereas if it is turned to the right, movement will be from left to right.
- The job of the calibration cylinders is to give the dough a uniform thickness, starting from the thickest (35 mm) and gradually reaching the required finer thickness. To repeat the final thickness obtained on subsequent batches of dough, a mechanical stop (12) is provided which operates resting against the handle. As soon as you have finished the first rolling operation, loosen the stop (12), slide it, rest it against the handle and retighten it. Repeat the operation with a new batch of dough until you obtain the final thickness obtained previously.
- Variation of the rolling thickness is obtained by moving the handle (11); the value to be obtained, expressed in millimetres, can be read on the label immediately below the handle.

4.2 USE OF THE MACHINE

- Rest the dough to be rolled in the middle of the right-hand conveyor surface. Using the rolling pin provided, roll the dough in right-left and forward-back movements to reduce the thickness until you obtain a thickness of approximately 40/50 mm.
- Set the adjustment handle (11) to maximum opening.
- Ensure that the movement control lever (7) is in the central “idle” position. Switch the master switch (13) from position “0” to position “1”. Ensure that the emergency push-button (9) is disengaged.
- Turn the control lever (7) to the left; this will move the conveyor belt from right to left. As soon as all the dough has moved beyond the cylinders, reset the control lever (7) to the central idle position (*), thus stopping the machine. Reduce the rolling thickness by approximately 4/8 mm. Turn the control lever (7) to the right, thus moving the conveyor belt from left to right. This operation must be repeated until you obtain the required final thickness.
- As soon as you finish the penultimate rolling operation, the machine must be set to wrap the sheet obtained around the rolling pin. Set the control lever (7) to the idle position. Position the rolling pin on the conveyor belt surface opposite the sheet between support and conveyor belt (Figure –a2-). Set the adjustment handle (11) to the required final thickness. Via the control lever (7) start the sheet moving again towards the rolling pin. As soon as the sheet reaches the rolling pin, help it to wrap round the rolling pin half a turn; it will then continue on its own and complete the wrapping operation by inertia.
- During the rolling operation, the operator may need to lift one of the two protection grilles (10) to inspect the product or for flour dusting. When the protection grilles are lifted, as described previously in the point “protections” on p.12, the machine will stop. Once you have finished, simply lower the grille and press the start button (8).

Figure –a2-

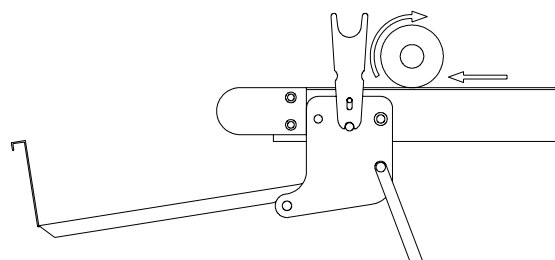

(*) The lever can be easily adjusted to different positions as it engages in a self-locating machined groove, thus making intermediate settings impossible.

4.3 MACHINE CONTROLS

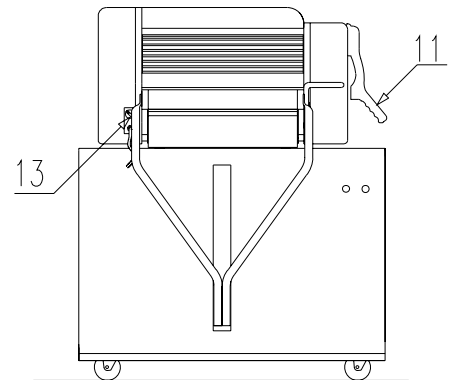
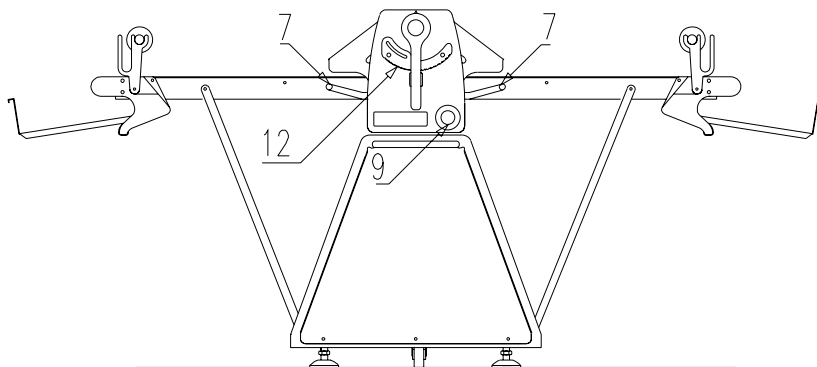

Key:

- 7- Conveyor belt movement control lever
- 9- Start button
- 11- Calibration adjustment handle
- 12- Measurement stop
- 13- Master switch



**USE AND MAINTENANCE MANUAL
MANUAL DOUGH SHEETER
Mod. SPT0/1-E - SPT3/1-E**

Code
3529.0031.01
Revision A
date
06/09/2011

+7(812)987-08-81

5- MAINTENANCE AND CLEANING

5.1 MAINTENANCE

+7(812)987-08-81

Unplug the machine before proceeding with any maintenance or cleaning operation.

Mechanical maintenance



Pict.A3

- Motor belt tension. Once a month check correct tension and condition of the belt.

Electrical maintenance:

- Visually check the power supply cable and plug once a week or whenever it has been rubbed, knocked or trodden on.
- Check correct operation of the safety grille microswitches by opening and closing them during movement.
- In the event of electrical faults, contact qualified personnel.

5.2 CLEANING



- For correct operation and hygiene of the machine, the conveyor belts, steel protections and the four scrapers Figure – a3- must always be cleaned after work.

Figure –a3-



**USE AND MAINTENANCE MANUAL
MANUAL DOUGH SHEETER
Mod. SPT0/1-E - SPT3/1-E**

Code
3529.0031.01
Revision A
date
06/09/2011

- The whole machine must be dusted to prevent accumulation of dirt which could get into the dough.
- For cleaning, use ordinary domestic detergents and rinse thoroughly with water.
- To remove scale, use a plastic scraper or a soft plastic brush.
- Do not use jets of water or compressed air; the former reduces the life of the machine and the latter generates flour dust and is therefore a health hazard.



**USE AND MAINTENANCE MANUAL
MANUAL DOUGH SHEETER
Mod. SPT0/1-E - SPT3/1-E**

Code
3529.0031.01
Revision A
date 06/09/2011

+7(812)987-08-81

6- OPERATING FAULTS

6.1 TROUBLE SHOOTING (812)987-08-81

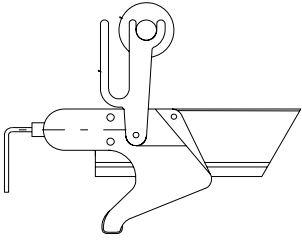
PROBLEM	CAUSE	SOLUTION
With the master switch on (Pos.13 Chap.4.3) and the movement control lever (Pos.7 Chap.4.3) operated, the machine does not work.	<ul style="list-style-type: none"> - The safety grid is open. - The emergency button (Pos.9 Chap.4.3) is on. 	<ul style="list-style-type: none"> - Lower the grid - Release the emergency button.
The conveyor belts veer to one side during movement.	<ul style="list-style-type: none"> - The conveyor belt traction registers are not correctly positioned. Using an Allen key, tighten the adjustment screw at the end of the surface on the side towards which the belts veer. 	
Irregular rotation of conveyor belts with signs of slipping.	<ul style="list-style-type: none"> - Drive belt loose or worn. 	<ul style="list-style-type: none"> - Tighten or replace the belts (see chap. 5.1).



**USE AND MAINTENANCE MANUAL
MANUAL DOUGH SHEETER
Mod. SPT0/1-E - SPT3/1-E**

Code
3529.0031.01
Revision A
date 06/09/2011

vsezip.ru
+7(812)987-08-81

7- SAFETY WARNINGS



**USE AND MAINTENANCE MANUAL
MANUAL DOUGH SHEETER
Mod. SPT0/1-E - SPT3/1-E**

Code
3529.0031.01
Revision A
date
06/09/2011

7.1 SAFETY DEVICES

The function of the safety device is to prevent the operator accidentally inserting his hand in the calibration cylinders during movement, resulting in crushing.

It is made entirely of stainless steel with two metal sheets shaped at the side to prevent access and a set of electrowelded stainless steel rods at the top which prevent the operator inserting his hand but allow him to view the rolling operation. It is surface-treated to facilitate cleaning.

Near the protection rotation fulcrum inside the machine, there is a microswitch which prevents operation of the machine with the protection open or stops the machine immediately if the movable protection is opened with the machine running.

A microswitch is connected to each protection.

7.2 SAFETY AND IDENTIFICATION PLATES



Foto 9

A: HANDS GRIPPING AND DRAGGING HAZARD!
(yellow plate with black drawing and outline)



B: SAFETY DEVICE REMOVAL FORBIDDEN
(white plate with black drawing and red outline)

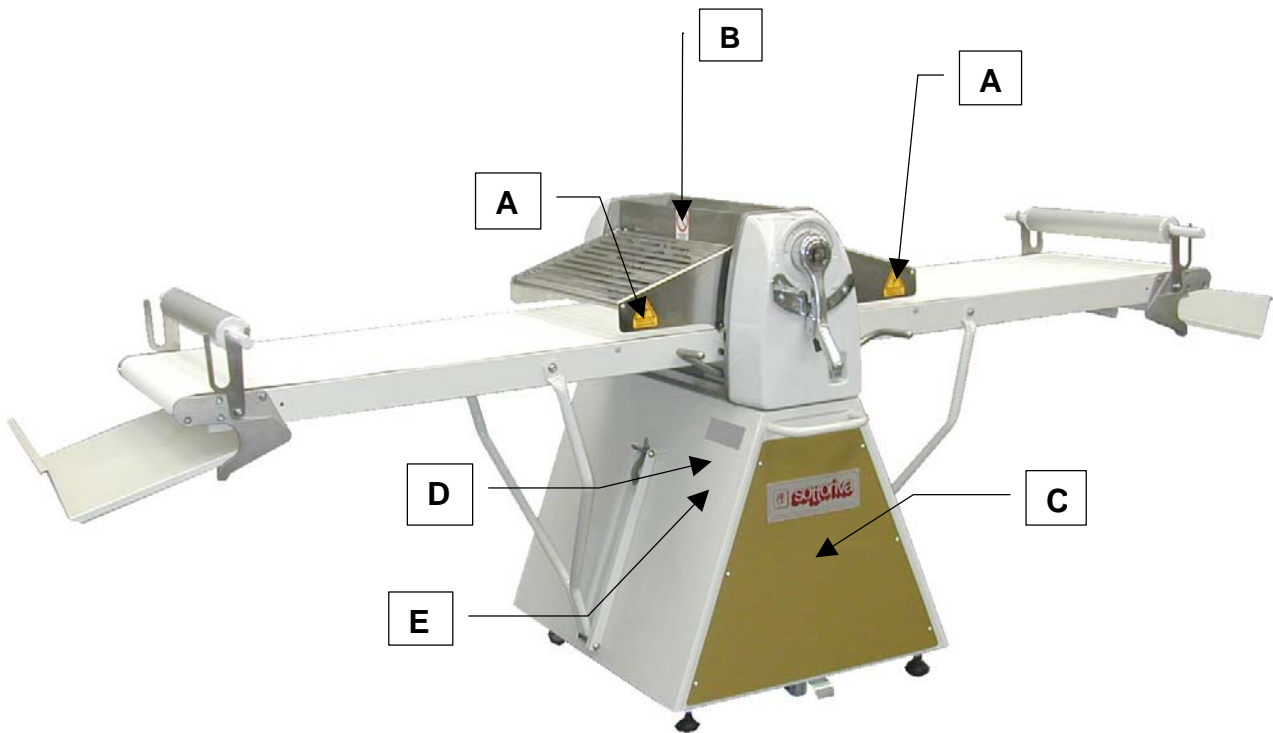
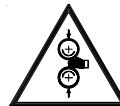

C: FULMINATION HAZARD!
(yellow plate with black drawing and outline)



D:
(red plate with white letters and outline)

MANUAL GREASING THE MOVING PARTS MEANWHILE THE MACHINE IS RUNNING HIGHLY FORBIDDEN

E:
(Blue plate with white letters and outline)

- UNPLUG THE MACHINE BEFORE REMOVING THE SAFETY DEVICES
- REPLACE THE SAFETY DEVICES BEFORE STARTING THE MACHINE

7.3 PROHIBITIONS AND OBLIGATIONS FOR PREVENTION OF ACCIDENTS

Carefully read the warnings below; they provide important information on safety.

- Do not tamper with the safety devices.
- Do not roll frozen products or products other than those described in chap. 1.2.
- Periodically inspect the safety and control devices and keep them in efficient working order.
- Do not install accessories that do not comply with the safety standards.
- In the event of dangerous situations occurring, stop the machine functions via the emergency device and disconnect the power supply via the line selector.



CAUTION

The panels giving access to the internal parts of the machine must not be tampered with, removed and/or opened unless strictly necessary and only by professionally qualified and/or technical support personnel.



**USE AND MAINTENANCE MANUAL
MANUAL DOUGH SHEETER
Mod. SPT0/1-E - SPT3/1-E**

Code
3529.0031.01
Revision A
date 06/09/2011

vsezip.ru
+7(812)987-08-81

8 - SPARE PARTS



**USE AND MAINTENANCE MANUAL
MANUAL DOUGH SHEETER
Mod. SPT0/1-E - SPT3/1-E**

Code
3529.0031.01
Revision A
date
06/09/2011

8.1 INSTRUCTIONS FOR ORDERING

To order spare parts, simply photocopy or copy the form below, fill in and send to us or to your nearest dealer.

Specify reference and description from the lists below.

For electrical components not given in the spare parts lists, specify the code and description provided in the parts list in the electrical documentation.

For large quantities, we will request your authorisation before dispatching the spare parts.

If you wish to order spare parts by telephone, you are advised to fill in the form and dictate it to our customer service department.

SPARE PARTS ORDER FORM

Messrs.

C.M. SOTTORIVA S.p.A.

Via Vittorio Veneto, 63

36035 MARANO VICENTINO (Vicenza) Italy

_____ / ____ / ____

The machine is provided with an identification plate containing the following information:

Model: _____ Serial N°. _____ Volts: _____ Hz _____

and was purchased in the year: _____

Please send us the following spare parts:

POS.	PAGE	DESCRIPTION	QUANTITY

If the order amounts to a large sum, please obtain prior authorisation from us.

NAME _____

ADDRESS _____

TEL. _____ TAX CODE _____

SIGNATURE _____

8.2 PLATE N° 1 - STRUCTURE AND COMPONENTS

+7(812)987-08-81

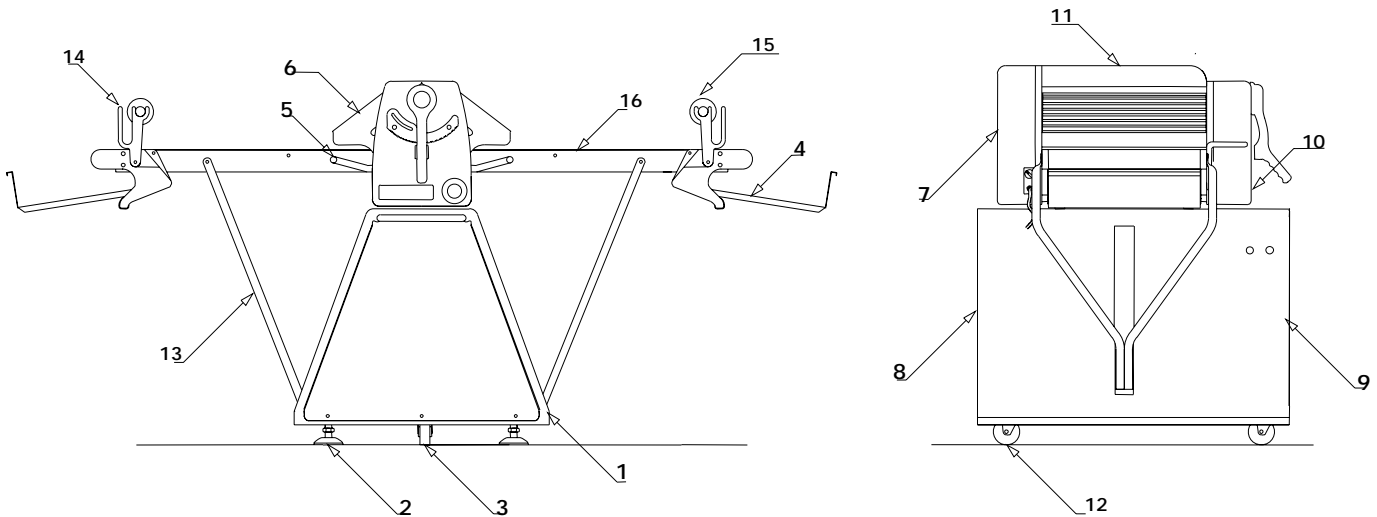

STRUCTURE AND COMPONENTS - REFERENCES

REF.	CODE	DESCRIPTION	REF.	CODE	DESCRIPTION
1	VELM50001	BASE	9	VE1905038	FRONT PANEL
2	0103156	ADJUSTABLE SUPPORT	10	0103119	FRONT CASING
3	0103123	PIVOTING WHEEL	11	0103121	UPPER CASING
4	VE1904104	PRODUCT COLLECTION CONTAINER	12	0103124	FIXED WHEEL
5	LM50002	MOVEMENT CONTROL LEVER	13		TABLES SUPPORT
7	0103120	REAR CASING	14		ROLLER SUPPORTS
8	VE1905038	REAR PANEL	15		ROLLER
			16		BELT

8.3 PLATE N° 2 - PULLEY AND MOTOR UNIT SPT0/1-E -
 SPT3/1-E

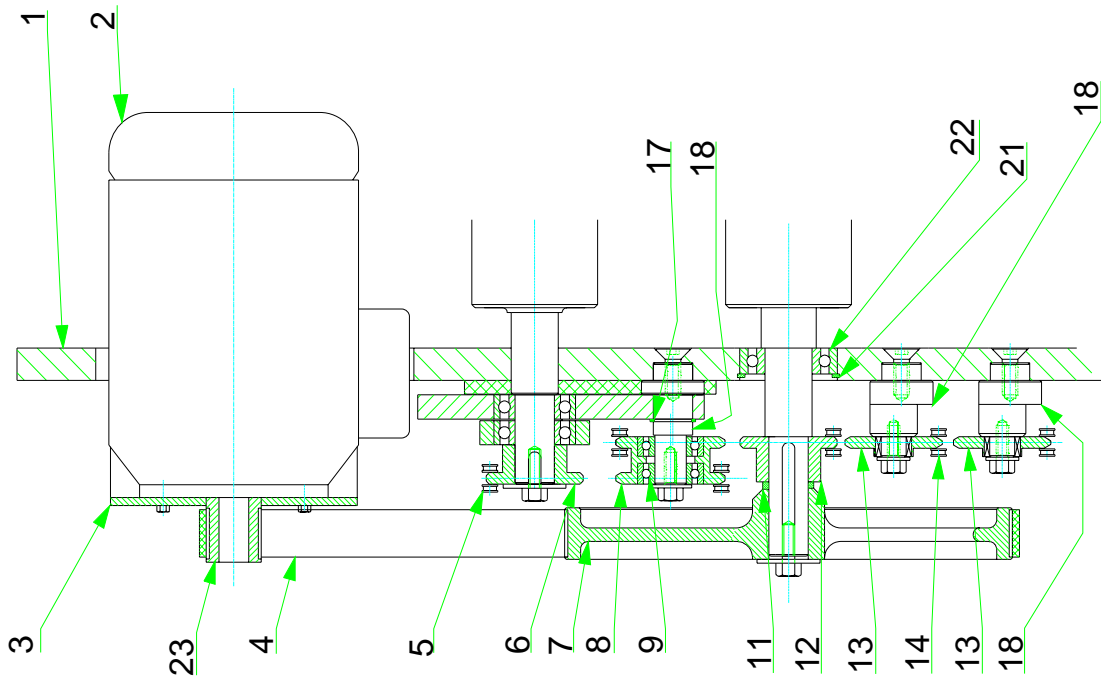
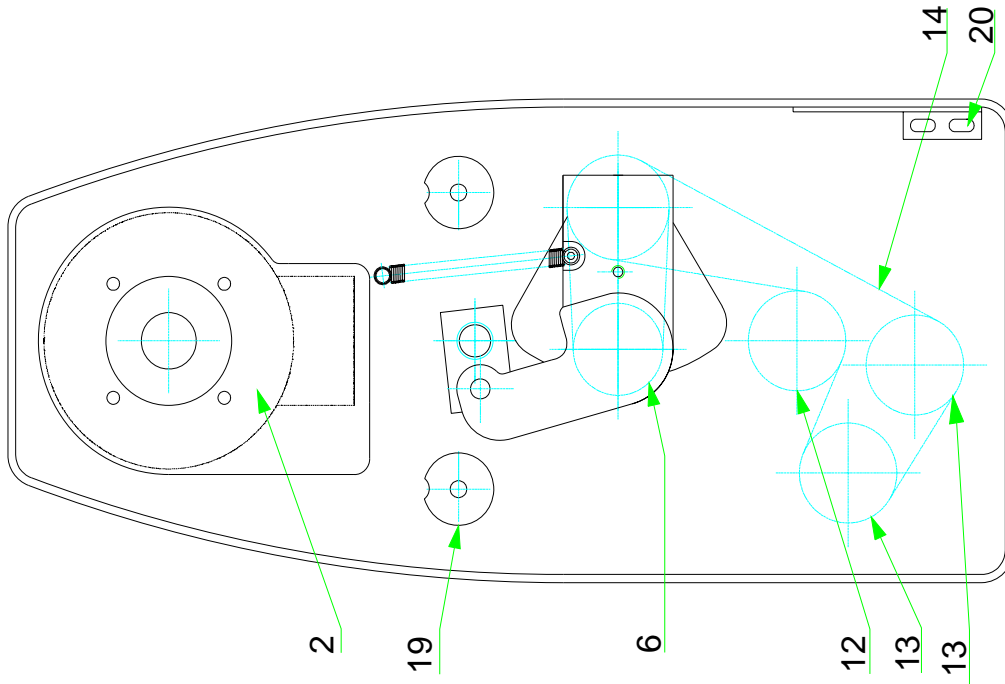



**USE AND MAINTENANCE MANUAL
MANUAL DOUGH SHEETER
Mod. SPT0/1-E - SPT3/1-E**

Code
3529.0031.01
Revision A
date 06/09/2011

PULLEY AND MOTOR UNIT - REFERENCES

REF.	CODE	DESCRIPTION	REF.	CODE	DESCRIPTION
1	FR0301105	SIDE	13	0535002	CHAIN TIGHTENER
2	0801030	ELECTRIC MOTOR	14	0531021	DRIVE CHAIN
5	0533020	DRIVE CHAIN	15	0415001	CIRCLIP
6	0514002	GEAR	16	0101418	PIN
7	FR 0501010	PULLEY	17	0101411	CAM MICROSWITCH
8	FR0511003	GEAR	18	CR 1906050	PLATE
9	0401005	BEARING	19	0415014	CIRCLIP
10			20	0401011	BEARING
11	1004001	SPACERS	21		
12	0514001	GEAR	22		

+7(812)987-08-81

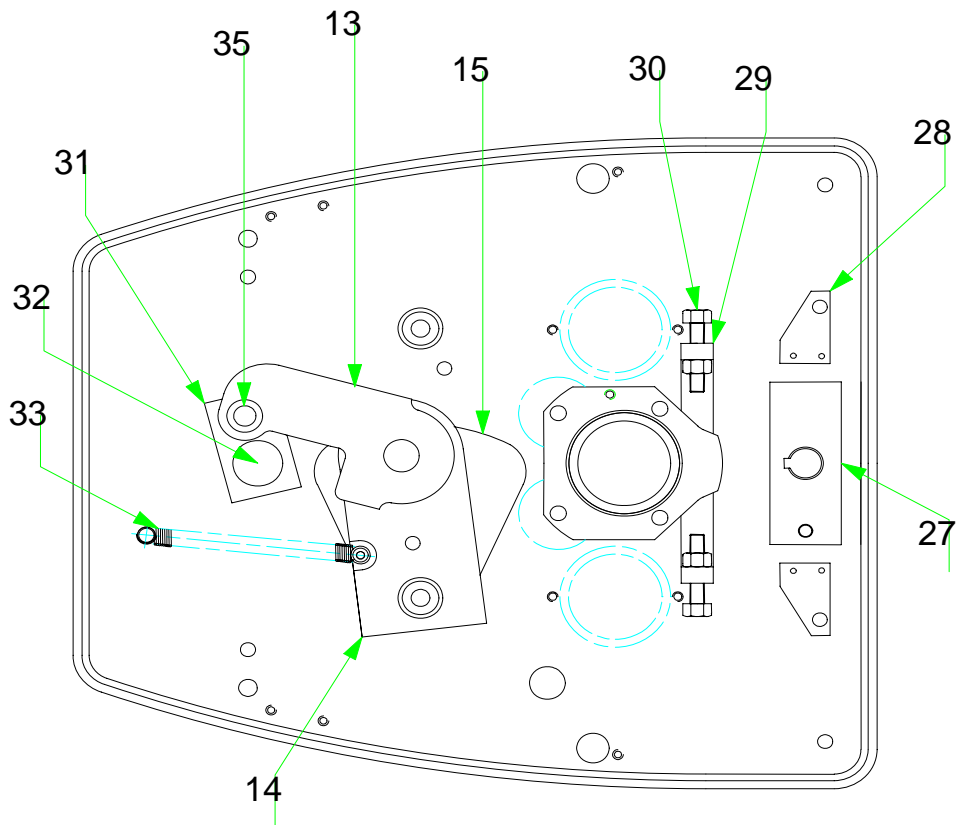

8.5 PLATE N° 4 - HANDLE UNIT

+7(812)987-08-81

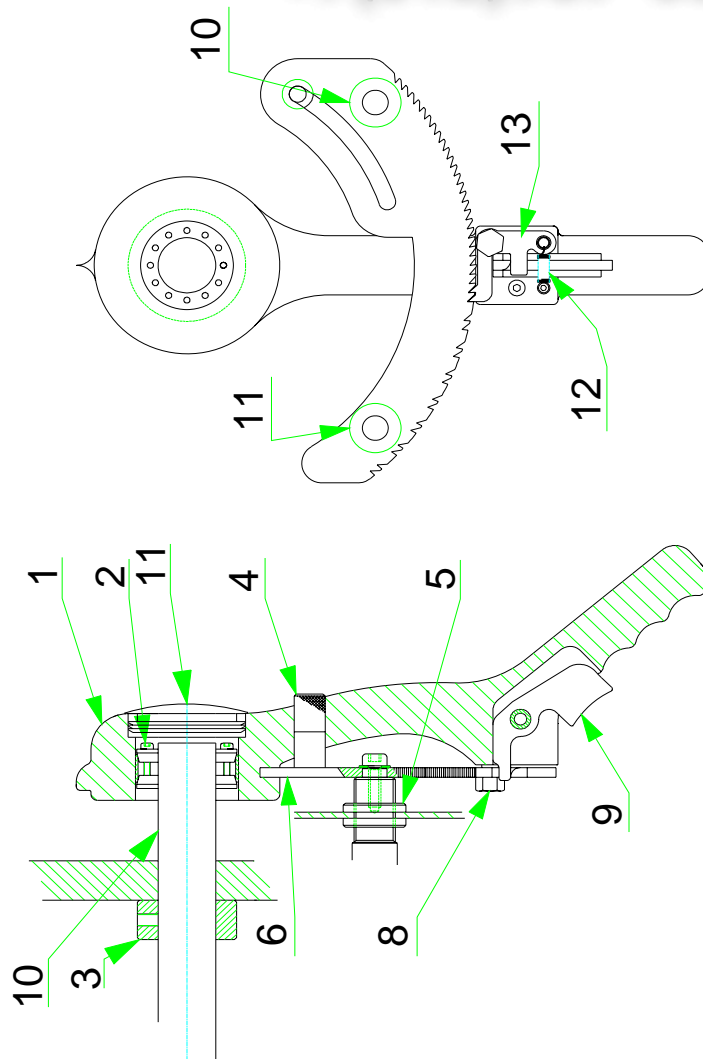

HANDLE UNIT - REFERENCES

REF.	CODE	DESCRIPTION	REF.	CODE	DESCRIPTION
1	LU 0301089	HANDLE	9	CR 1910083	TRIGGER
2	0540001	CENTERING RING	10	0101422	PIN
3	0101499	SPACER 25X13	11	0101541	PIN
4	0101202	MEASURING STOP PIN	12	0202008	SPRING
5	1122001	LOCKING RING NUT	13	1910067	HANDLE CONNECTION
6	CR 1933001	RACK	14	0103129	EXTERNAL PIN
7	0103071	PLUG	15	0101538	TRIGGER RING
8	0101544	SCREW FOR PLATE			

8.6 PLATE N° 5 - CONVEYOR BELT UNIT

+7(812)987-08-81

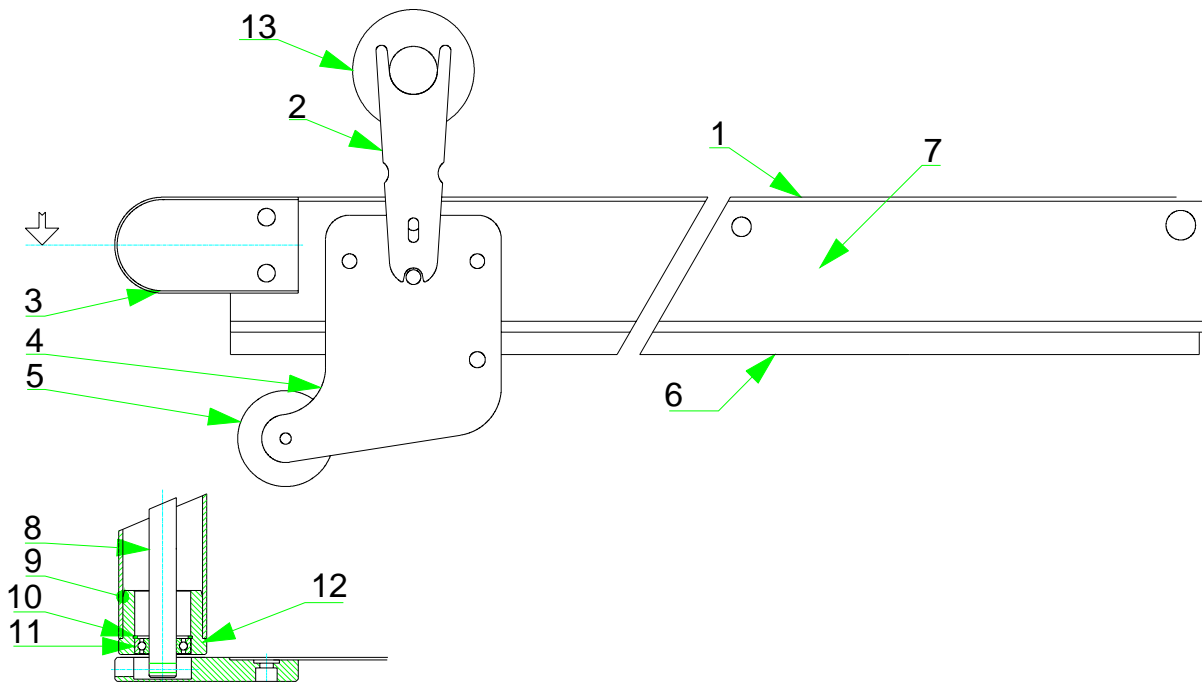

CONVEYOR BELT UNIT - REFERENCES

REF.	CODE	DESCRIPTION	REF.	CODE	DESCRIPTION
1	****	BELT	10	0101466	IDLE ROLLER FLANGE
2	CR1910033	ROLLING PIN HOLDER	9	0415010	CIRCLIP
3	0101107	BELT TIE ROD PLATE	11	0401003	BEARING
4	1918044	UNDERPLATE SUPPORT	12	0103106	SUPPORTING PLATE
5	VE 1904100	CONVEYOR BELT	13	0103129	EXTERNAL PIN
6	ZZMAT001	COMPLETE ROLLING PIN	14	1910099	BELTS SUPPORTING PLATE
7	0101419	IDLE ROLLER	15	0101502	BELT SPACER
8	1222002	IDLE CYLINDRE PIPE	16	1436002	TABLE SUPPORT

(**) BELTS CODES :

- SPT0/1-E code 23 01 014
- SPT0/1-L-E code 23 01 020
- SPT3/1-E code 23 01 022

8.7 TAV. N°7 - SCRAPERS +7(812)987-08-81

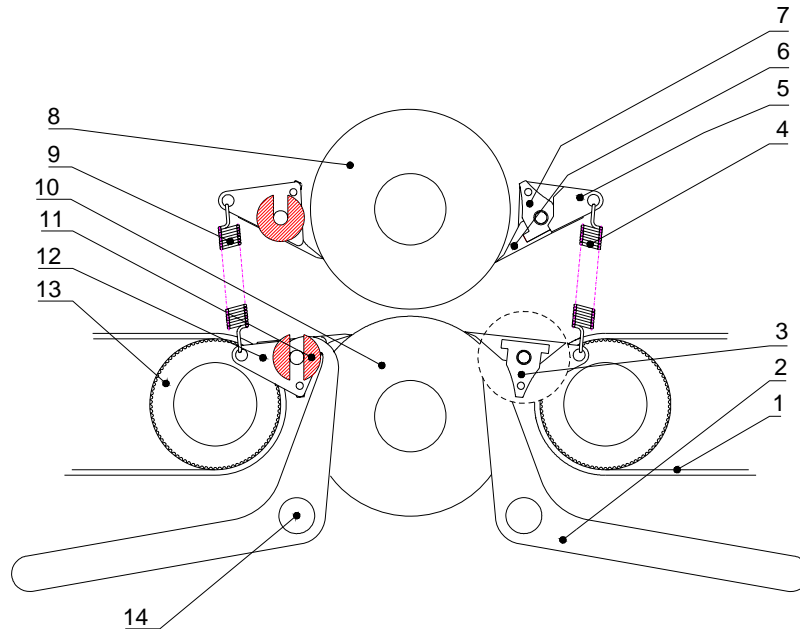

Fig. 12

SCRAPERS GROUP – REFERENCE SPT0/1-E – SPT3/1-E

REF	CODE	DESCRIPTION	REF.	CODE	DESCRIPTION
1	***	BELT	7	0101556	SCRAPER SUPPORT (SPT3/1-E)
2	1913027	SCRAPER STOP	8	CR0101530	UPPER CALIBR. ROLLER
3	0101543	SCRAPER SUPPORT(SPT0/1-E)	9	0202006	SCRAPER SPRING
3	0101555	SCRAPER SUPPORT(SPT3/1-E)	10	CR0101531	LOWER CALIBR.ROLLER
4	0202005	SCRAPERS SPRING	11	0101416	LOWER SCRAPER PIN
5	1913028	SPRING SEAT	12	1913028	SPRING SEAT
6	0103106	SCRAPING KNIFE (SPT0/1-E)	13	LM60005	COMPLETE DRIVING ROLL
6	0103133	SCRAPING KNIFE (SPT3/1-E)	14	0101424	REVOLUTION PIN
7	0101542	SCRAPER SUPPORT (SPT0/1-E)			

8.8 TAV. N° 7 – BASEMENT GROUP

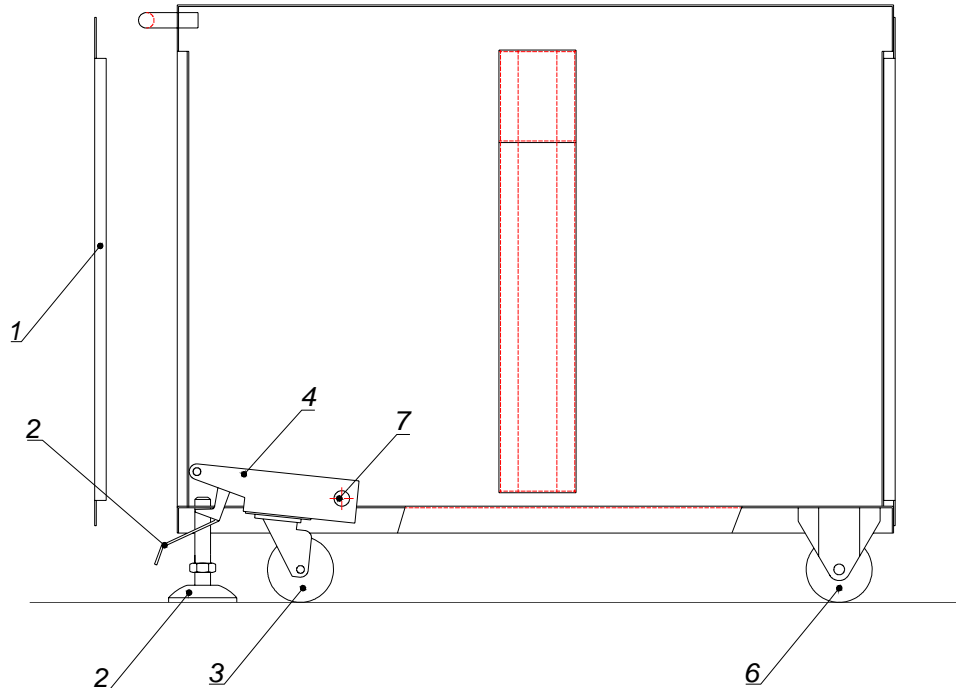

Fig. 13

GRUPPO BASAMENTO – RIFERIMENTI (Riferimento fig. 13)

REF	CODE	DESCRIPTION	REF.	CODE	DESCRIPTION
1	VE1904115	SIDE PANEL	6	0103124	FIXED WHEEL
2	0103156	ADJUSTABLE SUPPORT	7	0101545	PIN
3	0103123	MOVING WHEEL	8		
4	VE1906055	WHEEL HOLDING PLATE	9		
5	1906064	BLOCKING PEDAL	10		

vsezip.ru

+7(812)987-08-81

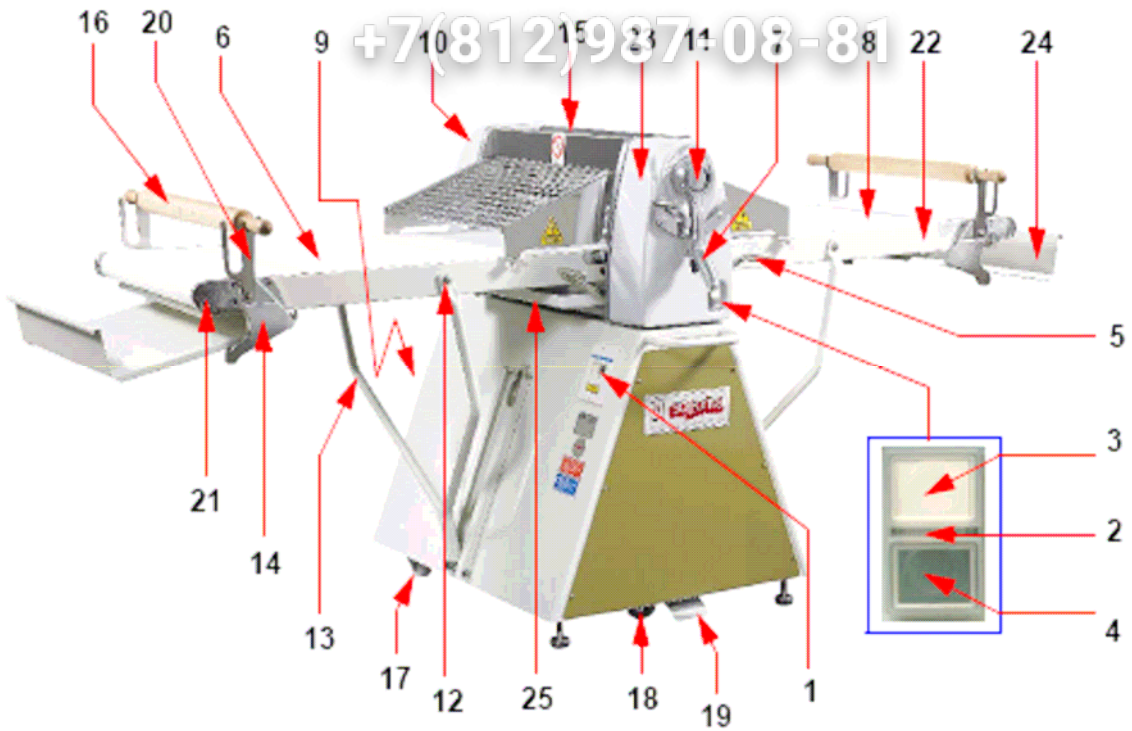

Photo 10

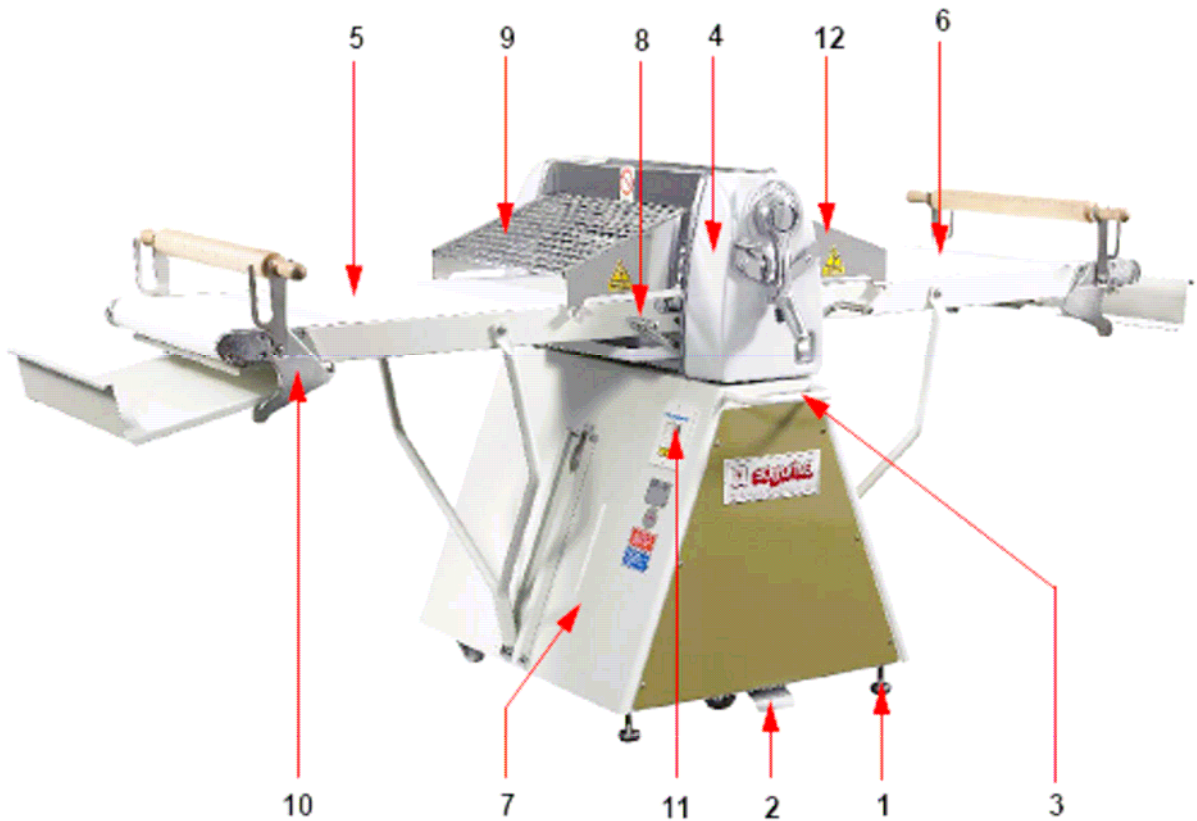

Photo 11

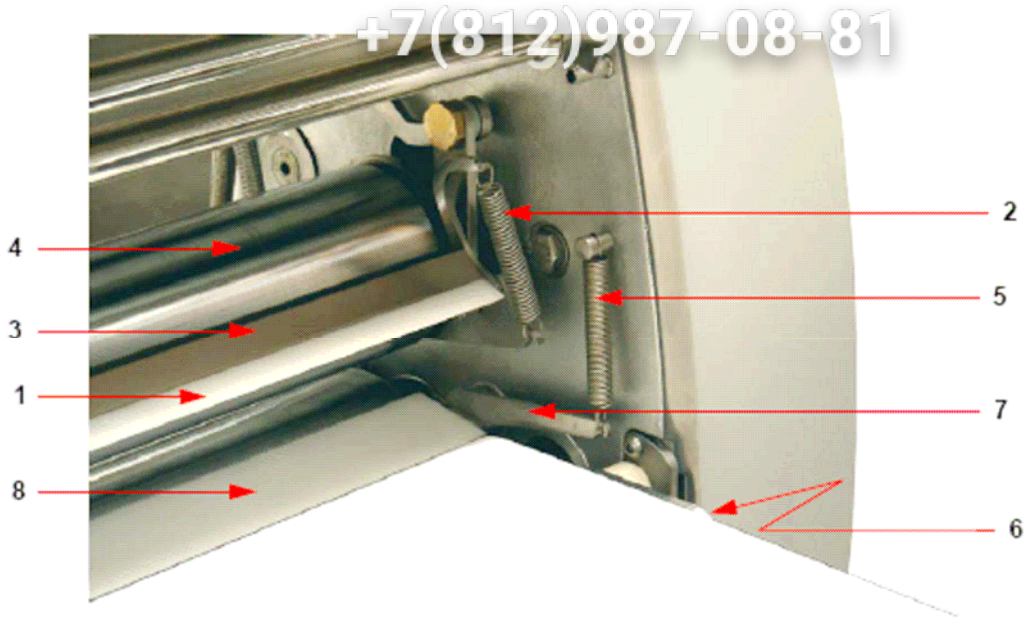

Photo 12

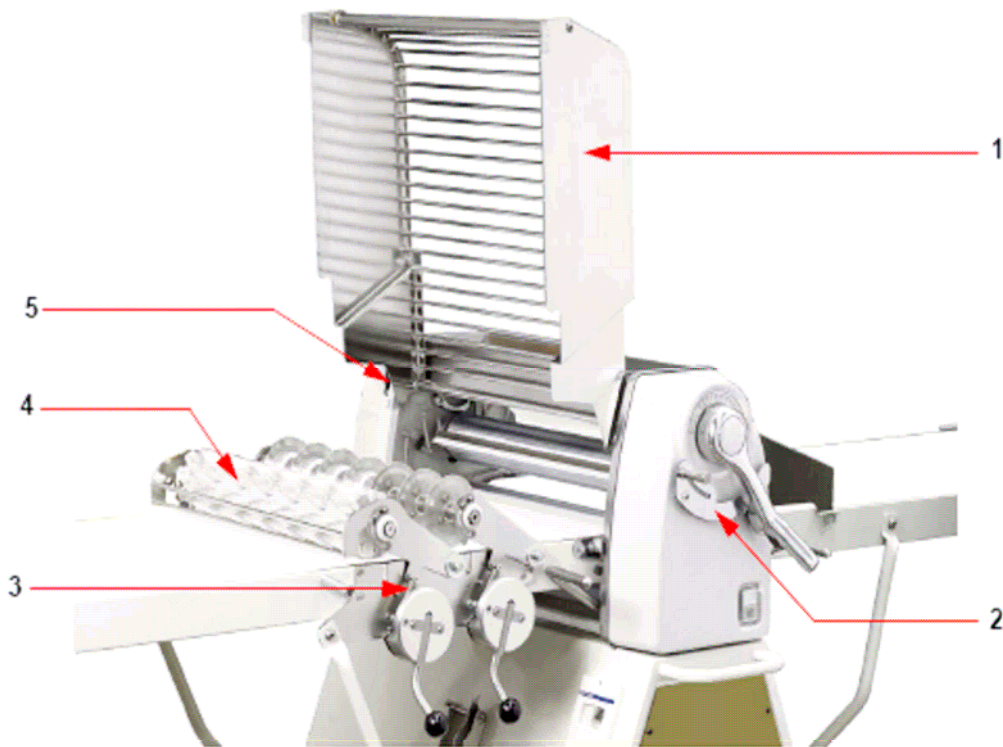

Photo 13

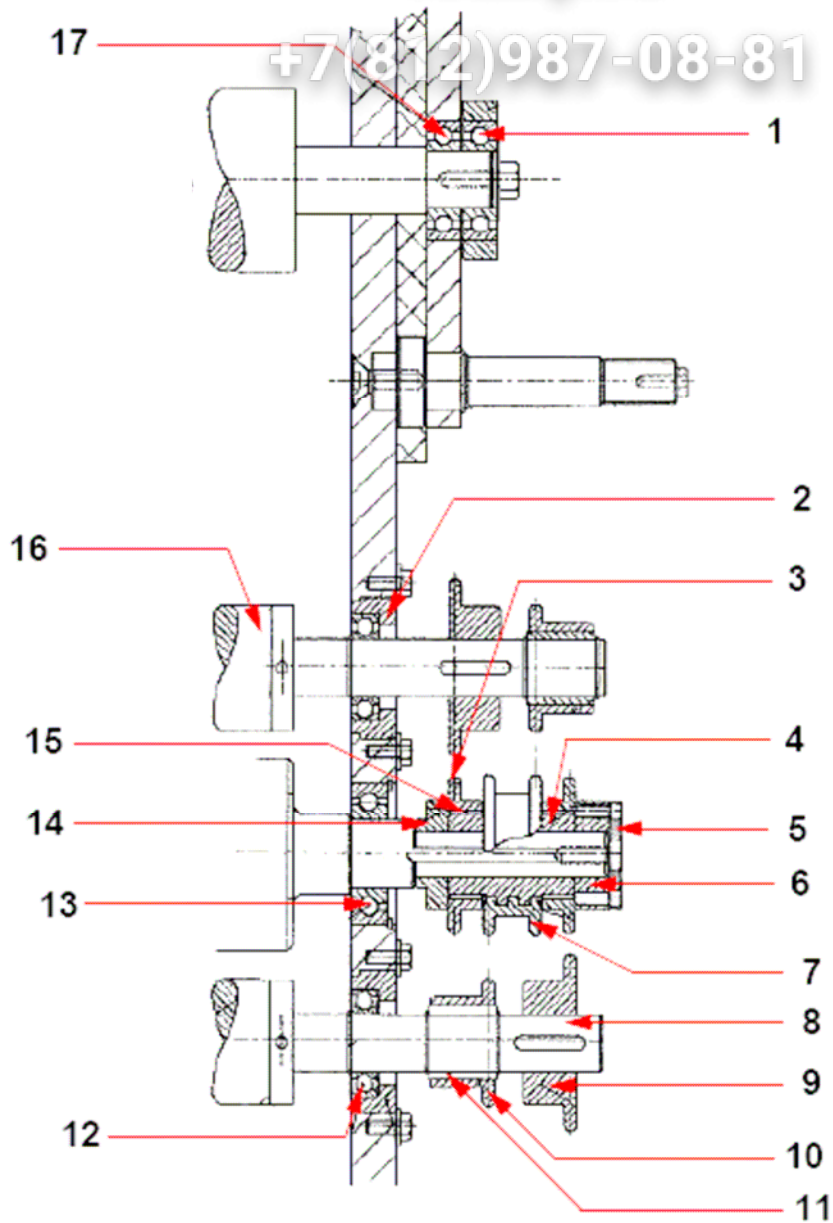

Photo 14



**USE AND MAINTENANCE MANUAL
MANUAL DOUGH SHEETER
Mod. SPT0/1-E - SPT3/1-E**

Code
3529.0031.01
Revision A
date
06/09/2011

8.9 ADVISABLE SPARE PARTS

Ref.	Photo	DESCRIPTION	SPT0/1 Code	SPT3/1 Code
6-8	10	Conveyor belt L 750	36000820	-
6-8	10	Conveyor belt L 1000	36000821	36000822
6-8	10	Conveyor belt L 1200	-	36000972
6-8	10	Conveyor belt L 1400	-	36000810
6-8	10	Conveyor belt L 1600	-	36000823
16	10	Rolling pin	30460045	30470010
1	12	Upper scraper only plastic (No. 2)	38061647	38061648
8	12	Bottom scraper only plastic (No. 2)	38061647	38061648
2-5	12	Spring for scraper (No. 8)	31900028	31900028
17	10	Fixed wheel	24070028	24070028
18	10	Revolving wheel	24070063	24070063
19	10	Pedal kit	38061785	38061785
3	13	Spring croissants device (optional)	-	38061787
5	13	Gas spring of croissants protection device (optional)	-	38061789
10	11	Final support	38062004	38062004
20	10	Rolling pin support	38062005	38062005
21	10	Cylinder tighten belt	38061893	38061894
22	10	Sliding floor belt L 750	38062020	-
22	10	Sliding floor belt L 1000	38062021	38062022
22	10	Sliding floor belt L 1200	-	38062023
22	10	Sliding floor belt L 1400	-	38062024
22	10	Sliding floor belt L 1600	-	38062025
-	-	Plate under sliding floor belt 1000	-	38062019
-	-	Plate under sliding floor belt 1200	-	38062006
-	-	Plate under sliding floor belt 1400	-	38062007
13	10	Leg support plan	38061837	38061836



USE AND MAINTENANCE MANUAL
MANUAL DOUGH SHEETER
Mod. SPT0/1-E - SPT3/1-E

Code
3529.0031.01
Revision A
date 06/09/2011

Ref.	Photo	DESCRIPTION	SPT0/1 Code	SPT3/1 Code
1	14	Bearing	24006004	24006004
2	14	Flange	38062037	38062037
3	14	Pinion	38062034	38062034
4	14	Core	38062033	38062033
5	14	Washer	38062032	38062032
6	14	Cover	38062031	38062031
7	14	Double pinion	38061875	38061875
8	14	Cylinder drive belt	38061957	38061955
9	14	Pinion	38062029	38062029
10	14	Pinion	38061876	38061876
11	14	Free wheel (No. 2)	38062027	38062027
12	14	Bearing (No. 2)	24006004	24006004
13	14	Bearing	24006148	24006148
14	14	Bush	38062036	38062036
15	14	Bush	38062035	38062035
16	14	Cylinder drive belt	38061956	38061846
17	14	Bearing	24006044	24006044



**USE AND MAINTENANCE MANUAL
MANUAL DOUGH SHEETER
Mod. SPT0/1-E - SPT3/1-E**

Code
3529.0031.01
Revision A
date
06/09/2011

+7(812)987-08-81

9- ACCESSORIES ON REQUEST

(FOR SPT3/1-E ONLY)



**USE AND MAINTENANCE MANUAL
MANUAL DOUGH SHEETER
Mod. SPT0/1-E - SPT3/1-E**

Code
3529.0031.01
Revision A
date 06/09/2011

9.1 2-SPEED MACHINE FOR CUTTING DEVICE APPLICATION

9.2 ROLLERS HOLDER FOR DOUGH CUTTING

9.3 ROLLERS WITH VARIOUS SIZES AND SHAPES



**USE AND MAINTENANCE MANUAL
MANUAL DOUGH SHEETER
Mod. SPT0/1-E - SPT3/1-E**

Code
3529.0031.01
Revision A
date
06/09/2011

+7(812)987-08-81

10- ELECTRICAL EQUIPMENT

10.1 DESCRIPTION

+7(812)987-08-81

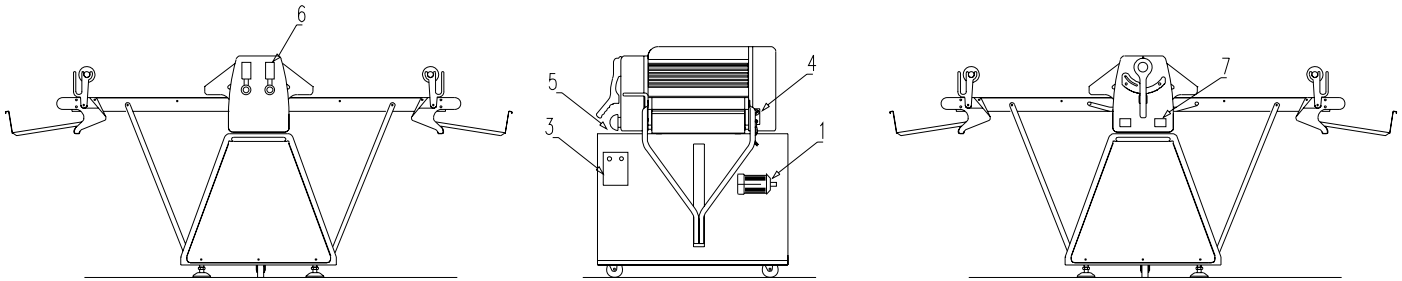

The electrical equipment consists of:

1. Electric motor for machine movement.
- 2.
3. magnetic switch for motor safety.
4. main switch.
5. start/stop button
6. Two safety grid opening microswitches.
7. Two movement control lever microswitches.

– A set of suitably protected cables for connection of the various utilities and safety devices:

10.2 DOCUMENTATION

The documentation comprises:

- Circuit diagram with data necessary for choosing the type, specifications, rated current and adjustments of the protection device against overcurrents which must be installed at the origin of the power supply cable.
- Layout diagram of the equipment contained in the housings (Pos. 1 and 2).
- Operating diagram of terminals.
- List of parts.



CAUTION

These documents must be reserved exclusively for professionally qualified and/or technical support personnel.

Зип Общепит

vsezip.ru

+7(812)987-08-81

Зип Общепит

vsezip.ru

+7(812)987-08-81

Зип Общепит

vsezip.ru

+7(812)987-08-81