

Зип Общепит

vsezip.ru

DESPIECE TECNICO

+7(812)987-08-81

Lavavasos
Lave-verres
Glass-washer
Glasperspülmaschinen
Lavabicchieri
Lavacopos

Modelos:

LVC-12
LVC-15
LVC-21
LVC-15 D
LVC-21 D
LVC-21 B
LVC-21 C
LVC-21 W

Junio 2009 June

Revisado Julio 2013 July Revised



F A G O R I N D U S T R I A L

Зип Общепит

vsezip.ru

+7(812)987-08-81

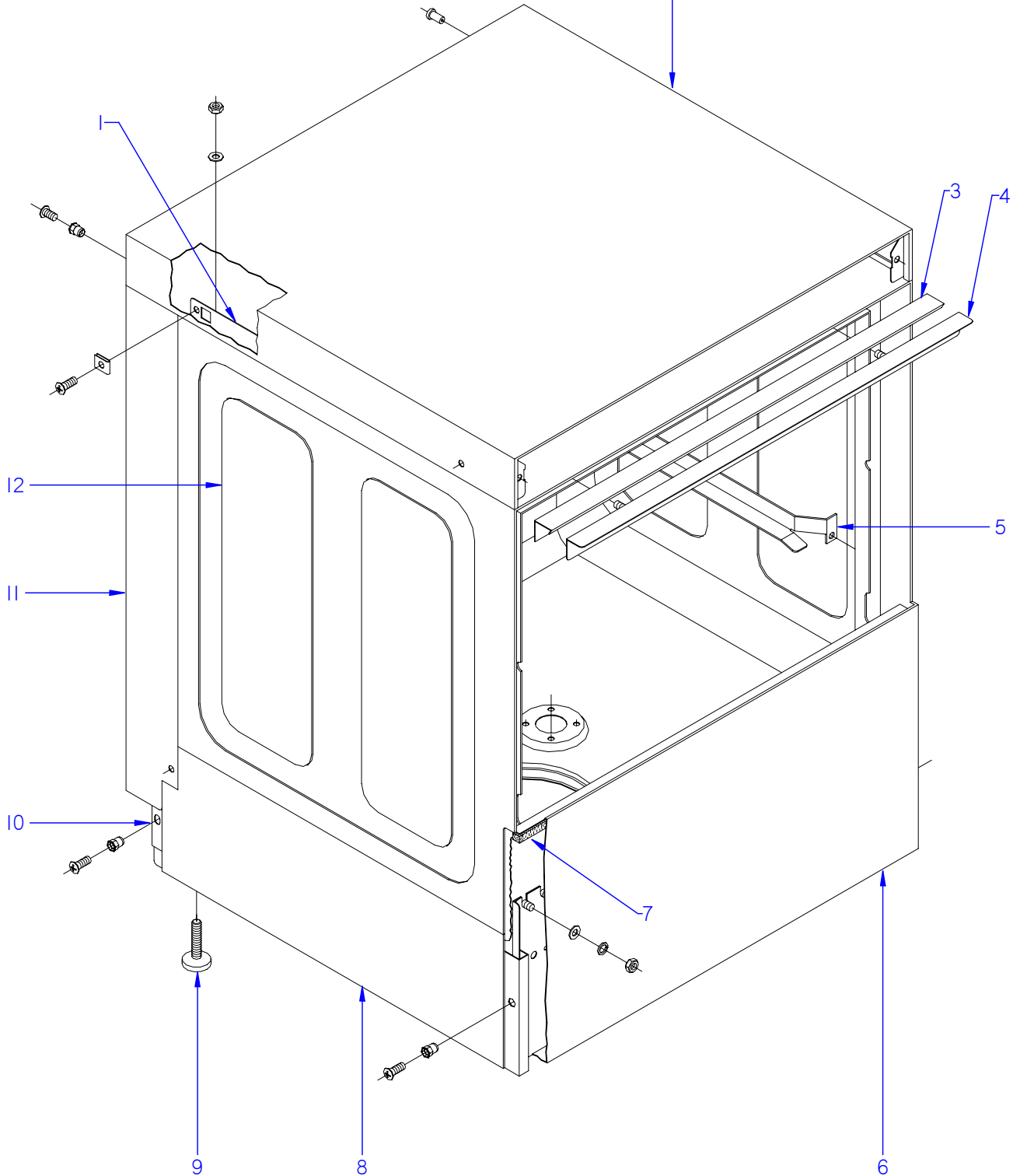

ITEM MARCADO EN COLOR = REPUESTO RECOMENDADO
COLOURED ITEM = RECOMMENDED SPARE PART

N plano	Firma	Fecha	Aparato	MUEBLE	Lamina	Fagor Industrial S.Coop. FAGOR
C-2110	<i>[Signature]</i>	2009-10	LAVAVASOS LVC		1	Oñate

MOD.		LAVAVASOS		ZONA		MUEBLE				
ITEM	CODIGO	DENOMINACION	TEXTO	LVC-12	LVC-15	LVC-15D	LVC-21	LVC-21D		
1	Z410309000	ESCUADRA AMARRE TAPA 12-15	FASTENING BRACKET COVER TA	2	2	2	-	-		
1	Z410317000	ESCUADRA AMARRE TAPA 12-15	FASTENING BRACKET COVER TA	2	2	2	-	-		
1	Z420318000	ESCUADRA AMARRE TAPA 21	COVER FASTENING BRACKET 21	-	-	-	2	2		
1	Z420319000	ESCUADRA AMARRE TAPA 21	COVER FASTENING BRACKET 21	-	-	-	2	2		
	Q232040000	ARANDELA A6	WASHER A6	4	4	4	4	4		
	Q162040000	TUERCA EXAGONAL M6	HEXAGONAL NUT M6	4	4	4	4	4		
	Q221012000	TUERCA RAPIDA M,5	RAPID NUT M,5	6	6	6	6	6		
2	Z402904000	TAPA R10-14-C12-15	COVER R10-14-C12-15	1	1	1	-	-		
2	Z422904000	TAPA R20-C21	COVER R20-C21	-	-	-	1	1		
	Q152004000	TORNILLO APLASTADO M5x13 A304	FLAT HEADED BOLT M5x13 A304	10	10	10	10	10		
3	Z400315000	PERFIL CAJA	BOX PROFILE	1	1	1	-	-		
3	Z420315000	PERFIL CAJA	BOX PROFILE	-	-	-	1	1		
4	Z400306000	ESCUADRA SUJECCION PERFIL	FASTENING BRACKET PROFILE	1	1	1	-	-		
4	Z420306000	ESCUADRA SUJECCION PERFIL	FASTENING BRACKET PROFILE	-	-	-	1	1		
	Q232040000	ARANDELA A6	WASHER A6	2	2	2	2	2		
	Q162040000	TUERCA EXAGONAL M6	HEXAGONAL NUT M6	2	2	2	2	2		
5	Z410304000	GUIA CESTILLO DERECHA C12-15	RIGHT BASKET GUIDE C12-15	1	1	1	-	-		
5	Z440304000	GUIA CESTILLO DERECHA	RIGHT BASKET GUIDE	-	-	-	1	1		
S/Nº	Z410303000	GUIA CESTILLO IZQUIERDA C12-15	LEFT BASKET GUIDE C12-15	1	1	1	-	-		
S/Nº	Z440303000	GUIA CESTILLO IZQUIERDA	LEFT BASKET GUIDE	-	-	-	1	1		
	Q232040000	ARANDELA A6	WASHER A6	4	4	4	4	4		
	Q162040000	TUERCA EXAGONAL M6	HEXAGONAL NUT M6	4	4	4	4	4		
6	Z468611000	PANEL FRONTAL10-12-14-15 NEU	FRONT PANEL10-12-14-15 NEU	1	1	1	-	-		
6	Z448611000	PANEL FRONTAL C21	FRONT PANEL C21	-	-	-	1	1		
6	Z458611000	PANEL FRONTAL 21B	FRONT PANEL 21B	-	-	-	-	-		
7	Z400309000	PERFIL INFERIOR CAJA	BOX LOWER PROFILE	1	1	1	-	-		
7	Z420309000	PERFIL INFERIOR CAJA	BOX LOWER PROFILE	-	-	-	1	1		
8	Z468720000	ARMAZON COMPLETO	COMPLETE FRAME	1	1	1	-	-		
8	12046711	ARMAZON COMPLETO LVC-12	COMPLETE FRAME LVC-12	1	1	1	-	-		
8	Z420101000	ARMAZON COMPLETO	COMPLETE FRAME	-	-	-	1	1		
8	12046707	ARMAZON COMPLETO LVC-21	COMPLETE FRAME LVC-21	-	-	-	1	1		

MOD. ZONA vsezip.ru

ITEM	CODIGO	DENOMINACION	TEXTO	LVC-12	LVC-15	LVC-15D	LVC-21	LVC-21D
9	Z200107000	PATA REGULABLE	ADJUSTABLE LEG	4	4	4	4	4
10	Z402908000	PANEL POSTERIOR INFERIO. 1-4-2-5	LOWER REAR PANEL. 1-4-2-5	1	1	1	-	-
10	Z422908000	PANEL POSTERIOR INFERIOR 20-21	LOWER REAR PANEL 20-21	-	-	-	1	1
	Q152004000	TORNILLO APLASTADO M5x13 A304	FLAT HEADED BOLT M5x13 A304	3	3	3	3	3
11	Z402902000	PANEL POSTERIOR A R-10 C-12	REAR PANEL A R-10 C-12	1	1	1	-	-
11	Z422902000	PANEL POSTERIOR R20-C21	REAR PANEL R20-C21	-	-	-	1	1
12	Z468730000	CAJA SOLDADA LVC-12/15	WELDED BOX LVC-12/15	1	1	-	-	-
12	Z480311000	CAJA SOLDADA LVC-15D	WELDED BOX LVC-15D	-	-	1	-	-
12	Z448730000	CAJA SOLDADA LVC-21	WELDED BOX LVC-21	-	-	-	1	-
12	Z500311000	CAJA SOLDADA LVC-21D	WELDED BOX LVC-21D	-	-	-	-	1
12	Z440311000	CAJA SOLDADA LVC-21B	WELDED BOX LVC-21B	-	-	-	-	-
12	Z458411000	CAJA SOLDADA LVC-21W	WELDED BOX LVC-21W	-	-	-	-	-
	Q162040000	TUERCA EXAGONAL M6	HEXAGONAL NUT M6	8	8	8	8	8
	Q232040000	ARANDELA A6	WASHER A6	8	8	8	8	8
	Q262040000	ARANDELA GROW. A6 A.304	WASHER GROW. A6 A.304	8	8	8	8	8

Зип Общепит

vsezip.ru

+7(812)987-08-81

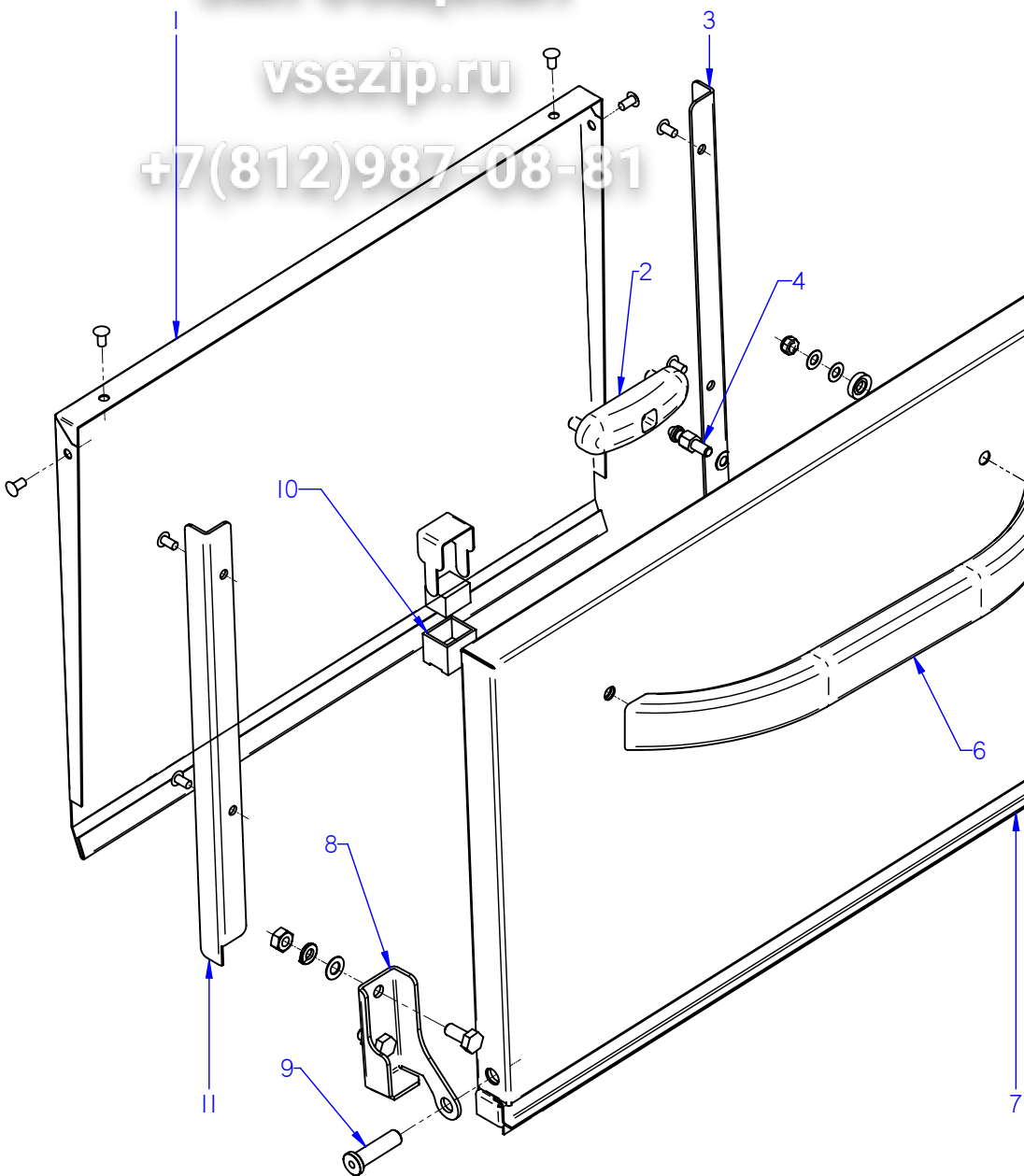

ITEM MARCADO EN COLOR = REPUUESTO RECOMENDADO
COLOURED ITEM = RECOMMENDED SPARE PART

N plano	Firma	Fecha	Aparato	Lamina	Fagor Industrial S. Coop.
C-2111	<i>(Signature)</i>	2009-10	LAVAVASOS LVC	2	Onete



MOD.		LAVAVASOS		ZONA		PUERTA				
ITEM	CODIGO	DENOMINACION	TEXTO	LVC-12	LVC-15	LVC-15D	LVC-21	LVC-21D		
	1200002010	KIT PUERTA LAVAVASOS 12-15	DOOR KIT 12-15 GLASSWASH.	1	1	1	-	-		
	1200002020	KIT PUERTA LAVAVASOS 21	DOOR KIT 21 GLASSWASHER	-	-	-	1	1		
1	Z400511000	CONTRAPUERTA COMPLETA	COMPLETE DOOR REVERSE	1	1	1	-	-		
1	Z420513000	CONTRAPUERTA COMPL. R20-C21	COMPL. DOOR REVERSE R20-C21	-	-	-	1	1		
	Q412000000	REMACHE TUBULAR 4 x 8	TUBULAR RIVET 4 x 8	4	4	4	4	4		
2	Z200607000	CONJUNTO CIERRE PUERTAT-CO	LOCK UNIT PUERTAT-CO	1	1	1	1	1		
	Q222012000	TUERCA AUTOBLOCANTE M6	SELF-LOCKING NUT M6	2	2	2	2	2		
3	Z400521000	GUIA DERECHA	RIGHT GUIDE	1	1	1	-	-		
3	Z420521000	GUIA DERECHA	RIGHT GUIDE	-	-	-	1	1		
4	Z200601000	ENGANCHE CIERRE	LOCK LATCH	1	1	1	1	1		
5	Z400515000	BISAGRA DERECHA T-C.	RIGHT HINGE T-C.	1	1	1	1	1		
	Q012042000	TORNILLO EXAGONAL M6X15	HEXAGONAL BOLT M6x15	2	2	2	2	2		
	Q232040000	ARANDELA A6	WASHER A6	2	2	2	2	2		
	Q262040000	ARANDELAGROW. A6 A.304	WASHER GROW. A6 A.304	2	2	2	2	2		
	Q162040000	TUERCA EXAGONAL M6	HEXAGONAL NUT M6	2	2	2	2	2		
6	Z400542000	ASA LVS.	HANDLE LVS.	1	1	1	1	1		
	Q032032000	TORNILLO ALOMADO M5X15	CURVED SCREW M5X15	2	2	2	2	2		
	Q308002000	ARANDELA DUBO A6 NYLON	WASHER DUBO A6 NYLON	2	2	2	2	2		
7	Z468004000	PUERTA COMPLETA EDESA	COMPLETE DOOR EDESA	1	1	1	-	-		
7	Z448003000	PUERTA COMPLETA EDESA	COMPLETE DOOR EDESA	-	-	-	1	1		
S/Nº	Z206135000	CHECK LIST LAVAVAJILLAS FAGOR	CHECK LIST	1	1	1	1	1		
8	Z400514000	BISAGRA IZQUIERDA T-C.	LEFT HINGE T-C.	1	1	1	1	1		
	Q012042000	TORNILLO EXAGONAL M6X15	HEXAGONAL BOLT M6x15	2	2	2	2	2		
	Q262040000	ARANDELAGROW. A6 A.304	WASHER GROW. A6 A.304	2	2	2	2	2		
	Q162040000	TUERCA EXAGONAL M6	HEXAGONAL NUT M6	2	2	2	2	2		
9	Z400516000	EJE PUERTA	DOOR SHAFT	2	2	2	2	2		
10	Z200506000	IMAN	MAGNET	-	1	1	1	1		
	Z200507000	PROTECTOR IMAN	MAGNET PROTECTOR	-	1	1	1	1		
11	Z400522000	GUIA IZQUIERDA	LEFT GUIDE	1	1	1	-	-		
11	Z420522000	GUIA IZQUIERDA	LEFT GUIDE	-	-	-	1	1		
	Q412000000	REMACHE TUBULAR 4 x 8	TUBULAR RIVET 4 x 8	2	2	2	2	2		

Зип Общепит

vsezip.ru

+7(812)987-08-81

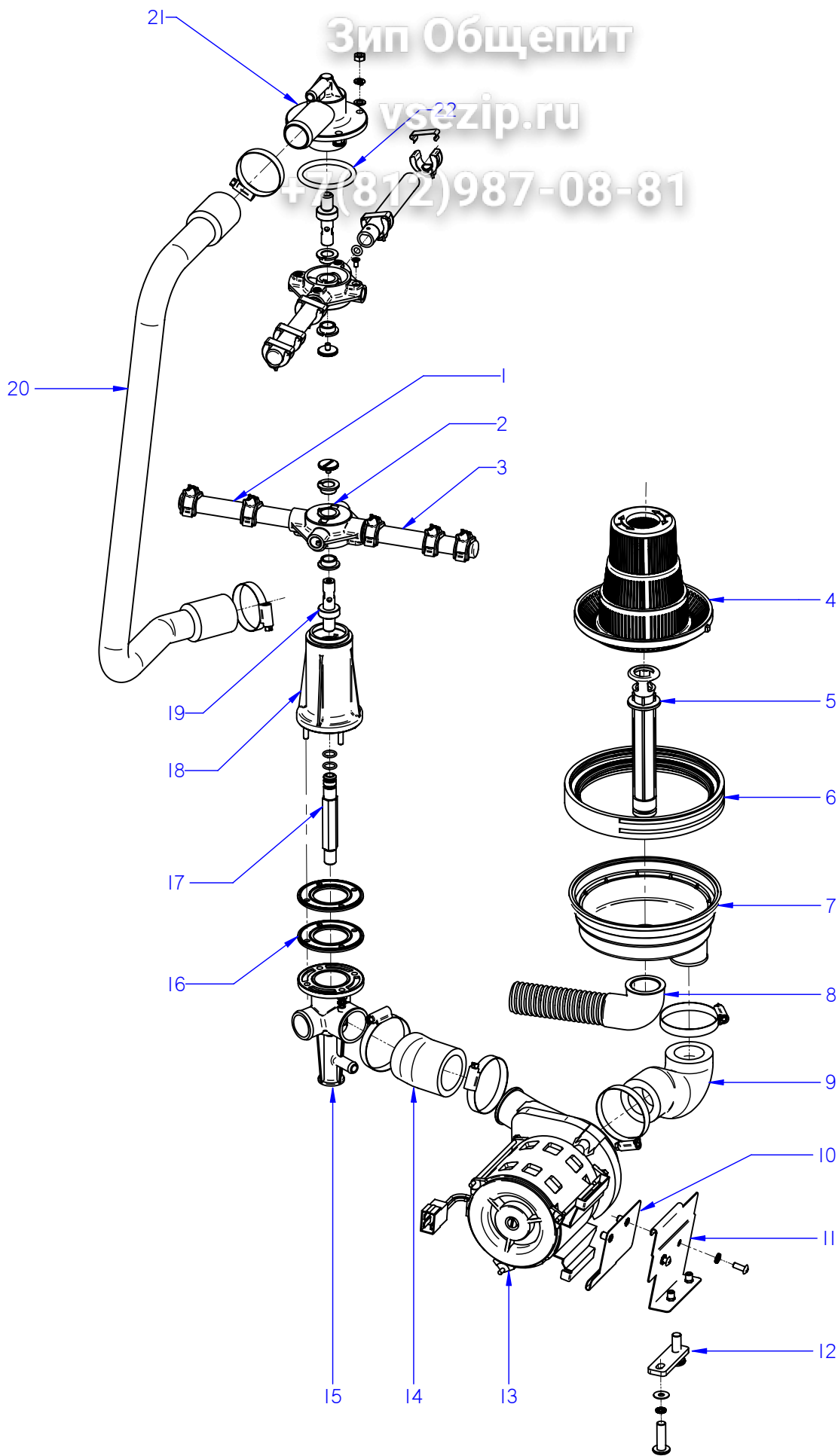

ITEM MARCADO EN COLOR = REPUESTO RECOMENDADO
COLOURED ITEM = RECOMMENDED SPARE PART

N plano	Firma	Fecha	Aparato	CONJUNTO FUNCIONAL LAVADO LAVAVASOS LVC	Lamina	Fagor Industrial S.Coop. FAGOR
C-2112	<i>[Signature]</i>	2009-10			3	Oñate

MOD.	LAVAVASOS	ZONA	CONJUNTO FUNCIONAL LAVADO					
ITEM	CODIGO	DENOMINACION	TEXTO	LVC-12	LVC-15	LVC-15D	LVC-21	LVC-21D
1	Z460701000	RAMA LAVADO B	WASH B BRANCH	2	2	2	—	—
1	Z440707000	RAMA LAVADO B	WASH B BRANCH	—	—	—	2	2
	Z400709000	TOBERA LAVADO	WASH NOZZLE	4	4	4	6	6
	Z400711000	ENGANCHE TOBERA LAVADO	WASH NOZZLE CATCH	4	4	4	6	6
2	Z410704000	CRUCETA	CROSSPIECE	2	2	2	2	2
	Q152016000	TORNILLO ESPECIAL M.5X0.8	SPECIAL BOLT M.5X0.8	2	2	2	2	2
	Z410705000	CASQUILLO CRUCETA	CROSSPIECE BUSHING	4	4	4	4	4
3	Z460702000	RAMA LAVADO A	WASH BRANCH A	2	2	2	—	—
3	Z440706000	RAMA LAVADO A	WASH BRANCH A	—	—	—	2	2
	Z400709000	TOBERA LAVADO	WASH NOZZLE	6	6	6	6	6
	Z400711000	ENGANCHE TOBERA LAVADO	WASH NOZZLE CATCH	6	6	6	6	6
4	Z400920000	FILTRO ALTO	HIGH FILTER	1	1	1	1	1
5	Z400907000	ALIVIADERO	OVERFLOW	1	1	1	1	1
S/Nº	12010282	JUNTA TORICA 25.4X20.2X2.6	O-RING 25.4X20.2X2.6	1	1	1	1	1
6	Z400902000	JUNTA CUBETA	TRAY SEAL	1	1	1	1	1
7	Z400901000	CUBETA	TRAY	1	1	1	1	1
	Z400903000	ABRAZADERA CUBETA	TRAY CLAMP	1	1	1	1	1
8	Z400908000	MANGUERA DESAGÜE	DRAINAGE HOSE	1	1	1	1	1
	Q901307000	ABRAZADERA ELASTICA 37.7-39.7	ELASTIC CLAMP 37.7-39.7	1	1	1	1	1
9	Z400905000	CODO ASPIRACION 1003115	EXTRACTOR ELBOW 1003115	1	1	1	1	1
	Q881307000	ABRAZADERA 40-60	CLAMP 40-60	2	2	2	2	2
10	Z401004000	AMARRE MOTOBOMBA	MOTORPUMP FASTENING	1	1	1	1	1
11	Z401002000	SOPORTE MOTOBOMBA	MOTOR PUMP SUPPORT	1	1	1	—	—
11	Z421002000	SOPORTE MOTOBOMBA	MOTOR PUMP SUPPORT	—	—	—	1	1
	Q152004000	TORNILLO APLASTADO M5x13 A304	FLAT HEADED BOLT M5x13 A304	2	2	2	2	2
	Q242030000	ARANDELA ABANICO A5 A.304	FAN WASHER A5 A.304	2	2	2	2	2
12	Z401006000	PERFIL AMORTIGUADOR	SHOCK ABSORBER PROFILE	1	1	1	1	1
	Q302022000	ARANDELA 16x6x1,2 A304	WASHER 16x6x1.2 A304	2	2	2	2	2
	Q032032000	TORNILLO ALOMADO M5X15	CURVED SCREW M5X15	2	2	2	2	2
13	Z401001000	BOMBA LAVADO	WASH PUMP	1	1	1	1	1
	Z401001100	TURBINA BOMBA Z401001	TURBINE PUMP Z401001	1	1	1	1	1

MOD.	LAVAVASOS	ZONA	CONJUNTO FUNCIONAL LAVADO
-------------	------------------	-------------	----------------------------------

ITEM	CODIGO	DENOMINACION	TEXTO	LVC-12	LVC-15	LVC-15D	LVC-21	LVC-21D
14	Z400906000	CODO IMPULSION 1003116	IMPULSE ELBOW 1003116	1	1	1	1	1
	Q881307000	ABRAZADERA 40-60	CLAMP 40-60	2	2	2	2	2
15	Z410702000	PASAMUROS CESTO CUADRADO	SQUARE BASKET WALL BUSHING	1	1	1	1	1
	Q232030000	ARANDELA A5	WASHER A5	4	4	4	4	4
	Q262030000	ARANDELA GROW. A5 A.304	WASHER GROW. A5 A.304	4	4	4	4	4
	Q162030000	TUERCA EXAGONAL M5	HEXAGONAL NUT M5	4	4	4	4	4
16	Z400703000	JUNTA ESTANQUE. 1003113	SEAL. 1003113	2	2	2	2	2
17	Z410712000	EMPALME ACLARADO	RINSE CONNECTION	1	1	1	1	1
	Q307056000	JUNTA TORICA 10,82x14,38x1,78	O-RING 10.82x14.38x1.78	2	2	2	2	2
18	Z410701000	SOPORTE INFERIOR CUADRO	LOWER SUPPORT BRACKET	1	1	1	1	1
19	Z410708000	EJE	SHAFT	2	2	2	2	2
20	Z410711000	ARBOL LAVADO	WASH CAM	1	1	1	-	-
20	Z440711000	ARBOL LAVADO	WASH CAM	-	-	-	1	1
	Q881306000	ABRAZADERA 32-50L	CLAMP 32-50L	2	2	2	2	2
21	Z410703000	SOPORTE DISTRIB. SUPERIOR	UPPER DISTRIB. SUPPORT	1	1	1	1	1
	Q232040000	ARANDELA A6	WASHER A6	4	4	4	4	4
	Q262040000	ARANDELA GROW. A6 A.304	WASHER GROW. A6 A.304	4	4	4	4	4
	Q162040000	TUERCA EXAGONAL M6	HEXAGONAL NUT M6	4	4	4	4	4
22	Q307052000	JUNTA TORICA 50,17X60,83X5,3	O-RING 50.17X60.83X5.3	1	1	1	1	1

Зип Общепит

sezip.ru

+7(812)987-08-81

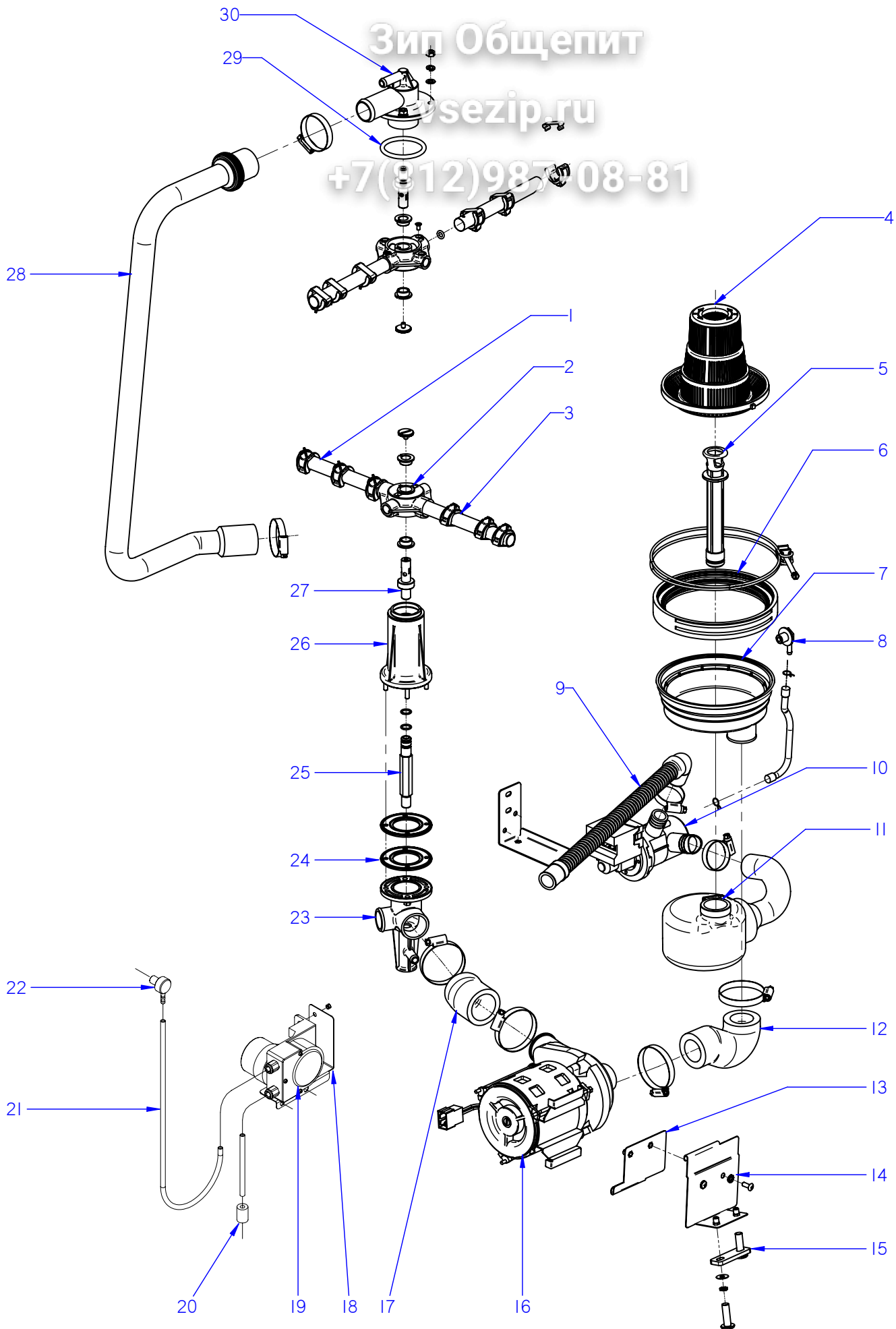

ITEM MARCADO EN COLOR = REPUESTO RECOMENDADO
COLOURED ITEM = RECOMMENDED SPARE PART

N plano	Firma	Fecha	Aparato	CONJUNTO FUNCIONAL LAVADO	Lamina	Fagor Industrial S.Coop. FAGOR
C-2113	<i>[Signature]</i>	2009-10	LAVAVASOS LVC-21B / 21C / 21W		4	Oñate

MOD.	LAVAVASOS	ZONA	CONJUNTO FUNCIONAL LAVADO					
ITEM	CODIGO	DENOMINACION	TEXTO	LVC-21B	LVC-21C	LVC-21W		
1	Z440707000	RAMA LAVADO B	WASH B BRANCH	2	2	2		
	Z400709000	TOBERA LAVADO	WASH NOZZLE	6	6	6		
	Z400711000	ENGANCHE TOBERA LAVADO	WASH NOZZLE CATCH	6	6	6		
2	Z410704000	CRUCETA	CROSSPIECE	2	2	2		
	Q152016000	TORNILLO ESPECIAL M.5X0.8	SPECIAL BOLT M.5X0.8	2	2	2		
	Z410705000	CASQUILLO CRUCETA	CROSSPIECE BUSHING	4	4	4		
3	Z440706000	RAMA LAVADO A	WASH BRANCH A	2	2	2		
	Z400709000	TOBERA LAVADO	WASH NOZZLE	6	6	6		
	Z400711000	ENGANCHE TOBERA LAVADO	WASH NOZZLE CATCH	6	6	6		
4	Z400920000	FILTRO ALTO	HIGH FILTER	1	1	1		
5	Z400907000	ALIVIADERO	OVERFLOW	1	1	1		
5	12047160	ALIVIADERO LVS MOD. B	OVERFLOW LVS MOD. B	1	1	1		
S/Nº	12010282	JUNTA TORICA 25.4X20.2X2.6	O-RING 25.4X20.2X2.6	1	1	1		
6	Z400902000	JUNTA CUBETA	TRAY SEAL	1	1	1		
7	Z400901000	CUBETA	TRAY	1	1	1		
	Z400903000	ABRAZADERA CUBETA	TRAY CLAMP	1	1	1		
8	Z230905000	PASAMUROS INOX DETERGENTE	INOX DETERGENT WALL BUSHIN	1	2	1		
	P102154000	BRIDA ELASTICA TUBO	ELASTIC PIPE FLANGE	2	2	2		
	3702400000	TUBO GOMA NEGRO D 8*4	BLACK RUBBER PIPE Ø 8*4	1	1	1		
9	Z220903000	MANGUERA DESAGÜE	DRAINAGE HOSE	1	1	1		
	Q901307000	ABRAZADERA ELASTICA 37.7-39.7	ELASTIC CLAMP 37.7-39.7	1	1	1		
10	Z220901000	BOMBA DESAGUE 30W	DRAINAGE PUMP 30W	1	1	—		
10	Z223501000	BOMBA DE DESAGUE 30W 60HZ	DRAINAGE PUMP 30W 60HZ	1	1	1		
	Z430902000	SOPORTE BOMBA DESAGUE B	DRAINAGE PUMP SUPPORT B	1	1	1		
	Q012031000	TORNILLO EXAGONAL M5X10	HEXAGONAL BOLT M5x10	4	4	4		
	Q242030000	ARANDELA ABANICO A5 A.304	FAN WASHER A5 A.304	4	4	4		
11	Z430901000	ACUMULADOR 1503114	ACCUMULATOR 1503114	1	1	1		
	Q901307000	ABRAZADERA ELASTICA 37.7-39.7	ELASTIC CLAMP 37.7-39.7	2	2	2		
12	Z400905000	CODO ASPIRACION 1003115	EXTRACTOR ELBOW 1003115	1	1	1		
	Q881307000	ABRAZADERA 40-60	CLAMP 40-60	2	2	2		
13	Z401004000	AMARRE MOTOBOMBA	MOTORPUMP FASTENING	1	1	1		

MOD.		LAVAVASOS		ZONA		CONJUNTO FUNCIONAL LAVADO			
ITEM	CODIGO	DENOMINACION	TEXTO	LVC-21B	LVC-21C	LVC-21W			
14	Z421002000	SOPORTE MOTOBOMBA	MOTOR PUMP SUPPORT	1	1	1			
	Q152004000	TORNILLO APLASTADO M5x13 A304	FLAT HEADED BOLT M5x13 A304	2	2	2			
	Q242030000	ARANDELA ABANICO A5 A.304	FAN WASHER A5 A.304	2	2	2			
15	Z401006000	PERFIL AMORTIGUADOR	SHOCK ABSORBER PROFILE	1	1	1			
	Q242030000	ARANDELA ABANICO A5 A.304	FAN WASHER A5 A.304	2	2	2			
	Q302022000	ARANDELA 16x6x1,2 A304	WASHER 16x6x1.2 A304	2	2	2			
	Q032032000	TORNILLO ALOMADO M5X15	CURVED SCREW M5X15	2	2	2			
16	Z401001000	BOMBA LAVADO	WASH PUMP	1	1	1			
	Z401001100	TURBINA BOMBA Z401001	TURBINE PUMP Z401001	1	1	1			
17	Z400906000	CODO IMPULSION 1003116	IMPULSE ELBOW 1003116	1	1	1			
	Q881307000	ABRAZADERA 40-60	CLAMP 40-60	2	2	2			
18	Z208909000	SOPORTE DOSIF. DETERGENTE	DETERGENT DISP. SUPPORT	—	1	1			
	Q419005000	REMACHE 4X8 ALMG3 / ALUMINIO	RIVET 4X8 ALMG3 / ALUMINIUM	—	2	2			
19	Z208903000	DOSIFIC. DGTE REGULABLE G300	DETERGENT DISP. ADJUST. G30	—	1	1			
	Q012031000	TORNIL. EXAGONAL M5X10 A.304	HEX BOLT M5X10 A.304	—	2	2			
	Q232030000	ARANDELA A5	WASHER A5	—	2	2			
20	Z701152000	PESO FILTRO	FILTER WEIGHT	—	1	1			
21	Z448614000	CONDUCTO ASPIRACIÓN	EXTRACTOR PIPE	—	1	1			
22	Z208914000	PASAMUROS INOX DETERGENTE	INOX DETERGENT WALL BUSHIN	—	1	1			
	Q306024000	JUNTA Ø18X12.5X1.5	SEAL Ø18X12.5X1.5	—	1	1			
	Q162070000	TUERCA EXAGONAL M12	HEXAGONAL NUT M12	—	1	1			
S/Nº	Z208904000	CABLEADO DOSIFICADOR DTGTE.	DETERGENT DISP. WIRING	—	1	1			
23	Z410702000	PASAMUROS CESTO CUADRADO	SQUARE BASKET WALL BUSHIN	1	1	1			
	Q232030000	ARANDELA A5	WASHER A5	4	4	4			
	Q262030000	ARANDELA GROW. A5 A.304	WASHER GROW. A5 A.304	4	4	4			
	Q162030000	TUERCA EXAGONAL M5	HEXAGONAL NUT M5	4	4	4			
24	Z400703000	JUNTA ESTANQUE. 1003113	SEAL. 1003113	2	2	2			
25	Z410712000	EMPALME ACLARADO	RINSE CONNECTION	1	1	1			
	Q307056000	JUNTA TORICA 10,82x14,38x1,78	O-RING 10.82x14.38x1.78	2	2	2			
26	Z410701000	SOPORTE INFERIOR CUADRO	LOWER SUPPORT BRACKET	1	1	1			
27	Z410708000	EJE	SHAFT	2	2	2			

MOD.	LAVAVASOS	ZONA	CONJUNTO FUNCIONAL LAVADO
------	------------------	------	----------------------------------

+7(812)987-08-81

ITEM	CODIGO	DENOMINACION	TEXTO	LVC-21B	LVC-21C	LVC-21W		
28	Z440711000	ARBOL LAVADO	WASH CAM	1	1	1		
	Q881306000	ABRAZADERA 32-50L	CLAMP 32-50L	2	2	2		
29	Q307052000	JUNTA TORICA 50,17X60,83X5,3	O-RING 50.17X60.83X5.3	1	1	1		
30	Z410703000	SOPORTE DISTRIB. SUPERIOR	UPPER DISTRIB. SUPPORT	1	1	1		
	Q232040000	ARANDELA A6	WASHER A6	4	4	4		
	Q262040000	ARANDELA GROW. A6 A.304	WASHER GROW. A6 A.304	4	4	4		
	Q162040000	TUERCA EXAGONAL M6	HEXAGONAL NUT M6	4	4	4		

Зип Общепит

vsezip.ru

+7(812)987-08-81

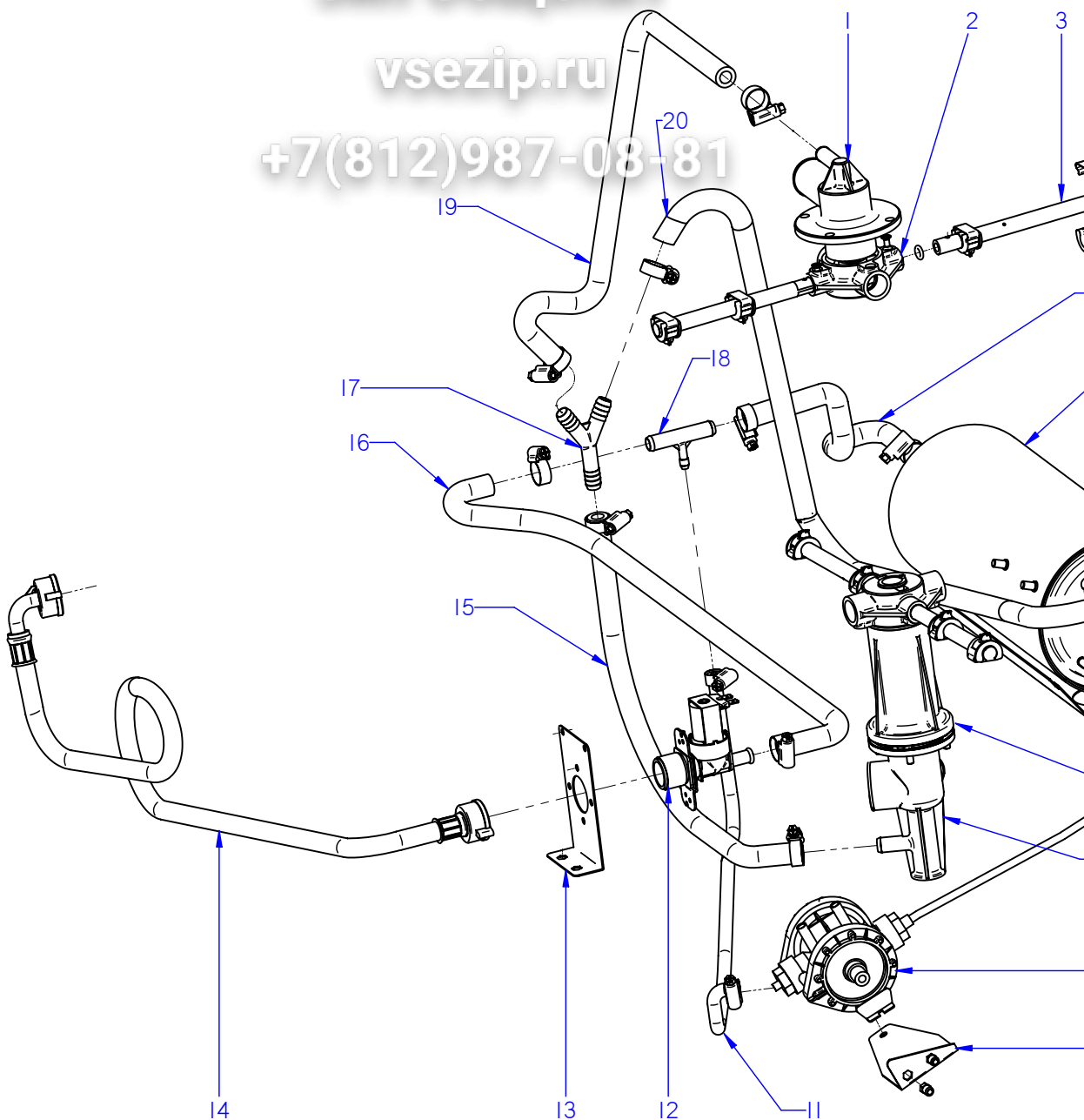

ITEM MARCADO EN COLOR = REPUESTO RECOMENDADO
COLOURED ITEM = RECOMMENDED SPARE PART

N plano	Firma	Fecha	Aparato	Lamina	Fogor Industrial S. Coop. FOGOR Oñate
C-21114	<i>[Signature]</i>	2009-10	CONJUNTO FUNCIONAL ACILARADO LAVAVASOS LVC-12	5	

MOD.	LAVAVASOS	ZONA	CONJUNTO FUNCIONAL ACLARADO				
ITEM	CODIGO	DENOMINACION	TEXTO	LVC-12			
1	Z410703000	SOPORTE DISTRIBUIDOR SUPER.	UPPER DISTRIBUTION SUPPORT	1			
	Q232040000	ARANDELA A6	WASHER A6	4			
	Q262040000	ARANDELA GROW. A6 A.304	WASHER GROW. A6 A.304	4			
	Q162040000	TUERCA EXAGONAL M6	HEXAGONAL NUT M6	4			
2	Z410704000	CRUCETA	CROSSPIECE	2			
	Q152016000	TORNILLO ESPECIAL M.5X0.8	SPECIAL BOLT M.5X0.8	2			
	Z410705000	CASQUILLO CRUCETA	CROSSPIECE BUSHING	4			
3	Z461901000	RAMA ACLARADO B	RINSE BRANCH B	2			
S/Nº	Z461902000	RAMA ACLARADO A	RINSE BRANCH A	2			
	Z201905000	TOBERA ACLARADO	RINSE NOZZLE	8			
	Z201906000	ENGANCHE TOB. ACLA.19728	NOZZLE LATCH RINSE.19728	8			
	Q307036000	JUNTA TORICA 5,28X8,84X1,78	O-RING 5.28X8.84X1.78	8			
	Q042021000	TORNILL. AVELLANADO M4X10 A304	COUNTERSUNK BOLT M4X10 A304	4			
4	3676900000	TUBO GOMA NEGRA Ø17*10	BLACK RUBBER PIPE Ø17*10	1			
	Q881302000	ABRAZADERA 12/20	CLAMP 12/20	2			
5	12022893	CALDERIN LAVAVASOS 10-2	GLASSWASHER BOILER 10-2	1			
6	Z701152000	PESO FILTRO	FILTER WEIGHT	1			
7	Z410701000	SOPORTE INFERIOR CUADRO	LOWER SUPPORT BRACKET	1			
8	Z410702000	PASAMUROS CESTO CUADRADO	SQUARE BASKET WALL BUSHING	1			
	Q232030000	ARANDELA A5	WASHER A5	4			
	Q262030000	ARANDELA GROW. A5 A.304	WASHER GROW. A5 A.304	4			
	Q162030000	TUERCA EXAGONAL M5	HEXAGONAL NUT M5	4			
9	Z211109000	DOSIFICADOR TENSOACTIVO N-6	SURFACE ACT. DISP. N-6	1			
9	12045206	DOSIFICADOR_ABRILLANTADOR_A	RINSE AID DISPENSER	1			
S/Nº	Z448618000	CONDUCTO ABRILLANTADOR	POLISH DUCT	1			
10	Z401116000	SOPORTE DOSIFICADOR	DISPENSER SUPPORT	1			
	Q242030000	ARANDELA ABANICO A5 A.304	FAN WASHER A5 A.304	4			
	Q152004000	TORNILLO APLASTADO M5x13 A304	FLAT HEADED BOLT M5x13 A304	2			
11	3704000000	TUBO GOMA NEGRA Ø10,5*5	BLACK RUBBER PIPE Ø10,5*5	1			
	Q881308000	ABRAZADERA 8/14	CLAMP 8/14	2			
12	Z701135000	ELECTROVALV. SIMP. 220V 255.208	SIMP. SOLENOID VALVE 220V 25	1			

MOD.	LAVAVASOS	ZONA	CONJUNTO FUNCIONAL ACLARADO
------	-----------	------	-----------------------------

ITEM	CODIGO	DENOMINACION	TEXTO	LVC-12				
13	Z401111000	SOPORTE ELECTROVALVULA	SOLENOID VLVE SUPPORT	1				
	Q242030000	ARANDELA ABANICO A5 A.304	FAN WASHER A5 A.304	6				
	Q152004000	TORNILLO APLASTADO M5x13 A304	FLAT HEADED BOLT M5x13 A304	4				
	Q152024000	TORNILLO AVELLANADO M4X8 A304	COUNTERSUNK BOLT M4X8 A304	2				
	Q012031000	TORNILLO EXAGONAL M5X10	HEXAGONAL BOLT M5x10	2				
	Q162030000	TUERCA EXAGONAL M5	HEXAGONAL NUT M5	2				
14	Z601114000	MANGUERA ENTRADA AGUA	WATER INTAKE HOSE	1				
15	3676900000	TUBO GOMA NEGRA Ø17*10	BLACK RUBBER PIPE Ø17*10	1				
	Q881302000	ABRAZADERA 12/20	CLAMP 12/20	2				
16	3676900000	TUBO GOMA NEGRA Ø17*10	BLACK RUBBER PIPE Ø17*10	1				
	Q881302000	ABRAZADERA 12/20	CLAMP 12/20	2				
17	Z201106000	RACORD EN Y	Y-CONNECTION	1				
18	Z601157000	TOMA PRESION	PRESSURE INTAKE	1				
19	3676900000	TUBO GOMA NEGRA Ø17*10	BLACK RUBBER PIPE Ø17*10	1				
	Q881302000	ABRAZADERA 12/20	CLAMP 12/20	2				
20	3676900000	TUBO GOMA NEGRA Ø17*10	BLACK RUBBER PIPE Ø17*10	1				
	Q881302000	ABRAZADERA 12/20	CLAMP 12/20	2				

Зип Общепит

vsezip.ru

+7(812)987-08-81

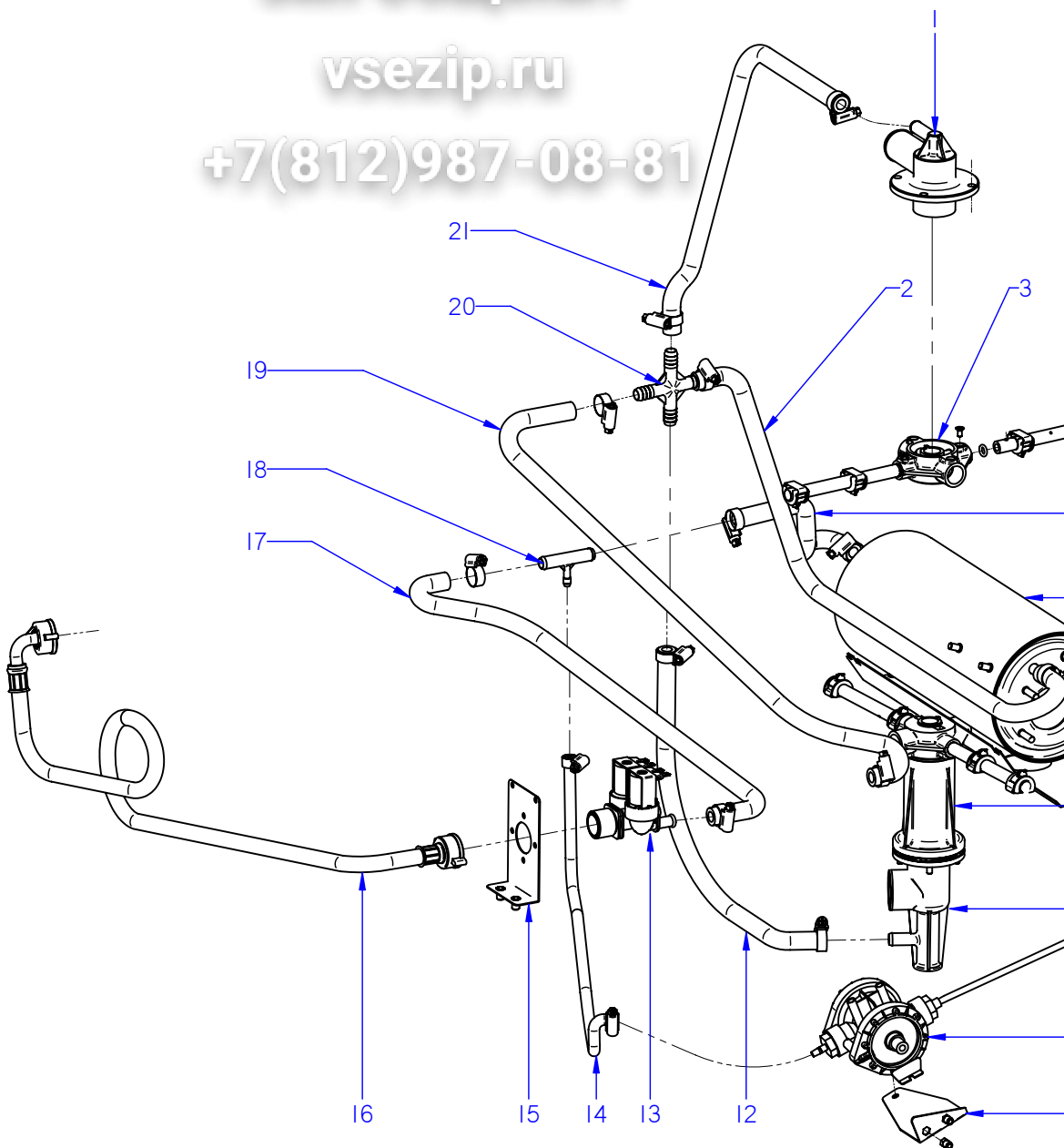

ITEM MARCADO EN COLOR = REPUESTO RECOMENDADO
COLOURED ITEM = RECOMMENDED SPARE PART

N plano	Firma	Fecha	Aparato	Lamina	Fagor Industrial S. Coop.
C-21115	<i>(Signature)</i>	2009-10	LAVAVASOS LVC-15 / 21 / 21B	6	Onete
CONJUNTO FUNCIONAL ACLARADO					



MOD.		LAVAVASOS		ZONA		CONJUNTO FUNCIONAL ACLARADO	
ITEM	CODIGO	DENOMINACION	TEXTO	LVC-15	LVC-21	LVC-21B	
1	Z410703000	SOPORTE DISTRIBUIDOR SUPER.	UPPER DISTRIBUTION SUPPORT	1	1	1	
	Q232040000	ARANDELA A6	WASHER A6	4	4	4	
	Q262040000	ARANDELA GROW. A6 A.304	WASHER GROW. A6 A.304	4	4	4	
	Q162040000	TUERCA EXAGONAL M6	HEXAGONAL NUT M6	4	4	4	
2	3676900000	TUBO GOMA NEGRA Ø17*10	BLACK RUBBER PIPE Ø17*10	1	1	1	
	Q881302000	ABRAZADERA 12/20	CLAMP 12/20	2	2	2	
3	Z410704000	CRUCETA	CROSSPIECE	2	2	2	
	Q152016000	TORNILLO ESPECIAL M.5X0.8	SPECIAL BOLT M.5X0.8	2	2	2	
	Z410705000	CASQUILLO CRUCETA	CROSSPIECE BUSHING	4	4	4	
4	Z461901000	RAMA ACLARADO B	RINSE BRANCH B	2			
4	Z441902000	RAMA ACLARADO B	RINSE BRANCH B		2	2	
S/Nº	Z461902000	RAMA ACLARADO A	RINSE BRANCH A	2			
S/Nº	Z441901000	RAMA ACLARADO A	RINSE BRANCH A		2	2	
	Z201905000	TOBERA ACLARADO	RINSE NOZZLE	8			
	Z211903000	TOBERA ACLARADO	RINSE NOZZLE		10	10	
	Z201906000	ENGANCHE TOB. ACLA.19728	NOZZLE LATCH RINSE.19728	8			
	Q307036000	JUNTA TORICA 5,28X8,84X1,78	O-RING 5.28X8.84X1.78	8			
	Q042021000	TORNILL. AVELLANADO M4X10 A304	COUNTERSUNK BOLT M4X10 A304	4	4	4	
5	3676900000	TUBO GOMA NEGRA Ø17*10	BLACK RUBBER PIPE Ø17*10	1	1	1	
	Q881302000	ABRAZADERA 12/20	CLAMP 12/20	2	2	2	
6	12022893	CALDERIN LAVAVASOS 10-2	GLASSWASHER BOILER 10-2	1	1	1	
7	Z701152000	PESO FILTRO	FILTER WEIGHT	1	1	1	
8	Z410701000	SOPORTE INFERIOR CUADRO	LOWER SUPPORT BRACKET	1	1	1	
9	Z410702000	PASAMUROS CESTO CUADRADO	SQUARE BASKET WALL BUSHING	1	1	1	
	Q232030000	ARANDELA A5	WASHER A5	4	4	4	
	Q262030000	ARANDELA GROW. A5 A.304	WASHER GROW. A5 A.304	4	4	4	
	Q162030000	TUERCA EXAGONAL M5	HEXAGONAL NUT M5	4	4	4	
10	Z211109000	DOSIFICADOR TENSOACTIVO N-6	SURFACE ACT. DISP. N-6	1	1	1	
10	12045206	DOSIFICADOR_ABRILLANTADOR_A	RINSE AID DISPENSER	1	1	1	
S/Nº	Z448618000	CONDUCTO ABRILLANTADOR	POLISH DUCT	1	1	1	

MOD.	LAVAVASOS	ZONA	CONJUNTO FUNCIONAL ACLARADO			
ITEM	CODIGO	DENOMINACION	TEXTO	LVC-15	LVC-21	LVC-21B
11	Z401116000	SOPORTE DOSIFICADOR	DISPENSER SUPPORT	1	1	1
	Q242030000	ARANDELA ABANICO A5 A.304	FAN WASHER A5 A.304	4	4	4
	Q152004000	TORNILLO APLASTADO M5x13 A304	FLAT HEADED BOLT M5x13 A304	2	2	2
12	3676900000	TUBO GOMA NEGRA Ø17*10	BLACK RUBBER PIPE Ø17*10	1	1	1
	Q881302000	ABRAZADERA 12/20	CLAMP 12/20	2	2	2
13	P255001000	ELECTROVALVULA DOBLE	DOUBLE SOLENOID VALVE	1	1	1
14	3704000000	TUBO GOMA NEGRA Ø10,5*5	BLACK RUBBER PIPE Ø10,5*5	1	1	1
	Q881308000	ABRAZADERA 8/14	CLAMP 8/14	2	2	2
15	Z401111000	SOPORTE ELECTROVALVULA	SOLENOID VLVE SUPPORT	1	1	-
	Q242030000	ARANDELA ABANICO A5 A.304	FAN WASHER A5 A.304	2	2	-
	Q152004000	TORNILLO APLASTADO M5x13 A304	FLAT HEADED BOLT M5x13 A304	2	2	-
	Q152024000	TORNILLO AVELLANADO M4X8 A304	COUNTERSUNK BOLT M4X8 A304	2	2	-
16	Z601114000	MANGUERA ENTRADA AGUA	WATER INTAKE HOSE	1	1	1
17	3676900000	TUBO GOMA NEGRA Ø17*10	BLACK RUBBER PIPE Ø17*10	1	1	1
	Q881302000	ABRAZADERA 12/20	CLAMP 12/20	2	2	2
18	Z601157000	TOMA PRESION	PRESSURE INTAKE	1	1	1
19	3676900000	TUBO GOMA NEGRA Ø17*10	BLACK RUBBER PIPE Ø17*10	1	1	1
	Q881302000	ABRAZADERA 12/20	CLAMP 12/20	2	2	2
20	Z401108000	RACORD EN CRUZ	DIAGONAL CONNECTION	1	1	1
21	3676900000	TUBO GOMA NEGRA Ø17*10	BLACK RUBBER PIPE Ø17*10	1	1	1
	Q881302000	ABRAZADERA 12/20	CLAMP 12/20	2	2	2

Зип Общепит
 vsezip.ru
 +7(812)987-08881

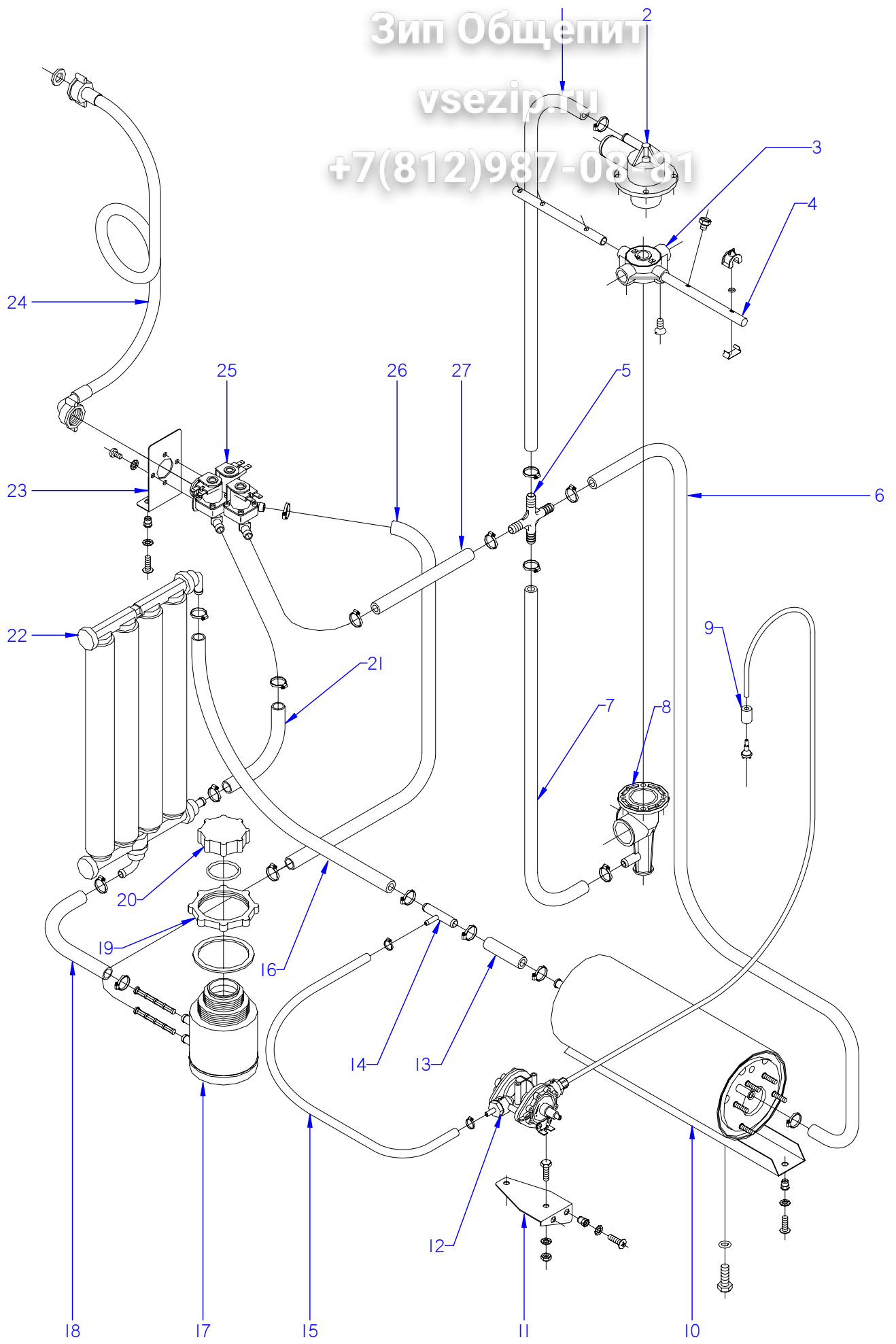

ITEM MARCADO EN COLOR = REPUESTO RECOMENDADO
 COLOURED ITEM = RECOMMENDED SPARE PART

N plano	Firma	Fecha	Aparato	CONJUNTO FUNCIONAL ACLARADO	Lamina	Fagor Industrial S.Coop. FAGOR
C-2116	<i>[Signature]</i>	2009-10	LAVAVASOS LVC-15D / LVC-21D		7	Oñate

MOD.		LAVAVASOS		ZONA		CONJUNTO FUNCIONAL ACLARADO			
ITEM	CODIGO	DENOMINACION	TEXTO	LVC-15D	LVC-21D				
1	3676900000	TUBO GOMA NEGRA Ø17*10	BLACK RUBBER PIPE Ø17*10	1	1				
	Q881302000	ABRAZADERA 12/20	CLAMP 12/20	2	2				
2	Z410703000	SOPORTE DISTRIBUIDOR SUPER.	UPPER DISTRIBUTION SUPPORT	1	1				
	Q232040000	ARANDELA A6	WASHER A6	4	4				
	Q262040000	ARANDELA GROW. A6 A.304	WASHER GROW. A6 A.304	4	4				
	Q162040000	TUERCA EXAGONAL M6	HEXAGONAL NUT M6	4	4				
3	Z410704000	CRUCETA	CROSSPIECE	2	2				
	Q152016000	TORNILLO ESPECIAL M.5X0.8	SPECIAL BOLT M.5X0.8	2	2				
	Z410705000	CASQUILLO CRUCETA	CROSSPIECE BUSHING	4	4				
4	Z461901000	RAMA ACLARADO B	RINSE BRANCH B	2					
4	Z441902000	RAMA ACLARADO B	RINSE BRANCH B		2				
S/Nº	Z461902000	RAMA ACLARADO A	RINSE BRANCH A	2					
S/Nº	Z441901000	RAMA ACLARADO A	RINSE BRANCH A		2				
	Z201905000	TOBERA ACLARADO	RINSE NOZZLE	8					
	Z211903000	TOBERA ACLARADO	RINSE NOZZLE		10				
	Z201906000	ENGANCHE TOB. ACLA.19728	NOZZLE LATCH RINSE.19728	8					
	Q307036000	JUNTA TORICA 5,28X8,84X1,78	O-RING 5.28X8.84X1.78	8					
	Q042021000	TORNILL. AVELLANADO M4X10 A304	COUNTERSUNK BOLT M4X10 A304	4	4				
5	Z401108000	RACORD EN CRUZ	DIAGONAL CONNECTION	1	1				
6	3676900000	TUBO GOMA NEGRA Ø17*10	BLACK RUBBER PIPE Ø17*10	1	1				
	Q881302000	ABRAZADERA 12/20	CLAMP 12/20	2	2				
7	3676900000	TUBO GOMA NEGRA Ø17*10	BLACK RUBBER PIPE Ø17*10	1	1				
	Q881302000	ABRAZADERA 12/20	CLAMP 12/20	2	2				
8	Z410702000	PASAMUROS CESTO CUADRADO	SQUARE BASKET WALL BUSHING	1	1				
	Q232030000	ARANDELA A5	WASHER A5	4	4				
	Q262030000	ARANDELA GROW. A5 A.304	WASHER GROW. A5 A.304	4	4				
	Q162030000	TUERCA EXAGONAL M5	HEXAGONAL NUT M5	4	4				
9	Z701152000	PESO FILTRO	FILTER WEIGHT	1	1				
10	12022893	CALDERIN LAVAVASOS 10-2	GLASSWASHER BOILER 10-2	1	1				

MOD.	LAVAVASOS	ZONA	CONJUNTO FUNCIONAL ACLARADO					
ITEM	CODIGO	DENOMINACION	TEXTO	LVC-15D	LVC-21D			
11	Z401116000	SOPORTE DOSIFICADOR	DISPENSER SUPPORT	1	1			
	Q242030000	ARANDELA ABANICO A5 A.304	FAN WASHER A5 A.304	4	4			
	Q152004000	TORNILLO APLASTADO M5x13 A304	FLAT HEADED BOLT M5x13 A304	2	2			
10	Z211109000	DOSIFICADOR TENSOACTIVO N-6	SURFACE ACT. DISP. N-6	1	1			
S/Nº	Z448618000	CONDUCTO ABRILLANTADOR	POLISH DUCT	1	1			
13	3676900000	TUBO GOMA NEGRA Ø17*10	BLACK RUBBER PIPE Ø17*10	1	1			
	Q881302000	ABRAZADERA 12/20	CLAMP 12/20	2	2			
14	Z601157000	TOMA PRESION	PRESSURE INTAKE	1	1			
15	3704000000	TUBO GOMA NEGRA Ø10,5*5	BLACK RUBBER PIPE Ø10,5*5	1	1			
	Q881308000	ABRAZADERA 8/14	CLAMP 8/14	2	2			
16	3676900000	TUBO GOMA NEGRA Ø17*10	BLACK RUBBER PIPE Ø17*10	1	1			
	Q881302000	ABRAZADERA 12/20	CLAMP 12/20	2	2			
17	Z471102000	DEPOSITO SOLDADO	WELDED TANK	1	1			
	Z471105000	FILTRO (BITRON 06281.01)	FILTER (BITRON 06281.01)	2	2			
18	3676900000	TUBO GOMA NEGRA Ø17*10	BLACK RUBBER PIPE Ø17*10	1	1			
	Q881302000	ABRAZADERA 12/20	CLAMP 12/20	2	2			
19	Z471106000	TUERCA (BITRON 27414.00)	NUT (BITRON 27414.00)	1	1			
	Z471107000	JUNTA TUERCA (BITRON 15702.01)	NUT SEAL (BITRON 15702.01)	1	1			
20	Z471108000	TAPON (BITRON 27415.00)	PLUG (BITRON 27415.00)	1	1			
	Z471109000	JUNTA TAPON (BITRON 06485.02)	PLUG SEAL (BITRON 06485.02)	1	1			
21	3676900000	TUBO GOMA NEGRA Ø17*10	BLACK RUBBER PIPE Ø17*10	1	1			
	Q881302000	ABRAZADERA 12/20	CLAMP 12/20	2	2			
22	Z471101000	DESCALCIFICADOR 4 COLUMNAS	WATER SOFTENER 4 COLUMN	1	1			
	Z471111000	SOPOR. SUPERIOR DESCALCIFICA	UPPER W-SOFT. SUPPORT.	1	—			
	Z491101000	SOPOR. SUPERIOR DESCALCIFICA	UPPER W-SOFT. SUPPORT.	—	1			
	Z471112000	SOPOR. INFERIOR DESCALCIFICAD	LOWER W-SOFT. SUPPORT.	1	1			
23	Z401111000	SOPORTE ELECTROVALVULA	SOLENOID VLVE SUPPORT	1	1			
	Q242030000	ARANDELA ABANICO A5 A.304	FAN WASHER A5 A.304	2	2			
	Q152004000	TORNILLO APLASTADO M5x13 A304	FLAT HEADED BOLT M5x13 A304	2	2			
	Q152024000	TORNILLO AVELLANADO M4X8 A304	COUNTERSUNK BOLT M4X8 A304	2	2			
24	Z602121000	MANGUERA ENTRADA AGUA	WATER INTAKE HOSE	1	1			

MOD.		LAVAVASOS		ZONA		CONJUNTO FUNCIONAL ACLARADO			
ITEM	CODIGO	DENOMINACION	TEXTO	LVC-15D	LVC-21D				
25	Z611124000	(12Z6111240) ELECTROVAL.TRIPL	(12Z6111240) SOLENOID VALVE.	1	1				
26	3676900000	TUBO GOMA NEGRA Ø17*10	BLACK RUBBER PIPE Ø17*10	1	1				
	Q881302000	ABRAZADERA 12/20	CLAMP 12/20	2	2				
27	3676900000	TUBO GOMA NEGRA Ø17*10	BLACK RUBBER PIPE Ø17*10	1	1				
	Q881302000	ABRAZADERA 12/20	CLAMP 12/20	2	2				

Зип Общепит

vsezip.ru

+7(812)987-08-81

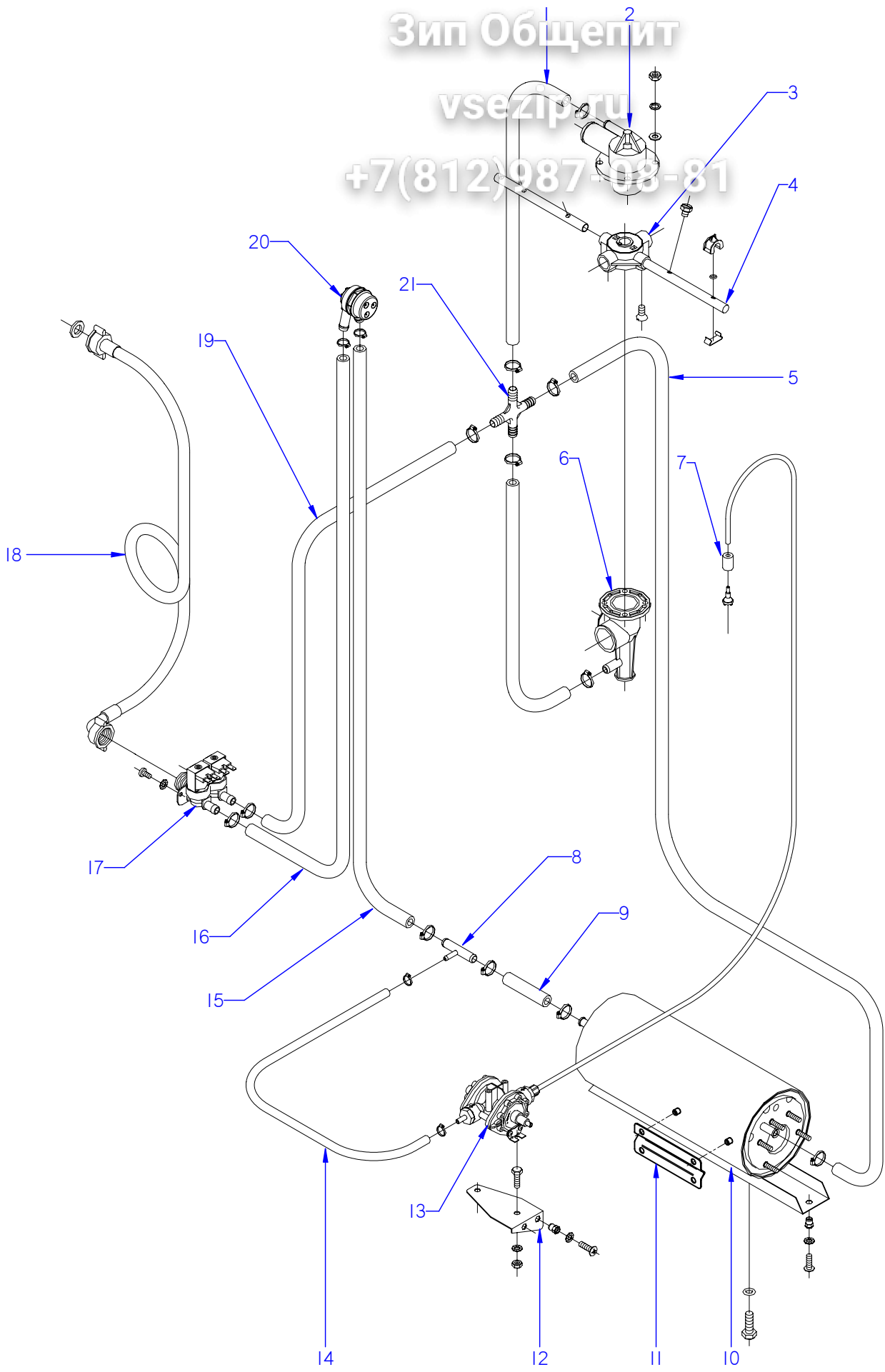

ITEM MARCADO EN COLOR = REPUESTO RECOMENDADO
COLOURED ITEM = RECOMMENDED SPARE PART

N plano	Firma	Fecha	Aparato	CONJUNTO FUNCIONAL ACLARADO	Lamina	Fagor Industrial S.Coop. FAGOR
C-2117	<i>[Signature]</i>	2009-10	LAVAVASOS LVC-21C / 21W		8	Oñate

MOD.		LAVAVASOS		ZONA		CONJUNTO FUNCIONAL ACLARADO			
ITEM	CODIGO	DENOMINACION	TEXTO	LVC-21C	LVC-21W				
1	3676900000	TUBO GOMA NEGRA Ø17*10	BLACK RUBBER PIPE Ø17*10	1	1				
	Q881302000	ABRAZADERA 12/20	CLAMP 12/20	2	2				
	Z410703000	SOPORTE DISTRIBUIDOR SUPER.	UPPER DISTRIBUTION SUPPORT	1	1				
2	Q232040000	ARANDELA A6	WASHER A6	4	4				
	Q262040000	ARANDELA GROW. A6 A.304	WASHER GROW. A6 A.304	4	4				
	Q162040000	TUERCA EXAGONAL M6	HEXAGONAL NUT M6	4	4				
	Z410704000	CRUCETA	CROSSPIECE	2	2				
3	Q152016000	TORNILLO ESPECIAL M.5X0.8	SPECIAL BOLT M.5X0.8	2	2				
	Z410705000	CASQUILLO CRUCETA	CROSSPIECE BUSHING	4	4				
	Z441902000	RAMA ACLARADO B	RINSE BRANCH B	2	2				
S/Nº	Z441901000	RAMA ACLARADO A	RINSE BRANCH A	2	2				
	Z211903000	TOBERA ACLARADO	RINSE NOZZLE	10	10				
5	Q042021000	TORNILL. AVELLANADO M4X10 A304	COUNTERSUNK BOLT M4X10 A304	4	4				
	3676900000	TUBO GOMA NEGRA Ø17*10	BLACK RUBBER PIPE Ø17*10	1	1				
	Q881302000	ABRAZADERA 12/20	CLAMP 12/20	2	2				
	Z410702000	PASAMUROS CESTO CUADRADO	SQUARE BASKET WALL BUSHING	1	1				
	Q232030000	ARANDELA A5	WASHER A5	4	4				
6	Q262030000	ARANDELA GROW. A5 A.304	WASHER GROW. A5 A.304	4	4				
	Q162030000	TUERCA EXAGONAL M5	HEXAGONAL NUT M5	4	4				
	Z701152000	PESO FILTRO	FILTER WEIGHT	1	1				
	Z601157000	TOMA PRESION	PRESSURE INTAKE	1	1				
9	3676900000	TUBO GOMA NEGRA Ø17*10	BLACK RUBBER PIPE Ø17*10	1	1				
	Q881302000	ABRAZADERA 12/20	CLAMP 12/20	2	2				
10	12022893	CALDERIN LAVAVASOS 10-2	GLASSWASHER BOILER 10-2	1	—				
	12022893	CALDERIN LAVAVASOS 10-2	GLASSWASHER BOILER 10-2	—	1				
	12046994	CALDERIN COMPLETO LVS. W	GLASSWASHER BOILER 10-2	—	1				
11	Z748008000	SOPORTE BULBO TERMOSTATO	THERMOSTAT BULB SUPPORT	1	1				
	Q152018000	PERNO SOLDADO M6X10	WELDED BOLT M6X10	2	2				
	Q162040000	TUERCA EXAGONAL M6	HEXAGONAL NUT M6	2	2				
	Q232040000	ARANDELA A6	WASHER A6	2	2				
	Q262040000	ARANDELA GROW. A6 A.304	WASHER GROW. A6 A.304	2	2				

MOD.	LAVAVASOS	ZONA	CONJUNTO FUNCIONAL ACLARADO
------	-----------	------	-----------------------------

ITEM	CODIGO	DENOMINACION	TEXTO	LVC-21C	LVC-21W			
12	Z401116000	SOPORTE DOSIFICADOR	DISPENSER SUPPORT	1	1			
	Q242030000	ARANDELA ABANICO A5 A.304	FAN WASHER A5 A.304	4	4			
	Q152004000	TORNILLO APLASTADO M5x13 A304	FLAT HEADED BOLT M5x13 A304	2	2			
13	Z211109000	DOSIFICADOR TENSOACTIVO N-6	SURFACE ACT. DISP. N-6	1	1			
13	12045206	DOSIFICADOR ABRILLANTADOR AC	RINSE AID DISPENSER	1	1			
S/Nº	Z448618000	CONDUCTO ABRILLANTADOR	POLISH DUCT	1	1			
14	3704000000	TUBO GOMA NEGRA Ø10,5*5	BLACK RUBBER PIPE Ø10,5*5	1	1			
	Q881308000	ABRAZADERA 8/14	CLAMP 8/14	2	2			
15	3676900000	TUBO GOMA NEGRA Ø17*10	BLACK RUBBER PIPE Ø17*10	1	1			
	Q881302000	ABRAZADERA 12/20	CLAMP 12/20	2	2			
16	3676900000	TUBO GOMA NEGRA Ø17*10	BLACK RUBBER PIPE Ø17*10	1	1			
	Q881302000	ABRAZADERA 12/20	CLAMP 12/20	2	2			
17	P255001000	ELECTROVALVULA DOBLE	DOUBLE SOLENOID VALVE	1	1			
18	Z601114000	MANGUERA ENTRADA AGUA	WATER INTAKE HOSE	1	1			
19	3676900000	TUBO GOMA NEGRA Ø17*10	BLACK RUBBER PIPE Ø17*10	1	1			
	Q881302000	ABRAZADERA 12/20	CLAMP 12/20	2	2			
20	Z231106000	VALVULA ANTIRRETORNO	NON-RETURN VALVE	1	1			
	Q881302000	ABRAZADERA 12/20	CLAMP 12/20	2	2			
21	Z401108000	RACORD EN CRUZ	DIAGONAL CONNECTION	1	1			

Зип Общепит

vsezip.ru

+7(812)987-08-81

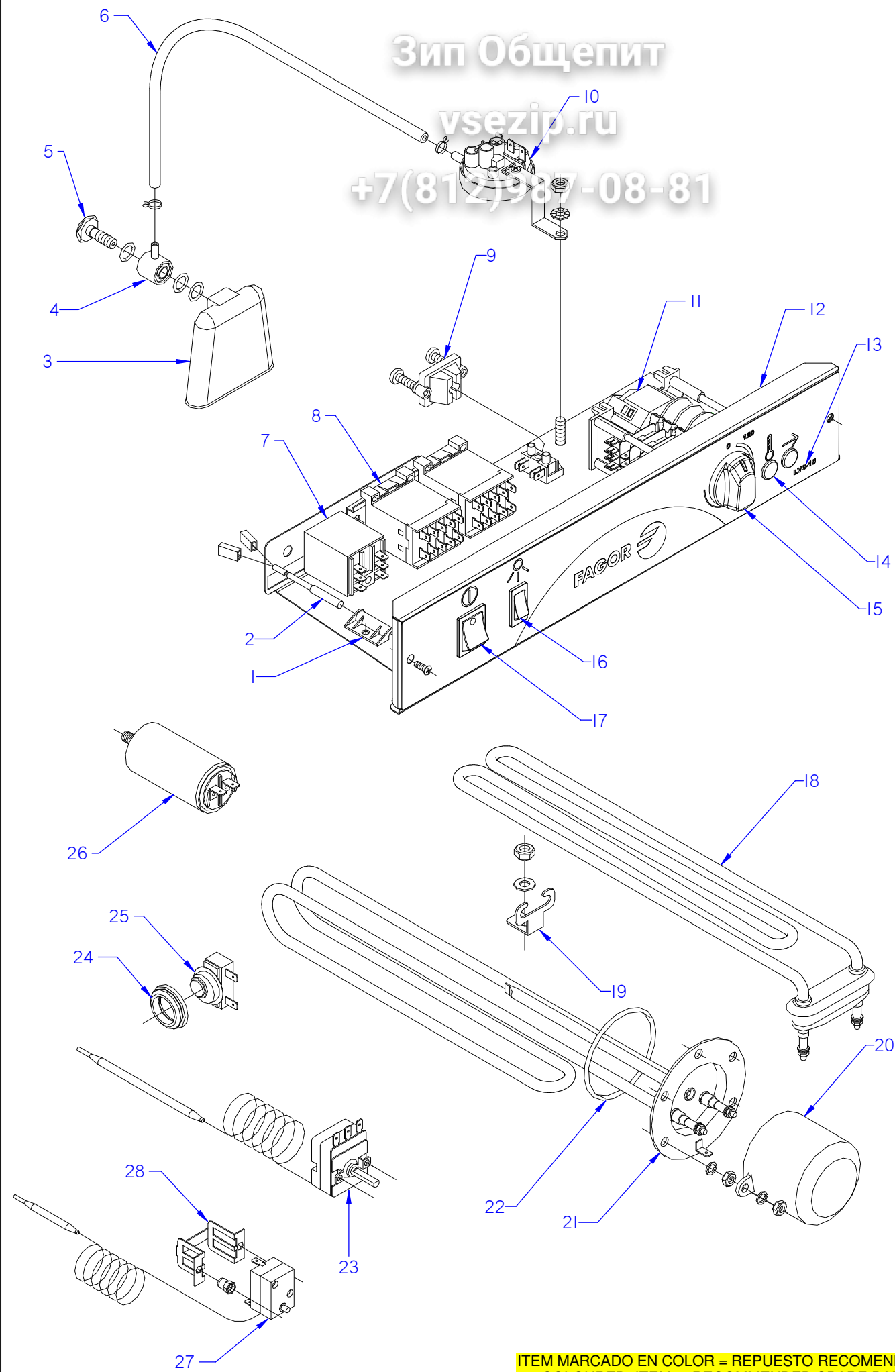

ITEM MARCADO EN COLOR = REPUESTO RECOMENDADO
COLOURED ITEM = RECOMMENDED SPARE PART

N plano	Firma	Fecha	Aparato	CONJUNTO FUNCIONAL ELECTRICO	Lamina	Fagor Industrial S.Coop. FAGOR
C-2118	[Signature]	2009-10	LAVAVASOS LVC-12 / 15 / 21		9	Oñate

MOD.	LAVAVASOS	ZONA	CONJUNTO FUNCIONAL ELECTRICO
-------------	------------------	-------------	-------------------------------------

ITEM	CODIGO	DENOMINACION	TEXTO	LVC-12	LVC-15	LVC-21		
1	Z203010000	AMARRE INTERRUPT. MAGNETICO	MAGNETIC SWITCH FASTENER	1	—	—		
1	Z203010000	AMARRE INTERRUPT. MAGNETICO	MAGNETIC SWITCH FASTENER	—	1	1		
2	Z203009000	INTERRUPTOR MAGNETICO	MAGNETIC SWITCH	1	—	—		
2	Z203009000	INTERRUPTOR MAGNETICO	MAGNETIC SWITCH	—	1	1		
3	Z203011000	CAMARA PRESOSTATO	PRESSURE SWITCH	1	1	1		
4	Z203012000	EMPALME PRESOSTATO	PRESSURE SWITCH CONNEX	1	1	1		
5	Z203013000	TORNILLO PRESOSTATO	PRESSURE SWITCH BOLT	1	1	1		
	Q307003000	JUNTA TORICA 16.01X10.77X2.62	O-RING 16.01X10.77X2.62	3	3	3		
6	3702400000	TUBO GOMA NEGRO D 8*4	BLACK RUBBER PIPE Ø 8*4	1	1	1		
	P102154000	BRIDA ELASTICA TUBO	ELASTIC PIPE FLANGE	2	2	2		
7	Z203062000	RELE 230V. 16A 50-60 HZ	RELAY 230V. 16A 50-60 HZ	—	1	1		
7	Z203062000	RELE 230V. 16A 50-60 HZ	RELAY 230V. 16A 50-60 HZ	2	2	2		
8	12024011	CONTACTOR 230 V. 50-60 HZ	CONTACTOR 230 V. 50-60 HZ	1	1	1		
8	12024011	CONTACTOR 230 V. 50-60 HZ	CONTACTOR 230 V. 50-60 HZ	2	2	2		
8	Z203050000	CONTACT. SIRIUS 3R 230 V.50-60 HZ	CONTACT. SIRIUS 3R 230 V.50/60	—	1	1		
9	Z203020000	RETENEDOR DE CABLE	CABLE HOLDER	1	1	1		
	Z603025000	REGLETA DE CONEXIONES	CONNECTION STRIP	1	1	1		
10	Z403021000	PRESOSTATO SIMPLE	SIMPLE PRESSURE SWITCH	1	1	1		
	Z602923000	SOPORTE PRESOSTATO	PRESSURE SWITCH SUPPORT	1	1	1		
	Q082032000	TORNILLO ALOMADO BZ-3,5X9,5	CURVED SCREW BZ-3.5x9.5	1	1	1		
	Q152004000	TORNILLO APLASTADO M5x13 A304	FLAT HEADED BOLT M5x13 A304	1	1	1		
	Q242030000	ARANDELA ABANICO A5 A.304	FAN WASHER A5 A.304	1	1	1		
	Q162030000	TUERCA EXAGONAL M5	HEXAGONAL NUT M5	1	1	1		
11	Z403002000	PROGRAMADOR CICLO	CYCLE PROGRAMMER	1	1	1		
11	Z403044000	PROGRAMADOR CICLO (60 HZ.)	CYCLE PROGRAMMER (60 HZ.)	—	—	1		
	Z203007000	CASQUILLO	BUSHING	2	2	2		
	Q041324000	TORN. AVELLANADO M4X25 H.ZINC.	HEXAGONAL COUNTERSUNK M4	2	2	2		
12	Z462905000	FRENTE COMPLETO 12-15	COMPLETE FRONT 12-15	1	1	—		
12	12046878	FRENTE COMPLETO FAGOR 12	COMPLETE FRONT FAGOR 12	1	1	—		
12	Z442905000	FRENTE COMPLETO 21	COMPLETE FRONT 21	—	—	1		
12	12046877	FRENTE COMPLETO FAGOR 21	COMPLETE FRONT FAGOR 21	—	—	1		

MOD.		LAVAVASOS		ZONA	CONJUNTO FUNCIONAL ELECTRICO		
ITEM	CODIGO	DENOMINACION	TEXTO	LVC-12	LVC-15	LVC-21	
13	Z462904000	EMBELLECEDOR ADHES. LVC-12	ADHES. TRIM LVC-12	1	—	—	
13	Z412902000	EMBELLECEDOR ADHES. LVC-15	ADHES. TRIM LVC-15	—	1	—	
13	Z442904000	EMBELLECEDOR ADHES. LVC-21	ADHES. TRIM LVC-21	—	—	1	
14	12024254	PILOTO AMBAR 41227000A4	AMBER PILOT 41227000A4	1	2	2	
15	Z203069000	BOTON DE MANDO	CONTROL BUTTON	1	1	1	
16	Z203070000	PULSADOR NEGRO	BLACK BUTTON	—	1	1	
17	Z203071000	INTERRUPTOR NEGRO	BLACK SWITCH	1	1	1	
18	Z733601000	RESISTENCIA TANQUE	TANK RESISTOR	1	—	—	
18	R223005000	RESISTENCIA TANQUE	TANK RESISTOR	—	1	1	
19	Z603602000	SOPORTE RESISTENCIA TANQUE	TANK RESISTOR SUPPORT	1	1	1	
	Q232040000	ARANDELA A6	WASHER A6	1	1	1	
	Q162040000	TUERCA EXAGONAL M6	HEXAGONAL NUT M6	1	1	1	
20	Z401713000	CAPERUZA RESISTENC. CALDERIN	BOILER RESIST. CAP	1	1	1	
	Q163140000	TUERCA EXAGONAL M6 LATON	HEXAGONAL NUT M6 BRASS	2	2	2	
	Q242030000	ARANDELA ABANICO A5 A.304	FAN WASHER A5 A.304	2	2	2	
	Q152004000	TORNILLO APLASTADO M5x13 A304	FLAT HEADED BOLT M5x13 A304	2	2	2	
21	Z401738000	RESISTENCIA CALDERIN 2400W	BOILER RESISTOR 2400W	1	1	—	
21	Z421712000	RESISTENCIA CALDERIN 2800W	BOILER RESISTOR 2800W	—	—	1	
	Q221301000	TUERCA EXAG.AUTOBLOCANTE M6	SELF-LOCK HEX NUT M6	2	2	2	
	Q163140000	TUERCA EXAGONAL M6 LATON	HEXAGONAL NUT M6 BRASS	5	5	5	
	Q262040000	ARANDELA GROW. A6 A.304	WASHER GROW. A6 A.304	5	5	5	
22	Q307053000	JUNTA TORICA 43.82X54.48X5.35	"O" RING 43.82X54.48X5.35	1	1	1	
23	Z393005000	TERMOSTATO CALDERIN	WASH DRUM THERMOSTAT	1	1	1	
	Q152024000	TORNILLO AVELLANADO M4X8 A304	COUNTERSUNK BOLT M4X8 A304	2	2	2	
24	N503017000	SOPORTE TERMOSTATO 1001713	THERMOSTAT SUPPORT 1001713	1	1	1	
25	Z718405000	TERMOSTATO DOBLE	DOUBLE THERMOSTAT	1	1	1	
26	V817100000	CONDENSADOR 6 M.F.	CONDENSER 6 M.F.	1	1	1	
27	12023830	LIMITADOR TECASA P.	TECASA P. LIMITER	1	1	1	
28	12022151	AMARRE LIMITADOR TECASA	LIMITER FASTENING	1	1	1	

Зип Общепит

vsezip.ru

+7(812)987-08-81

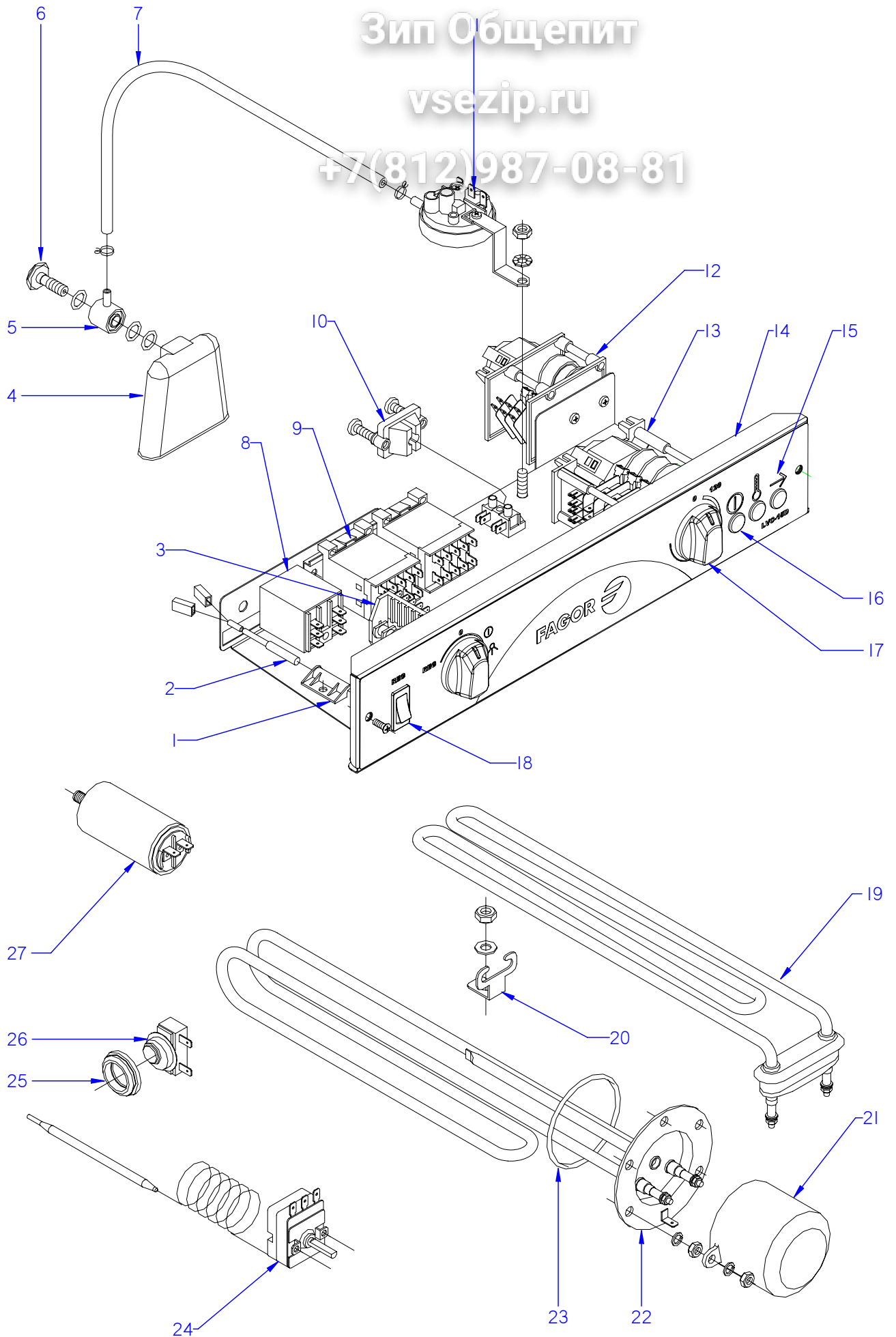

ITEM MARCADO EN COLOR = REPUESTO RECOMENDADO
COLOURED ITEM = RECOMMENDED SPARE PART

N plano	Firma	Fecha	Aparato	CONJUNTO FUNCIONAL ELECTRICO	Lamina	Fagor Industrial S.Coop. FAGOR
C-2119	<i>[Signature]</i>	2009-10	LAVAVASOS LVC-15D / LVC-21D		10	Oñate

MOD.	LAVAVASOS	ZONA	CONJUNTO FUNCIONAL ELECTRICO
------	-----------	------	------------------------------

ITEM	CODIGO	DENOMINACION	TEXTO	LVC-15D	LVC-21D			
1	Z203010000	AMARRE INTERRUPT. MAGNETICO	MAGNETIC SWITCH FASTENER	1	1			
2	Z203009000	INTERRUPTOR MAGNETICO	MAGNETIC SWITCH	1	1			
3	Z433001000	CONMUTADOR DE FUNCIONES	FUNCTIONS SWITCH	1	1			
	Z203007000	CASQUILLO	BUSHING	2	2			
	Q041324000	TORN. AVELLANADO M4X25 H.ZINC	HEXAGONAL COUNTERSUNK M4	2	2			
4	Z203011000	CAMARA PRESOSTATO	PRESSURE SWITCH	1	1			
5	Z203012000	EMPALME PRESOSTATO	PRESSURE SWITCH CONNEX	1	1			
6	Z203013000	TORNILLO PRESOSTATO	PRESSURE SWITCH BOLT	1	1			
	Q307003000	JUNTA TORICA 16.01X10.77X2.62	O-RING 16.01X10.77X2.62	3	3			
7	3702400000	TUBO GOMA NEGRO D 8*4	BLACK RUBBER PIPE Ø 8*4	1	1			
	P102154000	BRIDA ELASTICA TUBO	ELASTIC PIPE FLANGE	2	2			
8	Z203062000	RELE 230V. 16A 50-60 HZ	RELAY 230V. 16A 50-60 HZ	1	1			
9	Z213007000	CONTACTOR 230 V. 50-60 HZ	CONTACTOR 230 V. 50-60 HZ	2	2			
10	Z203020000	RETENEDOR DE CABLE	CABLE HOLDER	1	1			
	Z603025000	REGLETA DE CONEXIONES	CONNECTION STRIP	1	1			
	Q032021000	TORNILLO ALOMADO M4X10	CURVED SCREW M4X10	1	1			
	Q162020000	TUERCA EXAGONAL M4	HEXAGONAL NUT M4	1	1			
11	Z403021000	PRESOSTATO SIMPLE	SIMPLE PRESSURE SWITCH	1	1			
	Z602923000	SOPORTE PRESOSTATO	PRESSURE SWITCH SUPPORT	1	1			
	Q082032000	TORNILLO ALOMADO BZ-3,5X9,5	CURVED SCREW BZ-3.5x9.5	1	1			
	Q152004000	TORNILLO APLASTADO M5x13 A304	FLAT HEADED BOLT M5x13 A304	1	1			
	Q242030000	ARANDELA ABANICO A5 A.304	FAN WASHER A5 A.304	1	1			
	Q162030000	TUERCA EXAGONAL M5	HEXAGONAL NUT M5	1	1			
12	Z613003000	PROGRAMADOR REGENERACION	REGENERATION PROGRAMMER	1	1			
	Q032021000	TORNILLO ALOMADO M4x10	CURVED SCREW M4X10	2	2			
13	Z403002000	PROGRAMADOR CICLO	CYCLE PROGRAMMER	1	1			
	Z203007000	CASQUILLO	BUSHING	2	2			
	Q041324000	TORN. AVELLANADO M4X25 H.ZINC	HEXAGONAL COUNTERSUNK M4	2	2			
14	Z462905000	FRENTE COMPLETO 12-15	COMPLETE FRONT 12-15	1	-			
14	Z442905000	FRENTE COMPLETO 21	COMPLETE FRONT 21	-	1			
	Q152004000	TORNILLO APLASTADO M5x13 A304	FLAT HEADED BOLT M5x13 A304	2	2			

MOD.		LAVAVASOS		ZONA	CONJUNTO FUNCIONAL ELECTRICO			
ITEM	CODIGO	DENOMINACION	TEXTO	LVC-15D	LVC-21D			
15	Z482904000	EMBELLECEDOR ADHES. LVC-15D	ADHES. TRIM LVC-15D	1	=			
15	Z502902000	EMBELLECEDOR ADHES. LVC-21D	ADHES. TRIM LVC-21D	=	1			
16	R693056000	PILOTO AMBAR 41227000A4	AMBER PILOT 41227000A4	3	3			
17	Z203069000	BOTON DE MANDO	CONTROL BUTTON	2	2			
18	Z203070000	PULSADOR NEGRO	BLACK BUTTON	1	1			
19	R223005000	RESISTENCIA TANQUE	TANK RESISTOR	1	1			
20	Z603602000	SOPORTE RESISTENCIATANQUE	TANK RESISTOR SUPPORT	1	1			
	Q232040000	ARANDELA A6	WASHER A6	1	1			
	Q162040000	TUERCA EXAGONAL M6	HEXAGONAL NUT M6	1	1			
21	Z401713000	CAPERUZA RESISTENC. CALDERIN	BOILER RESIST. CAP	1	1			
	Q163140000	TUERCA EXAGONAL M6 LATON	HEXAGONAL NUT M6 BRASS	2	2			
	Q242030000	ARANDELA ABANICO A5 A.304	FAN WASHER A5 A.304	2	2			
	Q152004000	TORNILLO APLASTADO M5x13 A304	FLAT HEADED BOLT M5x13 A304	2	2			
22	Z401738000	RESISTENCIA CALDERIN 2400W	BOILER RESISTOR 2400W	1	=			
22	Z421712000	RESISTENCIA CALDERININ 2800W	BOILER RESISTOR 2800W	=	1			
	Q221301000	TUERCA EXAG.AUTOBLOCANTE M6	SELF-LOCK HEX NUT M6	2	2			
	Q163140000	TUERCA EXAGONAL M6 LATON	HEXAGONAL NUT M6 BRASS	5	5			
	Q262040000	ARANDELA GROW. A6 A.304	WASHER GROW. A6 A.304	5	5			
23	Q307053000	JUNTA TORICA 43.82X54.48X5.35	"O" RING 43.82X54.48X5.35	1	1			
24	Z393005000	TERMOSTATO CALDERIN	WASH DRUM THERMOSTAT	1	1			
	Q152024000	TORNILLO AVELLANADO M4X8 A304	COUNTERSUNK BOLT M4X8 A304	2	2			
25	N503017000	SOPORTE TERMOSTATO 1001713	THERMOSTAT SUPPORT 100171	1	1			
26	Z718405000	TERMOSTATO DOBLE	DOUBLE THERMOSTAT	1	1			
27	V817100000	CONDENSADOR 6 M.F.	CONDENSER 6 M.F.	1	1			

Зип Общепит

vsezip.ru

+7(812)987-08-81

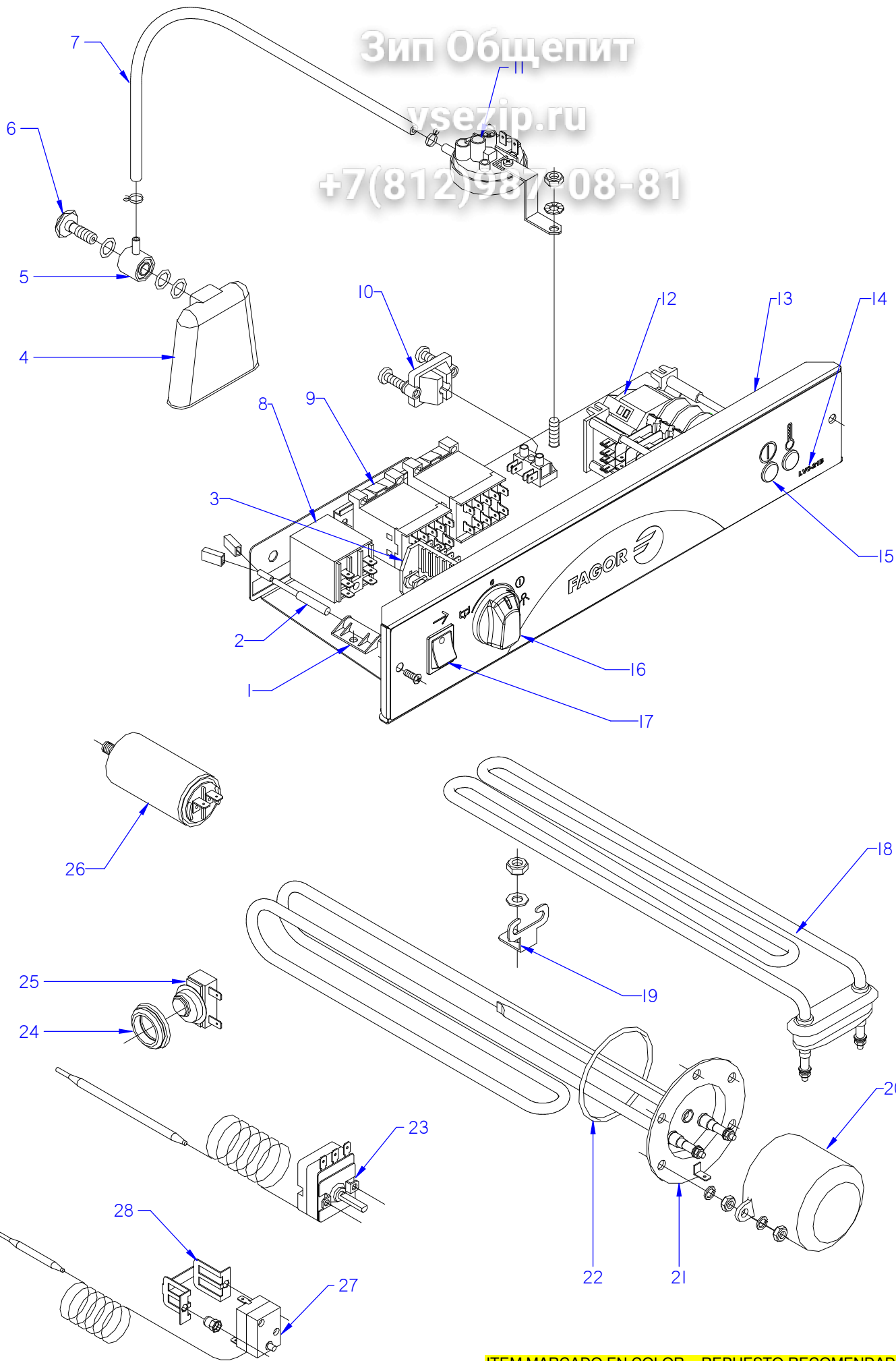

ITEM MARCADO EN COLOR = REPUESTO RECOMENDADO
COLOURED ITEM = RECOMMENDED SPARE PART

N plano	Firma	Fecha	Aparato	CONJUNTO FUNCIONAL ELECTRICO	Lamina	Fagor Industrial S.Coop. FAGOR
C-2120	<i>[Signature]</i>	2009-10	LAVAVASOS LVC-21B		11	Oñate

MOD.	LAVAVASOS	ZONA	CONJUNTO FUNCIONAL ELECTRICO
-------------	------------------	-------------	-------------------------------------

ITEM	CODIGO	DENOMINACION	TEXTO	LVC-21B			
1	Z203010000	AMARRE INTERRUPT. MAGNETICO	MAGNETIC SWITCH FASTENER	1			
2	Z203009000	INTERRUPTOR MAGNETICO	MAGNETIC SWITCH	1			
3	Z433001000	CONMUTADOR DE FUNCIONES	FUNCTIONS SWITCH	1			
4	Z203011000	CAMARA PRESOSTATO	PRESSURE SWITCH	1			
5	Z203012000	EMPALME PRESOSTATO	PRESSURE SWITCH CONNEX	1			
6	Z203013000	TORNILLO PRESOSTATO	PRESSURE SWITCH BOLT	1			
	Q307003000	JUNTA TORICA 16.01X10.77X2.62	O-RING 16.01X10.77X2.62	3			
7	3702400000	TUBO GOMA NEGRO D 8*4	BLACK RUBBER PIPE Ø 8*4	1			
	P102154000	BRIDA ELASTICA TUBO	ELASTIC PIPE FLANGE	2			
8	Z203062000	RELE 230V. 16A 50-60 HZ	RELAY 230V. 16A 50-60 HZ	1			
8	Z203062000	RELE 230V. 16A 50-60 HZ	RELAY 230V. 16A 50-60 HZ	2			
9	Z203050000	CONTACT. SIRIUS 3R 230 V.50-60 HZ	CONTACT. SIRIUS 3R 230 V.50/60	1			
9	12024011	CONTACTOR 230 V. 50-60 HZ	CONTACTOR 230 V. 50-60 HZ	1			
9	12024011	CONTACTOR 230 V. 50-60 HZ	CONTACTOR 230 V. 50-60 HZ	2			
10	Z203020000	RETENEDOR DE CABLE	CABLE HOLDER	1			
	Z603025000	REGLETA DE CONEXIONES	CONNECTION STRIP	1			
	Q032021000	TORNILLO ALOMADO M4X10	CURVED SCREW M4X10	1			
	Q162020000	TUERCA EXAGONAL M4	HEXAGONAL NUT M4	1			
11	Z433011000	PRESOSTATO DOBLE	DOUBLE PRESSURE SWITCH	1			
	Z602923000	SOPORTE PRESOSTATO	PRESSURE SWITCH SUPPORT	1			
	Q082032000	TORNILLO ALOMADO BZ-3,5X9,5	CURVED SCREW BZ-3.5x9.5	1			
	Q152004000	TORNILLO APLASTADO M5x13 A304	FLAT HEADED BOLT M5x13 A304	1			
	Q242030000	ARANDELA ABANICO A5 A.304	FAN WASHER A5 A.304	1			
	Q162030000	TUERCA EXAGONAL M5	HEXAGONAL NUT M5	1			
12	Z433002000	PROGRAMADOR CICLO 50Hz	CYCLE PROGRAMMER 50Hz	1			
12	Z448302000	PROGRAMADOR CICLO 2' 60Hz	CYCLE PROGRAMMER 2' 60Hz	1			
	Z203007000	CASQUILLO	BUSHING	2			
	Q041324000	TORN. AVELLANADO M4X25 H.ZINC	HEXAGONAL COUNTERSUNK M4	2			
13	Z442905000	FRENTE COMPLETO 21	COMPLETE FRONT 21	1			
13	12046877	FRENTE COMPLETO FAGOR 21	COMPLETE FRONT FAGOR 21	1			
	Q152004000	TORNILLO APLASTADO M5x13 A304	FLAT HEADED BOLT M5x13 A304	2			

MOD.		LAVAVASOS		ZONA		CONJUNTO FUNCIONAL ELECTRICO	
ITEM	CODIGO	DENOMINACION	TEXTO	LVC-21B			
14	Z452905000	EMBELLECEDOR ADHES. LVC-21B	ADHES. TRIM LVC-21B	1			
15	R693056000	PILOTO AMBAR 41227000A4	AMBER PILOT 41227000A4	2			
16	Z203069000	BOTON DE MANDO	CONTROL BUTTON	1			
17	Z203080000	PULSADOR MARCHA NEGRO	BLACK RUN BUTTON	1			
18	R223005000	RESISTENCIA TANQUE	TANK RESISTOR	1			
19	Z603602000	SOPORTE RESISTENCIATANQUE	TANK RESISTOR SUPPORT	1			
	Q232040000	ARANDELA A6	WASHER A6	1			
	Q162040000	TUERCA EXAGONAL M6	HEXAGONAL NUT M6	1			
20	Z401713000	CAPERUZA RESISTENC. CALDERIN	BOILER RESIST. CAP	1			
	Q163140000	TUERCA EXAGONAL M6 LATON	HEXAGONAL NUT M6 BRASS	2			
	Q242030000	ARANDELA ABANICO A5 A.304	FAN WASHER A5 A.304	2			
	Q152004000	TORNILLO APLASTADO M5x13 A304	FLAT HEADED BOLT M5x13 A304	2			
21	Z421712000	RESISTENCIACALDERIN 2800W	BOILER RESISTOR 2800W	1			
	Q221301000	TUERCA EXAG.AUTOBLOCANTE M6	SELF-LOCK HEX NUT M6	2			
	Q163140000	TUERCA EXAGONAL M6 LATON	HEXAGONAL NUT M6 BRASS	5			
	Q262040000	ARANDELA GROW. A6 A.304	WASHER GROW. A6 A.304	5			
22	Q307053000	JUNTA TORICA 43.82X54.48X5.35	"O" RING 43.82X54.48X5.35	1			
23	Z393005000	TERMOSTATO CALDERIN	WASH DRUM THERMOSTAT	1			
	Q152024000	TORNILLO AVELLANADO M4X8 A304	COUNTERSUNK BOLT M4X8 A304	2			
24	N503017000	SOPORTE TERMOSTATO 1001713	THERMOSTAT SUPPORT 1001713	1			
25	Z718405000	TERMOSTATO DOBLE	DOUBLE THERMOSTAT	1			
26	V817100000	CONDENSADOR 6 M.F.	CONDENSER 6 M.F.	1			
27	12023830	LIMITADOR TECASA P.	TECASA P. LIMITER	1			
28	12022151	AMARRE LIMITADOR TECASA	LIMITER FASTENING	1			

Зип Общепит

vsezip.ru

+7(812)987-08-81

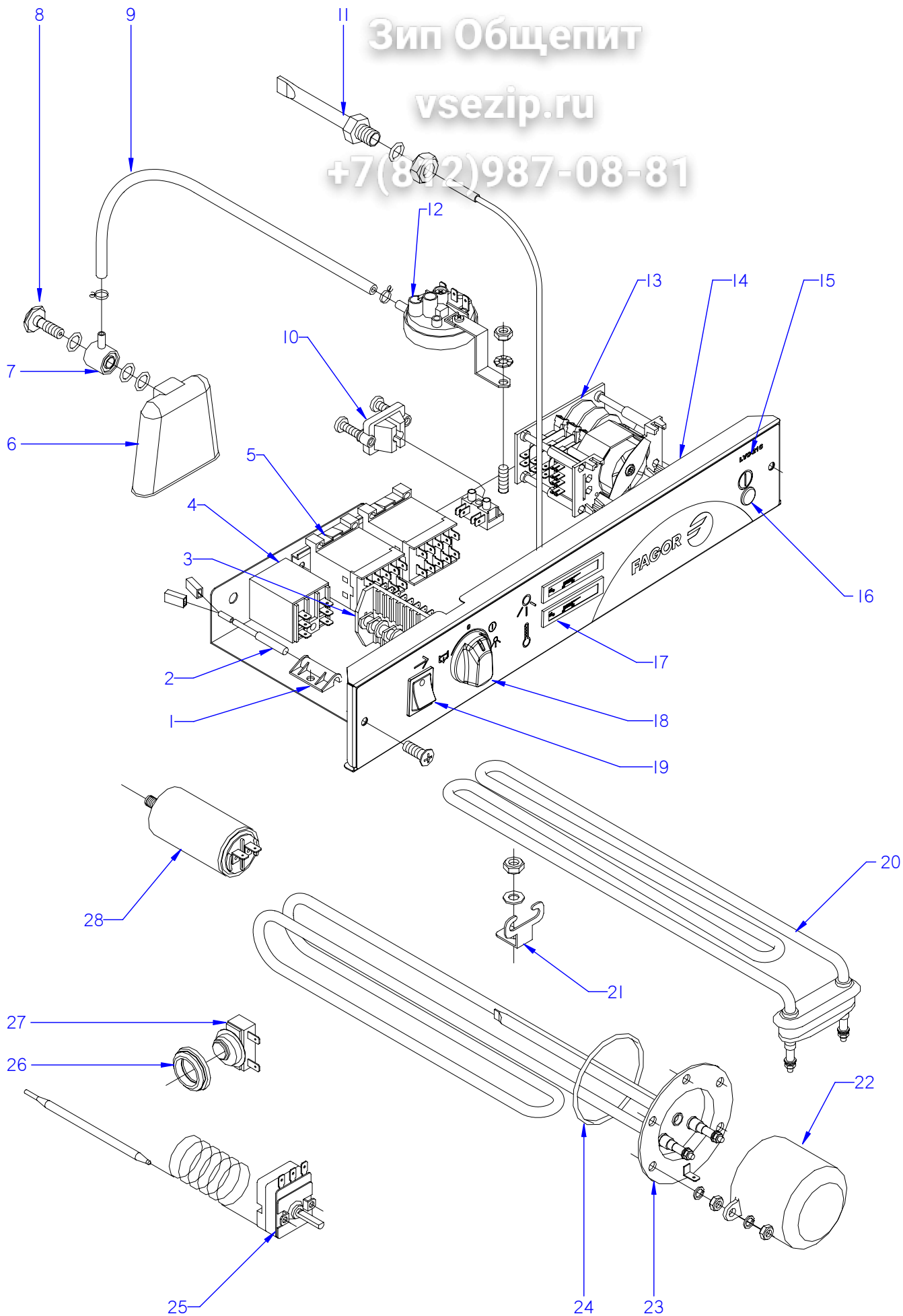

ITEM MARCADO EN COLOR = REPUESTO RECOMENDADO
COLOURED ITEM = RECOMMENDED SPARE PART

N plano	Firma	Fecha	Aparato	CONJUNTO FUNCIONAL ELECTRICO	Lamina	Fagor Industrial S.Coop. FAGOR
C-2121	<i>[Signature]</i>	2009-10	LAVAVASOS LVC-21C		12	Oñate

MOD.	LAVAVASOS	ZONA	CONJUNTO FUNCIONAL ELECTRICO
-------------	------------------	-------------	-------------------------------------

ITEM	CODIGO	DENOMINACION	TEXTO	LVC-21C			
1	Z203010000	AMARRE INTERRUPT. MAGNETICO	MAGNETIC SWITCH FASTENER	1			
2	Z203009000	INTERRUPTOR MAGNETICO	MAGNETIC SWITCH	1			
3	Z433001000	CONMUTADOR DE FUNCIONES	FUNCTIONS SWITCH	1			
4	Z203062000	RELE 230V. 16A 50-60 HZ	RELAY 230V. 16A 50-60 HZ	1			
5	Z203050000	CONTACT. SIRIUS 3R 230 V.50-60 HZ	CONTACT. SIRIUS 3R 230 V.50/60	1			
5	Z213007000	CONTACTOR 230 V. 50-60 HZ	CONTACTOR 230 V. 50-60 HZ	1			
6	Z203011000	CAMARA PRESOSTATO	PRESSURE SWITCH	1			
7	Z203012000	EMPALME PRESOSTATO	PRESSURE SWITCH CONNEX	1			
8	Z203013000	TORNILLO PRESOSTATO	PRESSURE SWITCH BOLT	1			
	Q307003000	JUNTA TORICA 16.01X10.77X2.62	O-RING 16.01X10.77X2.62	3			
9	3702400000	TUBO GOMA NEGRO D 8*4	BLACK RUBBER PIPE Ø 8*4	1			
	P102154000	BRIDA ELASTICA TUBO	ELASTIC PIPE FLANGE	2			
10	Z203020000	RETENEDOR DE CABLE	CABLE HOLDER	1			
	Z603025000	REGLETA DE CONEXIONES	CONNECTION STRIP	1			
	Q032021000	TORNILLO ALOMADO M4X10	CURVED SCREW M4X10	1			
	Q162020000	TUERCA EXAGONAL M4	HEXAGONAL NUT M4	1			
11	Z263002000	VAINA INDICADOR COMPLETA	COMPLETE INDICATOR SHELL	1			
	Q306024000	JUNTA TORICA 18x12,5x1,5	O-RING 18x12.5x1.5	1			
	Q162070000	TUERCA EXAGONAL M12	HEXAGONAL NUT M12	1			
12	Z433011000	PRESOSTATO DOBLE	DOUBLE PRESSURE SWITCH	1			
	Z602923000	SOPORTE PRESOSTATO	PRESSURE SWITCH SUPPORT	1			
	Q082032000	TORNILLO ALOMADO BZ-3,5X9,5	CURVED SCREW BZ-3.5x9.5	1			
	Q152004000	TORNILLO APLASTADO M5x13 A304	FLAT HEADED BOLT M5x13 A304	1			
	Q242030000	ARANDELA ABANICO A5 A.304	FAN WASHER A5 A.304	1			
	Q162030000	TUERCA EXAGONAL M5	HEXAGONAL NUT M5	1			
13	Z433002000	PROGRAMADOR CICLO	CYCLE PROGRAMMER	1			
	Z203007000	CASQUILLO	BUSHING	2			
	Q041324000	TORN. AVELLANADO M4X25 H.ZINC	HEXAGONAL COUNTERSUNK M4	2			
14	Z442905000	FRENTE COMPLETO 21	COMPLETE FRONT 21	1			
	Q152004000	TORNILLO APLASTADO M5x13 A304	FLAT HEADED BOLT M5x13 A304	2			
15	Z208922000	EMBELLECEDOR ADHES. LVC-21C	ADHES. TRIM LVC-21C	1			

MOD.	LAVAVASOS	ZONA	CONJUNTO FUNCIONAL ELECTRICO
------	-----------	------	------------------------------

ITEM	CODIGO	DENOMINACION	TEXTO	LVC-21C				
16	R693056000	PILOTO AMBAR 41227000A4	AMBER PILOT 41227000A4	1				
17	Z203072000	INDICADOR ANALOGICO	ANALOG INDICATOR	2				
18	Z203069000	BOTON DE MANDO	CONTROL BUTTON	1				
19	Z203080000	PULSADOR MARCHA NEGRO	BLACK RUN BUTTON	1				
20	R223005000	RESISTENCIA TANQUE	TANK RESISTOR	1				
21	Z603602000	SOPORTE RESISTENCIATANQUE	TANK RESISTOR SUPPORT	1				
	Q232040000	ARANDELA A6	WASHER A6	1				
	Q162040000	TUERCA EXAGONAL M6	HEXAGONAL NUT M6	1				
22	Z401713000	CAPERUZA RESISTENC. CALDERIN	BOILER RESIST. CAP	1				
	Q163140000	TUERCA EXAGONAL M6 LATON	HEXAGONAL NUT M6 BRASS	2				
	Q242030000	ARANDELA ABANICO A5 A.304	FAN WASHER A5 A.304	2				
	Q152004000	TORNILLO APLASTADO M5x13 A304	FLAT HEADED BOLT M5x13 A304	2				
23	Z421712000	RESISTENCIACALDERIN 2800W	BOILER RESISTOR 2800W	1				
	Q221301000	TUERCA EXAG.AUTOBLOCANTE M6	SELF-LOCK HEX NUT M6	2				
	Q163140000	TUERCA EXAGONAL M6 LATON	HEXAGONAL NUT M6 BRASS	5				
	Q262040000	ARANDELA GROW. A6 A.304	WASHER GROW. A6 A.304	5				
24	Q307053000	JUNTA TORICA 43.82X54.48X5.35	"O" RING 43.82X54.48X5.35	1				
25	Z393005000	TERMOSTATO CALDERIN	WASH DRUM THERMOSTAT	1				
	Q152024000	TORNILLO AVELLANADO M4X8 A304	COUNTERSUNK BOLT M4X8 A304	2				
26	N503017000	SOPORTE TERMOSTATO 1001713	THERMOSTAT SUPPORT 100171	1				
27	Z718405000	TERMOSTATO DOBLE	DOUBLE THERMOSTAT	1				
28	V817100000	CONDENSADOR 6 M.F.	CONDENSER 6 M.F.	1				

Зип Общепит

vsezip.ru

+7(812)987-08-81

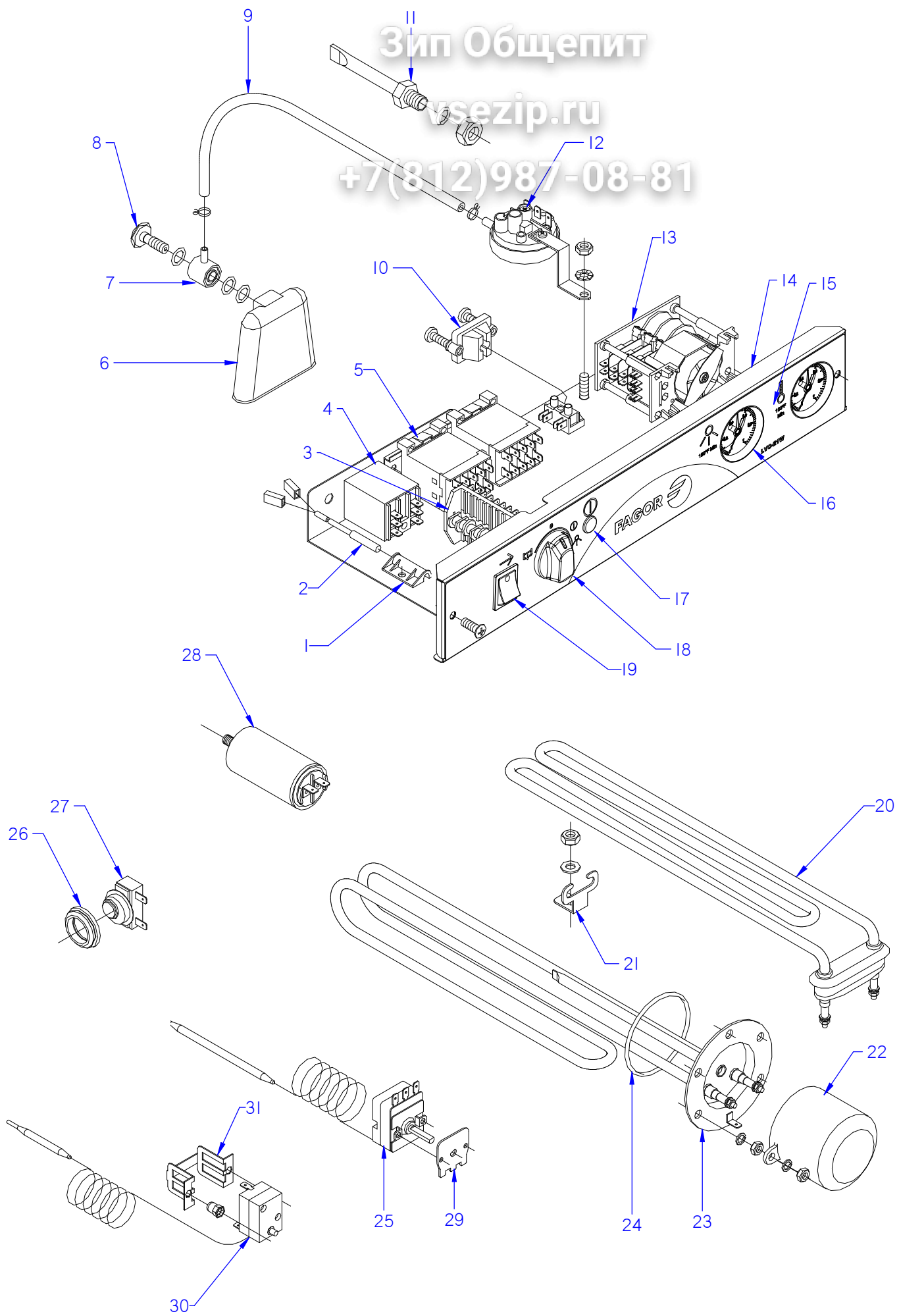

ITEM MARCADO EN COLOR = REPUESTO RECOMENDADO
COLOURED ITEM = RECOMMENDED SPARE PART

N plano	Firma	Fecha	Aparato	CONJUNTO FUNCIONAL ELECTRICO	Lamina	Fagor Industrial S.Coop. FAGOR
C-2122	<i>[Signature]</i>	2009-10	LAVAVASOS LVC-21W		13	Oñate

MOD.	LAVAVASOS	ZONA	CONJUNTO FUNCIONAL ELECTRICO
-------------	------------------	-------------	-------------------------------------

ITEM	CODIGO	DENOMINACION	TEXTO	LVC-21W				
1	Z203010000	AMARRE INTERRUPT. MAGNETICO	MAGNETIC SWITCH FASTENER	1				
2	Z203009000	INTERRUPTOR MAGNETICO	MAGNETIC SWITCH	1				
3	Z433001000	CONMUTADOR DE FUNCIONES	FUNCTIONS SWITCH	1				
4	Z203062000	RELE 230V. 16A 50-60 HZ	RELAY 230V. 16A 50-60 HZ	1				
4	Z203062000	RELE 230V. 16A 50-60 HZ	RELAY 230V. 16A 50-60 HZ	2				
5	Z203050000	CONTACT. SIRIUS 3R 230 V.50-60 HZ	CONTACT. SIRIUS 3R 230 V.50/60	1				
5	12024011	CONTACTOR 230 V. 50-60 HZ	CONTACTOR 230 V. 50-60 HZ	1				
5	12024011	CONTACTOR 230 V. 50-60 HZ	CONTACTOR 230 V. 50-60 HZ	2				
6	Z203011000	CAMARA PRESOSTATO	PRESSURE SWITCH	1				
7	Z203012000	EMPALME PRESOSTATO	PRESSURE SWITCH CONNEX	1				
8	Z203013000	TORNILLO PRESOSTATO	PRESSURE SWITCH BOLT	1				
	Q307003000	JUNTA TORICA 16.01X10.77X2.62	O-RING 16.01X10.77X2.62	3				
9	3702400000	TUBO GOMA NEGRO D 8*4	BLACK RUBBER PIPE Ø 8*4	1				
	P102154000	BRIDA ELASTICA TUBO	ELASTIC PIPE FLANGE	2				
10	Z203020000	RETENEDOR DE CABLE	CABLE HOLDER	1				
	U183046000	REGLETA AUXILIAR	AUXILIARY STRIP	1				
	Q032021000	TORNILLO ALOMADO M4X10	CURVED SCREW M4X10	2				
	Q162020000	TUERCA EXAGONAL M4	HEXAGONAL NUT M4	2				
11	Z263002000	VAINA INDICADOR COMPLETA	COMPLETE INDICATOR SHELL	1				
	Q306024000	JUNTA TORICA 18x12,5x1,5	O-RING 18x12.5x1.5	1				
	Q162070000	TUERCA EXAGONAL M12	HEXAGONAL NUT M12	1				
12	Z433011000	PRESOSTATO DOBLE	DOUBLE PRESSURE SWITCH	1				
	Z602923000	SOPORTE PRESOSTATO	PRESSURE SWITCH SUPPORT	1				
	Q082032000	TORNILLO ALOMADO BZ-3,5X9,5	CURVED SCREW BZ-3.5x9.5	1				
	Q152004000	TORNILLO APLASTADO M5x13 A304	FLAT HEADED BOLT M5x13 A304	1				
	Q162030000	TUERCA EXAGONAL M5	HEXAGONAL NUT M5	1				
13	Z448302000	PROGRAMADOR CICLO 2' 60HZ	CYCLE PROGRAMMER 2' 60HZ	1				
	Z203007000	CASQUILLO	BUSHING	2				
	Q041324000	TORN. AVELLANADO M4X25 H.ZINC.	HEXAGONAL COUNTERSUNK M4	2				
14	Z458407000	FRENTE COMPLETO 21W	COMPLETE FRONT 21W	1				
	Q152004000	TORNILLO APLASTADO M5x13 A304	FLAT HEADED BOLT M5x13 A304	2				

MOD.		LAVAVASOS		ZONA		CONJUNTO FUNCIONAL ELECTRICO			
ITEM	CODIGO	DENOMINACION	TEXTO	LVC-21W					
15	Z458406000	EMBELLECEDOR ADHE. LVC-21W	ADHES. TRIM LVC-21W	1					
16	Z273060000	TERMOMETRO W NSF	THERMOMETER W NSF	2					
17	R693056000	PILOTO AMBAR 41227000A4	AMBER PILOT 41227000A4	1					
18	Z203069000	BOTON DE MANDO	CONTROL BUTTON	1					
19	Z203080000	PULSADOR MARCHA NEGRO	BLACK RUN BUTTON	1					
19	Z513022000	PULSADOR NEGRO	BLACK BUTTON	1					
20	R223005000	RESISTENCIA TANQUE	TANK RESISTOR	1					
21	Z603602000	SOPORTE RESISTENCIATANQUE	TANK RESISTOR SUPPORT	1					
	Q232040000	ARANDELA A6	WASHER A6	1					
	Q162040000	TUERCA EXAGONAL M6	HEXAGONAL NUT M6	1					
22	Z401713000	CAPERUZA RESISTENC. CALDERIN	BOILER RESIST. CAP	1					
	Q163140000	TUERCA EXAGONAL M6 LATON	HEXAGONAL NUT M6 BRASS	2					
	Q242030000	ARANDELA ABANICO A5 A.304	FAN WASHER A5 A.304	2					
	Q152004000	TORNILLO APLASTADO M5x13 A304	FLAT HEADED BOLT M5x13 A304	2					
23	Z421712000	RESISTENCIACALDERIN 2800W	BOILER RESISTOR 2800W	1					
	Q221301000	TUERCA EXAG.AUTOBLOCANTE M6	SELF-LOCK HEX NUT M6	2					
	Q163140000	TUERCA EXAGONAL M6 LATON	HEXAGONAL NUT M6 BRASS	5					
	Q262040000	ARANDELA GROW. A6 A.304	WASHER GROW. A6 A.304	5					
24	Q307053000	JUNTA TORICA 43.82X54.48X5.35	"O" RING 43.82X54.48X5.35	1					
25	Z393005000	TERMOSTATO CALDERIN	WASH DRUM THERMOSTAT	1					
	Q152024000	TORNILLO AVELLANADO M4X8 A304	COUNTERSUNK BOLT M4X8 A304	2					
26	N503017000	SOPORTE TERMOSTATO 1001713	THERMOSTAT SUPPORT 1001713	1					
27	Z718441000	TERMOSTATO DOBLE W	DOUBLE THERMOSTAT W	1					
28	V817100000	CONDENSADOR 6 M.F.	CONDENSER 6 M.F.	1					
29	12021987	CHAPA W 85°C	W 85°C PLATE	1					
30	12023830	LIMITADOR TECASA P.	TECASA P. LIMITER	1					
31	12022151	AMARRE LIMITADOR TECASA	LIMITER FASTENING	1					

Зип Общепит

usezip.ru

+7(812)987-08-81

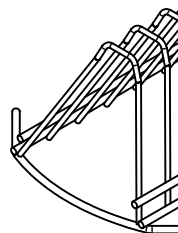
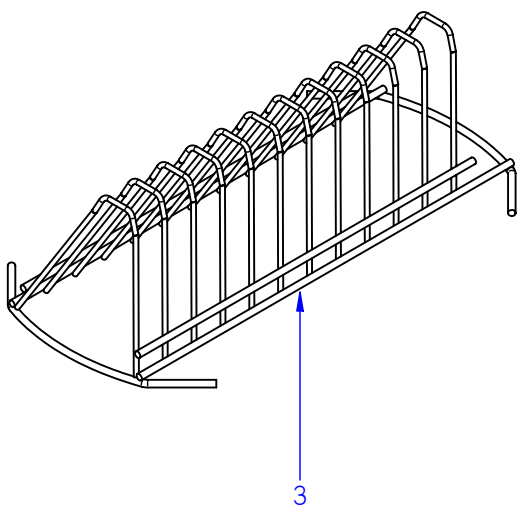
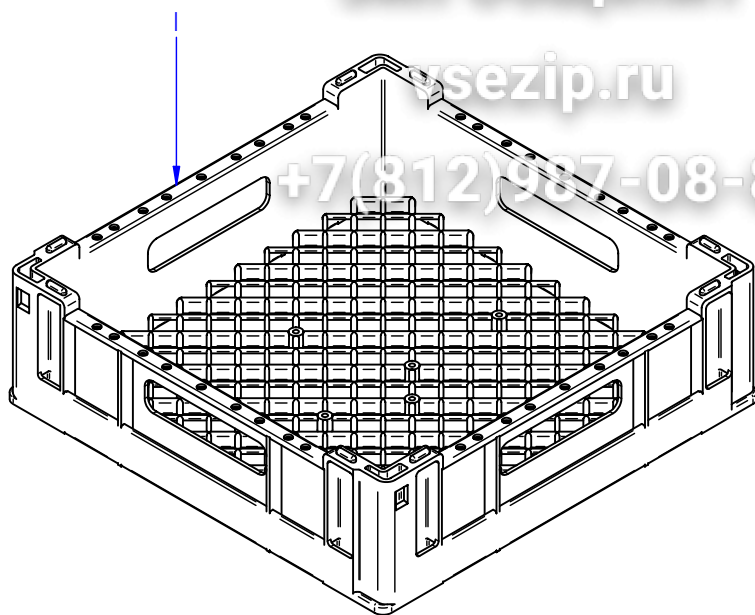

N plano	Firma	Fecha	Aparato	Lamina	Orden
C-2123	<i>(Firma)</i>	2009-10	LAVAVASOS LVC	14	Fagor Industrial S. Coop. FAGOR

ITEM MARCADO EN COLOR = REPUESTO RECOMENDADO
COLOURED ITEM = RECOMMENDED SPARE PART



Зип Оффепит

		LAVAVASOS		CESTILLOS						
MOD.		LAVAVASOS			ZONA					
ITEM	CODIGO	DENOMINACION	TEXTO	LVC-12	LVC-15	LVC-15D	LVC-21	LVC-21D	LVC-21D	
1	Z415320000	CESTILLO LVC-12/15	BASKET LVC-12/15	2	2	2	_	_	_	
1	Z445320000	CESTILLO LVC-21	BASKET LVC-21	_	_	_	2	2	_	
2	Z605303000	CESTILLO CUBIERTOS	CUTLERY BASKET	1	1	1	1	1	1	
3	Z605302000	SUPLEMENT. CESTILLOS LAVA.-12	SUPPLEMENT. WASH BASKET.-1	1	_	_	_	_	_	
3	Z605302000	SUPLEMENT. CESTILLOS LAVA.-12	SUPPLEMENT. WASH BASKET.-1	_	1	1	_	_	_	
4	Z625302000	SUPLEMENT. PLATILLOS LAVAV.18	SUPPLEMENT. GLASS WASHER	_	_	_	1	1	1	

MOD.		LAVAVASOS		ZONA		VARIOS				
ITEM	CODIGO	DENOMINACION	TEXTO	LVC-12	LVC-15	LVC-15D	LVC-21	LVC-21D		
	Z406132000	FOLLETO INSTRUCCIONES	INSTRUCTION LEAFLET.	1	1	1	1	1		
	Z408432000	FOLLETO INSTRUCCIONES	INSTRUCTION LEAFLET.	-	-	-	-	-		
	Z393010000	ESQUEMA TEORICO ADH. LVC-12	THEORETICAL. DIAGRAM ADHE.	1	-	-	-	-		
	Z403014000	ESQUEMA TEORICO ADH. LVC-15	THEORETICAL DIAGRAM ADHE.	1	-	-	-	-		
	Z403014000	ESQUEMA TEORICO ADH. LVC-15	THEORETICAL DIAGRAM ADHE.	-	1	-	1	-		
	Z473002000	ESQUEMA TEORICO AD. LVC-15D	THEORETICAL DIAGRAM ADHE.	-	-	1	-	1		
	Z433009000	ESQUEMA TEORICO AD. LVC-21B	THEORETICAL DIAGRAM ADHE.	-	-	-	-	-		
	Z438402000	ESQUEMA TEORICO AD. LVC-21W	THEORETICAL DIAGRAM ADHE.	-	-	-	-	-		
	Z393035000	ESQUEMA MONTAJE LVC-12	ASSEMBLY DIAGRAM LVC-12	1	-	-	-	-		
	Z403035000	ESQUEMA MONTAJE LVC-15	ASSEMBLY DIAGRAM LVC-15	-	1	-	1	-		
	Z473035000	ESQUEMA MONTAJE LVC-15D	ASSEMBLY DIAGRAM LVC-15D	-	-	1	-	1		
	12046369	ESQUE. MONTAJE LVC, 21, 15, 12	ASSEMBLY DIA. LVC, 21, 15, 12	1	1	-	1	-		
	Z433035000	ESQUEMA MONTAJE LVC-21B	ASSEMBLY DIAGRAM LVC-21B	-	-	-	-	-		
	12046409	ESQUEMA MONTAJE LVC-21B	ASSEMBLY DIAGRAM LVC-21B	-	-	-	-	-		
	Z433036000	ESQUEMA MONTAJE LVC-21W	ASSEMBLY DIAGRAM LVC-21W	-	-	-	-	-		
	Z393001000	INSTALACION ELECTRICA	ELECTRIC INSTALLATION	1	-	-	-	-		
	Z403011000	INSTALACION ELECTRICA	ELECTRIC INSTALLATION	-	1	1	1	1		
	12046167	INSTALA. ELECTRICA LVC 21,15	ELECTRIC INSTALL. LVC 21,15	1	1	1	1	1		
	12046168	INSTALA. ELECTRICA LVC 21,15B	ELECTRIC INSTALL. LVC 21,15B	-	-	-	-	-		
	12023746	CABLE ALIMENTACION	SUPPLY CABLE	1	1	1	1	1		
	12023974	CABLE DE ALIMENTACION USA	POWER CABLE USA	-	-	-	-	-		
	12025003	CABLEADO BOMBA DESAGÜE	DRAINAGE PUMP WIRING	-	-	-	-	-		
	12024183	CABLEADO TIERRA M.BOMBA	PUMP LAND WIRING	1	1	1	1	1		
S/Nº	12024314	CABLEADO DOSIFICADOR DTGTE.	DETERGENT DISP. WIRING	-	-	-	-	-		

Зип Общепит

MOD. LAVAVASOS		ZONA PIEZAS ESPECIFICAS PARA LA VERSION						
ITEM	CODIGO	DENOMINACION	TEXTO	LVC-21B AR UK				
	Z208912000	RESIST. CALDERIN COMP. 2200W	COMP. BOILER RESIST. 2200W	1				
	Z468901000	CABLE DE ALIMENTACION UK	POWER CABLE UK	1				

MOD.		LAVAVASOS		ZONA		PIEZAS ESPECIFICAS PARA LA VERSION AZKOYEN			
ITEM	CODIGO	DENOMINACION	TEXTO	A-9 (LVC-12)	A-15 (LVC-15)	A-21 (LVC-21)	A-21B (LVC-21B)		
	Z658602000	ASA PUERTA GRIS RAL 7039	DOOR HANDLE GREY RAL 7039	1	1	1	1		
	Z230902000	PASAMUROS DETERGENTE	DETERGENT WALL BUSHING	1	1	1	1		
	Z448614000	CONDUCTO ASPIRAC. AZKOYEN	EXTRACTOR PIPE. AZKOYEN	1	1	1	1		
	Z448616000	PEGATINA TOMA DETERGENTE	DETERGENT INTAKE LABEL	1	1	1	1		
	Z468601000	EMBELLECEDOR ADHESIVO A-9	ADHESIVE TRIM A-9	1					
	Z418601000	EMBELLECEDOR ADHESIVO A-15	ADHESIVE TRIM A-15		1				
	Z448601000	EMBELLECEDOR ADHESIVO A-21	ADHESIVE TRIM A-21			1			
	Z458601000	EMBELLECEDOR ADHESIVO A-21B	ADHESIVE TRIM A-21B				1		
	Z402907000	FRENTE EXTRAIBLE A-9	REMOVABLE FRONT A-9	1					
	Z418602000	FRENTE EXTRAIBLE A-15	REMOVABLE FRONT A-15		1				
	Z448612000	FRENTE EXTRAIBLE A-21	REMOVABLE FRONT A-21			1			
	Z432903000	FRENTE EXTRAIBLE 20B-21B	REMOVABLE FRONT 20B-21B				1		
	Z658813000	BOTON DE MANDO	CONTROL BUTTON	1	1	1	1		
	Z658607000	INDICADOR	INDICATOR	1	1	1	1		
	Z203033000	INTERRUPTOR GENERAL	POWER SWITCH	1	1	1			
	Z410311000	CAJA SOLDADA AZKOYEN 12-15	WELDED BOX AZKOYEN 12-15	1	1				
	Z440311000	CAJA SOLDADA AZKOYEN 21	WELDED BOX AZKOYEN 21			1			
	Z458811000	CAJA SOLDADA AZKOYEN 21B	WELDED BOX AZKOYEN 21B				1		
	Z448613000	CABLE DOSIFICADOR AZKOYEN	DISP. CABLE AZKOYEN	1	1	1	1		
	R693055000	PILOTO VERDE 41227000C7	GREEN PILOT 41227000C7		1	1	1		
	Z403033000	PULSADOR ACLARADO	RINSE BUTTON		1	1			
	Z213033000	PULSADOR MARCHA	START BUTTON				1		
	Z213007000	CONTACTOR 230 V. 50-60 HZ	CONTACTOR 230 V. 50-60 HZ		1	2			
	Z468631000	FOLLETO DE INSTRUCCIONES	INSTRUCTION LEAFLET	1	1	1	1		

MOD.		LAVAVASOS		ZONA	PIEZAS ESPECIFICAS PARA LA VERSION ASPES		
ITEM	CODIGO	DENOMINACION	TEXTO	LAB-1200 C (LVC-12)	LAB-1500 C (LVC-15)	LAB-2100 C (LVC-21)	
	Z448720000	ARMAZON COMPLETO	COMPLETE FRAME	=	=	1	
	Z468736000	ESCUADRA AMARRE TAPA ASPES	ATTACHMENT BRACKET COVER	2	2	=	
	Z448736000	ESCUADRA AMARRE TAPA ASPES	ATTACHMENT BRACKET COVER	2	2	2	
	Z468740000	PUERTA COMPLETA	COMPLETE DOOR	1	1	=	
	Z448740000	PUERTA COMPLETA	COMPLETE DOOR	=	=	1	
	Z468711000	PASAMUROS CESTO CUADRADO	SQUARE BASKET WALL BUSHING	1	=	=	
	Z468710000	SOPORTE ACLARADO SUPERIOR	UPPER RINSE SUPPORT	1	=	=	
	Z201903000	SOPORTE RAMAS ACLARADO	RINSE BRANCH SUPPORT	1	=	=	
	Z468713000	RAMA ACLARADO A ASPES	RINSE BRANCH A ASPES	1	=	=	
	Z468712000	RAMA ACLARADO B ASPES	RINSE BRANCH B ASPES	1	=	=	
	Z448713000	RAMA ACLARADO A ASPES	RINSE BRANCH A ASPES	=	=	1	
	Z448712000	RAMA ACLARADO B ASPES	RINSE BRANCH B ASPES	=	=	1	
	Z201905000	TOBERA ACLARADO	RINSE NOZZLE	=	=	10	
	Z201906000	ENGANCHE TOB. ACLA.19728	NOZZLE LATCH RINSE.19728	=	=	10	
	Z468765000	ADHESIVO ASPES LAB-1200 C	ADHESIVE ASPES LAB-1200 C	1	=	=	
	Z418765000	ADHESIVO ASPES LAB-1500 C	ADHESIVE ASPES LAB-1500 C	=	1	=	
	Z448765000	ADHESIVO ASPES LAB-2100 C	ADHESIVE ASPES LAB-2100 C	=	=	1	
	Z468734000	FRENTE EXTRAIBLE ASPES	REMOVABLE FRONT ASPES	1	1	=	
	Z448734000	FRENTE EXTRAIBLE ASPES	REMOVABLE FRONT ASPES	=	=	1	
	Z448737000	PANEL POSTERIOR ASPES	REAR PANEL ASPES	=	=	1	
	Z214902000	BOTON DE MANDO COMPLETO	COMPLETE CONTROL BUTTON	1	1	1	
	Z203033000	INTERRUPTOR GENERAL	POWER SWITCH	1	1	1	
	Z203062000	RELE 230V. 16A 50-60 HZ	RELAY 230V. 16A 50-60 HZ	1	=	=	
	R693055000	PILOTO VERDE 41227000C7	GREEN PILOT 41227000C7	=	1	1	
	Z403033000	PULSADOR ACLARADO	RINSE BUTTON	=	1	1	

MOD.	LAVAVASOS	ZONA	PIEZAS ESPECIFICAS PARA LA VERSION MOVILFRIT		
-------------	------------------	-------------	---	--	--

ITEM	CODIGO	DENOMINACION	TEXTO	MLV-35 (LVC-12)	MLV-35 S (LVC-15)	MLV-35 D (LVC-15D)	MLV-40 (LVC-21)	MLV-40-D
	Z468740000	PUERTA COMPLETA	COMPLETE DOOR	1	1	1	-	-
	Z468004000	PUERTA COMPLETA EDESA	COMPLETE DOOR EDESA	1	1	1	-	-
	Z464602000	ASA CHAPA LVS	HANDLE LVS	1	1	1	1	1
	Z448740000	PUERTA COMPLETA	COMPLETE DOOR	-	-	-	1	1
	Z448003000	PUERTA COMPLETA EDESA	COMPLETE DOOR EDESA	-	-	-	1	1
	Z464401000	EMBELLECE. ADHESIVO MLV-35	ADHESIVE TRIM MLV-35.	1	-	-	-	1
	Z414401000	EMBELLECE. ADHESIVO MLV-35 S	ADHESIVE TRIM MLV-35S.	-	1	-	-	-
	Z484401000	EMBELLECE. ADHESIVO MLV-35-D	ADHESIVE TRIM MLV-35-D.	-	-	1	-	-
	Z444401000	EMBELLECE. ADHESIVO MLV-40	ADHESIVE TRIM MLV-40.	-	-	-	1	-
	Z504401000	EMBELLECE. ADHESIVO MLV-40-D	ADHESIVE TRIM MLV-40-D.	-	-	-	-	1
	Z454401000	EMBELLECE. ADHESIVO MLV-40-B	ADHESIVE TRIM MLV-40-B.	-	-	-	-	-
	Z402907000	FRENTE EXTRAIBLE	REMOVABLE FRONT	1	1	-	-	-
	Z472901000	FRENTE EXTRAIBLE	REMOVABLE FRONT	-	-	1	-	-
	Z422907000	FRENTE EXTRAIBLE	REMOVABLE FRONT	-	-	-	1	-
	Z492901000	FRENTE EXTRAIBLE	REMOVABLE FRONT	-	-	-	-	1
	Z432903000	FRENTE EXTRAIBLE	REMOVABLE FRONT	-	-	-	-	-
	Z663062000	BOTON DE MANDO	CONTROL BUTTON	1	1	2	1	2
	Z203033000	INTERRUPTOR GENERAL	POWER SWITCH	1	1	-	1	-
	R693055000	PILOTO VERDE 41227000C7	GREEN PILOT 41227000C7	-	1	1	1	1
	Z403033000	PULSADOR ACLARADO	RINSE BUTTON	-	1	1	1	1
	Z213033000	PULSADOR MARCHA	START BUTTON	-	-	-	-	-

MOD.	LAVAVASOS	ZONA	PIEZAS ESPECIFICAS PARA LA VERSION CELIKAY
-------------	------------------	-------------	---

vsezip.ru

+7(812)987-08-80

ITEM	CODIGO	DENOMINACION	TEXTO	CBY-1200 (LVC-12)			
	Z468736000	ESCUADRA AMARRE TAPA	COVER FASTENING BRACKET	2			
	Z468740000	PUERTA COMPLETA	COMPLETE DOOR	1			
	Z468711000	PASAMUROS CESTO CUADRADO	SQUARE BASKET WALL BUSHING	1			
	Z468710000	SOPORTE ACLARADO SUPERIOR	UPPER RINSE SUPPORT	1			
	Z201903000	SOPORTE RAMAS ACLARADO	RINSE BRANCH SUPPORT	1			
	Z468713000	RAMA ACLARADO A ASPES	RINSE BRANCH A ASPES	1			
	Z468712000	RAMA ACLARADO B ASPES	RINSE BRANCH B ASPES	1			
	Z468203000	EMBELLEC. ADHESIVO CELIKAY	ADHESIVE TRIM CELIKAY.	1			
	Z468734000	FRENTE EXTRAIBLE	REMOVABLE FRONT	1			
	R663062000	BOTON DE MANDO	CONTROL BUTTON	1			
	Z203033000	INTERRUPTOR GENERAL	POWER SWITCH	1			
	Z203062000	RELE 230V. 16A 50-60 HZ	RELAY 230V. 16A 50-60 HZ	1			

+7(812)987-08-80

MOD.	LAVAVASOS		ZONA	PIEZAS ESPECIFICAS PARA LA VERSION DIVA		
ITEM	CODIGO	DENOMINACION	TEXTO	DBY-1000 (LVC-12)		
	Z468736000	ESCUADRA AMARRE TAPA	COVER FASTENING BRACKET	2		
	Z650531000	ASA PUERTA NEGRA	BLACK DOOR HANDLE	1		
	Z400545000	ASA NEGRA	BLACK HANDLE	1		
	Z468711000	PASAMUROS CESTO CUADRADO	SQUARE BASKET WALL BUSHING	1		
	Z468710000	SOPORTE ACLARADO SUPERIOR	UPPER RINSE SUPPORT	1		
	Z201903000	SOPORTE RAMAS ACLARADO	RINSE BRANCH SUPPORT	1		
	Z468713000	RAMA ACLARADO A ASPES	RINSE BRANCH A ASPES	1		
	Z468712000	RAMA ACLARADO B ASPES	RINSE BRANCH B ASPES	1		
	Z468202000	EMBELLECEDOR ADHESIVO DIVA	ADHESIVE TRIM DIVA	1		
	Z468734000	FRENTE EXTRAIBLE	REMOVABLE FRONT	1		
	Z214902000	BOTON DE MANDO	CONTROL BUTTON	1		
	Z203033000	INTERRUPTOR GENERAL	POWER SWITCH	1		
	Z203062000	RELE 230V. 16A 50-60 HZ	RELAY 230V. 16A 50-60 HZ	1		

MOD.		LAVAVASOS		ZONA	PIEZAS ESPECIFICAS PARA LA VERSION CORECO				
ITEM	CODIGO	DENOMINACION	TEXTO	CLV-12 (LVC-12)	CLV-15 (LVC-15)	CLV-15 CD (LVC-15D)	CLV-21 C (LVC-21)	CLV-21 CD	
	Z464602000	ASA CHAPA LVS	PLATE HANDLE LVS	1	1	1	1	1	
	Z468101000	EMBELLECEDOR ADHESIV. CLV-12	ADHESIVE TRIM CLV-12	1	-	-	-	-	
	Z418101000	EMBELLECEDOR ADHESIV. CLV-15	ADHESIVE TRIM CLV-15	-	1	-	-	-	
	Z488101000	EMBELLECEDOR ADHE. CLV-15-D	ADHES. TRIM CLV-15-D	-	-	1	-	-	
	Z448101000	EMBELLECEDOR ADHE. CLV-21-C	ADHES. TRIM CLV-21-C	-	-	-	1	-	
	Z508101000	EMBELLECEDOR ADH. CLV-21-CD	ADHES. TRIM CLV-21-CD	-	-	-	-	1	
	Z402907000	FRENTE EXTRAIBLE	REMOVABLE FRONT	1	1	-	-	-	
	Z472901000	FRENTE EXTRAIBLE	REMOVABLE FRONT	-	-	1	-	-	
	Z422907000	FRENTE EXTRAIBLE	REMOVABLE FRONT	-	-	-	1	-	
	Z492901000	FRENTE EXTRAIBLE	REMOVABLE FRONT	-	-	-	-	1	
	R663062000	BOTON DE MANDO	CONTROL BUTTON	1	1	2	1	2	
	Z203033000	INTERRUPTOR GENERAL	POWER SWITCH	1	1	-	1	-	
	R693055000	PILOTO VERDE 41227000C7	GREEN PILOT 41227000C7	-	1	1	1	1	
	Z403033000	PULSADOR ACLARADO	RINSE BUTTON	-	1	1	1	1	

Зип Ощепит

vsezip.ru

+7(812)987-08-81

	MOD.	LAVAVASOS	ZONA	PIEZAS ESPECIFICAS PARA LA VERSION DOCRILUC					
ITEM	CODIGO	DENOMINACION	TEXTO	DLV-12 (LVC-12)	DLV-15 (LVC-15)	DLV-15D (LVC-15D)	DLV-21 (LVC-21)	DLV-21-D	
	Z464602000	ASA CHAPA LVS	PLATE HANDLE LVS	1	1	1	1	1	
	Z468633000	ASA	HANDLE	1	1	1	1	1	
	Z461401000	EMBELLECEDOR ADHESIV. DLV-12	ADHESIVE TRIM DLV-12	1	-	-	-	-	
	Z411401000	EMBELLECEDOR ADHESIV. DLV-15	ADHESIVE TRIM DLV-15	-	1	-	-	-	
	Z481401000	EMBELLECEDOR ADHE. DLV-15-D	ADHES. TRIM DLV-15-D	-	-	1	-	-	
	Z441401000	EMBELLECEDOR ADHES DLV-21	ADHESIVE TRIM DLV-21	-	-	-	1	-	
	Z501401000	EMBELLECEDOR ADHES DLV-21-D	ADHESIVE TRIM DLV-21-D	-	-	-	-	1	
	Z451401000	EMBELLECEDOR ADHES DLV-21-B	ADHESIVE TRIM DLV-21-B	-	-	-	-	-	
	Z402907000	FRENTE EXTRAIBLE	REMOVABLE FRONT	1	1	-	-	-	
	Z472901000	FRENTE EXTRAIBLE	REMOVABLE FRONT	-	-	1	-	-	
	Z422907000	FRENTE EXTRAIBLE	REMOVABLE FRONT	-	-	-	1	-	
	Z492901000	FRENTE EXTRAIBLE	REMOVABLE FRONT	-	-	-	-	1	
	Z432903000	FRENTE EXTRAIBLE 21B	REMOVABLE FRONT 21B	-	-	-	-	-	
	R663062000	BOTON DE MANDO	CONTROL BUTTON	1	1	2	1	2	
	Z203033000	INTERRUPTOR GENERAL	POWER SWITCH	1	1	-	1	-	
	R693055000	PILOTO VERDE 41227000C7	GREEN PILOT 41227000C7	-	1	1	1	1	
	Z403033000	PULSADOR ACLARADO	RINSE BUTTON	-	1	1	1	1	
	Z213033000	PULSADOR MARCHA	START BUTTON	-	-	-	-	-	

MOD.	LAVAVASOS	ZONA	PIEZAS ESPECIFICAS PARA LA VERSION GAGGIA
------	-----------	------	--

vsezip.ru

+7(812)987-08-81

ITEM	CODIGO	DENOMINACION	TEXTO	GX-4C (LVC-15)	GX-5C (LVC-21)			
	Z464602000	ASA CHAPA LVS	PLATE HANDLE LVS	1	1			
	Z414601000	EMBELLECEDOR ADHESIV. GX-4C	ADHESIVE TRIM GX-4C	1	—			
	Z444601000	EMBELLECEDOR ADHESIV. GX-5C	ADHESIVE TRIM GX-5C	—	1			
	Z402907000	FRENTE EXTRAIBLE	REMOVABLE FRONT	1	—			
	Z422907000	FRENTE EXTRAIBLE	REMOVABLE FRONT	—	1			
	Z658813000	BOTON DE MANDO	CONTROL BUTTON	1	1			
	Z203033000	INTERRUPTOR GENERAL	POWER SWITCH	1	1			
	R693055000	PILOTO VERDE 41227000C7	GREEN PILOT 41227000C7	1	1			
	Z403033000	PULSADOR ACLARADO	RINSE BUTTON	1	1			

MOD. **LAVAVASOS** ZONA **PIEZAS ESPECIFICAS PARA LA VERSI**
vsezip.ru **FUTURMAT**

ITEM	CODIGO	DENOMINACION	TEXTO	+7(812)987-08-81				
				FV-20C (LVC-15)	FV-26C (LVC-21)			
	Z464602000	ASA CHAPA LVS	PLATE HANDLE LVS	1	1			
	Z414501000	EMBELLECEDOR ADHESI. FV-20C	ADHES. TRIM FV-20C	1	-			
	Z444501000	EMBELLECEDOR ADHESI. FV-26C	ADHES. TRIM FV-26C	-	1			
	Z402907000	FRENTE EXTRAIBLE	REMOVABLE FRONT	1	-			
	Z422907000	FRENTE EXTRAIBLE	REMOVABLE FRONT	-	1			
	Z204504000	BOTON DE MANDO 6 GRIS	CONTROL BUTTON 6 GREY	1	1			
	Z203033000	INTERRUPTOR GENERAL	POWER SWITCH	1	1			
	R693055000	PILOTO VERDE 41227000C7	GREEN PILOT 41227000C7	1	1			
	Z403033000	PULSADOR ACLARADO	RINSE BUTTON	1	1			

MOD. **LAVAVASOS** ZONA **PIEZAS ESPECIFICAS PARA LA VERSION RESTOMAT**

vsezip.ru

+7(812)987-08-81

ITEM	CODIGO	DENOMINACION	TEXTO	KM-21 (LVC-21)	KM-21B (LVC-21B)			
	Z464602000	ASA CHAPA LVS	PLATE HANDLE LVS	1	1			
	Z444901000	EMBELLECEDOR ADH. RESTOMAT	ADHES. TRIM RESTOMAT	1	-			
	Z454901000	EMBELLECEDOR ADH. RESTOMAT	ADHES. TRIM RESTOMAT	-	1			
	Z422907000	FRENTE EXTRAIBLE	REMOVABLE FRONT	1	-			
	Z432903000	FRENTE EXTRAIBLE	REMOVABLE FRONT	-	1			
	Z214902000	BOTON DE MANDO	CONTROL BUTTON	1	1			
	Z203033000	INTERRUPTOR GENERAL	POWER SWITCH	1	-			
	R693055000	PILOTO VERDE 41227000C7	GREEN PILOT 41227000C7	1	1			
	Z403033000	PULSADOR ACLARADO	RINSE BUTTON	1	1			

MOD. **LAVAVASOS** ZONA **PIEZAS ESPECIFICAS PARA LA VERSION SHARPLINE**

ITEM	CODIGO	DENOMINACION	TEXTO	KM-21 (LVC-21)				
	Z440311000	CAJA SOLDADA 21B (FI+Azk UK)	WELDED BOX 21B (FI+Azk UK)	1				
	Z200512000	ASA PUERTA COOL GRAY 10	DOOR HANDLE COOL GRAY 10	1				
	Z452902000	EMBELLECEDOR ADH. SHARPLINE	ADHES. TRIM SHARPLINE	1				
	Z432903000	FRENTE EXTRAIBLE	REMOVABLE FRONT	1				
	R663062000	BOTON DE MANDO	CONTROL BUTTON	1				
	Z214902000	BOTON DE MANDO	CONTROL BUTTON	1				
	R693055000	PILOTO VERDE 41227000C7	GREEN PILOT 41227000C7	1				
	Z213033000	PULSADOR MARCHA	START BUTTON	1				
	Z203080000	PULSADOR MARCHA NEGRO	BLACK START BUTTON	1				
	Z230902000	PASAMUROS DETERGENTE	DETERGENT WALL BUSHING	1				

MOD.		LAVAVASOS	ZONA	PIEZAS ESPECIFICAS PARA LA VERSION CULION			
ITEM	CODIGO	DENOMINACION	TEXTO	VGL 10 (LVC-21B)			
	Z448002000	ESCUADRA AMARRE TAPA EDESA	ATTACHMENT BRACKET COVER	2			
	Z200550000	ASA PUERTA COMPLETA	COMPLETE DOOR HANDLE	1			
	Z454501000	EMBELLECEDOR ADHESIV. VGL10	ADHESIVE TRIM VGL10	1			
	Z448005000	FRENTE EXTRAIBLE EDESA	EXTRACTABLE FRONT EDESA	1			
	Z468008000	BASE EXTR. LV-1200-1500-2100	EXTR. BASE LV-1200-1500-2100	1			
	Z448007000	TAPA COMPLETA LV-2100	COMPLETE COVER LV-2100	1			
	Z448009000	ESCUADRA AMARRE JUNTA TAPA	FASTENING BRACKET SEAL COV	1			
	Z448010000	PERFIL TAPA LV-2100 EDESA	COVER PROFILE LV-2100 EDESA	1			
	Z468025000	DISTANCIA. INTERRUPTOR RELE	DISTANCE RELAY SWITCH	1			
	Z218036000	SOPORTE COMPONENTES	COMPONENT SUPPORT	1			
	T302829000	DISTANCIADOR COMPONENTES	SPACER COMPONENTS	2			
	Z393005000	TERMOSTATO CALDERIN	WASH DRUM THERMOSTAT	1			
	Z748008000	SOPORTE BULBO TERMOSTATO	THERMOSTAT BULB SUPPORT	1			
	Z218011000	PROGRAMADOR GICAR TECLADO	KEYPAD GICAR PROGRAMMER	1			
	Z218012000	PROGRAMADOR GICAR C.RELES	GICAR PROGRAMMER WITH REL	1			
	Z218030000	INTERRUPTOR RELE C.I.	C.I. RELAY SWITCH	1			
	Z458002000	ESQUEMA TEORICO LV 2100-B	THEORETICAL DIAGRAM LV 2100	1			
	Z448017000	PLANO MONTAJE LV EDESA	LV EDESA ASSEMBLY PLAN	1			
	Z218013000	CABLEADO GICAR	WIRING GICAR	1			
	Z448016000	INSTALACION ELEC.LAVAVASOS ED	GLASS WASHER ELEC. INSTALL	1			
	Z283022000	CABLE TIERRA M.BOMBA	EARTH WIRE M. PUMP	1			
	Z454502000	FOLLETO INSTRUCCIONES	INSTRUCTION LEAFLET.	1			

LVR - 10; LVC - 12; A-9; LVC-12 T; CLV-12-C; DBY-1000;MLV-35; ASC-12

1N ~ 240V. 50 Hz.
2 ~ 220V. 50/60 Hz.

3N ~ 380 - 415 V.

Зип Общепит

vsezip.ru

7(812)987-08-81

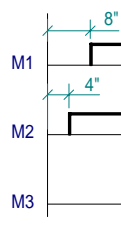
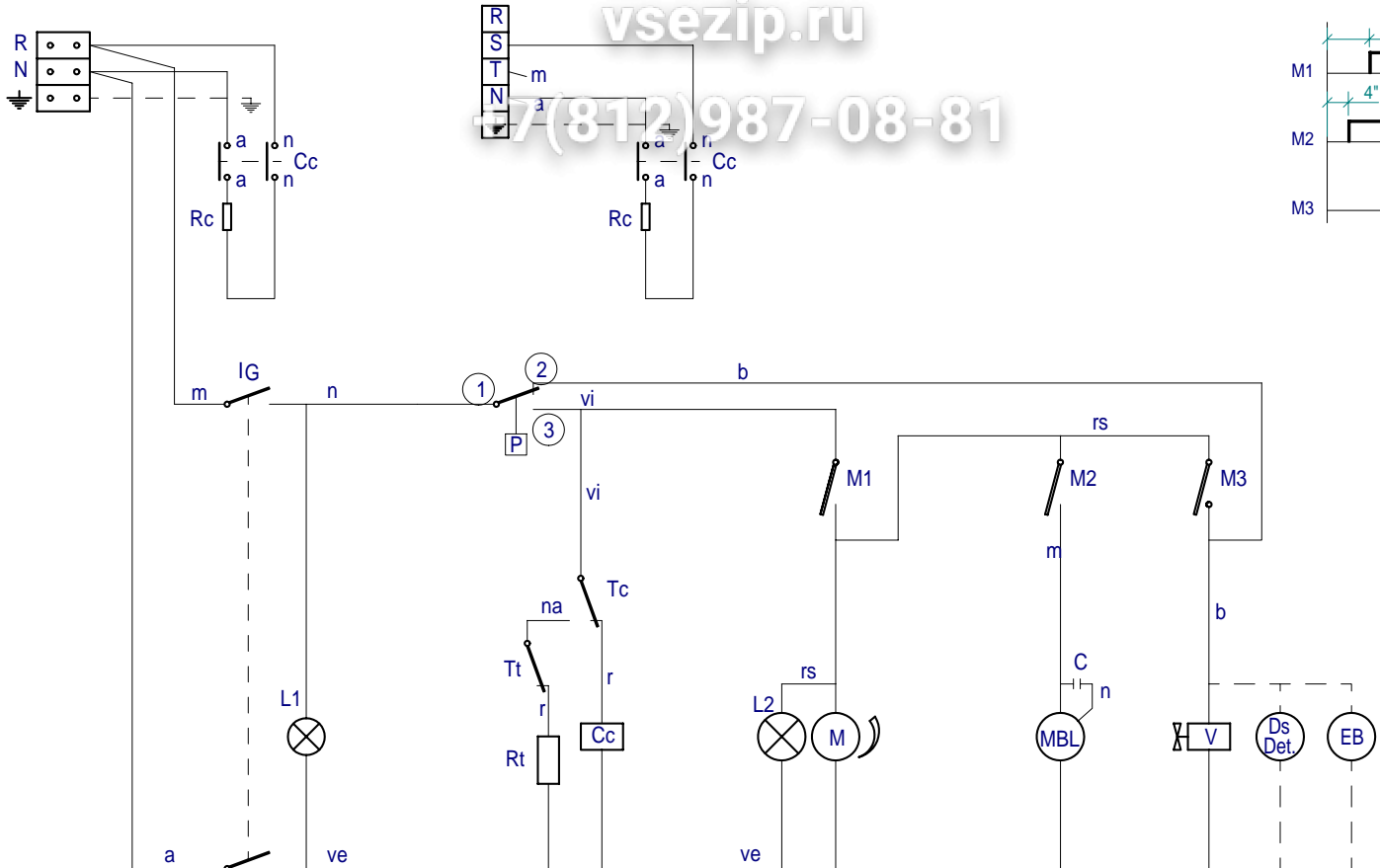

- IG = Interruptor General
- L1 = Lámpara de marcha
- P = Presostato
- Tc = Termostato calderín
- Cc = Contactor calderín
- Rc = Resistencia calderín
- Ds Det = Dosificador de detergente (opcional)
- EB = Electrobomba de presión (Opcional)
- Tt = Termostato tanque
- Rt = Resistencia tanque

- M = Motor programador
- M1 = Micro programador marcha
- M2 = Micro programador lavado
- M3 = Micro programador aclarado
- L2 = Lámpara de ciclo
- MBL = Motobomba lavado
- C = Condensador de motobomba
- V = Válvula de llenado y aclarado

Esquema teorico adhesivo		
Nº	Pieza	
Nº	Modificación	
①	Introducir denominación LVC-12T	
②	Introducir modelo CORECO	
③	DBY-1000 bertsioa sartu	
④	MLV-35 bertsioa sartu	
⑤	ASC-12 bertsioa sartu	
	Firma	Fecha
Dibujado	S. N.	7-10-97
Proyectado		
Comprobado		
Escala		
Plano hau ez daiteke erabili ez berritza gure		

1N ~ 240V. 50 Hz.
2 ~ 220V. 50/60 Hz.

3N ~ 380 / 415 V

- LVR - 14 ; LVC - 15
- LVR - 20 ; LVC - 21
- A-15 ; A-21 ; KM - 21
- FV - 26R ; FV - 26C
- GX - 5R ; GX - 5C
- FV - 20R ; FV - 20C
- GX - 4R ; GX - 4C
- ④ CLV-15-C ; CLV-21-C
- ⑤ MLV-35-S ; MLV-40
- ⑥ ASC-21

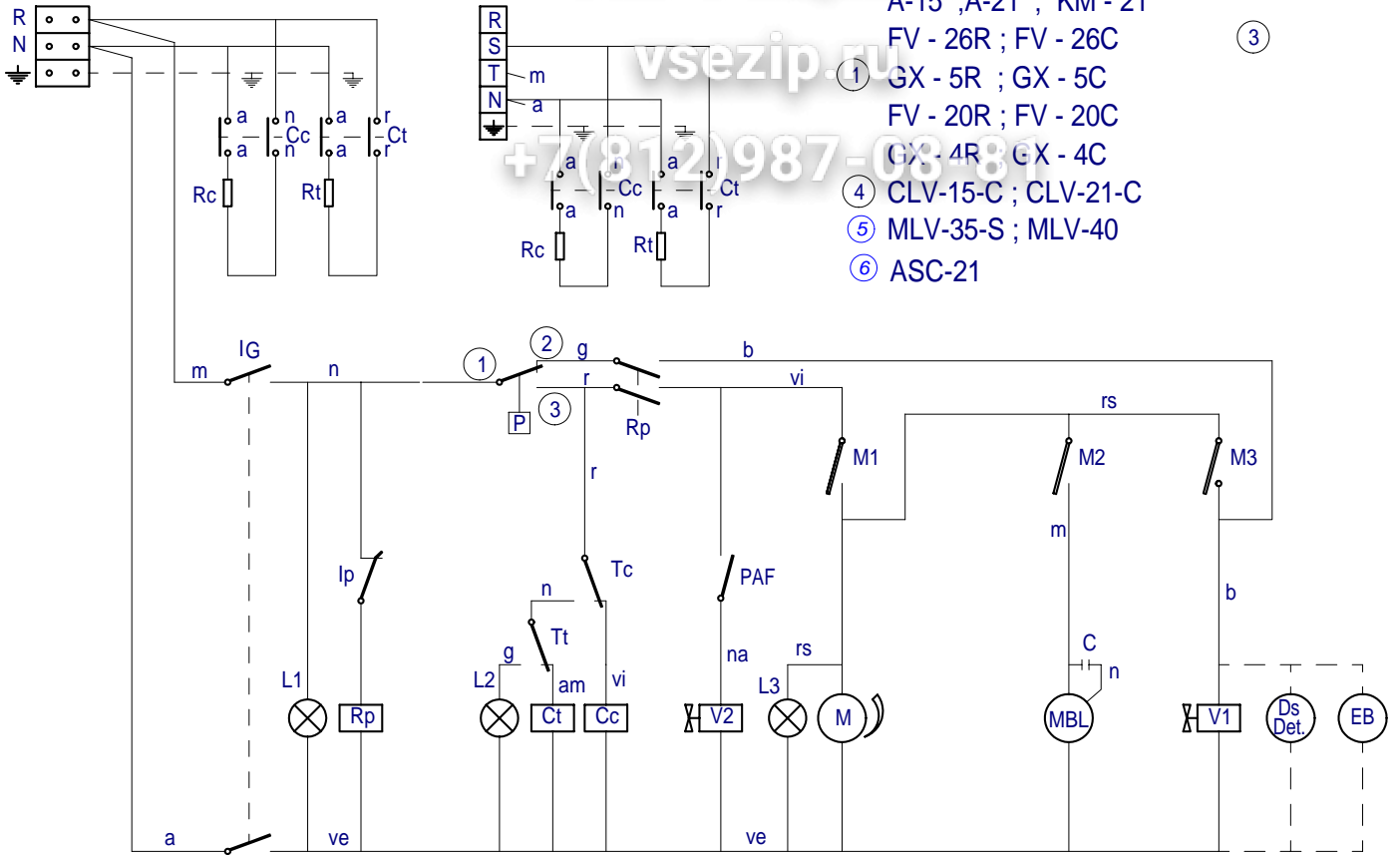

- IG= Interruptor General
- L1 = Lampara de marcha
- Ip = Micro de puerta
- Rp = Relé puerta
- P = Presostato
- Tc = Termostato calderin
- Tt = Termostato tanque
- Cc = Contactor calderin
- Ct = Contactor tanque
- L2 = Lampara máquina preparada
- Rc = Resistencia calderin
- Rt = Resistencia tanque
- Ds Det = Dosificador de detergente (opcional)

- M = Motor programador
- M1 = Micro programador marcha
- M2 = Micro programador lavado
- M3 = Micro programador aclarado
- L3 = Lámpara de ciclo
- MBL= Motobomba lavado
- C = Condensador de motobomba
- V1 = Válvula de llenado y aclarado
- V2 = Válvula de aclarado en frío
- EB = Electrobomba de presión (Opcional)
- PAF= Pulsador aclarado en frío

Esquema teorico adhesivo		
Nº	Pieza	
Nº	Modificacion	
⑥	ASC-21 ASCASO modelo a sartztea	
②	Modificar color en Tt	
③	Introducir versión KM - 21	
④	Introducir modelos CORECO	
⑤	MOVILFRIT modelo a sartztea	
	Firma	Fecha
Dibujado	S. N.	28-9-95
Proyectado		
Comprobado		
Escala		
Plano hau ez daiteke erabili ez berizta gure		

1N ~ 240V. 50 Hz.
2 ~ 220V. 50/60 Hz.

3N ~ 380 - 415 V.

LVR-14 D; LVC-15 D

LVR-20 D; LVC-21 D

① CLV-15-CD; CLV-21-CD

② MLV-35-D ; MLV-40-D

Зип Общественное
vsezip.ru

+7(812)987-08-81

	1 1a	2 2a	3 3a	4 4a	5 5a	6 6a	7 7a	8 8a
	X		X	X				X
0								
120	X		X		X	X	X	X
0	X		X	X	X	X	X	X

IG

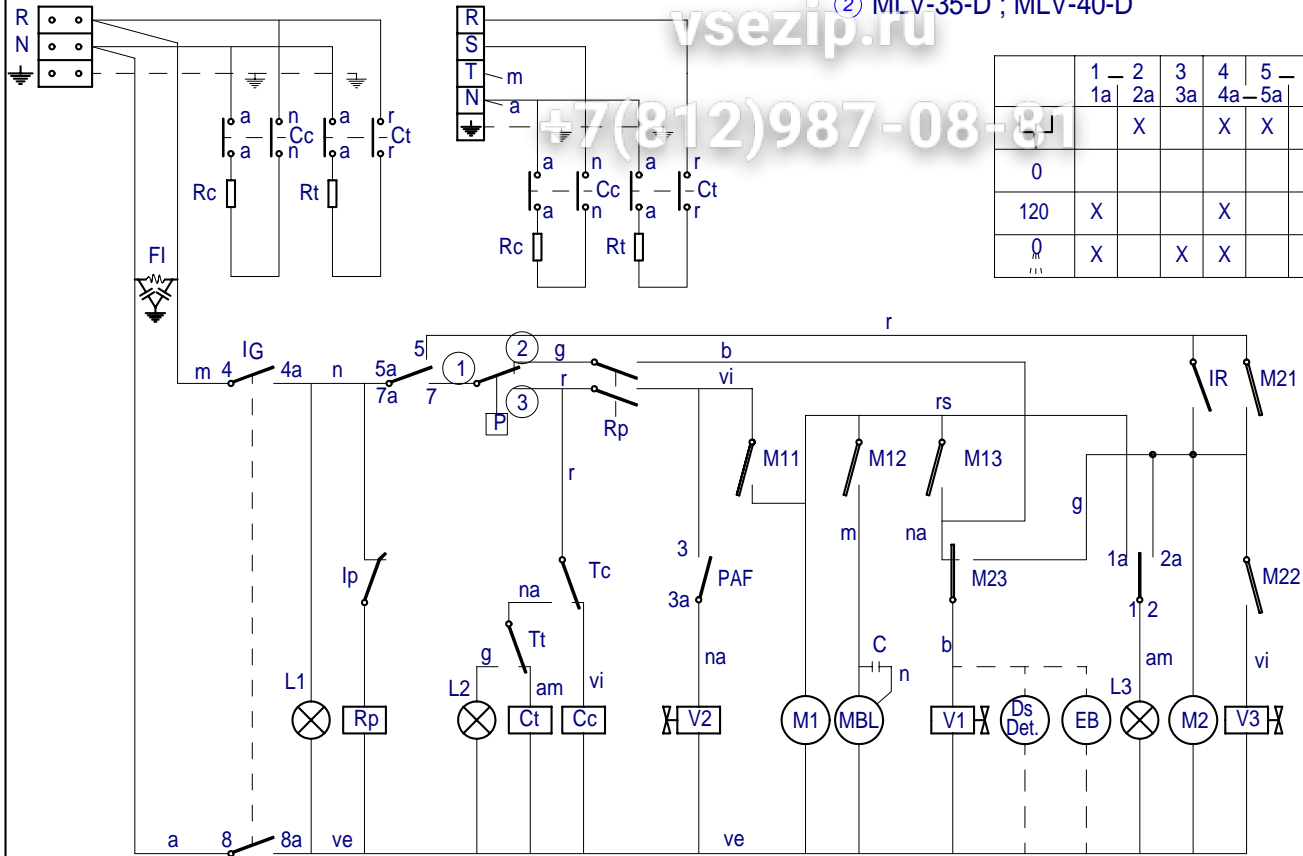

CODIGO
r = rojo-rojo
m = marro
g = gris-gr
n = negro-
a = azul-bl
b = blanco
vi = violeta
am = ama
na = naran
rs = rosa-r
ve = verde
am/ve = ar

- I = Interruptor General
- L1 = Lampara de marcha
- Ip = Micro de puerta
- Rp = Relé puerta
- P = Presostato
- Tc = Termostato calderin
- Tt = Termostato tanque
- Cc = Contactor calderin
- Ct = Contactor tanque
- L2 = Lampara máquina preparada
- Rc = Resistencia calderin
- Rt = Resistencia tanque
- Ds Det = Dosificador de detergente (opcional)
- V3 = Electroválvula regeneración
- IR = Pulsador regeneración

- M1 = Motor programador
- M11 = Micro programador marcha
- M12 = Micro programador lavado
- M13 = Micro programador aclarado
- M2 = Motor programador
- M21 = Micro programador marcha regeneración
- M22 = Micro programador regeneración por depósito
- M23 = Micro programador regeneración por dosificación
- MBL = Motobomba lavado
- C = Condensador de motobomba
- V1 = Válvula de llenado y aclarado
- V2 = Válvula de aclarado en frio
- EB = Electrobomba de presión (Opcional)
- PAF = Pulsador aclarado en frio

Esquema teorico adhesivo		
Nº	Pieza	
Nº	Modificación	
①	Introducir modelo CORECO	
②	MOVILFRIT modeloak sartu	
Firma		Fecha
Dibujado	S. N.	6-2-96
Proyectado		
Comprobado		
Escala		
Plano hau ez daitelke erabili ez berizta gure		

1N ~ 240V. 50 Hz.
2 ~ 220V. 50/60 Hz.

3N ~ 380 - 415 V.

Zip Obzert
vsezip.ru
+7(812)987-03-81
LVC - 21 B ; LVC-21C ; KM - 21 B
CLV - 21 - CB
MLV - 40 - B, LAB-2100 B

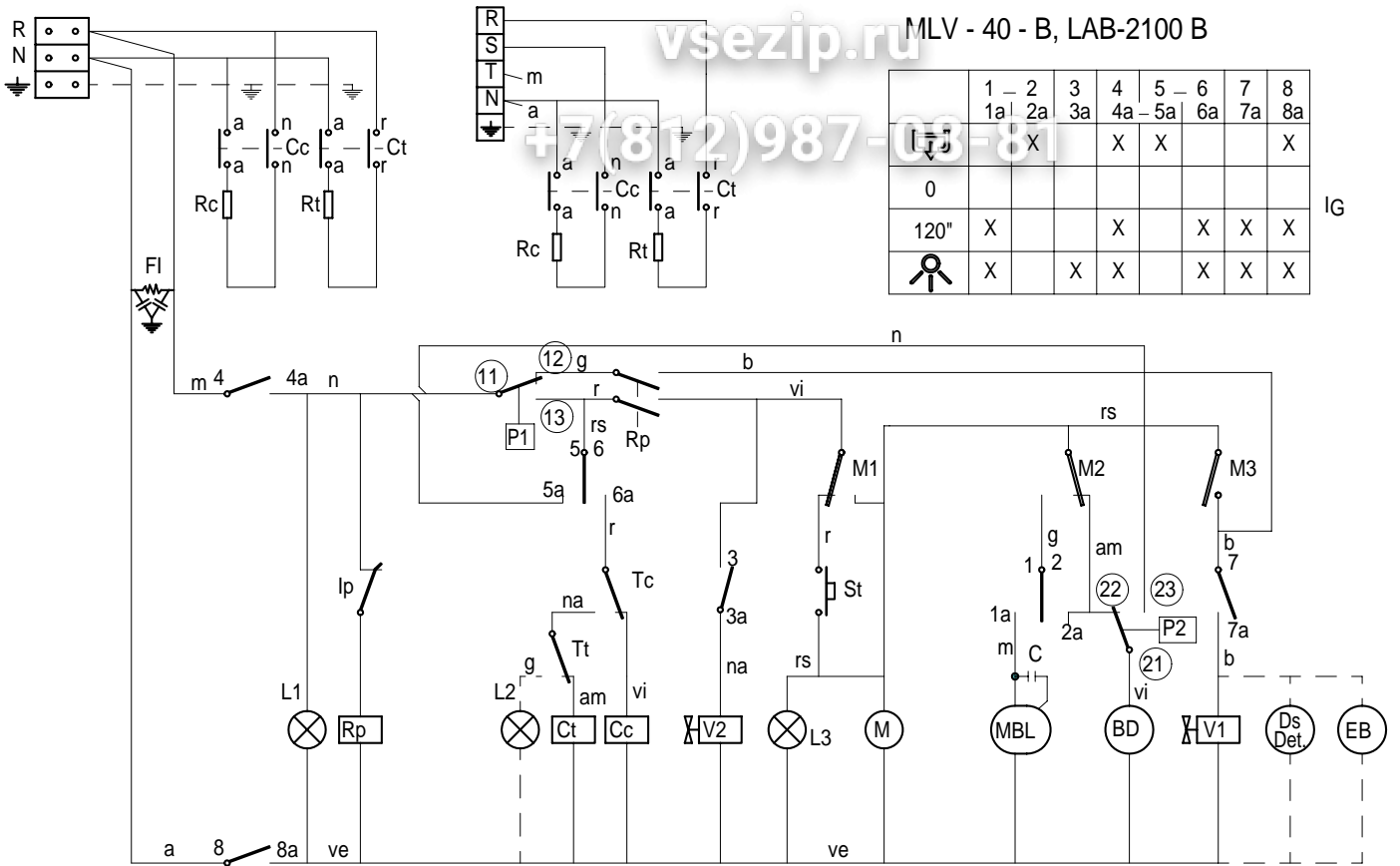

	1 - 2 1a 2a	3 3a	4 4a	5 - 6 5a 6a	7 7a	8 8a
I _g	X		X	X		X
0						
120"	X		X	X	X	X
	X	X	X	X	X	X

I_g = Interruptor General
L1 = Lampara de marcha
Ip = Micro de puerta
Rp = Relé puerta
P1 = Presostato
Tc = Termostato calderin
Tt = Termostato tanque
Cc = Contactor calderin
Ct = Contactor tanque
L2 = Lampara máquina preparada
Rc = Resistencia calderin
St = Pulsador de marcha
FI = Filtro de interferencias
BD = Bomba de Desagüe

Rt = Resistencia tanque
M = Motor programador
M1 = Micro programador marcha
M2 = Micro programador lavado
M3 = Micro programador aclarado
L3 = Lámpara de ciclo
MBL = Motobomba lavado
C = Condensador de motobomba
V1 = Válvula de llenado y aclarado
Ds Det = Dosificador de detergente (opcional)
P2 = Presostato de seguridad
EB = Electrobomba de presión (Opcional)
V2 = Válvula aclarado en frio

Esquema teorico adhesivo		
Nº	Pieza	
Nº	Modificacion	
①	Introducir modelo CORECO	
②	MOVILFRIT modeloa sartzea	
③	LVC-21C modeloa sartu	
	Firma	Fecha
Dibujado	J.M.P.	20-10-99
Proyectado		
Comprobado		
Escala		

Plano hau ez daitelke erabili ez berizta gure

	1 - 1a	2 - 2a	3 - 3a	4 - 4a	5 - 5a	6 - 6a	7 - 7a	8 - 8a
0		X		X	X			X
120°	X			X		X	X	X
0	X		X	X		X	X	X

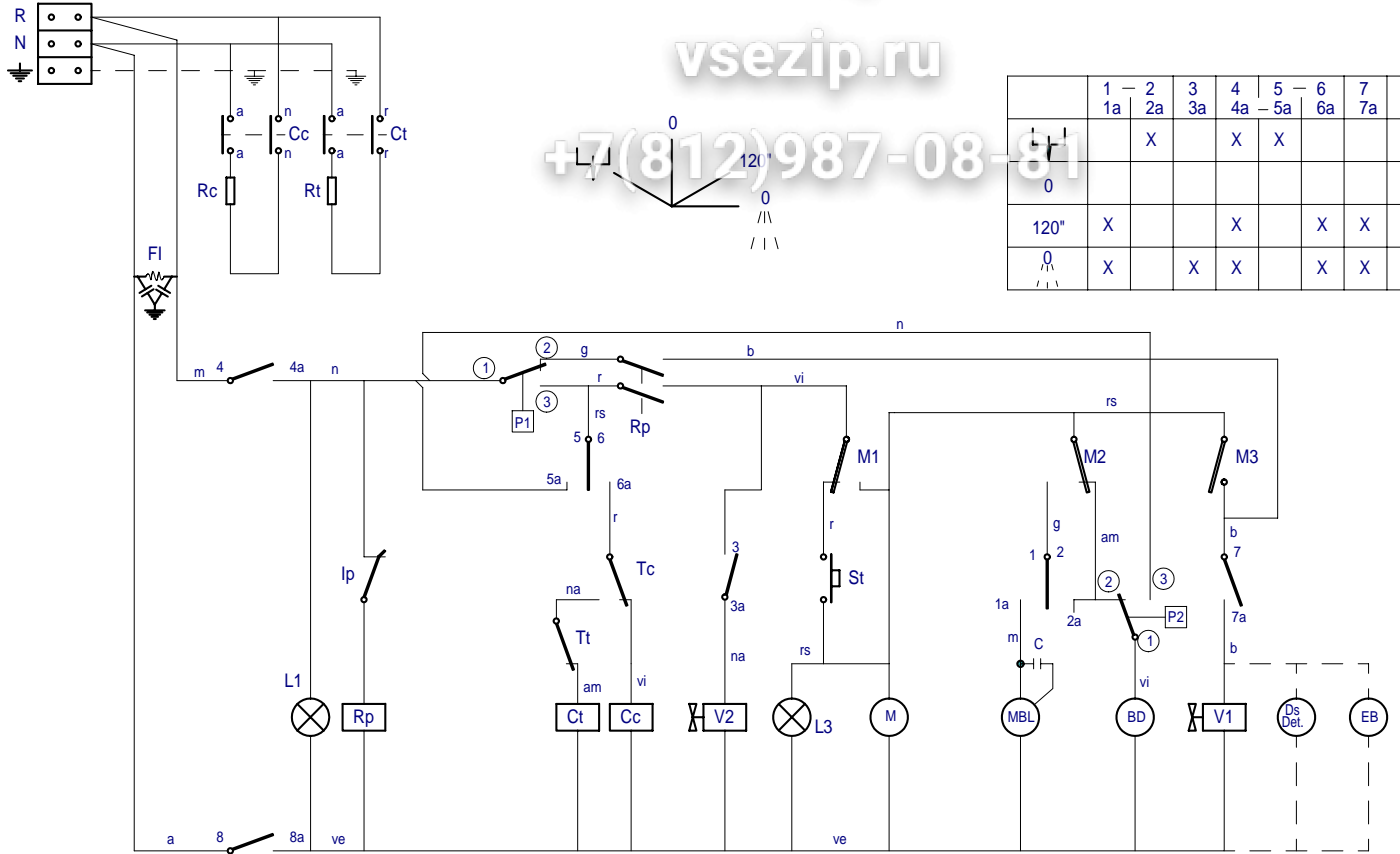

I_G = General switch
 L1 = On lamp
 Ip = Door micro
 Rp = Door relay
 P1 = Pressure switch
 Tc = Drum thermostat
 Tt = Tank thermostat
 Cc = Drum contactor
 Ct = Tank contactor
 L2 = Machine ready light
 Rc = Drum heating element
 St = Start button
 FI = Interferences filter
 BD = Drain pump

Interrupteur general
 Témoins de marche
 Micro de porte
 Relais de porte
 Presostat
 Thermostat du surchauffeur
 Thermostat de cuve
 Contacteur du surchauffeur
 Contacteur de cuve
 Témoins de machine préparée
 Resistance du surchauffeur
 Resistencia calderin
 Bouton de marche
 Filtre d'interferences
 Pompe de vidange

Interruptor General
 Lampara de marcha
 Micro de puerta
 Relé puerta
 Presostato
 Termostato calderin
 Termostato tanque
 Contactador calderin
 Contactador tanque
 Lampara máquina preparada
 Resistencia calderin
 Pulsador de marcha
 Filtro de interferencias
 Bomba de Desagüe

Rt = Tank heating element
 M = Motor programmer
 M1 = Micro programmer on
 M2 = Micro programmer wash
 M3 = Micro programmer rinse
 L3 = Cycle light
 MBL = Motor pump wash
 C = Motor pump condenser
 V1 = Filling and rinsing valve
 V2 = Cold rinsing valve
 Ds Det = Detergent dispenser (Optional)
 P2 = Safety pressure switch
 EB = Electric pressure pump (Optional)

Resistancia
 Moteur d
 Micro du
 Micro du
 Micro du
 Témoins d
 Motopompe
 Condens
 Valve de
 Valve de
 Doseur d
 Presostat
 Electropo

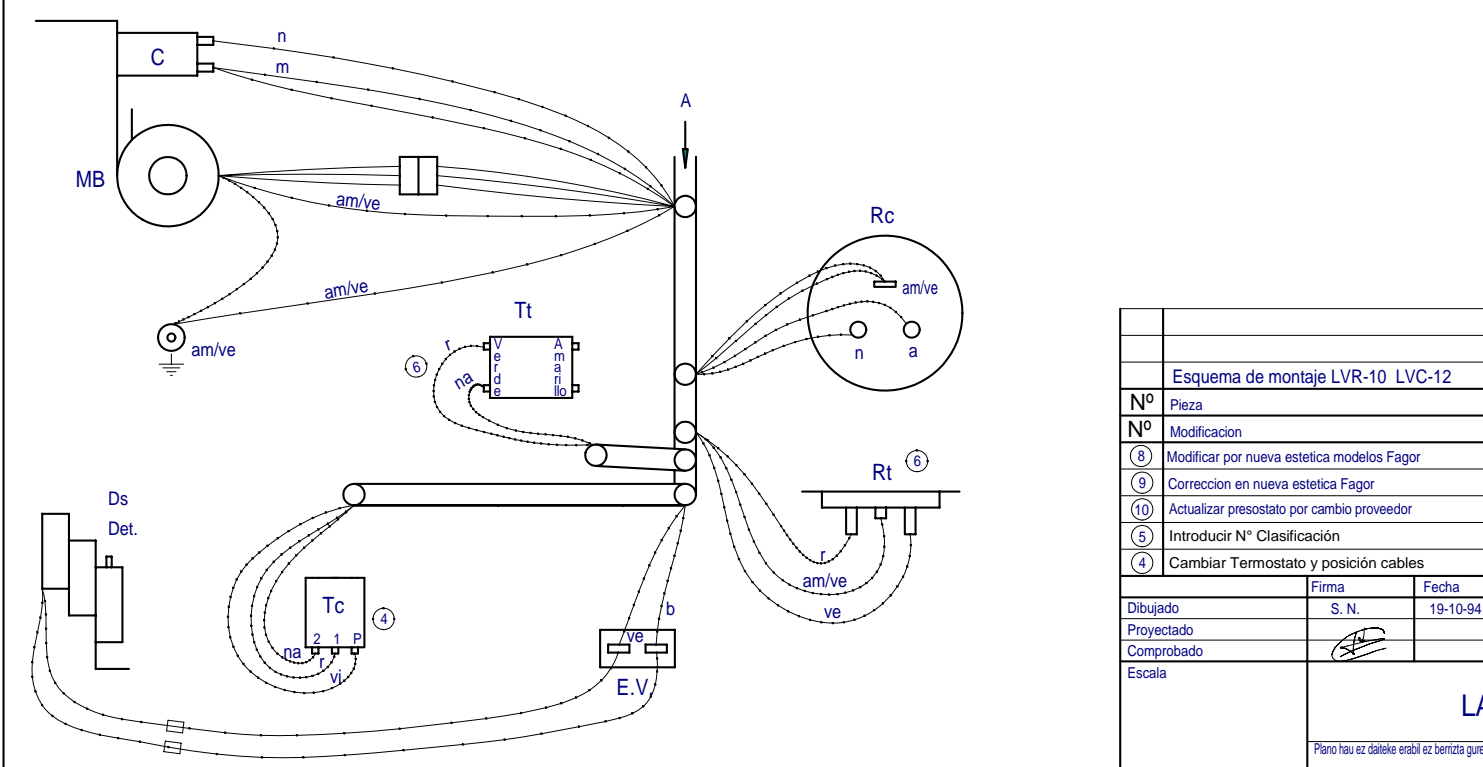
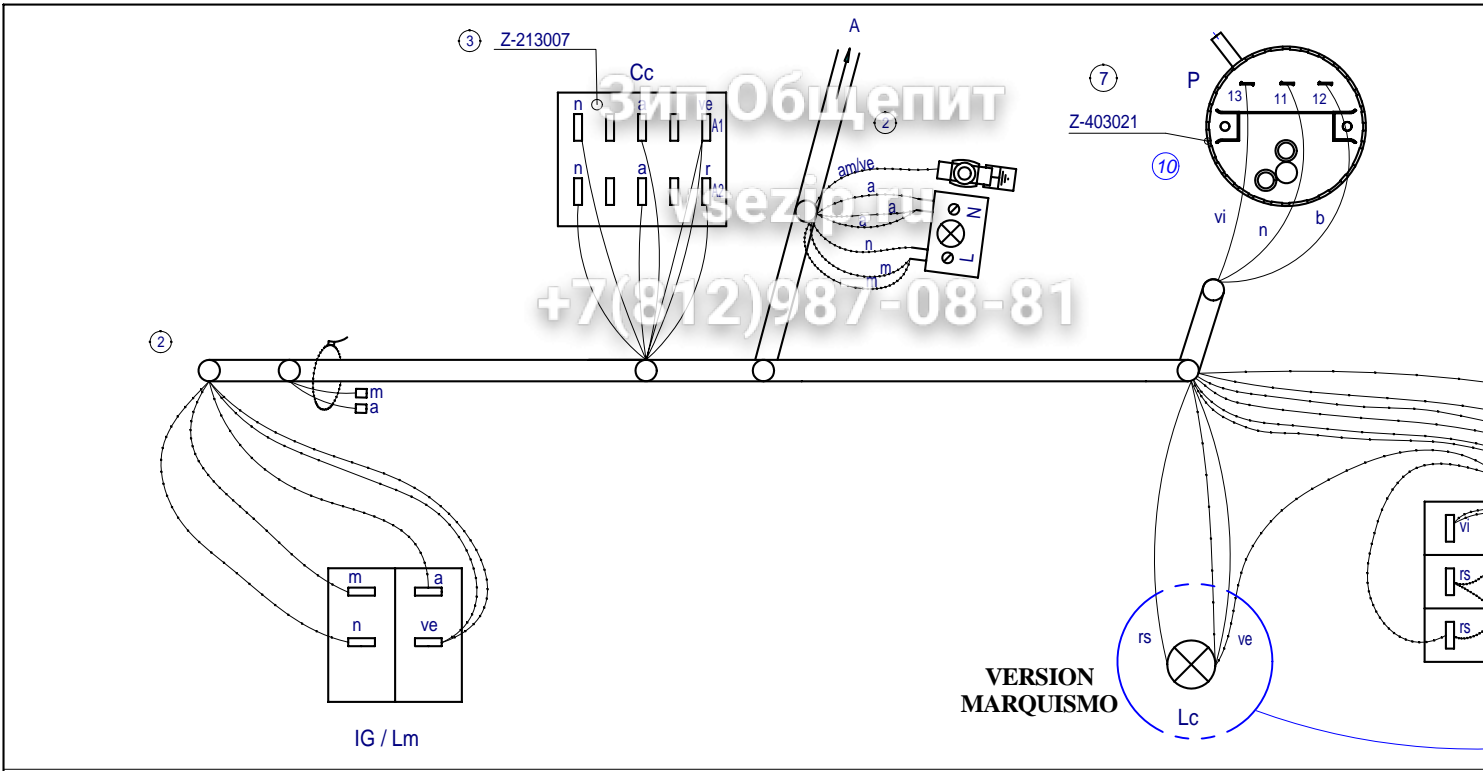

Esquema de montaje LVR-10 LVC-12		
Nº	Pieza	
Nº	Modificación	
⑧	Modificar por nueva estética modelos Fagor	
⑨	Corrección en nueva estética Fagor	
⑩	Actualizar presostato por cambio proveedor	
⑤	Introducir N° Clasificación	
④	Cambiar Termostato y posición cables	
	Firma	Fecha
Dibujado	S. N.	19-10-94
Proyectado		
Comprobado		
Escala		
Plano hau ez daiteke erabili ez berizta gure		

Зип Общепит

vsezip.ru

+7 (812) 987-08-81

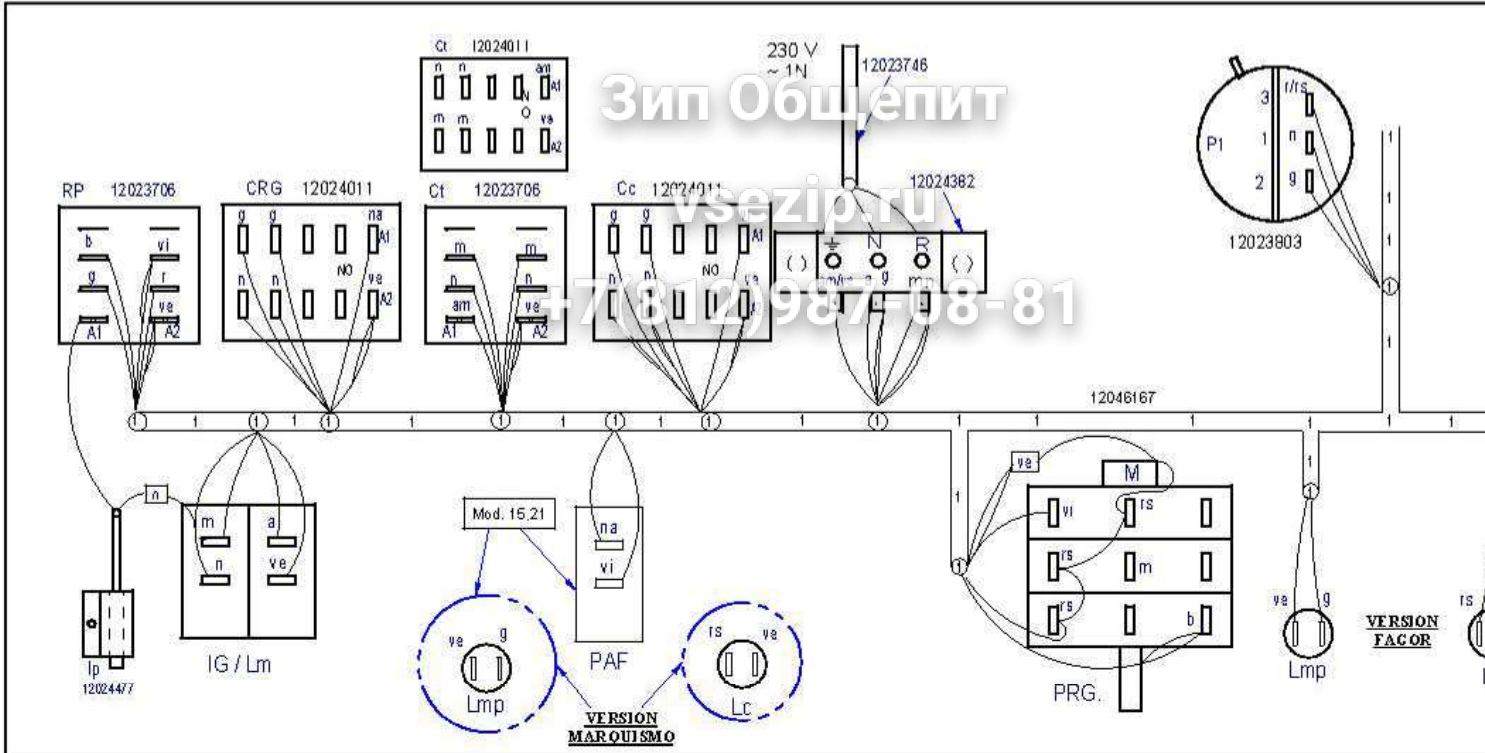

Nota: Todos los cables hembra que quedan sin conectar se les colocaran una funda macho Q-578006

ESQUEMA ADHESIVO 12022139
LEYENDA 12022100
INDICADOR DE COMPONENTES Z713034000

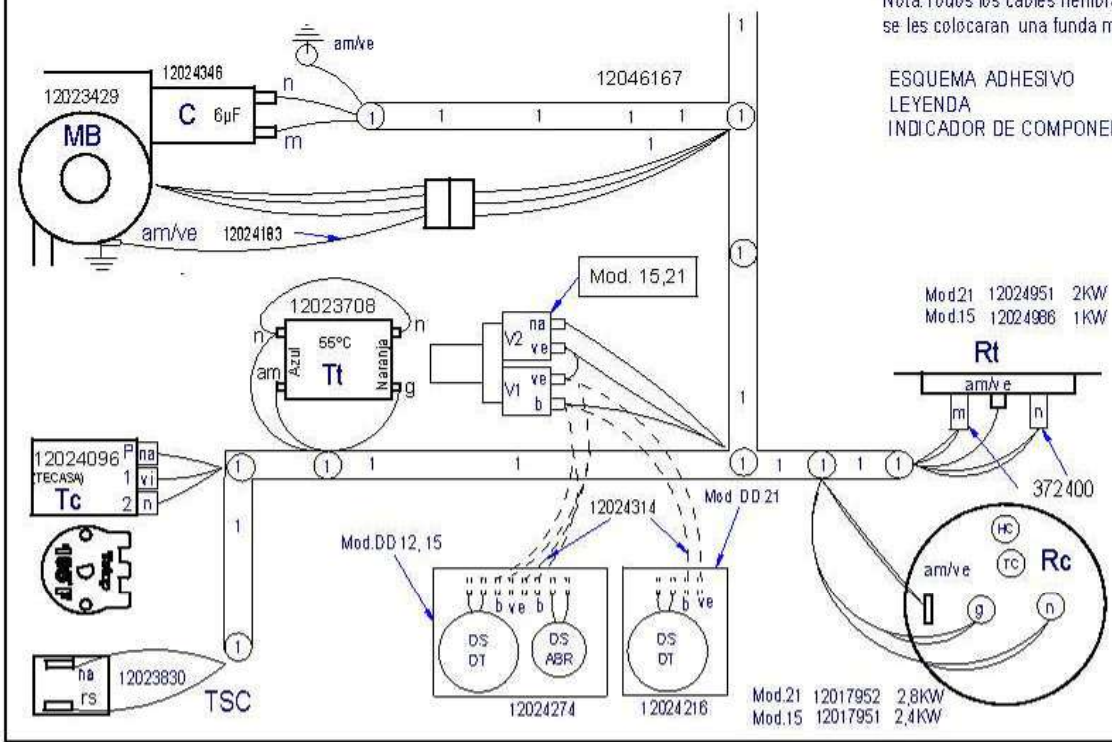

- Plano Montaje LVC, 21, 15, 12											
Nº		TITULO									
GENERAL TOLERANCES ISO 2768-1											
h	3mm	h05	h10	h15	h20			h30	h40	h50	h60
	3-12mm	h05	h10	h15	h20	h30	h40	h50	h60	h70	h80
	12-40mm	h05	h10	h15	h20	h30	h40	h50	h60	h70	h80
	40-125mm	h05	h10	h15	h20	h30	h40	h50	h60	h70	h80
	125-500mm	h05	h10	h15	h20	h30	h40	h50	h60	h70	h80
LAVAVASOS											
12046369		REVISION									

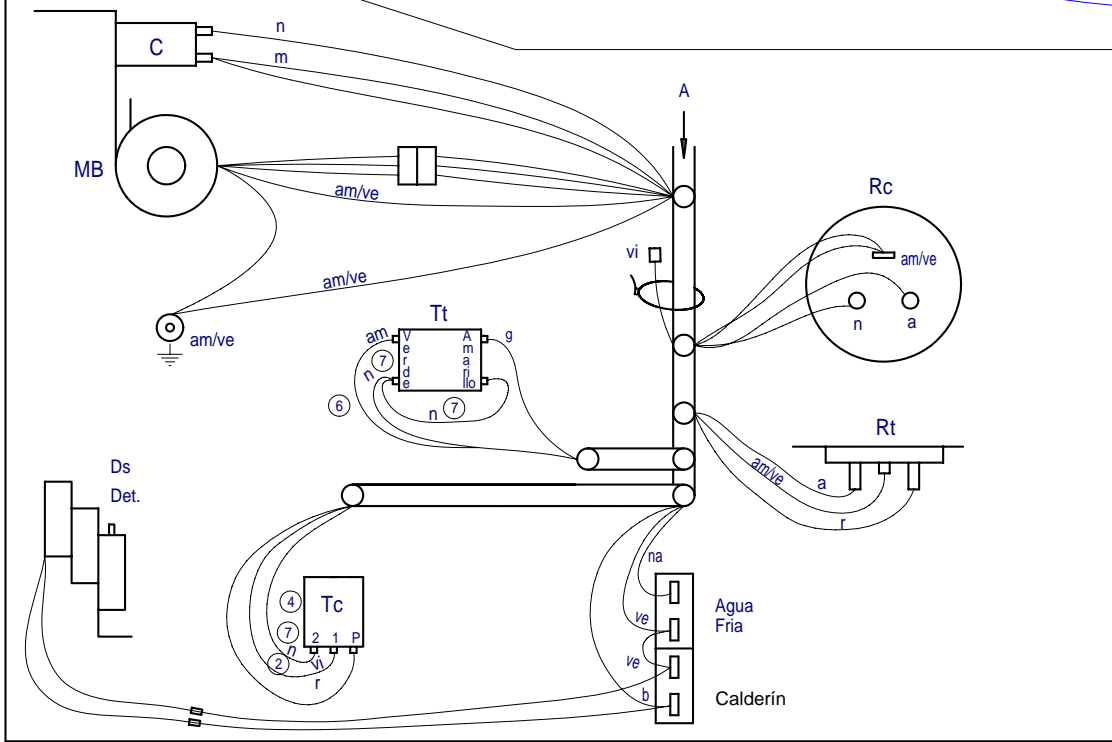
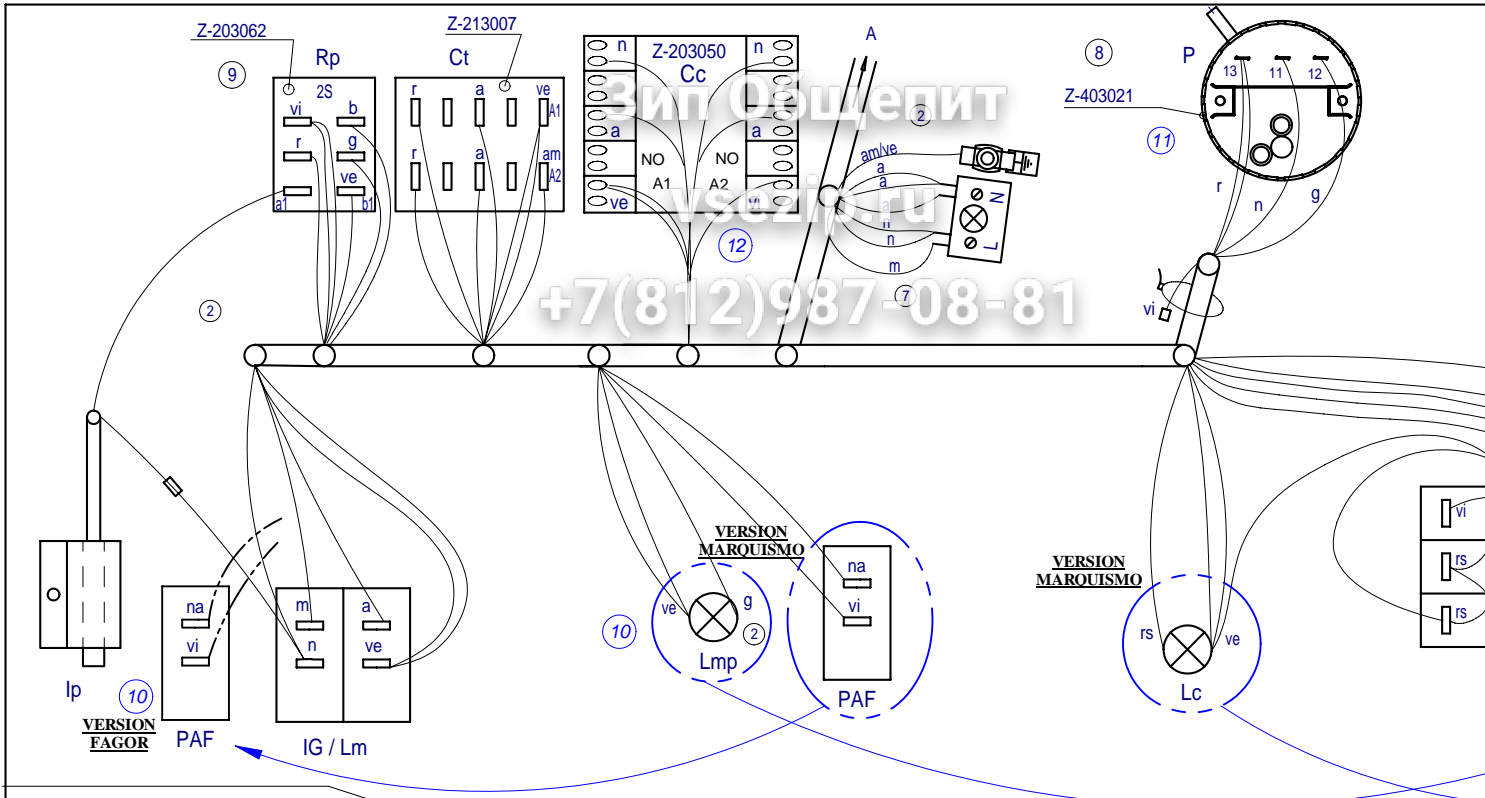

Esquema de montaje LVR-14; LVC-15; LVI		
Nº	Pieza	
Nº	Modificacion	
7	Pasar de color Naranja a Negro en Tc y Tt	
8	Introducir presostato Z-403021	
9	Sustituir relé Z-203018 por Z-203062, cambiar colores	
10	Correccion nueva estetica modelos Fagor	
11	Actualizar presostato por cambio proveedor	
12	Aldatu kalderineko kontaktorea Z213007 --> Z203050	
	Firma	Fecha
Dibujado	S. N.	19-10-94
Proyectado		
Comprobado		
Escala		

Plano hau ez daiteke erabili ez berziza gure

Зип Общепит
 vsezip.ru
 +7(812)987-08-51

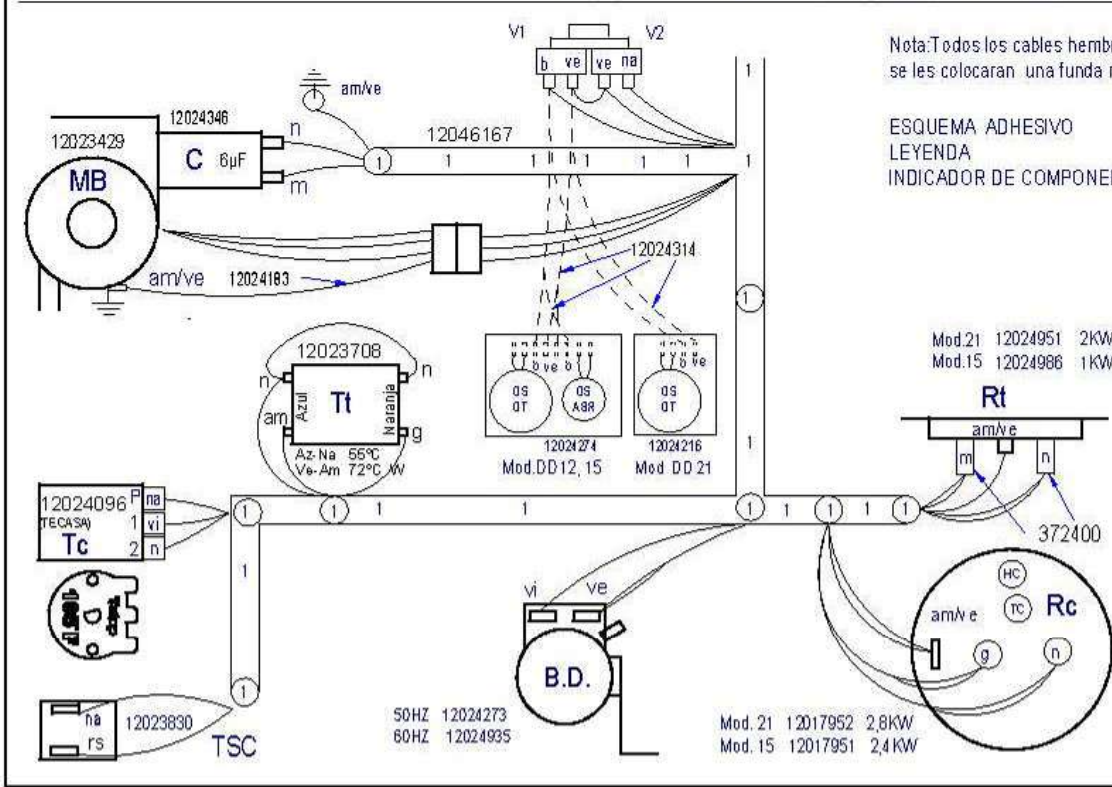
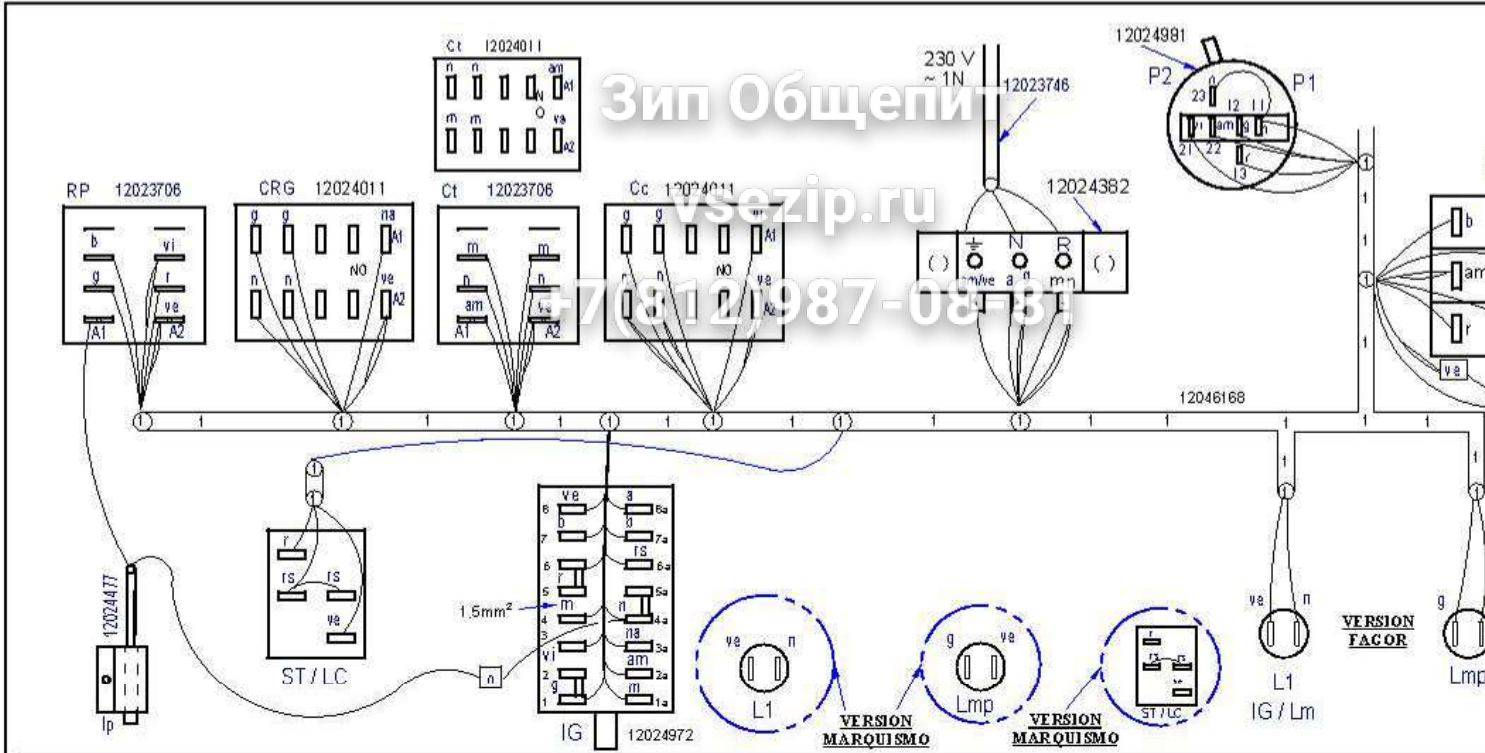

Nota: Todos los cables hembra que queden sin conectar se les colocaran una funda macho Q-578006

ESQUEMA ADHESIVO 12022114
 LEYENDA 12022100
 INDICADOR DE COMPONENTES Z713034000

- Plano Montaje LVC, 21, 15, B					
Nº		TITLE			
GENERAL TOLERANCES			ISO 2768-1		
M	±0.2mm	M0.05	M0.10	M0.15	V0.2
	±0.3mm	M0.05	M0.10	M0.20	V0.3
	±0.5mm	M0.10	M0.20	M0.30	V0.5
	±0.7mm	M0.15	M0.30	M0.50	V0.7
L	±0.2mm	L0.05	L0.10	L0.15	L0.2
	±0.3mm	L0.05	L0.10	L0.20	L0.3
	±0.5mm	L0.10	L0.20	L0.30	L0.5
	±0.7mm	L0.15	L0.30	L0.50	L0.7
LAVAVASOS					
12046409		REVISION			

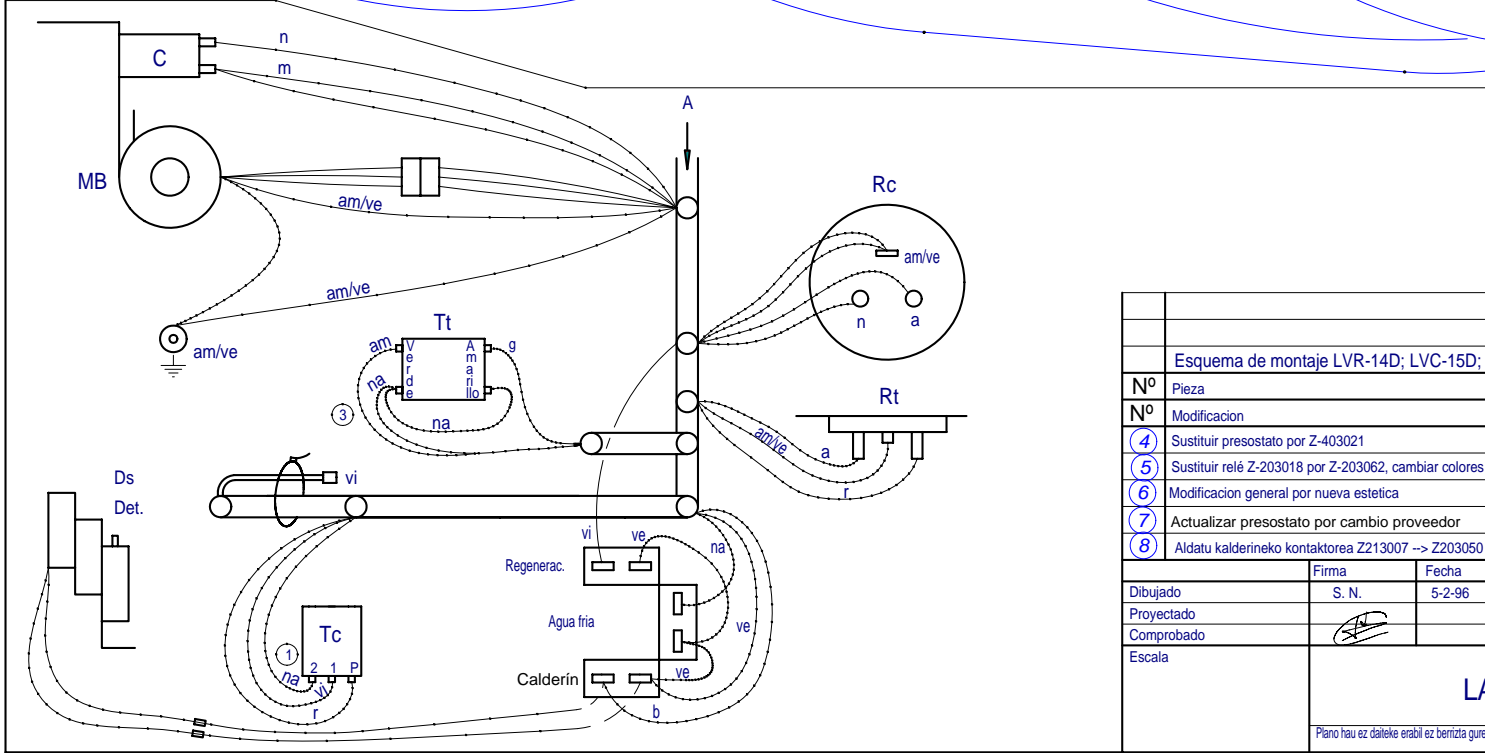
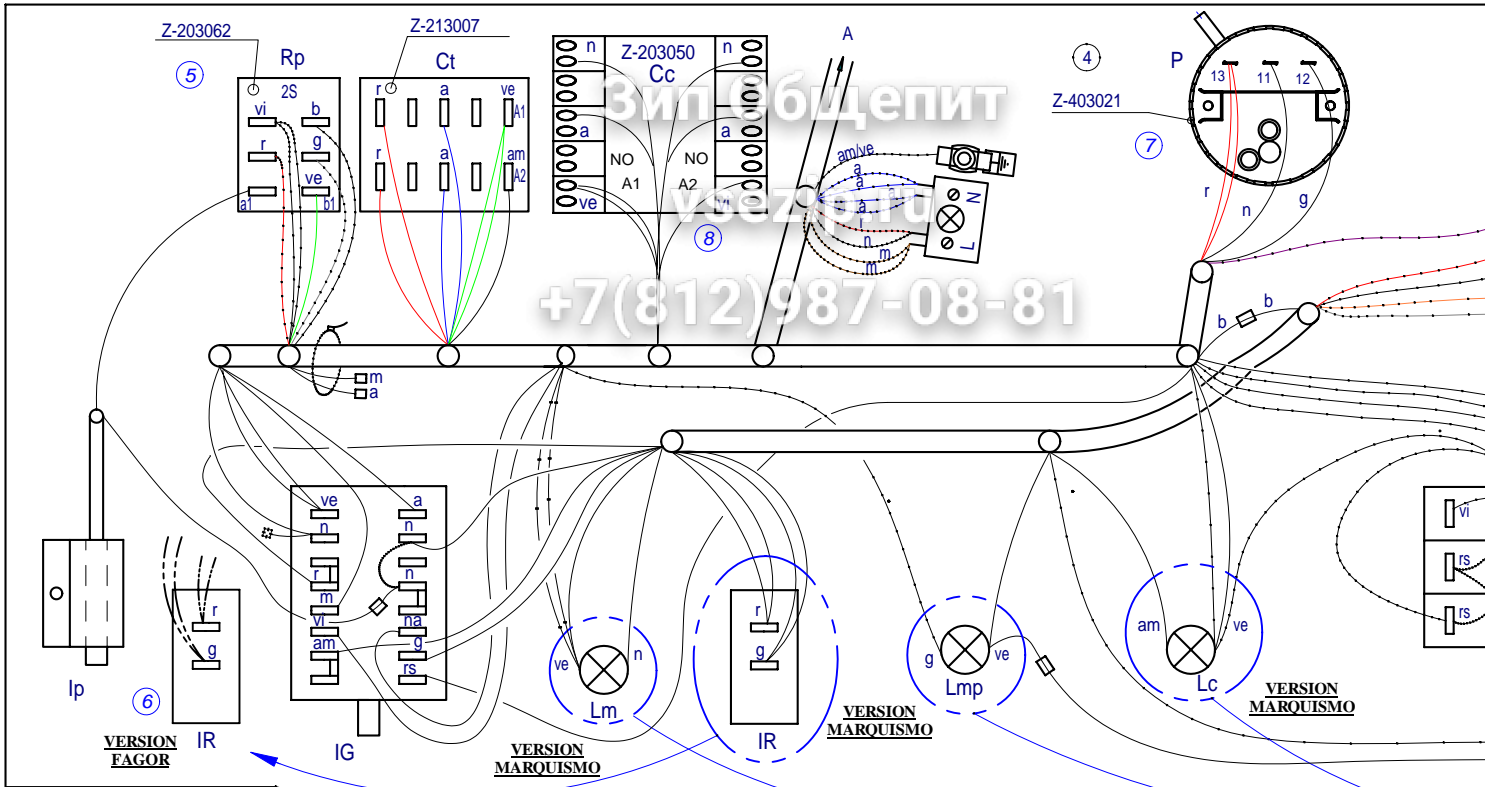

Esquema de montaje LVR-14D; LVC-15D;		
Nº	Pieza	
Nº	Modificación	
④	Sustituir presostato por Z-403021	
⑤	Sustituir relé Z-203018 por Z-203062, cambiar colores	
⑥	Modificación general por nueva estética	
⑦	Actualizar presostato por cambio proveedor	
⑧	Aldatu kalderineko kontaktorea Z213007 --> Z203050	
	Firma	Fecha
Dibujado	S. N.	5-2-96
Proyectado		
Comprobado		
Escala		
Plano hau ez daitelke erabili ez berizta gure		

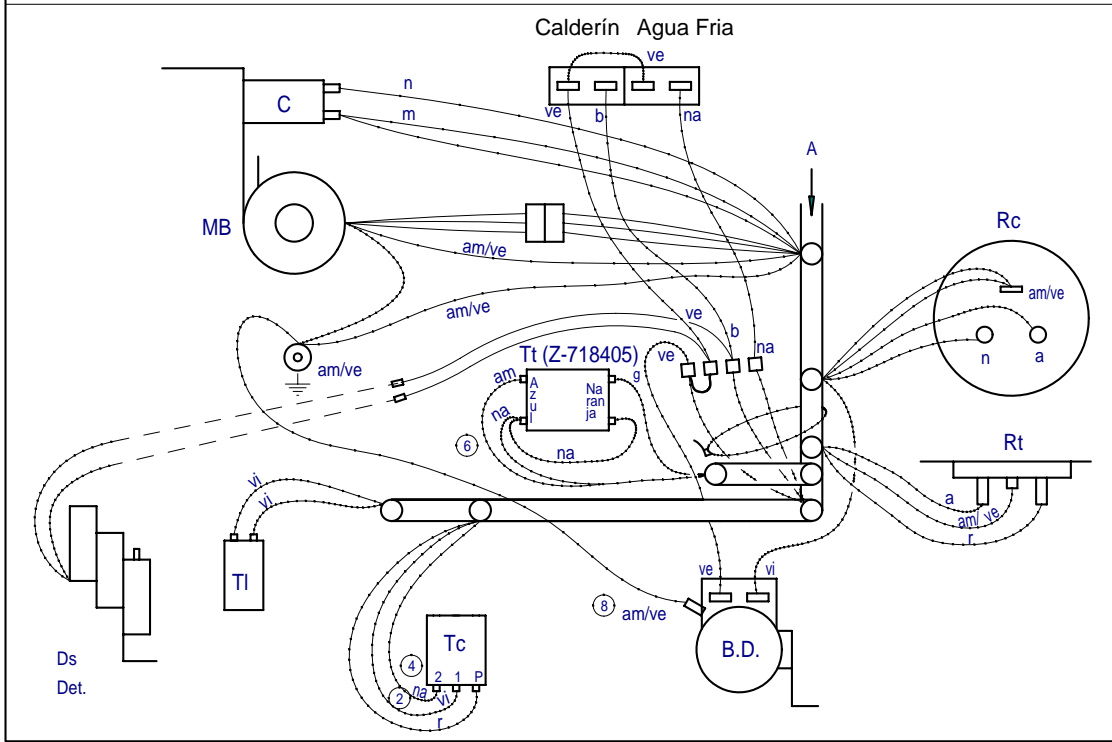
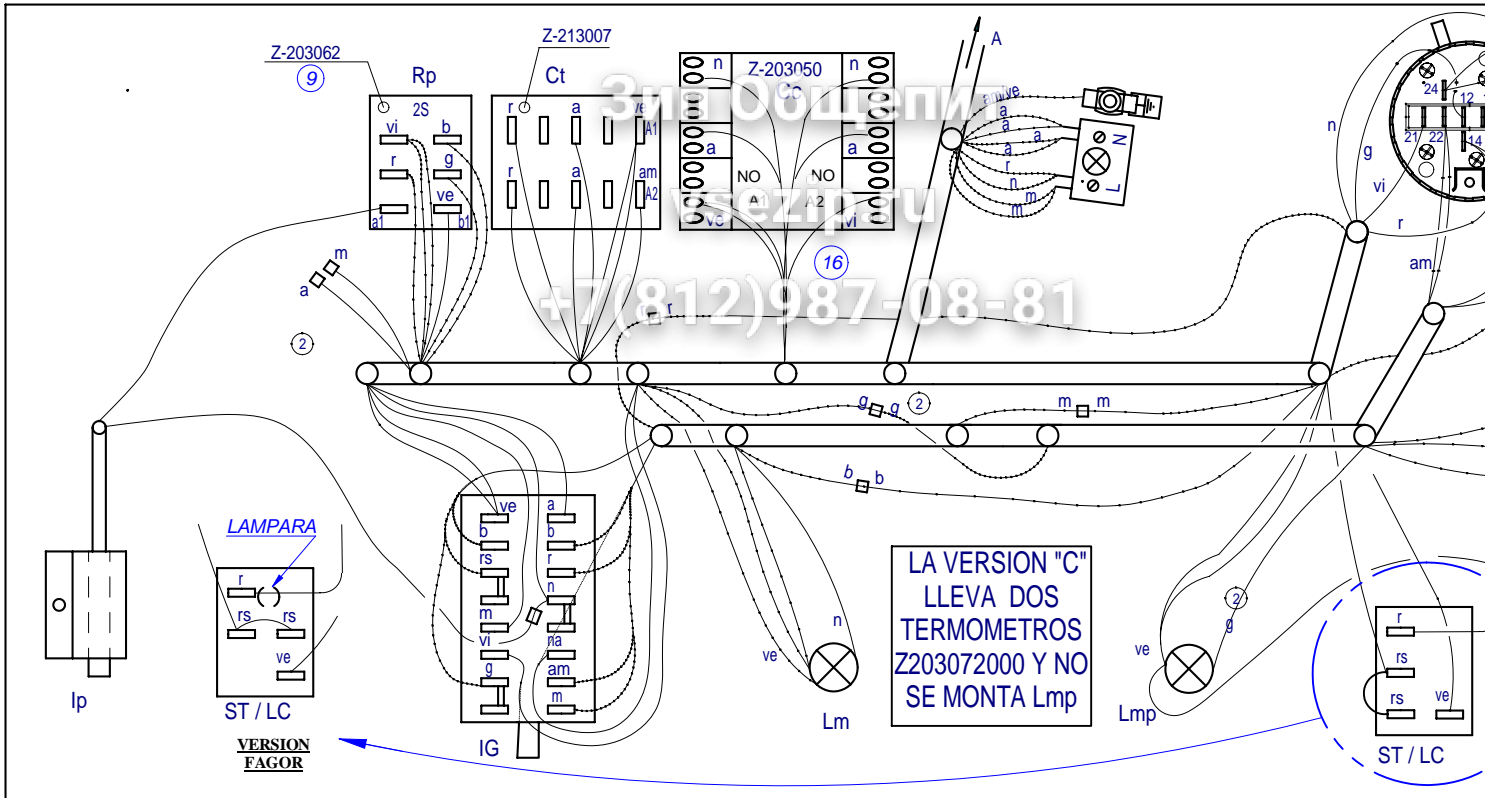

Esquema de montaje LVR-20 B; LVC-21 B; LV		
Nº	Pieza	
Nº	Modificación	
(11)	Modificar cableado para la nueva estética	
(12)	Corrección nueva estética	
(13)	Eliminar versión W del plano	
(14)	Modificar cableado presostato debido a cambio por par	
(15)	LVC-21C bertsioa sartu	
(16)	Aldatu kalderineko kontaktorea Z213007 --> Z203050	
	Firma	Fecha
Dibujado	S. N.	19-10-94
Proyectado		
Comprobado		
Escala		

Plano hau ez daitelke erabili ez berritza gure

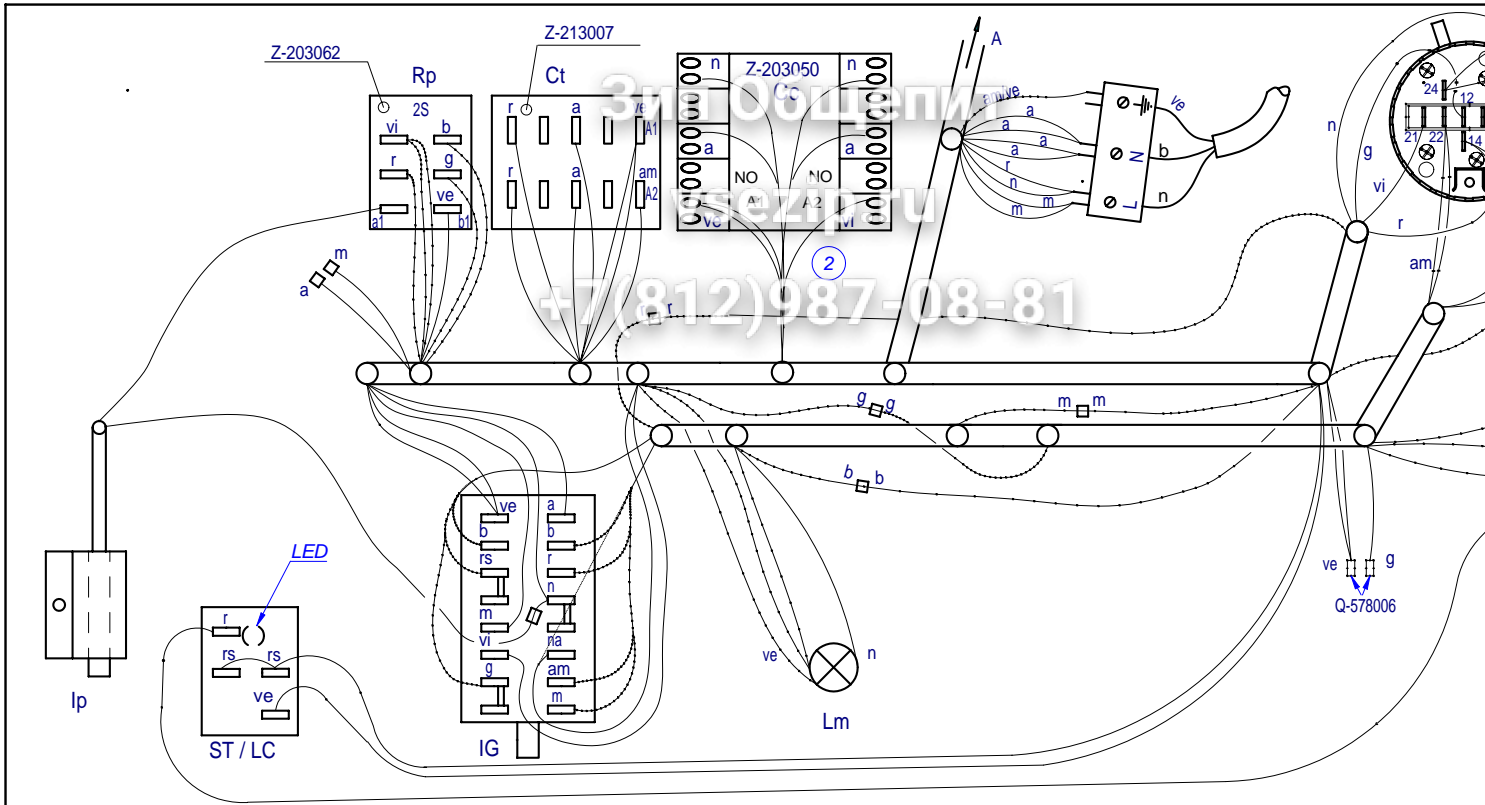

Calderín / Boiler Agua Fria / Cold water

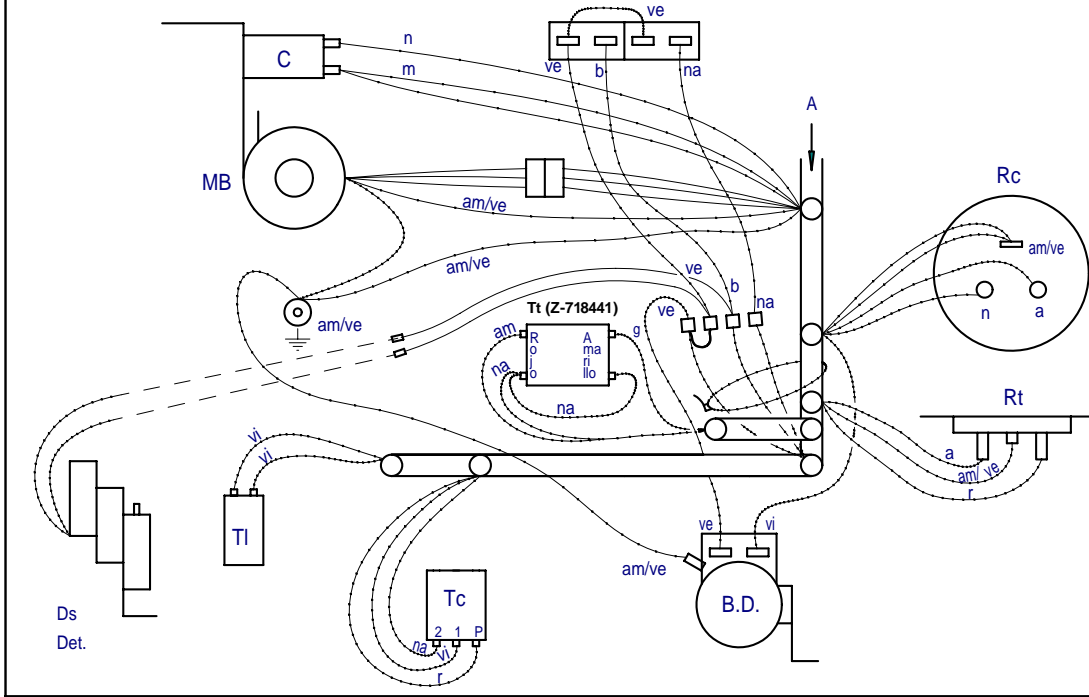

ESQUEMA MONTAJE LVC-21W		
Zk./Nº	Pieza	
Zk./Nº	Aidaketa/Modificaciones	
1	Modificar cableado presotato por cambio e	
2	Aldatu kalderineko kontaktorea Z213007 --	
-	-	-
-	-	-
-	-	-
Marratzua/Dibujado	Sinadura/Firma	Data/Fe
Proiektatua/Proyectado	S.N.	2006-12
Egiaztatua/Comprobado	ENERITZ	-
Eskala/Escala	-	-
Plano hau ezin daiteke er		

Зип Общепит LV 2100 - B , VGL 10

vsezip.ru

208-220-240 V. 1Ph

380-415 V. 3N

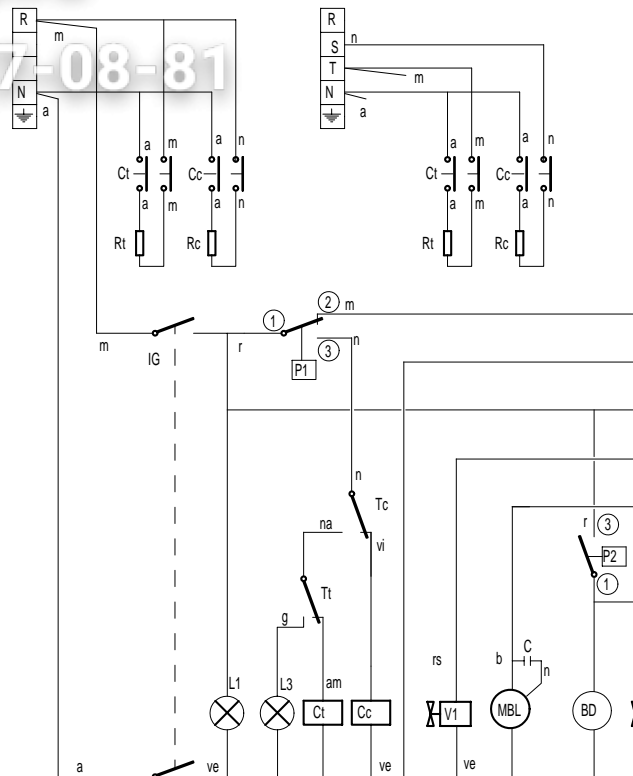
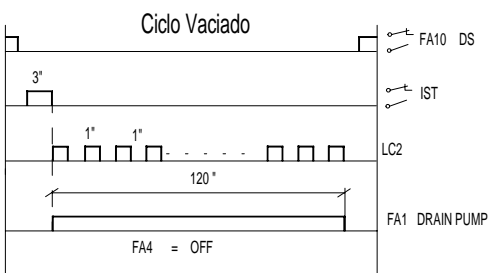
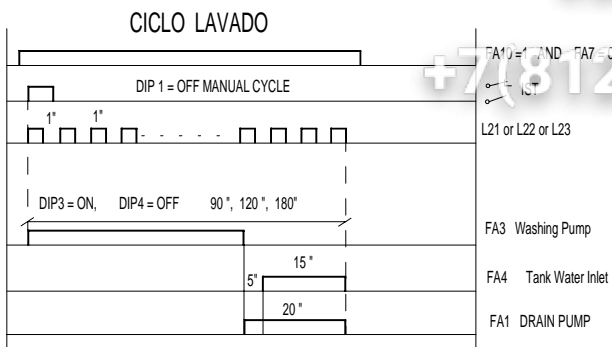

-		Esquema teorico LV 2100 - B	
Zk./Nº		Pieza	
Zk./Nº		Aldaketa/Modificaciones	
1		VGL 10 MODELOA SARTU	
.		.	
.		.	
.		.	
.		.	
		Sinadura/Firma	Data/Fe
Marratzua/Dibujado		M.Maillo	30-03-2
Proiektatua/Proyectado		M.Maillo	30-03-2
Egiazatua/Comprobado		ENERITZ	30-03-2
Eskala/Escala			
-			
Plano hau ezin daiteke er			

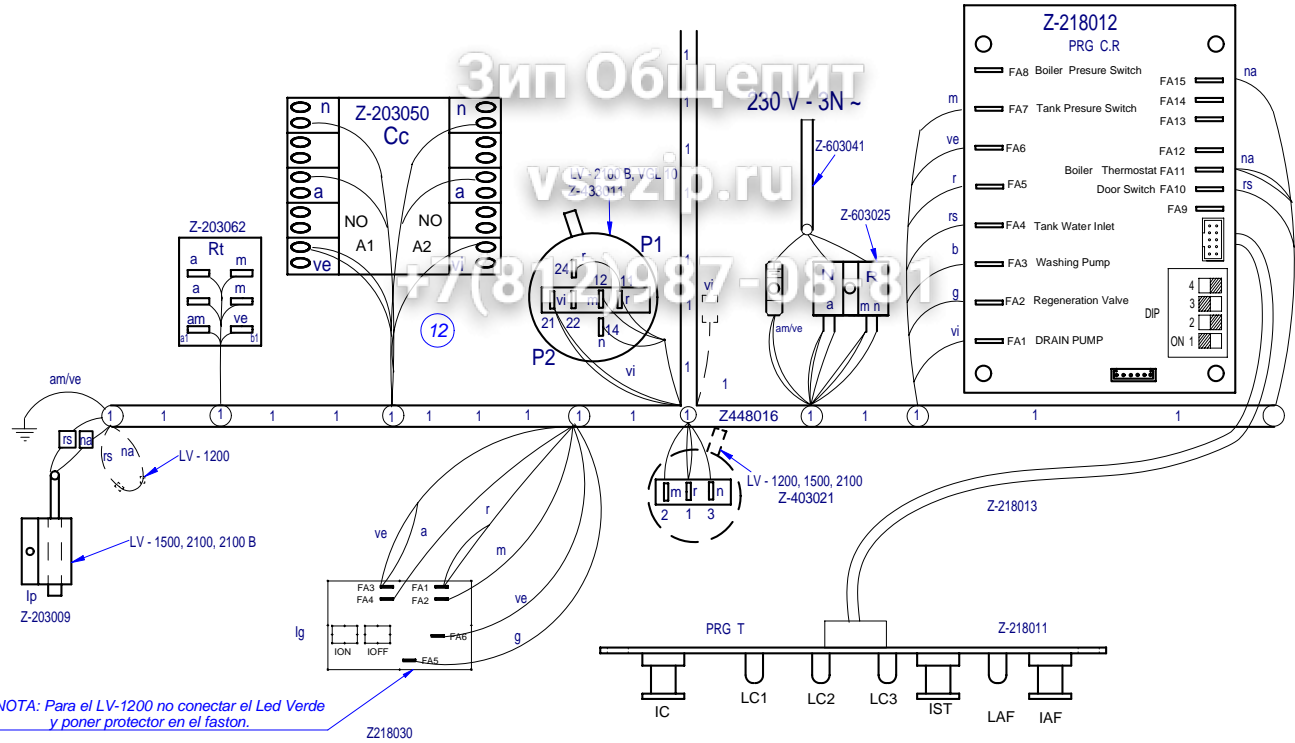

NOTA: Para el LV-1200 no conectar el Led Verde y poner protector en el faston.

Nota: Todos los cables hembra que queden sin conectar se les colocaran una funda macho Q-578006

ESQU
 LV 120
 LV 150
 LV 210

LEYEN
 INDICAD

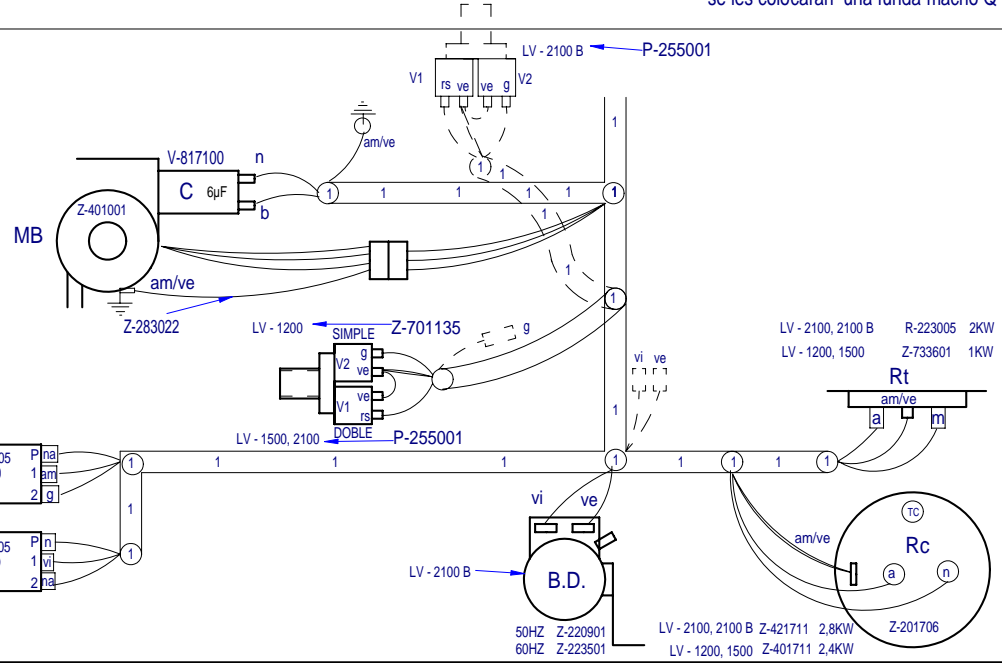

Plano montaje LV EDESA		
Nº	Pieza	
Nº	Modificacion	
(1)	Aldatu kalderineko kontaktorea Z213007 -> Z203050	
Firma		Fecha
Dibujado		ecarrascal
Proyectado		ecarrascal
Comprobado		ENERITZ
Escala		
Plano hau ez daitelke erabili ez berritza gure		