

vsezip.ru  
+7 812 987-08-81

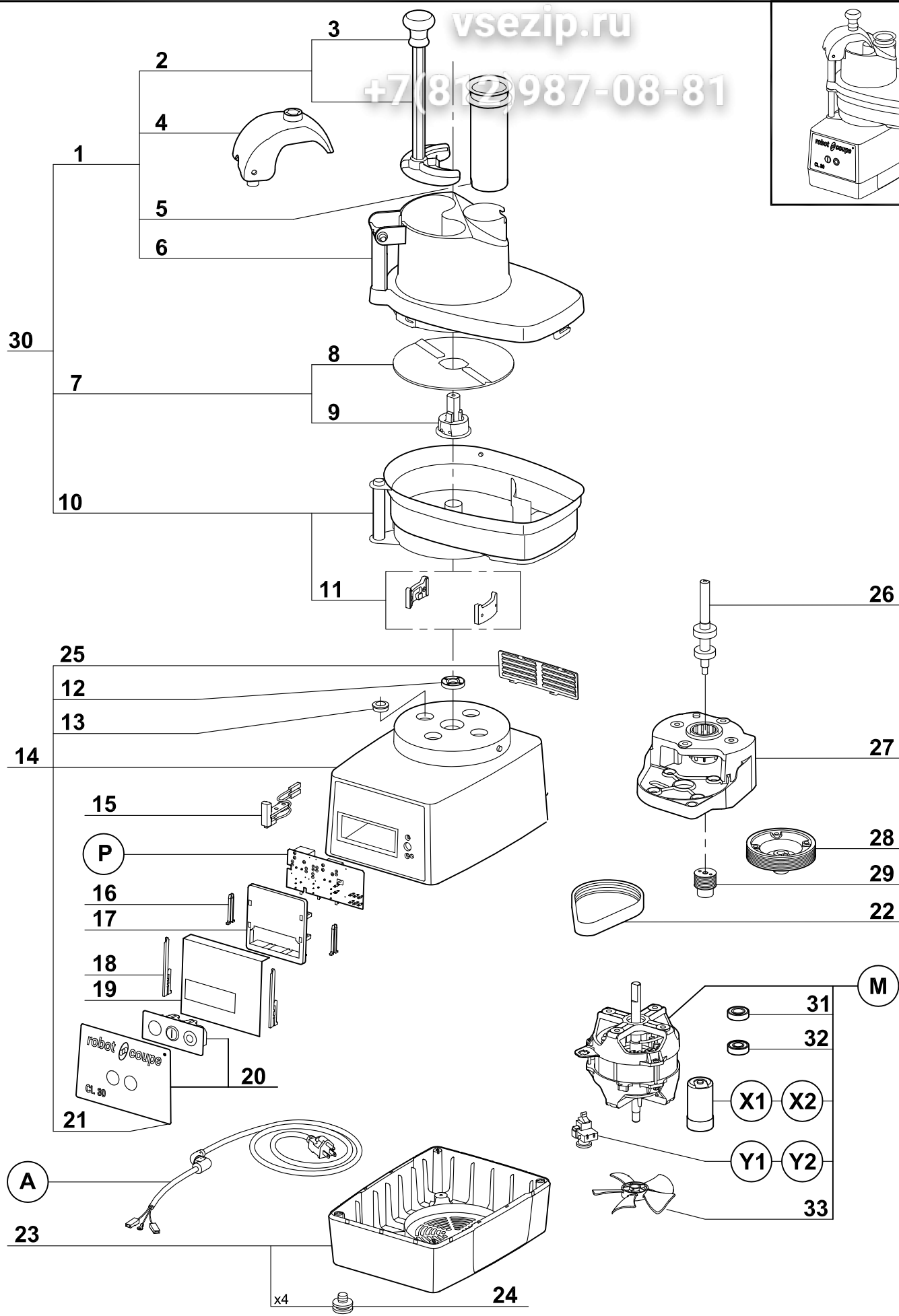

Pos.	Part No	Beschreibung	Pos.	Part No	Beschreibung
A	504274	ANSCHLUSSKAB SURM EUR			
M	3122	H50 CL30A 230/50/1			
P	103691	PLATINE R301D/CL30 230V			
X1	600018	KONDENSATOR 60MF 250/290V			
X1	600018	KONDENSATOR 60MF 250/290V			
X1	600018	KONDENSATOR 60MF 250/290V			
Y2	500289	RELAIS MTRPH46-39			
Y2	500289	RELAIS MTRPH46-39			
Y2	500289	RELAIS MTRPH46-39			
001	117079	GEMUSESCHNEIDEROBERTEIL			
002	29324	PUSHER ACC CL30/R302/PLUS			
003	102021	STOPFERGRIFF			
004	102020	STOPFERFUHRUNG R302/R402			
005	102022	KAROTTEN STOPFER CL30			
006	102016	DECKEL CL CL30/R302			
007	102019	AUSWURFSCHEIBE . CL30/R302			
008	117092	AUSWERFERSCHEI.ZWEISEITIG			
009	117091	NABE AUSWURFSCHEIBE			
010	104076	GEMUSESCHN.SCHUSS. R401			
011	29081	VERRIEGELUNGSPLATTE R3/R301U KOMPL.			
012	501010	DICHTUNGSRING 15X35X6			
013	104070	ABDECKKAPPE R401 M.GRAU			
014	39117	MOTORGEHAUSE CL30A			
015	29356	REEDKONTAKT			
016	102913	SICHERUNGSSTIFT BEDIENF			
017	102911	LEITERPLATTENHALTER. R302			
018	117703	SICHERUNGSSTIFT TASTENPLA			
019	104131	ISOLATION PLATINE			
020	39115	BEDIENFELD KPL CL30A			
021	407705	FRONTPLATTE CL30A			
022	503940	RIEMEN POLY V414J8MA			
023	39112	GEHAUSE UNTEN PLAST R402			
024	101082	FUSS			
025	104122	LUFTUNGSGITTER R401			
026	29604	ANTRIEBSWELLE R302 VV			
027	104125	GETRIEBEGEHAUSE			
028	102923	ANTRIEBSRAD R302VV			
029	102924	MOTRORRITZEL R302 VV			
030	27252	ZUBEHOR G-SCHNEIDE R401			
031	504229	LAGER 6002			
032	600457	LAGER 6201 2RS			
033	117610	VENTILATOR RC			

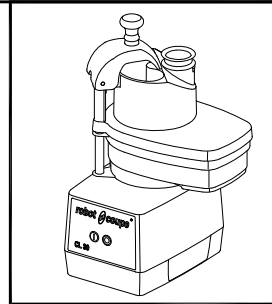

R 201 / R 211  
R 301  
R 301 Ultra  
R 401  
CL 20 / CL 25













R 402  
R 402 V.V.  
CL 30

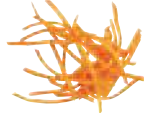
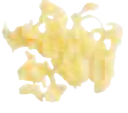

## DISCS



R 502/R 502 V.V.  
R 602/R 602 V.V.  
CL 50/CL 50 Ultra  
CL 52/CL 55/CL 60

	R 201 / R 211 R 301 R 301 Ultra R 401 CL 20 / CL 25	R 402 R 402 V.V.	CL 30	DISCS	R 502/R 502 V.V. R 602/R 602 V.V. CL 50/CL 50 Ultra CL 52/CL 55/CL 60
<b>SLICERS</b>				<b>Almonds 0,6 mm</b>	28166
				<b>0,8 mm</b>	28069
	27051	27051		<b>1 mm</b>	28062
	27555	27555		<b>2 mm</b>	28063
	27086	27086		<b>3 mm</b>	28064
	27566	27566		<b>4 mm</b>	28004
	27087	27087		<b>5 mm</b>	28065
	27786	27786		<b>6 mm</b>	
				<b>8 mm</b>	28066
				<b>10 mm</b>	28067
				<b>14 mm</b>	28068
				<b>4 mm for cooked potatoes</b>	27244
				<b>6 mm for cooked potatoes</b>	27245
<b>RIPPLE CUT SLICERS</b>	27621	27621		<b>2 mm</b>	27068
				<b>3 mm</b>	27069
				<b>5 mm</b>	27070
<b>GRATERS</b>	27588	27588	27148	<b>1,5 mm</b>	28056
	27577	27577	27149	<b>2 mm</b>	28057
	27511	27511	27150	<b>3 mm</b>	28058
				<b>4 mm</b>	28073
				<b>5 mm</b>	28059
	27046	27046		<b>6 mm</b>	
				<b>7 mm</b>	28016
	27632	27632		<b>9 mm</b>	28060
	27764	27764		<b>Parmesan</b>	28061
	27191	27191		<b>Röstis potatoes</b>	27164
	27078	27078		<b>0,7 mm for horseradish paste</b>	
	27079	27079		<b>1 mm for horseradish paste</b>	28055
	27130	27130		<b>1,3 mm for horseradish paste</b>	
<b>JULIENNE</b>				<b>1 x 8 mm</b>	28172
				<b>1 x 30 onions/Cabbage</b>	28153
	27599	27599		<b>2 x 2 mm</b>	28051
	27080	27080		<b>2 x 4 mm</b>	27072
	27081	27081		<b>2 x 6 mm</b>	27066
				<b>2 x 8 mm</b>	27067
				<b>2 x 10 mm</b>	28173
				<b>3 x 3 mm</b>	28101
	27047	27047		<b>4 x 4 mm</b>	28052
	27610	27610		<b>6 x 6 mm</b>	28053
	27048	27048		<b>8 x 8 mm</b>	28054



	R 402 / R 402 V.V. CL 30	DISCS	R 502 / R 502 V.V. R 602 / R 602 V.V. CL 50 / CL 50 Ultra CL 52 / CL 55 / CL 60
<b>DICING EQUIPMENTS</b>    1 DICING GRID + 1 SLICER	■ 27113	5 x 5 x 5 mm	■ 28110
	■ 27114	8 x 8 x 8 mm	■ 28111
	■ 27298	10 x 10 x 10 mm	■ 28112
		12 x 12 x 12 mm	
		14 x 14 x 5 mm (mozzarella)	■ 28181
		14 x 14 x 10 mm	■ 28179
		14 x 14 x 14 mm	■ 28113
	20 x 20 x 20 mm	■ 28114	
	25 x 25 x 25 mm	■ 28115	
	50 x 70 x 25 mm (salad)	■ 28180	
<b>FRENCH FRIES EQUIPMENTS</b>  	▲ 27116	8 x 8 mm	▲ 28134 (1)
	▲ 27117	10 x 10 mm	▲ 28135 (1)
		10 x 16 mm	▲ 28158 (1)

## REMINDER



- **Dicing equipment** delivered with : 1 dicing grid + 1 slicing disc.
  - ▲ **French Fries equipment** delivered with : 1 French Fries disc + 1 slicing disc.
- (1) Not available for CL 55 and CL 60 with pusher feed head

## ACCESSORIES

	REF.
<b>POLYCARBONATE WALL DISCS HOLDER</b> For discs R201 to R402 V.V. CL20 to CL30  	27019
<b>POLYCARBONATE SET OF DISCS</b> For R502 to R602 V.V. discs CL50 to CL60 V.V.  	27258
<b>STAINLESS STEEL WALL DISCS HOLDER</b> (receives 6 discs)  	101230
<b>D-CLEAN KIT : CLEANING TOOL DICING GRIDS</b>  	NEW 39881