



Зип Общепит

vsezip.ru

R/RS 16/22

SPARE PARTS MANUAL

PUBLICATION DATE: 12 Jun 2007

504605 B

RIGID MOUNTED WASHER EXTRACTORS

+7(812)987-08-81

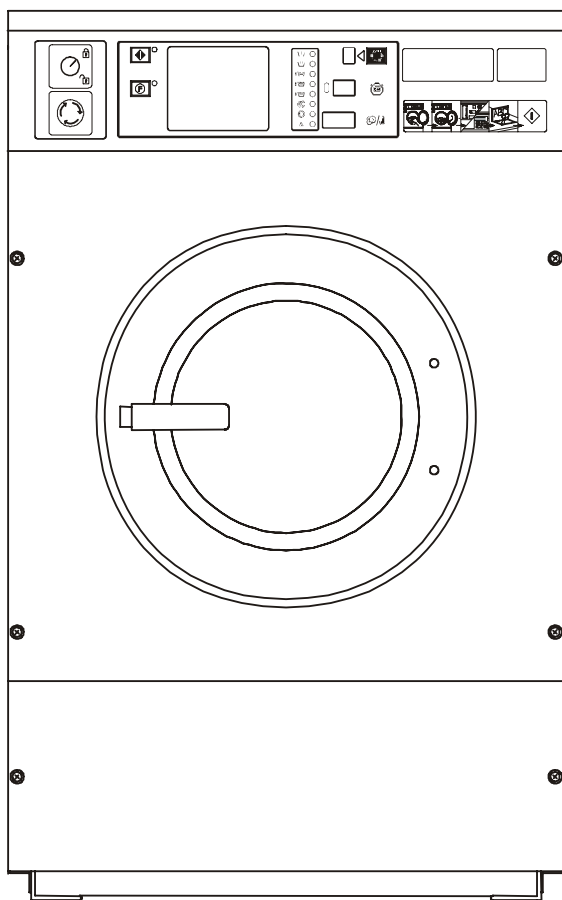

505523A

SPARE PARTS MANUAL

CATALOGUE DES ACCESSORIES

ERSATZTEIL-KATALOG

CATÁLOGO DE PIEZAS DE REPUES

Зип Общепит

vsezip.ru

+7(812)987-08-81

PREFACE

Original or identical parts must be used for replacement in the machine. After servicing replace secure all panels in original way and keep this manual in a secured place for future reference. When calling or writing about your machine, be sure to mention type, model and serial number. Model, type and serial number are located on name plate on rear of the machine or on the last manual page. The manufacturer reserves himself the right to change the specifications of manual at any time, without previous notice. The data and presentation are given only for information. Please note that it regards only general information, since it is impossible to give in the manual the complete survey of all specific details on all the machines included in our line. The spare parts manual is for machines with capacity:
16 kg/ 35 lbs as from serial number XXX/10480
22 kg/ 50 lbs as from serial number XXX/09449

CONTENTS

1. Frame
2. Cabinet
3. Control panel for mechanical programmer
4. Coin meter and mechanical timer
5. Soap hopper and cover
6. Door lock
7. Hoses
8. Rear panel
9. Drive
10. Electrical tray
11. Tub and drum
12. Door
13. Trunnion
14. MCB control panel
15. Card control panel
16. Frequency drive
19. Control panel with mechanical buttons

INTRODUCTION

Pour changer les pièces détachées de la machine il faut utiliser les pièces d'origines ou anciennes. Après une intervention de service, mettez tous les panneaux dans un état original et laissez ce mode d'emploi dans un endroit à l'abri pour les informations éventuelles. Si vous téléphonez ou écrivez en ce qui concerne votre machine, indiquez toujours le type, modèle et numéro de série de la machine. Le type, modèle et le numéro de série de la machine sont indiqués sur la palquette indicatrice sur le derrière de la machine ou sur la page dernière du mode d'emploi. Le fabricant se réserve le droit de réaliser les changements des spécifications qui sont indiquées dans le catalogue à tout moment et sans avertissement antérieur. Toutes les données ne sont que informatives. Prenez en compte s.v.p. que ce catalogue ne concerne que les données informatives, parce que il n'est pas possible d'indiquer la liste complète de tous les détails de toutes nos machines de notre production. Catalogue est désigné pour les machines avec la capacité/ à partir du numéro de fabrication:
16 kg/ 35 lbs XXX/10480
22 kg/ 50 lbs XXX/09449

CONTENU

1. Châssis
2. Capotage
3. Panneau de commande avec le programateur mécanique
4. Monnaie et programateur
5. Bac à poudre avec la couvercle
6. Serrure de la porte
7. Tuyau
8. Panneau arrière
9. Traction
10. Électro-pieces
11. Tambour et la cure
12. Porte
13. Moyeu
14. Panneau de commande MCB
15. Panneau de commande avec un programateur à la carte
16. Commnade de fréquence
19. Panneau de commande et aux boutons mécaniques

VORWORT

Für einen Austausch an der Waschmaschine müssen Original- oder ursprüngliche Teile verwendet werden. Nach einem Serviceeingriff sämtliche Paneels im ursprünglichen Zustand absichern, und dieses Handbuch an einer sicheren Stelle für eventuelle Informationen aufbewahren. Falls Sie telefonieren oder schreiben betreffs Ihre Maschine, immer den Typ, das Modell und Seriennummer angeben. Typ, Modell und Seriennummer sind an dem Herstellschild an den Maschinenhinterseite angeführt, oder an der Handbuchhinterseite. Der Hersteller behält sich das Recht vor, jederzeit ohne irgendwelche vorherige Bekanntmachung Änderungen von Spezifikationen, in diesem Katalog angeführt, vorzunehmen. Sämtliche Angaben sind lediglich informativ. Nehmen Sie, bitte, zur Kenntnis, daß dieser Katalog lediglich allgemeine Informationen betrifft, da es nicht möglich ist, eine komplette Übersicht aller Details über sämtliche Maschinen unserer Produktion anzuführen. Der Katalog ist für Maschinen mit einem Kapazität
16 kg/ 35 Pf ab der Herstell-Nr. XXX/10480
22 kg/ 50 Pf ab der Herstell-Nr. XXX/09449

INHALT

1. Rahmen
2. Mantel
3. Steuerpaneel für mechanischem Programator
4. Münzgerät und Programator
5. Füllbehälter und Deckel
6. Türschloß
7. Schlauch
8. Heckpaneel
9. Antrieb
10. Elektroteile
11. Wasch- und Außentrommel
12. Tür
13. Nabe
14. Steuerpaneel MCB
15. Steuerpaneel mit Kartenprogramator
16. Frequenzantrieb
19. Steuerpaneel mit mechanischen taster

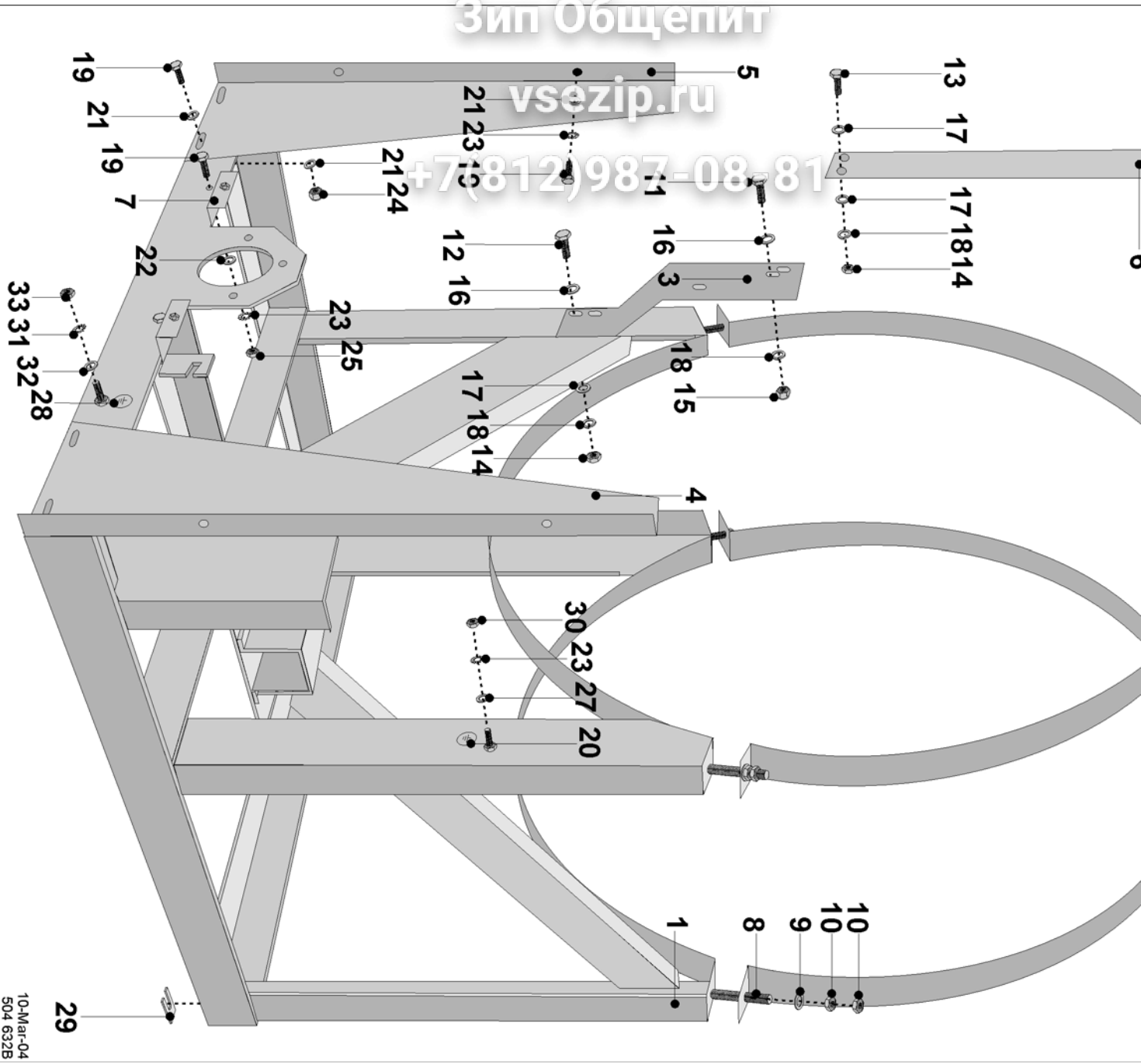

Зип Общепит

N°	Code	Description	Designation	Bezeichnung
1	R16101000010	Frame (16kg-35lbs)	Bâti (16kg-35lb)	Ständer (16kg-35lb)
2	R22101000010	Frame (22kg-50lbs)	Bâti (22kg-50lb)	Ständer (22kg-50lb)
3	R16101001812	Tub clamp	Liure	Band
3	R16100010213	Tub support brace	Support de tambour	Trommelhalter
4	R16100011613	Support bracket right side panel	renfort capot droit	Rechtes Capotageversteifung
5	R16100011513	Support bracket left side panel	renfort capot gauche	Linkes Capotageversteifung
6	R16100011714	Holder steam tube	Support arrivée vapeur	Halter Dampfzuleitung
7	R16123000014	Connection part back plate	Support panneau arrière	Halter Hinterabdeckung
8	309933001450	Screw M14x50	Vis M14x50	Schraube M14x50
9	311125000014	Washer 14	Rondelle 14	Unterlegscheibe 14
10	310934000014	Nut M14	Écrou M14	Mutter M14
11	309933000845	Screw M8x45	Vis M8x45	Schraube M8x45
12	309933000835	Screw M8x35	Vis M8x35	Schraube M8x35
13	309933000825	Screw M8x25	Vis M8x25	Schraube M8x25
14	310934000008	Nut M8	Écrou M8	Mutter M8
15	310985000008	Self locking nut M8	Écrou de blocage M8	Selbstsichernde Mutter M8
16	311902100008	Washer 24x8,5x2	Rondelle 24x8,5x2	Unterlegscheibe 24x8,5x2
17	311125000008	Washer 16x8,4x1,6	Rondelle 16x8,4x1,6	Unterlegscheibe 16x8,4x1,6
18	311127000008	Spring lock washer M8	Rondelle élastique M8	Unterlegscheibe M8
19	309933000620	Screw M6x20	Vis M6x20	Schraube M6x20
20	548200000025	Earth plate	Écusson mise à la terre	Erdungsschild
21	311734900006	Washer 17x6,4x3 DIN 7349	Rondelle 17x6,4x3 DIN 7349	Unterlegscheibe 17x6,4x3 DIN 7349
22	311125000006	Washer 12x6,4x1,6	Rondelle 12x6,4x1,6	Unterlegscheibe 12x6,4x1,6
23	311679824006	Lock washer external teeth M6	Rondelle à crans multiples M6	Unterlegscheibe M6
24	310985000006	Self locking nut M6	Écrou de blocage M6	Selbstsichernde Mutter M6
25	310934000006	Nut M6	Écrou M6	Mutter M6
27	311125240006	Washer 11x6,4x1,6 stainless steel	Rondelle 11x6,4x1,6 inoxl	Unterlegscheibe 11x6,4x1,6 nichtrostend
28	PRI551010001	Earth plate	Écusson mise à la terre	Erdungsschild
29	510684	Frame shim	Rondelle d'équilibrage	Ausgleichsscheibe
30	310934240006	Nut M6	Écrou M6	Mutter M6
31	311679824008	Washer M8	Rondelle M8	Unterlegscheibe M8
32	311125240008	Washer M8	Rondelle M8	Unterlegscheibe M8
33	310934240008	Nut M8	Écrou M8	Mutter M8

Зип-Общепит

vsezip.ru

+7(812)987-08-81

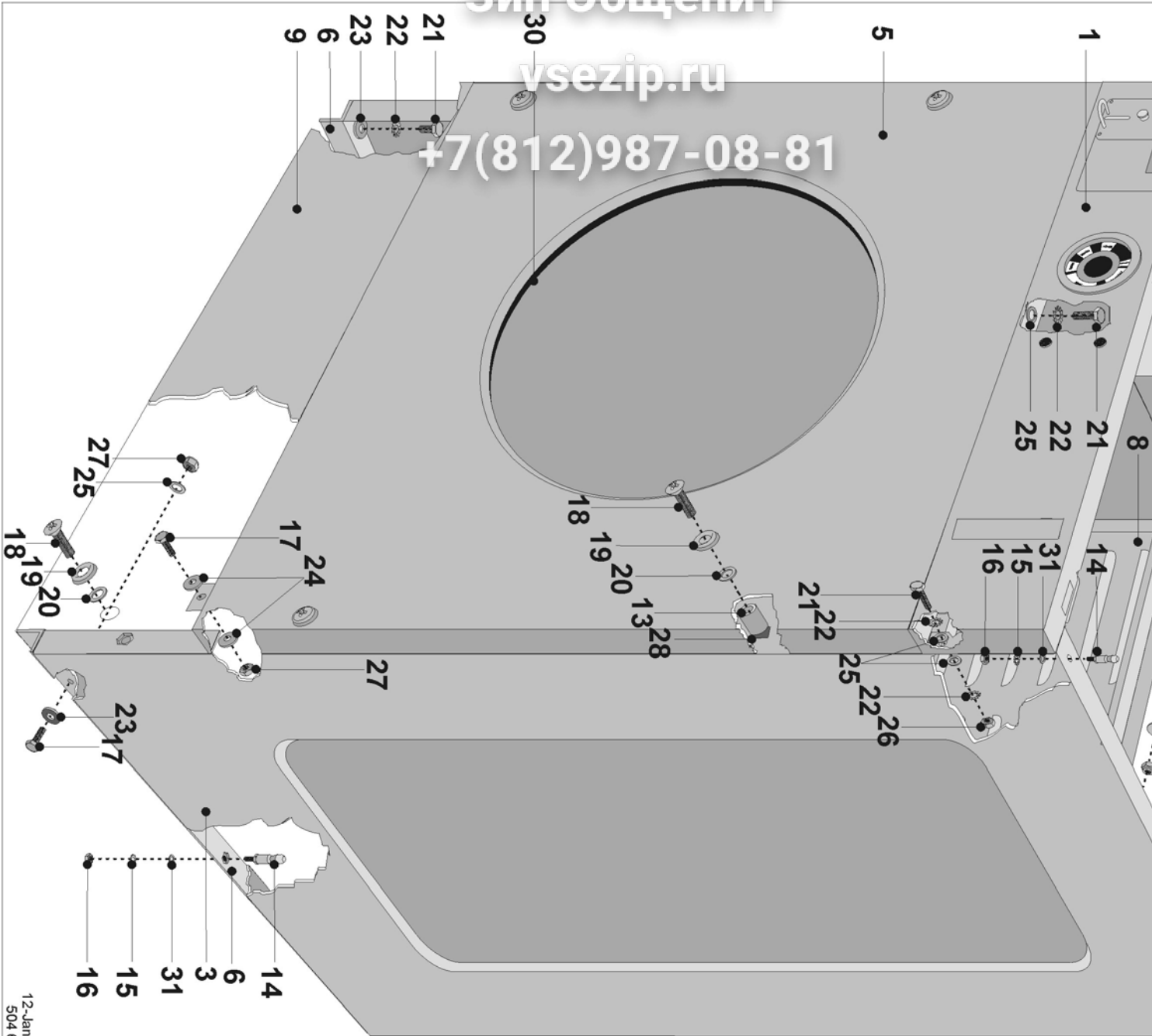

Зип Общепит

N°	Code	Description	Designation	Bezeichnung
1	R16116200011	Control panel push button	Panneau de commande à touches	Betätigungspaneel mit Drucktaste
2	M16116600011	Control panel coin meter	Panneau de commande monnayeur	Betätigungspaneel mit Münzvorrichtung
	514831	Box electrical components components	Panneau d'appareillage	Gerätepaneel
	514832	Box electrical components, valid for export USA	Panneau d'appareillage USA	Gerätepaneel USA
3	M10114700223	Holder of condensers	Support du condensateur	-Halter Kondensator
	R16114300011	Side panel right (16kg-35lbs)	Panneau latéral droit (16kg-35lb)	Rechtes seiten Abdeckung (16kg-35lb)
	R22114300011	Side panel right (22kg-50lbs)	Panneau latéral droit (22kg-50lb)	Rechtes seiten Abdeckung (22kg-50lb)
4	R16114100011	Side panel left (16kg-35lbs)	Panneau latéral gauche (16kg-35lb)	Linkes seiten Abdeckung (16kg-35lb)
5	R22114100011	Side panel left (22kg-50lbs)	Panneau latéral gauche (22kg-50lb)	Linkes seiten Abdeckung (22kg-50lb)
	R16115100013	Front panel push button complete, stainless steel, round door	Panneau avant à touches - inox	Vorderpaneel nichtrostend mit Drucktaste
	501444	Front panel push button complete, white, round door	Panneau avant - blanc	Vorderpaneel weiß
	501446	Front panel push button complete, yellow, round door	Panneau avant - jaune	Vorderpaneel gelb
	501445	Front panel push button complete, orange, round door	Panneau avant - orange	Vorderpaneel orange
	507784	Front panel push button complete, blue, round door	Panneau avant - bleu	Vorderpaneel blau
	500179	Front panel push button complete, stainless steel, square door	Panneau avant porte angulaire - inox	Vorderpaneel kantige Tür nichtrostend
	509831	Front panel push button complete, white, square door	Panneau avant porte angulaire - blanc	Vorderpaneel kantige Tür weiß
	R16115400013	Front panel for card control complete, stainless steel	Panneau avant programmeur à cartes - inox	Vorderpaneel mit Karteprogrammatoren nichtrostend
	501457	Front panel for card control complete, white	Panneau avant - blanc programmeur à cartes	Vorderpaneel weiß mit Karteprogrammatoren
	501459	Front panel for card control complete, yellow	Panneau avant - jaune programmeur à cartes	Vorderpaneel gelb mit Karteprogrammatoren
	501458	Front panel for card control complete, orange	Panneau avant - orange programmeur à cartes	Vorderpaneel orange mit Karteprogrammatoren
6	R16118700013	Support right side panel (16kg-35lbs)	Cornière d'assemblage-droite (16kg-35lb)	Rechtes Winkelleisten (16kg-35lb)
	R16118500013	Support left side panel (16kg-35lbs)	Cornière d'assemblage-gauche (16kg-35lb)	Linkes Winkelleisten (16kg-35lb)
	R22118500013	Support left side panel (22kg-50lbs)	Cornière d'assemblage-gauche (22kg-50lb)	Linkes Winkelleisten (22kg-50lb)
	R22118700013	Support right side panel (22kg-50lbs)	Cornière d'assemblage-droite (22kg-50lb)	Rechtes Winkelleisten (22kg-50lb)
8	R16100011211	Back plate	Panneau arrière	Hintere Abdeckung
9	R16100011211	Back plate steam	Panneau arrière (chauffage vapeur)	Hintere Abdeckung (Dampfheizung)
	R16100010312	Service panel stainless steel	Panneau de service - inox	Servicepaneel nichtrostend
	501438	Service panel white	Panneau de service - blanc	Servicepaneel weiß
	501440	Service panel yellow	Panneau de service - jaune	Servicepaneel gelb
	501439	Service panel orange	Panneau de service - orange	Servicepaneel orange
	507711	Service panel blue	Panneau de service - bleu	Servicepaneel blau
10	R16118300013	Cross beam	Support	Gerätepaneelhalter
11	R16118100013	Holder box el. components (16kg-35lbs)	Poutre raidisseuse (16kg-35lb)	Gerätepaneelträger (16kg-35lb)
	R22118100013	Holder box el. components (22kg-50lbs)	Poutre raidisseuse (22kg-50lb)	Gerätepaneelträger (22kg-50lb)
12	PRI610000078	Holder top panel	Tringle	Zugstange
13	R07114002414	Distance tube	Tube d'écartement	Distanzrohr
14	PRI611000023	Srv pin	Téton	Zapfen
15	311679800005	Lock washer external teeth M5	Rondelle à crans multiples M5	Unterlegscheibe M5
16	310934000005	Nut M5	Écrou M5	Mutter M5
17	309933000625	Screw M6x25	Vis M6x25	Schraube M6x25
18	309966240650	Screw M6x50 stainless steel	Vis inox M6x50	Schraube M6x50 nichtrostend
19	PRI247000001	Finishing washer	Rondelle	Formunterlage
20	PRI521002001	Washer 15x7x3	Rondelle 15x7x3	Unterlegscheibe 15x7x3
21	309595124612	Screw M6x12 BN5951	Vis M6x12 BN5951	Schraube M6x12 BN5951

Зип Общепит

vsezip.ru

+7(812)987-08-81

Зип Общепит

vsezip.ru

+7(812)987-08-81

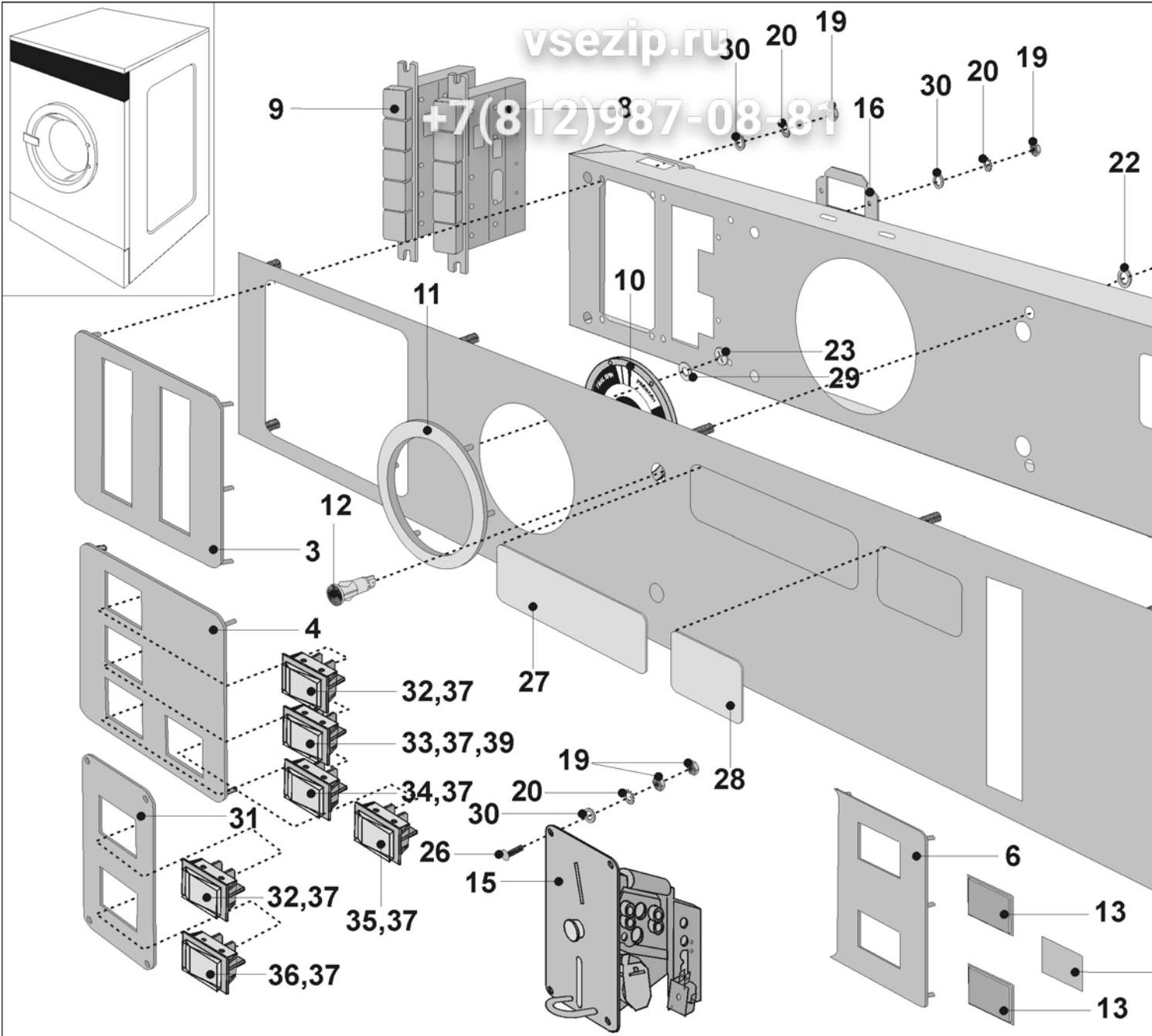

Зип Общепит

N°	Code	Description	Designation	Bezeichnung
1	R16116200011	Control panel with buttons	Pupitre de commande touches fonction	Steuertafel mit Taster
2	M16116600011	Control panel with coin meter	Pupitre de commande monnayeur	Steuertafel mit Münzgerät
	PRI549000077	Facial panel 20°C on 5	Devanture pupitre 20°C, 5 programmes	Tafelschild 20°C im 5. Programm
	PRI549000078	Facial panel 30°C on 5	Devanture pupitre 30°C, 5 programmes	Tafelschild 30°C im 5. Programm
	PRI549000091	Facial panel Triple load plus (16kg-35lbs)	Devanture pupitre Triple load plus (16kg-35lb)	Tafelschild Triple load plus (16kg-35lb)
	PRI549000092	Facial panel Multi load (22kg-50lbs)	Devanture pupitre Multi load (22kg-50lb)	Tafelschild Multi load (22kg-50lb)
	PRI549000102	Facial panel USA (16kg-35lbs)	Devanture pupitre USA (16kg-35lb)	Tafelschild USA (16kg-35lb)
	PRI549000103	Facial panel USA (22kg-50lbs)	Devanture pupitre USA (22kg-50lb)	Tafelschild USA (22kg-50lb)
3	PRI549152065	Insert plate push 15 buttons	Plaque - 15 boutons	Tasterschild - 15 Taster
4	PRI549155065	Insert plate push 3 buttons	Plaque - 3 boutons	Tasterschild - 3 Taster
	PRI549158065	Insert plate with instructions	Plaque avec les intructions	Tasterschild mit Hinweisen
5	PRI549154065	Insert plate	Plaque	Schild
6	PRI549000059	Insert plate for coin counter	Plaque monnayeur	Münzgerätschild
	PRI549001059	Insert plate	Plaque	Schild
	PRI549004059	Insert plate for coin counter with instructions	Plaque monnayeur avec les intructions	Münzgerätschild mit Hinweisen
7	PRI348012091	Program selector switch	Bouton - poussoir	Tastersystem
8	PRI348016091	Program selector switch black	Bouton - poussoir Noir	Tastersystemschwarz
	PRI348014091	Function selection switch with black button	Fonction de commutateur du choix avec le bouton noir	Funktion Auswahlschalter mit schwarzem K
9	PRI348013091	Function selection switch	Fonction de commutateur du choix	Funktion Auswahlschalter
10	PRI543051072	Indicator disc English	Indicateur programme - anglais	Programmanzeige - englisch
11	PRI543056072	Indicator disc with symbols	Indicateur programme avec symboles	Programmanzeige mit Symbolen
	PRI543000073	Ornamental indicator disc ring	Bague ornamentale du disque d'indicateur	Zierring Indikatorscheibe
12	PRI349000032	Indicator lamp	Lampe - témoin	Meldeleuchte
13	PRI543072072	Plexi transparent	Altuglas transparent	Plexiglas transparent
14	PRI543075072	Plexi aluminium colour	Altuglas argenté	Plexiglas silber
	PRI543073072	Plexi transparent red	Altuglas rouge	Plexiglas rot
		Coins sticker (on request)	Plaque valeur monnaieaire (sur demande)	Münzenwert-Schild (Option)
15	PRI347001003	Coin meter token 5K	Monnayeur 5K	5K - Münzgerät
	PRI347001004	Coin meter token 7K	Monnayeur 7K	7K - Münzgerät
	PRI347001052	Coin meter token 10K	Monnayeur 10K	10K - Münzgerät
	PRI347000052	Coin meter token 12K	Monnayeur 12K	12K - Münzgerät
	PRI347000053	Coin meter token 15K	Monnayeur 15K	15K - Münzgerät
16	F01113500514	Rest on request	Reste à la demande	Rest auf Wunsch
19	310934000003	Fixation plate	Couvercle en tôle	Abdeckblech
20		Nut M3	Écrou M3	Mutter M3
		Lock washer external teeth M3	Rondelle à crans M3	Fächerunterlegscheibe M3
21	310934000004	Nut M4	Écrou M4	Mutter M4
22	311902100004	Washer 12x4,33x1 DIN 9021	Rondelle 12x4,33x1 DIN 9021	Unterlegscheibe 12x4,33x1 DIN 9021
23	PRI247010013	Securing washer 3	Rondelle de blocage 3	Sicherungsunterlegscheibe 3
24	PRI543000005	Silon washer	Rondelle de silon	Silon-Unterlegscheibe
25	311679800004	Lock washer external teeth M4	Rondelle à crans multiples M4	Fächerunterlegscheibe M4
26	PRI212000008	Bolt M3x10	Vis M3x10	Schraube M3x10
27	PRI549017011	Index plate	Plaque	Schild
28	PRI549013001	Index plate capacity 16kgs	Plaque chargement 16kg	Schild Füllung 16kg

Зип Общепит

vsezip.ru

+7(812)987-08-81

Зип Общепит

N°	Code	Description	Designation	Bezeichnung
28	PRI549014001	Index plate capacity 22kgs	Plaque chargement 22kg	Schild Füllung 22kg
	PRI549082001	Index plate capacity 35lbs	Plaque chargement 35lb	Schild Füllung 35 Lb
	PRI549083001	Index plate capacity 50lbs	Plaque chargement 50lb	Schild Füllung 50 Lb
29	PRI523000007	Washer	Rondelle à friction	Unterlegscheibe
30	31112500003	Washer 3,2	Rondelle 3,2	Unterlegscheibe 3,2
31	PRI549011061	Insert plate	Plaque	Tasterschild
32	PRI348000094	Knob-push button START	Bouton-poussoir START	Taster START
33	PRI348000006	Knob-push button ECO	Bouton-poussoir ECO	Taster ECO
34	PRI348000097	Knob-push button Prewash	Bouton-poussoir prélavage	Taster Vorwäsche
35	PRI348000007	Knob-push button STOP	Bouton-poussoir STOP	Taster STOP
36	PRI348001096	Plug	Bouchon	Stopfbuchse
37	PRI543000003	Push button cover	Protection bouton	Tasterabdeckung
38	F01113505514	Cover program switches	L'abri du commutateur de programmation	Abdeckung Programmum-schalter
39	PRI348000095	Acceleration button	Bouton accélération	Beschleunigungstaster

Зип Общепит

N°	Code	Description	Designation	Bezeichnung
1	M16115200013 504886 504887 504888	Front panel with coin meter complete, stainless steel, round door Front panel with coin meter complete, white, round door Front panel with coin meter complete, yellow, round door Front panel with coin meter complete, orange, round door	Panneau avant avec monnayeur porte ronde inox. Panneau avant avec monnayeur blanc porte ronde Panneau avant avec monnayeur jaune porte ronde Panneau avant avec monnayeur orange porte ronde	Fronttafel mit Münzgerät runder nichtrostender Fronttafel mit Münzgerät weiß runder Fronttafel mit Münzgerät gelb runder Fronttafel mit Münzgerät orange runder
	507783 500181 102105 507763	Front panel with coin meter complete, blue, round door Front panel with coin meter complete, stainless steel, square door Front panel with coin meter complete, yellow, square door Front panel with coin meter complete, blue, square door	Panneau avant avec monnayeur bleu porte ronde Panneau avant avec monnayeur inox porte angulaire Panneau avant avec monnayeur jaune porte angulaire Panneau avant avec monnayeur bleu porte angulaire	Fronttafel mit Münzgerät blau runder Fronttafel mit Münzgerät nichtrostend kantige Fronttafel mit Münzgerät gelb kantige Tür Fronttafel mit Münzgerät blau kantige Tür
4	R07A18100214	Cam for lock coin box	Cliquet monnayeur	Münzgerätschnapper
5	311734900006	Washer M6	Rondelle M6	Unterlegscheibe M6
6	PRI503000042	Indicator disc timer	Disque indicateur	Anzeigescheibe
7	R07116300014	Timer support	Support programmeur	Programmatorhalter
8	R07A18100114	Ornamental plate coin vault	Couvercle monnayeur	Münzgerätkappe
9	321848140028	Coin box	Armoire du monnayeur	Münzgeratkasten
10	501514	Ornamental part coin vault	Cadre monnayeur	Münzgerätrahmen
12	503134	Single coin vault	Boîtier monnayeur	Einfacher Münzgerätkasten
13	PRI610001028	Coin vault lock	Serrure	Münzgerätschloß
13		Securing washer, part of No. 13	Rondelle de blocage, partie de la position 13	Sicherungsunterlegscheibe, Positionsbestandteil 13
13		Small lock nut, part of No. 13	Écrou serrure, partie de la position 13	Schloßmutter klein, Positionsbestandteil 13
13		Lock big nut, part of No. 13	Écrou, partie de la position 13	Schloßmutter - große, Positionsbestandteil
16	PRI343000059	Timer, 230V	Programateur, 230V	Programmator, 230V
18	PRI347006060	Coin counter with LED display	Compteur à affichage LED	Münzenmesser mit LED-Anzeige
19	PRI347000060	Single coin counter	Compteur électronique	Einfacher elektronischer Münzenmesser
20	PRI346011007	Start relay	Relais de démarrage	Start-Relais
21	310934000003	Nut M3	Écrou M3	Mutter M3
22	PRI185024022	Mounting plate coin counter of start relay	Support relais	Relais-Halter
23	M16114002713	Coin vault support	Support monnayeur	Münzengeräthalter
24	311679800006	Lock washer external teeth M6	Rondelle à crans M6	Fächerunterlegscheibe M6
25	PRI231000004	Washer 12,5x6,6x1,6 DIN 126	Rondelle 12,5x6,6x1,6 DIN 126	Unterlegscheibe 12,5x6,6x1,6 DIN 126
26	309933000406	Bolt M4x6	Vis M4x6	Schraube M4x6
27	309084000410	Bolt M4x10	Vis M4x10	Schraube M4x10
28	311679824004	Lock washer external teeth M4	Rondelle à crans M4	Fächerunterlegscheibe M4
29	309798500306	Bolt M3x6	Vis M3x6	Schraube M3x6
30	309933000616	Bolt M6x16	Vis M6x16	Schraube M6x16
32	311125000004	Washer 4,3	Rondelle 4,3	Unterlegscheibe 4,3
33	311679800003	Lock washer external teeth M3	Rondelle à crans M3	Fächerunterlegscheibe M3
34	PRI211000033	Bolt M4x12	Vis M4x12	Schraube M4x12
36	310934000004	Nut M4	Écrou M4	Mutter M4
40	PRI231000038	Spring lock washer	Rondelle	Unterlegscheibe
42	PRI211002007	Screw M3x14	Vis M3x14	Schraube M3x14
43	311125000003	Washer 3,2	Rondelle 3,2	Unterlegscheibe 3,2
44	309595124612	Screw M6x12 BN 5951	Vis M6x12 BN 5951	Selbstschneidschraube M6x12 BN 5951
45	PRI229000004	Nut M6	Écrou M6	Mutter M6

Зип Общепит

vsezip.ru

+7(812)987-08-810

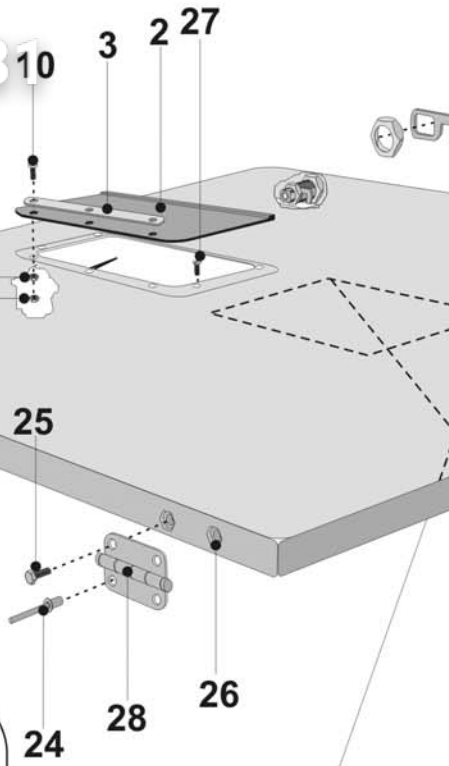
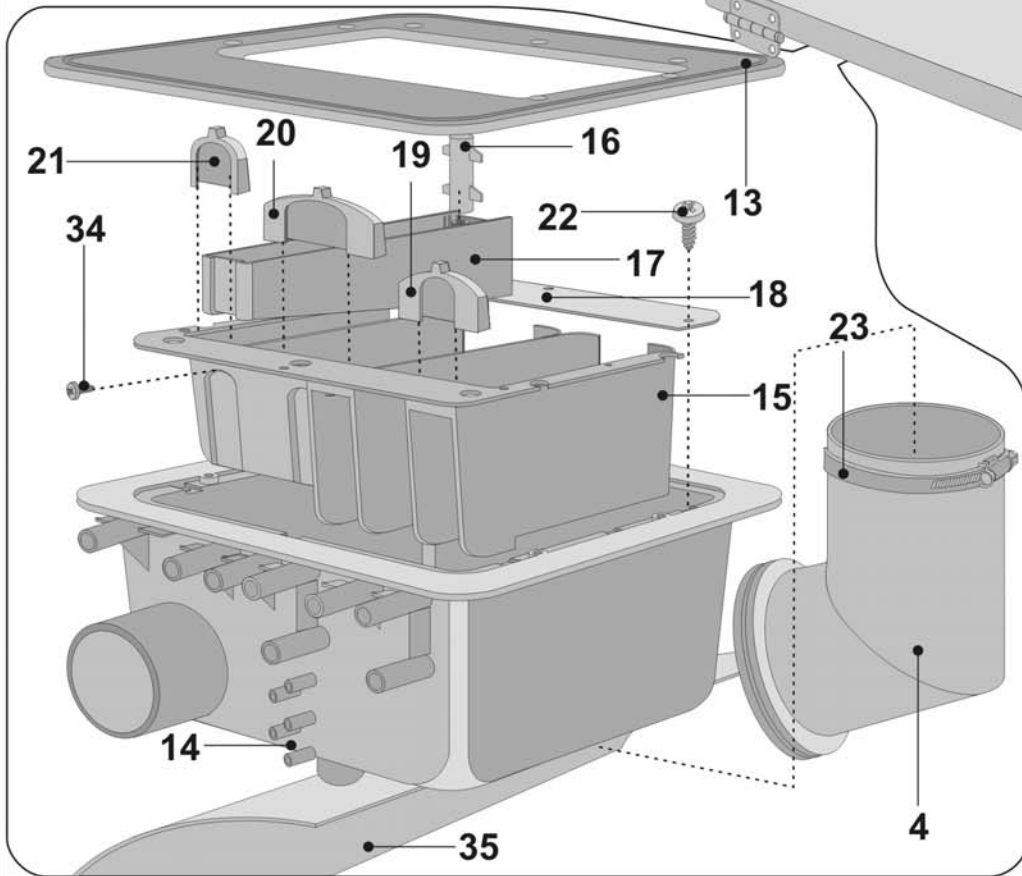
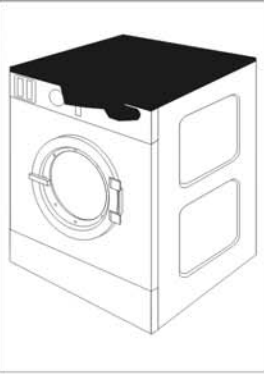

WAARSCHUWING: Bij het
Plaatsen van
Dit deel
vervoerd
ATTENTIE: Lors de la
pose de
Cet élément
il est
VORSICHT: Bei der
Montage
Dieses Bauteils
WACHSAM: Original
ersatzteile
ATTENZIONE: Prima di
installare
questo
componente

Зип Общепит

N°	Code	Description	Designation	Bezeichnung
1	521860	Top cover lid stainless steel (16kg-35lbs)	Couvercle inox (16kg-35lb)	Deckel nichtrostend (16kg-35lb)
1	521861	Top cover white enamel (16kg-35lbs)	Couvercle blanc (16kg-35lb)	Deckel weiß (16kg-35lb)
1	521862	Top cover yellow enamel (16kg-35lbs)	Couvercle jaune (16kg-35lb)	Deckel gelb (16kg-35lb)
1	521863	Top cover orange enamel (16kg-35lbs)	Couvercle orange (16kg-35lb)	Deckel orange (16kg-35lb)
1	521870	Top cover lid stainless steel (22kg-50lbs)	Couvercle inox (22kg-50lb)	Deckel nichtrostend (22kg-50lb)
1	521871	Top cover white enamel (22kg-50lbs)	Couvercle blanc (22kg-50lb)	Deckel weiß (22kg-50lb)
1	521872	Top cover yellow enamel (22kg-50lbs)	Couvercle jaune (22kg-50lb)	Deckel gelb (22kg-50lb)
1	521873	Top cover orange enamel (22kg-50lbs)	Couvercle orange (22kg-50lb)	Deckel orange (22kg-50lb)
2	PRI505038027	Rubber cover soap hopper	Couvercle trappe	Füllbehälterdeckel
3	F01121000214	Lath for rubber cover soap hopper	Lame	Leiste
4	PRI540000031	Rubber hose of soap hopper-tub	Coude d'alimentation	Füllbehälterkniestück
5	PRI610000007	Lock top panel	Verrou du couvercle	Deckelschloss
5		Big nut, part of No. 5	Grand petit, partie de la position 5	Mutter groß, Positionsbestandteil 5
5		Lock hook, part of No. 5	Cliquet court, partie de la position 5	Klinke kurz, Positionsbestandteil 5
5		Small nut, part of No. 5	Grand écrou, partie de la position 5	Mutter klein, Positionsbestandteil 5
6	PRI522000012	Washer	Rondelle	Unterlegscheibe
10	PRI211000033	Bolt M4x12	Vis M4x12	Schraube M4x12
11	310934240004	Nut M4	Écrou M4	Mutter M4
13	PRI505039027	Soap hopper rubber seal	Joint	Füllbehälterdichtung
14	PRI505040027	Soap hopper outer part	Coffret lessives	Füllbehälterkörper
15	PRI505041027	Soap hopper inner part	Cartouche	Füllbehältereinsatz
16	PRI505043027	Last rinse siphon part	Cilindre	Zylinder
17	PRI505042027	Last rinse box	Compartiment	Füllbehälterkammer
18	PRI505044027	Protection plate	Couvercle	Deckel
19	PRI505045027	Prewash drawer	Volet - pré lavage	Blende - Vorwäsche
20	PRI505046027	Main wash drawer	Volet - lavage	Blende - Wäsche
21	PRI505047027	Last rinse drawer	Volet - rinçage final	Blende - Endspülung
22	PRI215000006	Screw 3,5x9,5 stainless steel DIN 7971	Vis inox. 3,5x9,5 DIN 7971	Selbstschneidschraube 3,5x9,5 nichtrostend
23	PRI240000005	Hose clamp 90/110 DIN 3017	Collier 90/110 DIN 3017	Schlauchschele 90/110 DIN 3017
24	313250004063	Blind rivet 4x6,3	Rivet de traction 4x6,3	Reißniet 4x6,3
25	521957	Bolt M4x12	Vis M4x12	Schraube M4x12
26	313251002104	Riveting nut M4	Ecrou-rivet M4	Nietmutter M4
27	PRI212002020	Bolt M5x16	Vis M5x16	Schraube M5x16
28	516832	Hinge for cover	Charnière	Aufhängung
29	PRI609000044	Shaft hinge 10x56 brass	Cheville en laiton 10x56	Bandbolzen 10x56 Messing
30	PRI611000018	SRV clamp	Agrafe	Befestigungsschelle
31	PRI250000009	Blind rivets 3,2x8 DIN 7337	Rivet 3,2x8 DIN 7337	Niet 3,2x8 DIN 7337
32	310934000006	Nut M6	Écrou M6	Mutter M6
33	PRI551000087	Label "SERVICE WARNING"West	Ecusson "Avertissement"	Schild "Servicewarning" West
33	548011099014	Label "SERVICE WARNING"East	Ecusson "Avertissement"	Schild "Servicewarning" Ost
34	PRI251000028	Screw 2,2x6,5 DIN 7S71A2	Vis 2,2x6,5 DIN 7S71A2	Selbstschneidschraube 2,2x6,5 DIN 7S71A2
35	PRI543000004	Plastic cover (with electronic timer MCB FC), valid only for USA	Couvercle plastique (met program. électronique MCB FC) USA	Kunststoffabdeckung (Elektronischer Steuertimer MCB FC) USA

Зип Общепит

vsezip.ru

+7(812)987-08-81

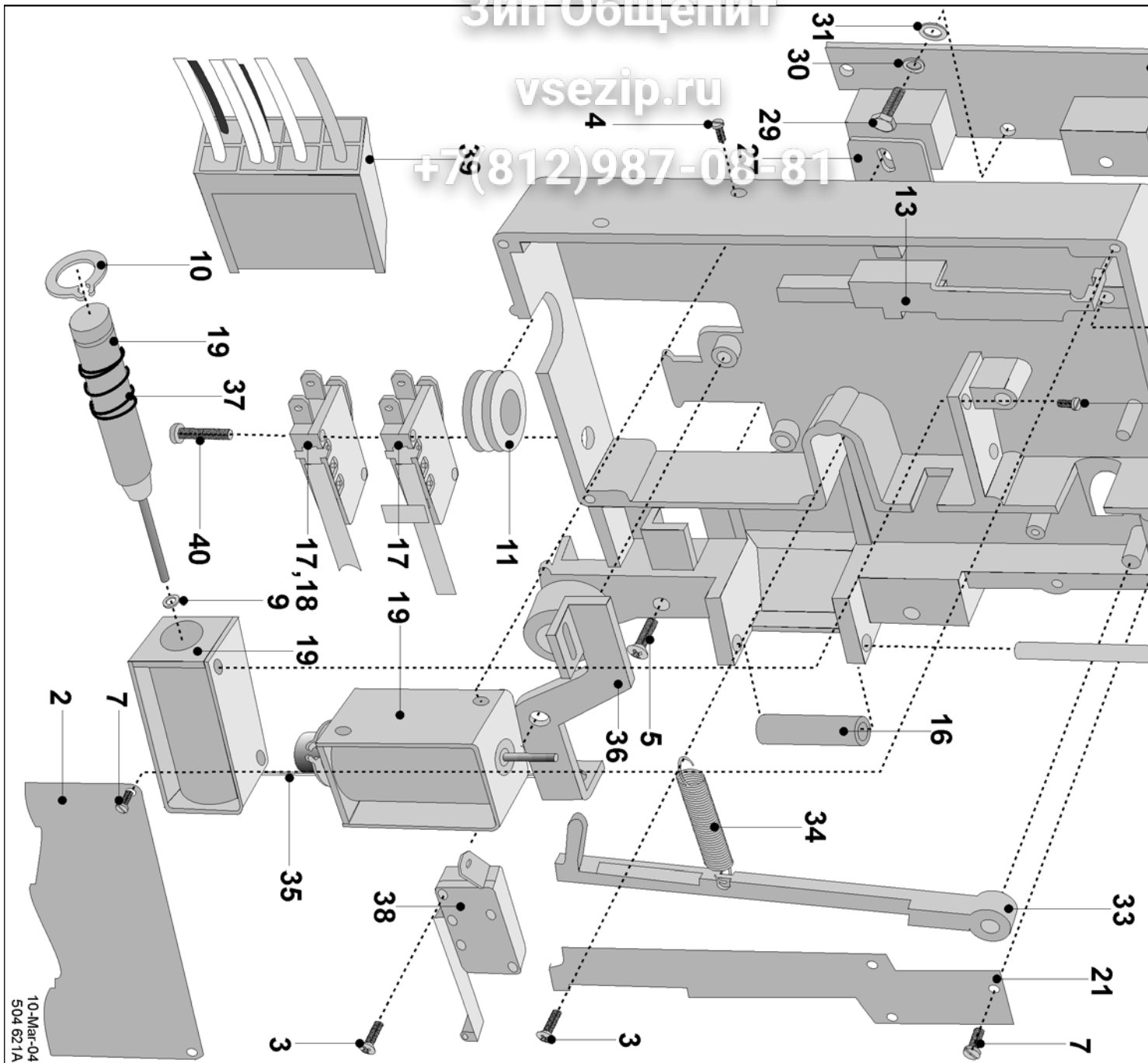

10-Mar-04
504 62 1A

Зип Общепит

N°	Code	Description	Designation	Bezeichnung
1	PRI610057077 PRI610060077 PRI610061077 PRI610056077	Complete door lock 220V 50/60Hz (with coin meter) Complete door lock 220V 50/60Hz (with electronic) Complete door lock 220V 50/60Hz (with card controller) Complete door lock 120V 60Hz	Serrure complète 220V 50/60Hz (monnayeur) Serrure complète 220V 50/60Hz (electronique) Serrure complète 220V 50/60Hz (à cartes) Serrure complète 120V 60Hz	Schloß komplett 220V 50/60Hz (mit Münzge Schloß komplett 220V 50/60Hz (mit Elektro Schloß kompl. 220V 50/60Hz (mit Kartenpro Schloß komplett 120V 60Hz
2	M07124000114	Protection plate - stainless steel	Couvre-boîte inox.	Abdeckblech - nichtrostend
3	309798500314	Bolt M3x14 DIN 7985A	Vis M3x14 DIN 7985A	Schraube M3x14 DIN 7985A
4	309798500306	Bolt M3x6 DIN 7985A	Vis M3x6 DIN 7985A	Schraube M3x6 DIN 7985A
5	309798524525	Bolt M5x25 stainless steel DIN 7985A	Vis M5x25 inox. DIN 7985A	Schraube M5x25 nichtrostend DIN 7985A
6	309084000408	Bolt M4x8 CK DIN 84A	Vis M4x8 CK DIN 84A	Schraube M4x8 CK DIN 84A
7	309963240306	Bolt M3x6 PK stainless steel ISO 2009	Vis M3x6 PK inox. ISO 2009	Schraube M3x6 PK nichtrostend ISO 2009
8	PRI346000003	Bimetal	Bimétal	Bimetal
9	PRI230000007	Washer 5,1x3,3x0,1	Rondelle 5,1x3,3x0,1	Unterlegscheibe 5,1x3,3x0,1
10	PRI242000013	Retaining ring G10	Rondelle de blocage G10	Sicherheitsring G10
11	PRI501000069	Cable passage	Traversée	Durchführung
13	PRI610000087	Small lock hook	Serrure	Schloßklinke klein
15	PRI610000090	Lock spindle 4x45	Cliquet 4x45	Sperre 4x45
16	PRI610000091	Lock tube 4x23,5	Rouleau 4x23,5	Zylinder 4x23,5
17	PRI610011077	Microswitch, valid for No.1 - PRI610060077	Micro-interrupteur, valable pour la position n° 1 - PRI610060077	Mikroschalter, gültig für Pos. Nr.1 - PRI61
17	102394	Microswitch, valid for pos. No.1 - PRI610056077,	Micro-interrupteur, valable pour la position n° 1 - PRI610056077, PRI610057077	Mikroschalter, gültig für Pos. Nr.1 - PRI610056077, PRI610057077
17	PRI610057077	PRI610057077	- PRI610056077, PRI610057077	- PRI610056077, PRI610057077
18	517503	Microswitch, valid for pos. No.1 - PRI610056077,	Micro-interrupteur, valable pour la position n° 1 - PRI610056077, PRI610057077	Mikroschalter, gültig für Pos. Nr.1 - PRI610056077, PRI610057077
18	PRI610012077	Coil	Bobine	Spule
19	PRI610008077	Coil	Bobine	Spule
21	PRI611000047	Leaf spring	Support	Federstütze
27	PRI610001122	Shim	Cale	Distanzunterlegscheibe
28	PRI610000086	Lock intermediate part	Appui	Schloßgrundlage
29	309933240612	Bolt M6x12 stainless steel	Vis inox. M6x12	Schraube M6x12 nichtrostend
30	311127000006	Spring lock washer 6	Rondelle elastique 6	Federunterlegscheibe 6
31	311125240006	Washer 14x8,6x1 stainless steel DIN 125 A2	Rondelle inox. 14x8,6x1 DIN 125 A2	Unterlegscheibe 14x8,6x1 nichtrostend DIN
32	PRI610000132	Door lock	Serrure	Schoß
33	PRI610000134	Locking handle part	Tige de commande	Abschlußzugstange
34	PRI611000048	Locking part spring	Ressort	Feder
35	PRI723000004	Emergency opening cord	Tirant de déblocage	Zugstange des Notöffners
36	PRI610000135	Emergency opening lever	Bras de commande	Zugstange
37	PRI611000050	Coil spring	Ressort bobine	Federspule
38	PRI610032077	Microswitch	Microrupteur	Mikroschalter
39	PRI351005116	Door lock wiring (with mechanical timer)	Bloc serrure (avec programmeur mecanique)	Schloßrangier (mit mechanischem Program
	RM4710001428	Door lock wiring (with electronic timer)	Bloc serrure (avec programmeur electronique)	Schloßrangier (mit Elektronischer Steuerun
	PRI351005129	Door lock wiring (with card controller)	Bloc serrure (à cartes)	Schloßrangier (mit Kartenprogrammator)
40	309798500325	Bolt M3x25	Vis M3x25	Schraube M3x25

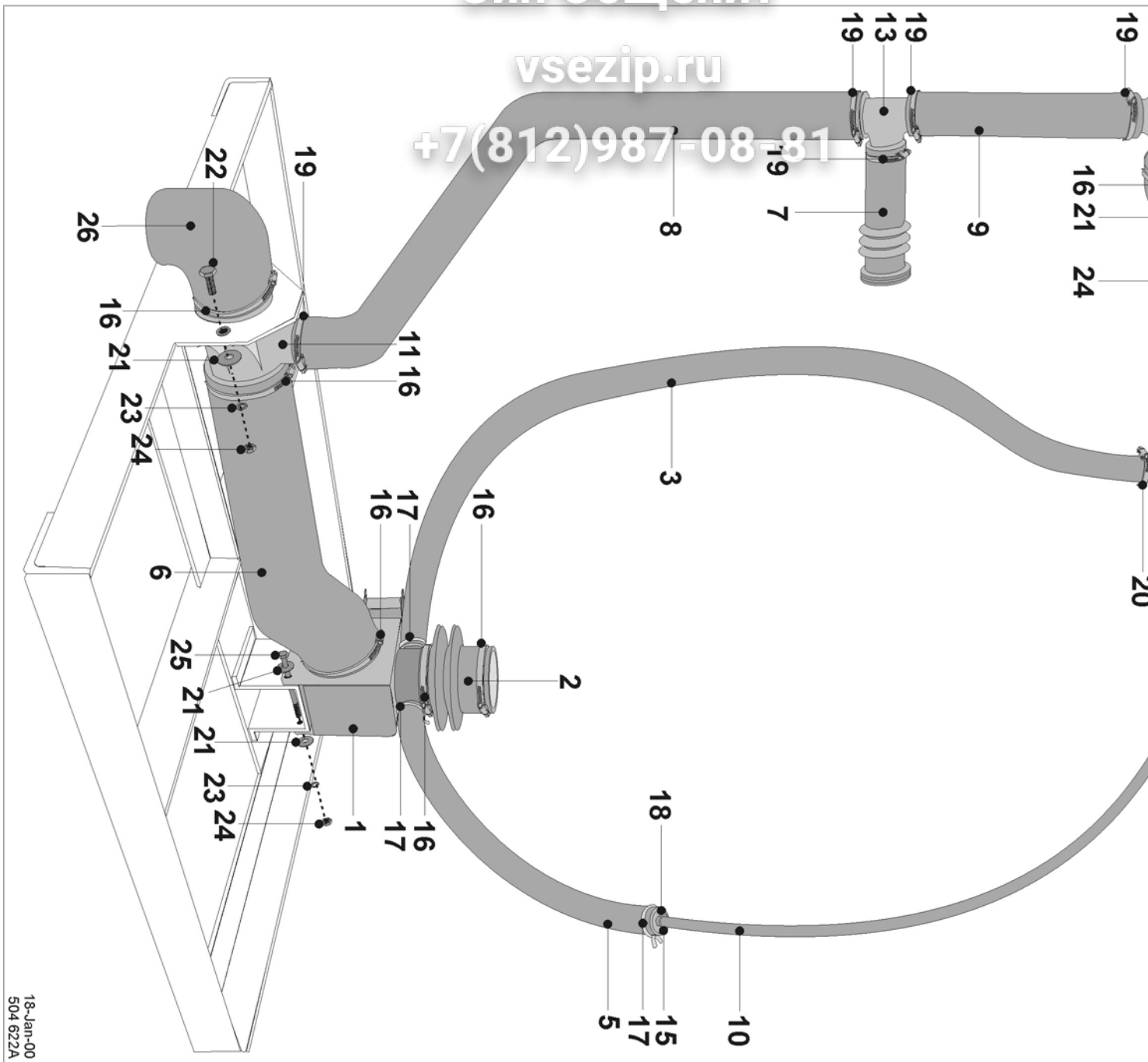

Зип Общепит

N°	Code	Description	Designation	Bezeichnung
1	PRI340055051	Outlet valve complete 50/60Hz	Soupape d'évacuation complète 50/60Hz	Ablassventil kompl. 50/60Hz
1	PRI340054051	Outlet valve chamber	Chambre de la soupape d'évacuation	Kammer Ablassventil
1	PRI340002051	Outlet valve motor	Moteur de la soupape d'évacuation	Motor Ablassventil
2	273124080161	Hose tub - outlet valve	Tuyau de vidange	Auslaßfallschlauch
3	PRI503002049	Hose outlet valve - soap hopper	Tuyau de savons liquides	Schlauch für flüssige Mittel
5	PRI503002049	Hose (30cm)	Tuyau d'air (30cm)	Luftfahllenschlauch (30cm)
6	PRI505000087	Drain hose (22kg-50lbs)	Tuyau d'évacuation (22kg-50lb)	Auslaßschlauch (22kg-50lb)
6	PRI505000091	Drain hose (16kg-35lbs)	Tuyau d'évacuation (16kg-35lb)	Auslaßschlauch (16kg-35lb)
7	PRI505000088	Hose back plate - air vent	Tuyau trop-plein	Überfallfallschlauch
8, 9	PRI505000090	Overflow hose	Tuyau trop-plein	Überfallschlauch
10	PRI540001003	Water level switch hose	Serpentin de l'interrupteur	Schlauch der Wasserspiegelschalters
11	PRI505000078	Air vent - drain T-part	Té	T-stück (Auslaß)
12	PRI505000089	Air vent - soap hopper hose	Tuyau de ventilation	Entlüftungsschlauch
13	PRI505000077	T-part overflow	Té	T-Stück
14	PRI240000021	Hose clamp 60-80	Collier 60-80	Schlauchspanne 60-80
15	PRI241000017	Clip A5,5	Bride A5,5	Spanne A5,5
16	PRI240000007	Hose clamp 70-90	Collier 70-90	Schlauchspanne 70-90
17	PRI241000006	Clip A17,5	Bride A17,5	Spanne A17,5
18	PRI503000027	Reducing part water level switch	Réduction de "piège" de l'air	Reduktion Luftfalle
19	PRI240000008	Hose clamp 32-50	Collier 32-50	Schlauchspanne 32-50
20	PRI240000003	Hose clamp 20-32	Collier 20-32	Schlauchspanne 20-32
21	311902100008	Washer 24x8,4x2	Rondelle 24x8,4x2	Unterlegscheibe 24x8,4x2
22	309933000820	Bolt M8x20	Vis M8x20	Schraube M8x20
23	311127000008	Spring lock washer M8	Rondelle élastique M8	Unterlegscheibe M8
24	310934800008	Nut M8	Écrou M8	Mutter M8
25	309931008120	Bolt M8x120	Vis M8x120	Schraube M8x120
26	519463	Drain elbow	Coude d'évacuation	Ablaßkniestück
27	311125000008	Washer 8,4	Rondelle 8,4	Unterlegscheibe 8,4
28	PRI503000028	Y Piece diam 5	Piece Y diamètre 5	Y-Stück ϕ 5

Зип Общепит

N°	Code	Description	Designation	Bezeichnung
1	521827	Rear bridge	Panneau arrière	Hintertafel
2	503108	Rear bridge (USA)	Panneau arrière (E.A.)	Hintertafel (USA)
3	PRI340030038	Three way valve 220V 50/60Hz	Vanne à 3 voies 220V 50/60Hz	Dreiwegventil 220V 50/60Hz
3	309084000410	Screw M4x10CK	Vis M4, 10CK	Schraube M4x10CK
4	311679824004	Lock washer external teeth M4	Rondelle à crans multiples M4	Unterlegscheibe M4
5	PRI240000002	Hose clamp 12-20 DIN 3017	Collier 12-20 DIN 3017	Schlauchspange 12-20 DIN 3017
6	PRI540000014	Inlet hose	Tuyau	Schlauch
	101745	Inlet hose, valid for water approval	Tuyau	Schlauch
7	PRI543000003	Button cover	Couvre-bouton	Tasterabdeckung
8	PRI350000045	Swivel	Traversée de câble	Stopfbuchsentülle
9	PRI348000095	Acceleration button	Bouton d'accélération	Akzellerationstaste
10	PRI348001096	Plug white	Couvre - bouton	Verblindung
11	PRI350001045	Swivel nut	Écrou	Mutter der Stopfbuchsentülle
12	309084000420	Screw M4x20	Vis M4x20	Selbstschneidschraube M4x20
13	PRI340020035	Two way valve 220V 50Hz/60Hz	Vanne à 2 voies 220V 50Hz/60Hz	2-Weg-Ventil 220V 50Hz/60Hz
	101833	Two way valve 220V 50Hz/60Hz, valid for water approval	Vanne à 2 voies 220V 50Hz/60Hz	2-Weg-Ventil 220V 50Hz/60Hz
14	510603	Terminal box	Réglette de bornes	Klemmleiste
15	503118	Cover	Abri	Abdeckung
16	309933240612	Screw M6x12	Vis M6x12	Selbstschneidschraube M6x12
17		Identification plate	Écusson de fabrication	Herstellerschild
18	PRI250000014	Blind rivets DIN 7337	Rivet DIN 7337	Niet DIN 7337
19	PRI401001020	Fuse holder	Porte-fusibles	Sicherungsschalter
20	PRI250000009	Blind rivet	Rivet blindé	Niet blind
24	PRI551002233	Sticker "ELECTRICITY WARNING", (west languages)	Écusson "Avertissement", la langue d'ouest	Schild "Achtung", Westsprache
	509608	Sticker "ELECTRICITY WARNING", (east languages)	Écusson "Avertissement", la langue d'est	Schild "Achtung", Ostsprache
27	PRI551001244	Index plate "Spin direction"	Plaque "Sens de rotation"	Schild Drehrichtung
28	548000002014	Index plate "Hot water"	Plaque "Eau chaude"	Schild "Warmes Wasser"
29	548000003014	Index plate "Cold hard water"	Plaque "Eau froide dure"	Schild "Hartes kaltes Wasser"
30	548000004014	Index plate "Cold soft water"	Plaque "Eau froide douce"	Schild "Weiches kaltes Wasser"
31	PRI551000231	Index plate pipe thread	Plaque vannes d'eaux	Schild der Wasserventile
33	PRI551002217	Sticker 1A 240V	Plaque fusibles 1A 240V	Sicherungsschild 1A 240V
	PRI551001217	Sticker 1A 400V	Plaque fusibles 1A 400V	Sicherungsschild 1A 400V
	PRI551003217	Sticker 2A 120V	Plaque fusibles 2A 120V	Sicherungsschild 2A 120V
34	345900025012	Plug liquid soap opening	Bouchon	Stopfbuchse
35	PRI505000064	Plug water inlet	Bouchon	Stopfbuchse
36	PRI614000093	Adapter for inch thread	Adapteur	Adapter
42	PRI426001217	Connection part 3/4" pipe thread brass	Nipple 3/4" - laiton	Einlage 3/4" Messing
43	PRI231000062	Washer 40x26,5x3	Rondelle 40x26,5x3	Unterlegscheibe 40x26,5x3
44	PRI426003217	Extension part pipe thread brass	Rallongement 3/4" laiton	Verlängerung 3/4" Messing
45	PRI426001107	T - parts 3/4" - pipe thread brass	Té - 3/4" laiton	T-Stück 3/4" Messing
46	PRI505000055	Connection hose 3/4"	Tuyau de remplissage 3/4"	Einlassschlauch 3/4"
	PRI505006055	Connection hose	Tuyau de remplissage	Einlassschlauch
	101621	Connection hose, valid for water approval	Tuyau de remplissage	Einlassschlauch
48	PRI350001056	Swivel nut PG16	Écrou PG16	Mutter der Stopfbuchsentülle PG16

Зип Общепит

vsezip.ru

+7(812)987-08-81

Зип Ощепит

N°	Code	Description	Designation	Bezeichnung
49	PRI551000263	Sticker of terminal board	Plaque bornes	Klemmleistenschild
50	311125240006	Washer M6	Rondelle M6	Unterlegscheibe M6
51	PRI225000004	Nut M6	Écrou M6 laiton	Mutter M6 Messing
52	510655	Electro-insulation foil	Feuille elect. isolante	Elektroisolier-Folie
54	PRI350000056	Swivel	Traversee de câble	Stopfbuchsentülle
55	PRI404000095	Controler	Organe de commande	Steuerelement
56	PRI350001047	Swivel nut	Écrou	Mutter der Stopfbuchsentülle
57	PRI350000047	Swivel	Traversee de câble	Stopfbuchsentülle
58	345900032132	Plug 23	Bouchon 23	Stopfbuchse 23
59	PRI350015007	Terminal boards 2 poles	Bornes de connexion 2pol.	2-poliges Klemmbrett
61	PRI401003020	Fuse holder	Porte - fusible	Sicherungsschalter
62	345805163032	Fuse 1A 6,3x32	Fusible 1A 6,3x32	Sicherung 1A 6,3x32
	344000010000	Fuse 1A 5x20	Fusible 1A 5x20	Sicherung 1A 5x20
	PRI401000021	Fuse 2A 5x20	Fusible 2A 5x20	Sicherung 2A 5x20
63	PRI401022021	Fuse 0,5A	Fusible 0,5A	Sicherung 0,5A
64	510602	Supply label	Étiquette d'alimentation	Speisungsschild
65	548011123014	Index plate "Flash"	Plaque "Parafoudre"	Schild "Blitz"
66	PRI551000047	Index plate "Warning, outlet"	Plaque "Attention, souffle"	Schild "Achtung, Abpuff"
67	PRI551000263	PE sticker	Écusson PE	Schild PE
68	510601	Phase sticker	Étiquette de sélection de tension	Schild Spannungswahl
69	PRI226000003	Nut M4	Écrou M4	Mutter M4
70	PRI245000019	Lock washer external teeth M6	Rondelle à crans multiples M6	Unterlegscheibe M6
71	309084100416	Screw M6x25 brass	Vis M6x25 laiton	Schraube M6x25 Messing
72	PRI520001009	Rubber ring	Joint	Gummiring
74	PRI340004030	Filter	Tamis	Filter
75	PRI407002123	Terminal board	Bornes de connexion	Klemmbrett
76	PRI426000142	T-part 3/4"	Té 3/4"	T-Stück 3/4"
77	PRI404000097	Main switch 20A	Interrupteur général 20A	Hauptschalter 20A
	PRI404000098	Main switch 32A	Interrupteur général 32A	Hauptschalter 32A
	PRI404000099	Main switch 63A	Interrupteur général 63A	Hauptschalter 63A
	PRI404000100	Main switch 80A	Interrupteur général 80A	Hauptschalter 80A
79	345900215120	Plug	Bouchon	Stopfbuchse

Зип Общепит

N°	Code	Description	Designation	Bezeichnung
1	PRI325000025 PRI325000010 PRI325000024 PRI325000033	Motor CV 132 E 230/400V III 50Hz (16kg-35lbs) Motor CV 132 F 230/400V III 50Hz (22kg-50lbs) Motor CVE 132 H 208/240V Mono 60Hz Motor CV 132 E 208/240V III 60Hz (16kg-35lbs)	Motor CV 132 E 230/400V III 50Hz (16kg-35lb) Moteur CV 132 F 230/400V III 50Hz (22kg-50lb) Moteur CVE 132 H 208/240V Mono 60Hz Moteur CV 132 E 208/240V III 60Hz (16kg-35lb)	Motor CV 132 E 230/400V III 50Hz (16kg-35lb) Motor CV 132 F 230/400V III 50Hz (22kg-50lb) Motor CVE 132 H 208/240V mono 60Hz Motor CV 132 E 208/240V III 60Hz (16kg-35lb)
	PRI325001025 101607 101608	Motor CV 132 F 208/240V III 60Hz (22kg-50lbs) Motor 200V 50Hz (16kg-35lbs) Motor 200V 50Hz (22kg-50lbs)	Moteur CV 132 F 208/240V III 60Hz (22kg-50lb) Moteur 200V 50Hz (16kg-35lbs) Moteur 200V 50Hz (22kg-50lbs)	Motor CV 132 F 208/240V III 60Hz (22kg-50lb) Motor 200V 50Hz (16kg-35lbs) Motor 200V 50Hz (22kg-50lbs)
2	R16100010814	Sliding ring motor shaft	Bague de blocage	Sicherungsring
3	PRI606000088	V-pulley 63 XPZ 50Hz	Poulie 63 XPZ 50Hz	Riemenscheibe 63 XPZ 50Hz
4	PRI606000089	V-pulley 53 XPZ 60Hz	Poulie 53 XPZ 60Hz	Riemenscheibe 53 XPZ 60Hz
5	PRI609002053 R22100010714	Tolerance ring, (22kg-50lbs) Motor shaft (22kg-50lbs)	Douille d'écartement, (22kg-50lb) Axe moteur (22kg-50lb)	Düstanzhülse, (22kg-50lb) Motorzapfen (22kg-50lb)
	R16100010714 R16100012014	Motor shaft (16kg-35lbs) Motor pin sleeve	Axe moteur (16kg-35lb) Bague d'axe moteur (16kg-35lb)	Motorzapfen (16kg-35lb) Hülse (16kg-35lb)
6	PRI158010201	Belt tentioner	Support	Halter der Motorabdeckung
7	315160205013	Motor spring	Ressort	Motorfeder
8	PRI606013050	Socket key hole with screw (16kg-35lbs)	Douille + vis (16kg-35lb)	Gehäuse Riemenscheibe + Schrauben (16kg-35lb)
9	PRI609010153	Washer 90x10 DIN 7093 (22kg-50lbs)	Rondelle 90x10 DIN 7093 (22kg-50lb)	Unterlegscheibe 90x10 DIN 7093 (22kg-50lb)
10	PRI231000040 309933001235	Washer 30x13x6 (16kg-35lbs) Screw M12x35	Rondelle 30x13x6 (16kg-35lb) Vis M12x35	Unterlegscheibe 30x13x6 DIN 7093 (16kg-35lb) Schraube M12x35
11	PRI606000086	V-pulley 450 (16kg-35lbs)	Poulie 450 (16kg-35lb)	Riemenscheibe 450 (16kg-35lb)
	PRI606000087	V-pulley 450 (22kg-50lbs)	Poulie 450 (22kg-50lb)	Riemenscheibe 450 (22kg-50lb)
12	R16100011913	Protection shield motor	Capot moteur	Motorabdeckung
14	PRI607000072	V-belt XPZx1950	Courroie XPZx1950	Riemen XPZx1950
15	PRI252000003	Tongue 10x8x60 DIN 6885	Languette 10x8x60 DIN 6885	Feder 10x8x60 DIN 6885
16	309916450810	Screw M8x10	Vis M8x10	Schraube M8x10
17	309916000606	Screw M6x6	Vis M6x6	Schraube M6x6
18	PRI325010024	Suspension rubber motor	Bague	Motorhülse
19	311125000013	Washer 24x13x2,5	Rondelle 24x13x2,5	Unterlegscheibe 24x13x2,5
20	309933001450	Screw M14x50 (22kg-50lbs)	Vis M14x50 (22kg-50lb)	Schraube M14x50 (22kg-50lb)
21	309933000825	Screw M8x25	Vis M8x25	Schraube M8x25
22	311127000008	Spring lock washer M8	Rondelle élastique M8	Unterlegscheibe M8
23	310934000008	Nut M8	Écrou M8	Mutter M8
28	309933001270	Screw M8x70	Vis M8x70	Schraube M8x70
29	311125000008	Washer 8,4	Rondelle 8,4	Unterlegscheibe 8,4
30	309084000316	Screw M3 x 16	Vis M3x16	Schraube M3x16
31	310934240003	Nut M3	Écrou M3	Mutter M3
32	311679824003	Washer M3	Rondelle M3	Unterlegscheibe M3

Зип Общепит

N°	Code	Description	Designation	Bezeichnung
1	PRI610120077	Rectifier bridge	Redresseur	Gleichrichter
2	PRI341000034	Condenser 25mF	Condensateur 25mF	Kondensator 25mF
	PRI341000056	Condenser 60mF	Condensateur 60mF	Kondensator 60mF
	PRI341000059	Condenser 100mF	Condensateur 100mF	Kondensator 100mF
3	PRI326002004	Holder	Porte-reuesseur	Gleichrichterhalter
4	514038	Contacteur	Contacteur	Schalterschütz
	514039	Contacteur	Contacteur	Schalterschütz
5	514038	Contacteur	Contacteur	Schalterschütz
	514042	Contacteur	Contacteur	Schalterschütz
	PRI345002019	Contacteur	Contacteur	Schalterschütz
	PRI345001019	Contacteur	Contacteur	Schalterschütz
6	PRI345002045	Auxiliary contact	Coupleur	Schalteinheit
7	PRI345000038	Thermal overload relay 9-13A	Relais surintensité 9-13A	Überstromrelais 9-13A
	514030	Thermal overload relay 4-6A	Relais surintensité 4-6A	Überstromrelais 4-6A
	514031	Thermal overload relay 5,5-8A	Relais surintensité 5,5-8A	Überstromrelais 5,5-8A
	514032	Thermal overload relay 7-10A	Relais surintensité 7-10A	Überstromrelais 7-10A
	514092	Thermal overload relay 9-13A	Relais surintensité 9-13A	Überstromrelais 9-13A
9	PRI343000057	Reverser, (mechanical, card programmer)	Programmator reversible, (program. mecanique, à cartes)	Reversierungsprogrammator (mechanischem, -Kar
10	PRI340000077	Water level switch, (mechanical, card programmer)	Interrupteur, (program. mecanique, à cartes)	Wasserspiegelschalter (mechanischem, -Kar
	PRI340001075	Water level switch eco levels, (mechanical, card programmer)	Interrupteur économique, (program. mecanique, à cartes)	Wasserspiegelschalter eco (mechanischem, -Kar
11	PRI340001012	Thermostat 4 temperatures, (mechanical programmer)	Thermostat à 4 températures (program. mecanique)	4-temperatur Thermostat (mechanischem Pr
13	PRI350015007	Terminal board 6-poles	Bornes de connexion 6pol.	6-poliges Klemmbrett
	PRI350010044	Terminal board 4-poles	Bornes de connexion 4pol.	4-poliges Klemmbrett
14	PRI348000097	Change over contact prewash-no prewash, (mechanical programmer)	Commutateur pré lavage (program. mecanique)	Umschalter Vorwaschen (mechanischem P
	100388	Programming switch, (Easy Control)	Commutateur de programmation, (Easy Control)	Programmierschalter, (Easy Control)
15	PRI350012007	Isolation paper	Papier isolant	Isolationspapier
17	PRI501000071	Rubber ring 25	Traversée 25	Durchführung 25
18	PRI551026250	Label liquid soap	Plaque savons liquides	Schild für flüssige Waschmittel
19	309084000410	Bolt M4x10	Vis M4x10	Schraube M4x10
20	311679824004	Lock washer external teeth M4	Rondelle à crans multiples M4	Unterlegscheibe M4
21	309084000416	Bolt M4x16	Vis M4x16	Schraube M4x16
22	310934000004	Nut M4	Écrou M4	Mutter M4
23	514051	Mechanical lock device	Blocage mécanique contacteurs	Mech. Blockierung des Schalterschützes
24	309933000406	Bolt M4x6	Vis M4x6	Schraube M4x6
25	309933100625	Bolt M6x25 brass	Vis M6x25 laiton	Schraube M6x25 Messing
26	310934100006	Nut M6 brass	Écrou M6 laiton	Mutter M6 Messing
27	311679824006	Lock washer external teeth M6	Rondelle à crans multiples M6	Unterlegscheibe M6
28	PRI350010044	4-poles terminal board, (Easy Control)	Plaque à bornes - 4 poles, (Easy Control)	Klemmleiste 4-polig, (Easy Control)
	PRI350012007	Isolated paper brown	Isolant (en papier)	Isolierpapier
29	PRI409000013	Transformer 100VA	Transformateur 100VA	Transformator 100VA
30	PRI350020007	Connector	Boîte de connexion	Klemmbrett
32	PRI551002233	Sticker "ELECTRICITY WARNING", (west languages)	Écusson "Avertissement", la langue d'ouest	Schild "Achtung", Westsprache
	509608	Sticker "ELECTRICITY WARNING", (east languages)	Écusson "Avertissement", la langue d'est	Schild "Achtung", Ostsprache
33	PRI345034026	Buzzer, (card programmer)	Sonnerie, (program. à cartes)	Brummer (Karten Program.)

Зип Общепит

vsezip.ru

+7(812)987-08-81

Зип Общепит

N°	Code	Description	Designation	Bezeichnung
1	PRI165010113	Complete assembled tub (16kg-35lbs)	Cuve complète (16kg-35lb)	Außere Trommel komplett (16kg-35lb)
1	PRI165010112	Complete assembled tub (22kg-50lbs)	Cuve complète (22kg-50lb)	Außere Trommel komplett (22kg-50lb)
2	515282	Drum + shaft (16kg-35lbs)	Tambour + axe (16kg-35lb)	Innentrommel + Welle (16kg-35lb)
2	515283	Drum + shaft (22kg-50lbs)	Tambour + axe (22kg-50lb)	Innentrommel + Welle (22kg-50lb)
3	R16103000011	Tub (16kg-35lbs)	Cuve (16kg-35lb)	Außentrommel (16kg-35lb-Typ)
3	R22103000011	Tub (22kg-50lbs)	Cuve (22kg-50lb)	Außentrommel (22kg-50lb)
4	PRI158018030	Base plate stainless steel (16kg-35lbs)	Flanc arrière - inox (16kg-35lb)	Hintere Stirn nichtrostend (16kg-35lb)
4	PRI158019030	Base plate stainless steel with steam hole (16kg-35lbs)	Flanc arrière avec trous pour vapeur (16kg-35lb)	Hintere Stirn für Dampf nichtrostend (16kg-35lb)
4	PRI158020030	Base plate stainless steel without holes (16kg-35lbs)	Flanc arrière - pour résistance - inox (16kg-35lb)	Hintere Stirn ohne Öffnungen für Heizkörper (16kg-35lb)
4	PRI158001030	Base plate stainless steel (22kg-50lbs)	Flanc arrière - inox (22kg-50lb)	Hintere Stirn nichtrostend (22kg-50lb)
4	PRI158002030	Base plate stainless steel with steam hole (22kg-50lbs)	Flanc arrière avec trous pour vapeur (22kg-50lb)	Hintere Stirn für Dampf nichtrostend (22kg-50lb)
4	PRI158003030	Base plate stainless steel without holes (22kg-50lbs)	Flanc arrière - pour résistance - inox (22kg-50lb)	Hintere Stirn ohne Öffnungen für Heizkörper (22kg-50lb)
5	PRI158021029	Base plate iron (16kg-35lbs)	Renfort (16kg-35lb)	Versteifung der hinteren Stirn (16kg-35lb)
5	PRI158022029	Base plate iron (22kg-50lbs)	Renfort (22kg-50lb)	Versteifung der hinteren Stirn (22kg-50lb)
5	514853	Base plate iron 16kg, valid for frequency drive	Renfort (16kg-35lb)	Versteifung der hinteren Stirn (16kg), gültig für Frequenzantrieb
5	514854	Base plate iron 22kg, valid for frequency drive	Renfort (22kg-50lb)	Versteifung der hinteren Stirn (22kg), gültig für Frequenzantrieb
6	R16100010513	Ring 24 holes (16kg-35lbs)	Cerceau - 24 trous de vis (16kg-35lb)	Dichtungsring - 24 Öffnungen (16kg-35lb)
7	PRI163002017	Ornamental plate for handle round door	Feuille du côté frontal, valable pour le programmeur mécanique	Folie vordere Stirnseite, gültig für mechanischen Motor
7	500185	Ornamental plate for handle square door	Feuille du côté frontal, valable pour le type à portière à angles	Folie vordere Stirnseite, gültig für Ausführung mit Eckportiere
7	517492	Ornamental plate for handle round door, valid for electronic timer	Feuille du côté frontal, valable pour le programmeur électronique	Folie vordere Stirnseite, gültig für elektronischen Motor
8	PRI505011024	Rubber 24 holes	Joint - 24 trous de vis	Rubber 24 Öffnungen
9	PRI610030073	Microswitch hinge, valid for export USA	Microrupteur	Mikroschalter
11	PRI342000028	Heating element 3000W, l=265mm	Résistance 3000W, l=265mm	Heizkörper 3000W, l=265mm
11	PRI342030027	Heating element 4000W, l=470mm	Résistance 4000W, l=470mm	Heizkörper 4000W, l=470mm
11	PRI342000032	Heating element 6000W, l=470mm	Résistance 6000W, l=470mm	Heizkörper 6000W, l=470mm
12	PRI342001016	Plug for heating element hole	Bouchon de résistance	Stopfbuchse der Heizkörper
14	PRI340015019	Temperature sensor	Sonde thermostat	Thermostatgeber
14	PRI614000047	Holder thermostat sensor	Guide sonde thermostat	Durchführung des Thermostatgebers
15	PRI524000001	Seal ring	Bague de joint	Dichtungsring
16	PRI185022015	Steam injector low pressure (16kg-35lbs)	Injecteur à vapeur pour basse pression (16kg-35lb)	Dampfinjektor für Niederdruckdampf (16kg-35lb)
16	PRI185025015	Steam injector low pressure (22kg-50lbs)	Injecteur à vapeur pour basse pression (22kg-50lb)	Dampfinjektor für Niederdruckdampf (22kg-50lb)
16	PRI185021015	Steam injector high pressure (16kg-35lbs)	Injecteur à vapeur pour haute pression (16kg-35lb)	Dampfinjektor für Hochdruckdampf (16kg-35lb)
16	PRI185024015	Steam injector high pressure (22kg-50lbs)	Injecteur à vapeur pour haute pression (22kg-50lb)	Dampfinjektor für Hochdruckdampf (22kg-50lb)
17	PRI614000048	Sensor bushing nut	Écrou du traverse de détecteur	Mutter Fühlerdurchführung
22	310985000008	Self locking nut M8	Écrou arêteoir M8	Selbstsichernde Mutter M8
27	311125000008	Washer 16x8,4x1,6 (22kg-50lbs)	Rondelle 16x8,4x1,6 (22kg-50lb)	Unterlegscheibe 16x8,4x1,6 (22kg-50lb)
28	309966240408	Screw M4x8	Vis M4x8	Schraube M4x8
29	PRI247000003	Washer 5	Rondelle 5	Unterlegscheibe 5
30	PRI505000058	Protecting rubber	Garniture profilée	Profildichtung
31	309933000845	Screw M8x45	Vis M8x45	Schraube M8x45
32	PRI211000024	Screw M4x16, valid for export USA	Vis M4x16	Schraube M4x16, gültig lediglich für USA
33	PRI226000003	Nut M4, valid for export USA	Écrou M4	Mutter M4, gültig lediglich für USA
34	PRI240000027	Fixation plate motor wiring	Support	Halter der Motoranbringung

Зип Общепит

vsezip.ru

+7(812)987-08-81

Зип Ощепит

N°	Code	Description	Designation	Bezeichnung
35	319428320504	Elbow 1/2"	Coude 1/2"	Knie 1/2"
38	319428320704	Elbow 1/2"	Coude 1/2"	Knie 1/2"
39	R16112000724	Connection tube 1/2" - 27cm (16kg-35lbs)	Tube 1/2" - 27cm (16kg-35lb)	Röhre 1/2" - 27cm (16kg-35lb)
39	R22112000724	Connection tube 1/2" - 35cm (22kg-50lbs)	Tube 1/2" - 35cm (22kg-50lb)	Röhre 1/2" - 35cm (22kg-50lb)
40	514164	Steam valve 1/2" with coil	Soupape à vapeur 1/2" avec bobine	Dampfventil 1/2" mit Spule
40	514165	Steam valve 1/2" without coil, valid for export USA	Soupape à vapeur 1/2" sans bobine, valable uniquement pour les USA	Dampfventil 1/2" ohne Spule, gültig nur für USA
40	514167	Coil, valid for export USA	Bobine, valable uniquement pour les USA	Spule, gültig nur für USA
41	230110001715	Yoke	Étrier	Bügel
42	310934000006	Nut M6 DIN934	Écrou M6 DIN934	Mutter M6 DIN934
43	311125000006	Washer 6 DIN125	Rondelle 6 DIN125	Unterlegscheibe 6 DIN125
44	311127000006	Spring lock washer 6 DIN127	Rondelle élastique 6 DIN127	Unterlegscheibe federn 6 DIN127
45	R35100010514	Plug 6 diam.	Bouchon diamètre 6	Stopfen Ø 6
46	405054120215	Steam filter	Filtre à vapeur	Dampffilter
47	319428324012	Adaptor	Adapteur	Adapter

Зип Общепит

vsezip.ru

+7(812)987-08-81

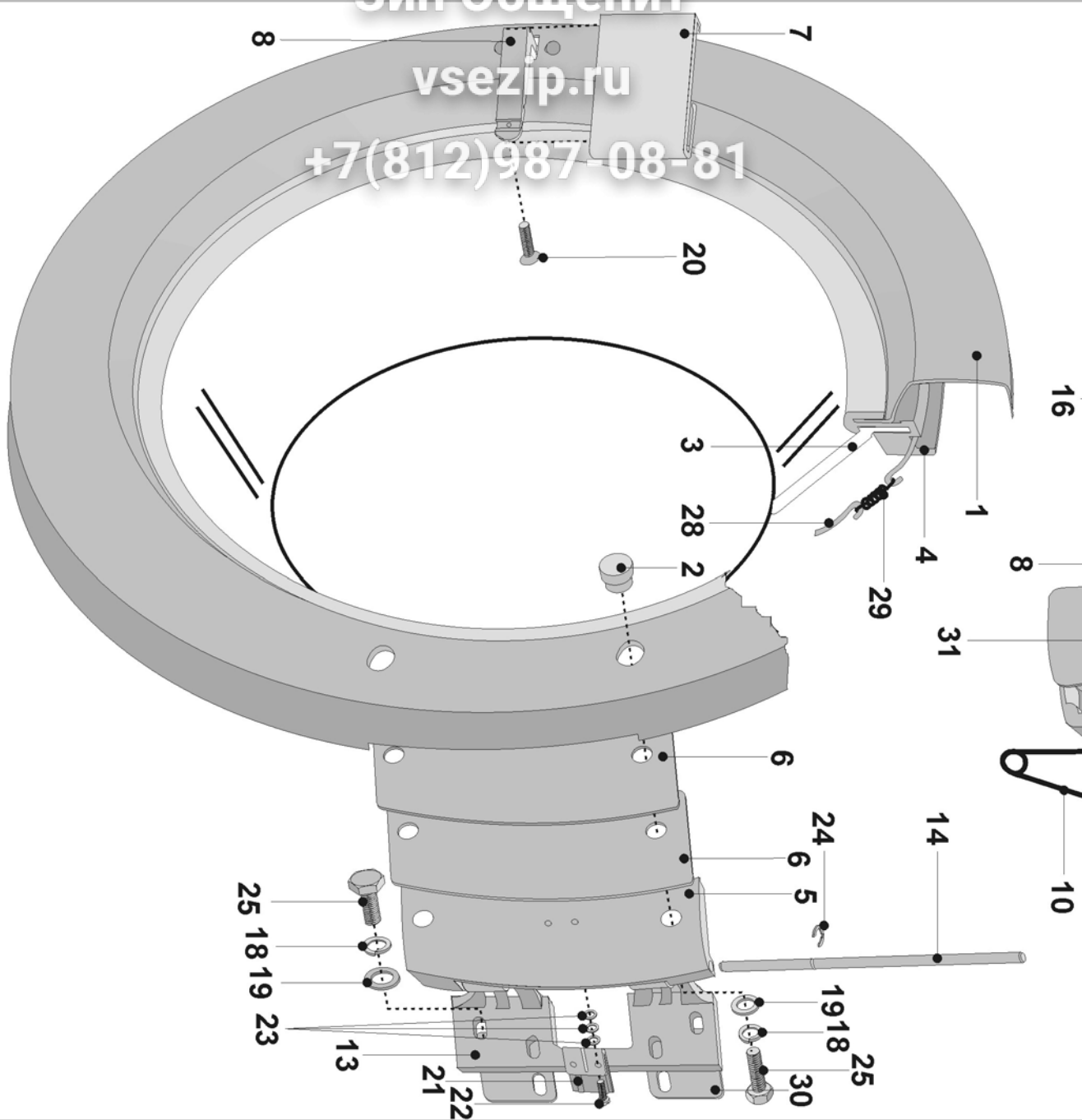

Зип Ощепит

N°	Code	Description	Designation	Bezeichnung
1	500160	Door round	Porte ronde	runde Tür
1	500189	Door square	Porte angulaire	eckige Tür
2	PRI609000107	Ornamental nut stainless steel	Écrou inox	Mutter nichtrostend
3	PRI505000040	Door glass	Verre	Türglas
4	PRI505000041	Door glass gasket	Garniture d'étanchéité	Dichtung des Türglases
5	PRI610000124	Hinge loose part round door	Suspension hublot porte ronde	Türband runde Tür
5	PRI610010126	Hinge loose part square door	Suspension hublot porte angulaire	Türband eckige Tür
6	514941	Shim loose part round door	Grand rondelle porte ronde	Türbandunterlegscheibe, runde Tür
6	504841	Shim loose part square door	Cale de limite porte angulaire	Türbandunterlegscheibe, eckige Tür
7	PRI610011086	Handle shining, applicable for round door	Main courante brillante, porte ronde	Glanzhandgriff, runde Tür
7	510605	Handle black without logo, applicable for square door	Manivelle noire la partie avec le logo	Handgriff schwarz ohne Logo, gültig für eckige Tür
7	510604	Handle black with logo, valid for export USA	Manivelle noire la partie (USA)	Handgriff schwarz mit Logo, mit Logo USA
8	100386	Handle lever for handle, applicable for round door	Manivelle de la main courante, porte ronde	Türklinke, gültig für runde Tür
8	501513	Handle lever for black handle without logo, applicable for square door	Manivelle de la main courante noire, porte angulaire	Türklinke schwarz ohne Logo, gültig für eckige Tür
9	PRI610000089	Shaft handle	Cheville	Klinkezapfen
10	PRI611000045	Spring handle	Ressort poignée	Klinkefeder
11	PRI247010013	Fixing washer 2,4 DIN 933	Rondelle de blocage 2,4 DIN 933	Sicherungsunterlage 2,4 DIN 933
13	PRI610000122	Hinge fixed side	Suspension rigide	Feste Türaufhängung
14	PRI609000106	Shaft hinge	Cheville	Türzapfen
15	PRI610000083	Holder handle	Plaque de suspension	Aufhängungsplatte
16	PRI212000033	Screw M6x26 stainless steel	Vis inox M6x26	Schraube M6x26 nichtrostend
17	310934240006	Nut M6 stainless steel	Écrou inox M6	Mutter M6 nichtrostend
18	311127240006	Spring lock washer M6	Rondelle élastique M6	Unterlegscheibe M6
19	311125240006	Washer 12x6,4x1,6	Rondelle 12x6,4x1,6	Unterlegscheibe 12x6,4x1,6
20	309966240408	Screw M4x8 stainless steel	Vis inox M4x8	Schraube M4x8 nichtrostend
21	PRI185004004	Activating plate microswitch	Dispositif d'arrêt microprocesseur	Mikroschalteranschlag
22	309084240410	Screw M4x10 stainless steel	Vis inox M4x10	Schraube M4x10 nichtrostend
23	PRI231000002	Washer 10x5,3x1	Rondelle 10x5,3x1	Unterlegscheibe 10x5,3x1
24	PRI242000006	Retaining ring 8	Anneau de blocage 8	Sicherungsring 8
25	309933240620	Screw M6x20 stainless steel	Vis inox M6x20	Schraube M6x20 nichtrostend
28	PRI184000024	Tension ring door seal	Agrafe	Türspange
29	PRI611010075	Spring	Ressort	Feder
30	PRI610011026	Hinge shim	Cale de compensation de la suspension	Ausgleichscheibe Türband
31	504842	Holder handle shim	Cale de compensation de la suspension de main courante	Ausgleichscheibe Handgriff-halter

Зип Общепит

vsezip.ru

+7(812)987-08-81



16 kg
35 lbs

22 kg
50 lbs

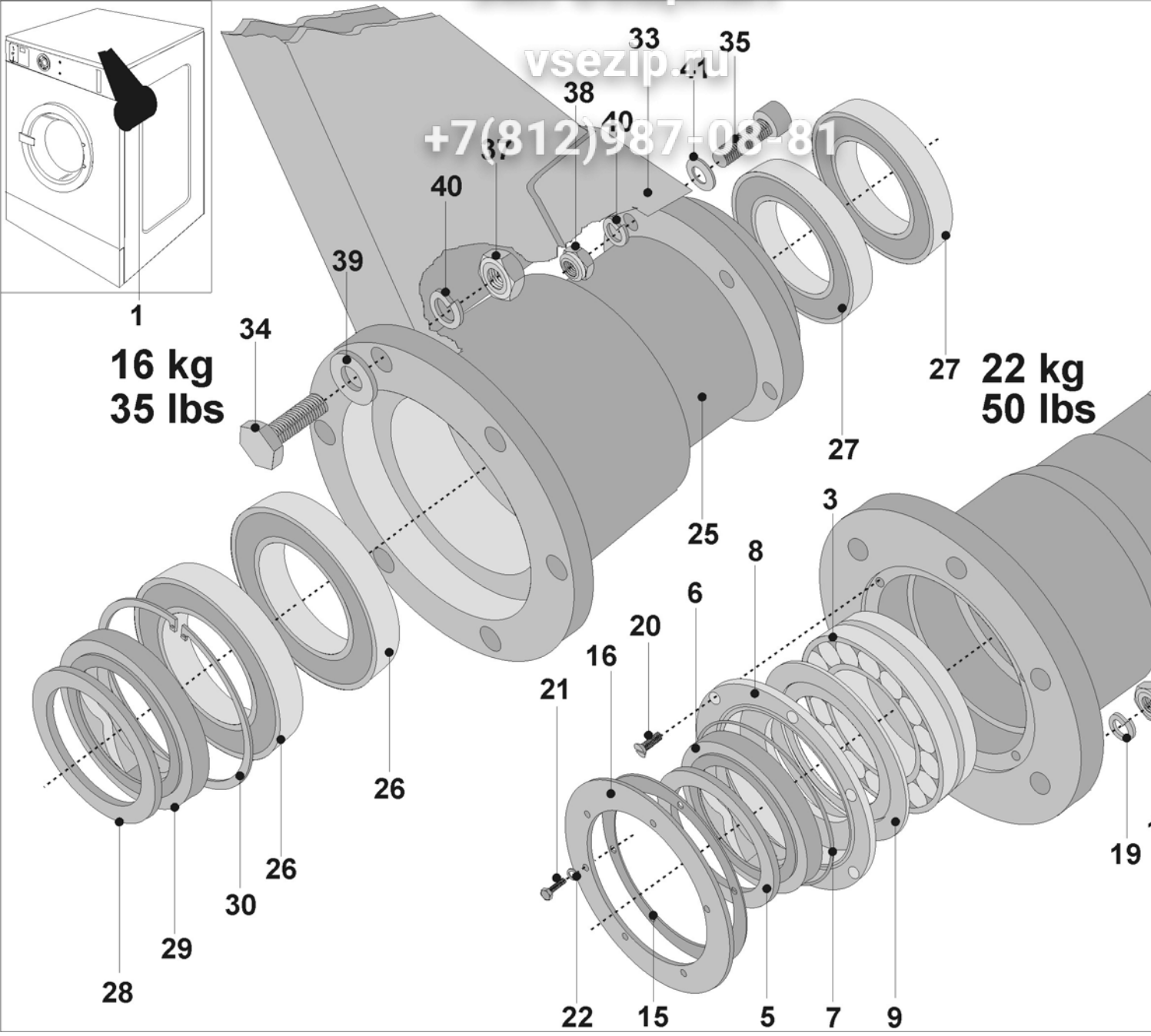

Зип Общепит

N°	Code	Description	Designation	Bezeichnung
1	R1610500011	Trunnion (16kg-35lbs)	Moyeu complet (16kg-35lb)	Nabe komplette (16kg-35lb)
2	R2210500011	Trunnion (22kg-50lbs)	Moyeu complet (22kg-50lb)	Nabe komplette (22kg-50lb)
2	R22105000113	Bearing house (22kg-50lbs)	Moyeu (22kg-50lb)	Nabe (22kg-50lb)
3	PRI608000066	Bearing, (22kg-50lbs)	Roulement, (22kg-50lb)	Lager, (22kg-50lb)
4	PRI608000065	Bearing, (22kg-50lbs)	Roulement, (22kg-50lb)	Lager, (22kg-50lb)
5	PRI530000030	Counter ring (22kg-50lbs)	Bague de l'axe (22kg-50lb)	Lager (22kg-50lb)
6	PRI530000023	Axial seal (22kg-50lbs)	Joint axial (22kg-50lb)	Axialdichtung (22kg-50lb)
7	PRI520000022	O-ring (22kg-50lbs)	Anneau (22kg-50lb)	O-Ring (22kg-50lb)
8	R22105000513	Holder axial seal (22kg-50lb)	Coupelle de joint (22kg-50lb)	Dichtungsschale (22kg-50lb)
9	510636	Ring (22kg-50lbs)	Anneau (22kg-50lb)	Ring (22kg-50lb)
10	R22107000011	Tension rod (22kg-50lbs)	Bras entier (22kg-50lb)	Komplettes Arm (22kg-50lb)
11	R22105000614	Distance ring stainless steel (22kg-50lbs)	Bague d'écartement - inox (22kg-50lb)	Distanzring nichtrostend (22kg-50lb)
12	R22105000714	Bushing ring - brass (22kg-50lbs)	Bague - laiton (22kg-50lb)	Ring Messing (22kg-50lb)
13	PRI530000027	Axial seal (22kg-50lbs)	Joint (22kg-50lb)	Dichtung (22kg-50lb)
14	PRI158001035	Holder axial seal (22kg-50lbs)	Chapeau de coussinet gufero (22kg-50lb)	Guferoabdeckung (22kg-50lb)
15	PRI505000042	Rubber seal (22kg-50lbs)	Joint (22kg-50lb)	Dichtung (22kg-50lb)
16	PRI615004030	Fixating ring (22kg-50lbs)	Tôle de pression (22kg-50lb)	Andrückblech nichtrostend (22kg-50lb)
17	309933001425	Screw M14x25 (22kg-50lbs)	Vis M14x25 (22kg-50lb)	Schraube M14x25 (22kg-50lb)
18	310934000014	Nut M14 (22kg-50lbs)	Écrou M14 (22kg-50lb)	Mutter M14 (22kg-50lb)
19	311127000014	Spring lock washer M14	Rondelle élastique M14	Unterlegscheibe M14
20	PRI212001015	Screw M4x10 stainless steel DIN 963A2 (22kg-50lbs)	Vis inox M4x10 DIN 963A2 (22kg-50lb)	Schraube M4x10 nichtrostend (22kg-50lb)
21	309933240612	Screw M6x12 - stainless steel (22kg-50lbs)	Vis inox M6x12 (22kg-50lb)	Schraube M6x12 nichtrostend (22kg-50lb)
22	PRI230000005	Seal ring 14x6,5x1 - brass tempered (22kg-50lbs)	Garniture de cuivre 14x6,5x1 (22kg-50lb)	Dichtungsring 14x6,5x1Kupfer (22kg-50lb)
23	309963240610	Screw M6x10PK (22kg-50lbs)	Vis M6x10PK (22kg-50lb)	Schraube M6x10PK (22kg-50lb)
25	R16105000113	Bearing house (16kg-35lbs)	Moyeu (16kg-35lb)	Nabe (16kg-35lb)
26	PRI608000067	Bearing, (16kg-35lbs)	Roulement, (16kg-35lb)	Lager, (16kg-35lb)
27	PRI608000002	Bearing, (16kg-35lbs)	Roulement, (16kg-35lb)	Lager, (16kg-35lb)
28	PRI530020013	Counter ring (16kg-35lbs)	Bague de l'axe (16kg-35lb)	Wellering (16kg-35lb)
29	PRI530020012	Axial seal (16kg-35lbs)	Joint axial (16kg-35lb)	Axialdichtung (16kg-35lb)
30	PRI242000009	Retaining ring 85 (16kg-35lbs)	Bague de blocage 85 (16kg-35lb)	Sicherungsring 85 (16kg-35lb)
33	R16107000011	Spoke complete (16kg-35lbs)	Bras entier (16kg-35lb)	Komplettes Arm (16kg-35lb)
34	309933241035	Screw M10x35 stainless steel (16kg-35lbs)	Vis inox M10x35 (16kg-35lb)	Schraube M10x35 nichtrostend (16kg-35lb)
35	309912121040	Screw M10x40 (16kg-35lbs)	Vis M10x40 (16kg-35lb)	Schraube M10x40 (16kg-35lb)
37	310934000010	Nut M10 (16kg-35lbs)	Écrou M10 (16kg-35lb)	Mutter M10 (16kg-35lb)
38	310985000010	Self locking nut M10 (16kg-35lbs)	Écrou arêteoir M10 (16kg-35lb)	Selbstsichernde Mutter M10 (16kg-35lb)
39	PRI230000003	Seal ring 22x11x1 (16kg-35lbs)	Bague d'étanchéité 22x11x1 (16kg-35lb)	Dichtungsring 22x11x1 (16kg-35lb)
40	PRI245000025	Spring lock washer M10 DIN 127 (16kg-35lbs)	Rondelle élastique M10 DIN 127(16kg-35lb)	Unterlegscheibe M10 DIN 127 (16kg-35lb)
41	311125000010	Washer 20x10,5x2 (16kg-35lbs)	Rondelle 20x10,5x2 (16kg-35lb)	Unterlegscheibe 20x10,5x2 (16kg-35lb)

Зип Общепит

vsezip.ru

+7(812)987-08-81

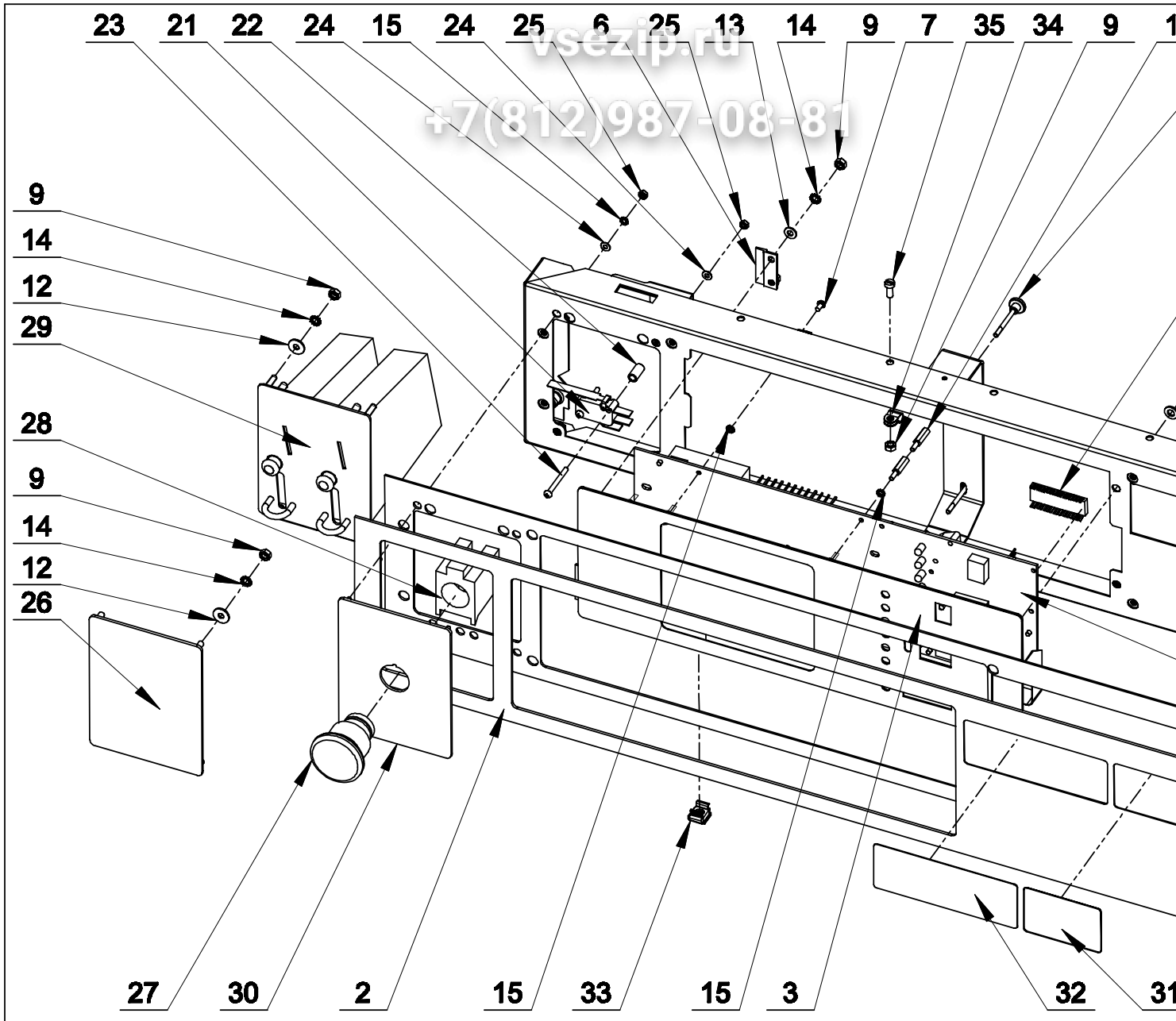

Зип Общепит

Nº	Code	Description	Designation	Bezeichnung
1	504893	Control panel MCB		
2	500152	Facia panel grey		
3	PRI348000123	Keyboard grey MCB EC		
3	100521	Keyboard grey MCB FC		
3	101490	Keyboard MCB EC grey vandal proof		
4	516694	Timer MCB EC		
4	516696	Timer MCB FC		
4	516884	Timer MCB EC, (for vandalism free keyboard)		
5	526001	Memory		
6	PRI185000228	Z-profil keyboard		
7	309798500306	Bolt M3x6		
8	310934000005	Nut M5		
9	310934000004	Nut M4		
10	311127000005	Washer M5		
11	311125000005	Washer M5		
12	311902100004	Washer M4		
13	311125000004	Washer M4		
14	311679800004	Lock washer external teeth M4		
15	311679800003	Washer M3		
16	514834	Control panel label, (for vandalism free keyboard)		
17	PRI543000004	Plastic cover		
18	510846	Adhesive tape reversible		
19	101040	Spacer M3x15		
20	101041	Knurled thumb screw with collar M3x30		
21	PRI610011077	Microswitch		
22	503168	Round plastic spacer		
23	503170	Bolt M3x30		
24	311125000003	Washer M3		
25	310934000003	Nut M3		
26	101266	Logo label (grey)		
27	102259	Emergency stop button		
28	102260	Contact block		
29		Coinmeter, (according to the order)		
30	521701	Label OPL (grey)		
31	519394	Label 18 kg grey		
31	PRI549014001	Label 22 kg grey		
32	PRI549017001	Name plate grey		
33	PRI229000004	Square nut in cage M6, (applicable for coinmeter)		
34	502214	Tube clip		
35	309084000410	Bolt M4x10		
		Wash programmms label, (according to language, not shown)		

Зип Общепит

vsezip.ru

+7(812)987-08-81

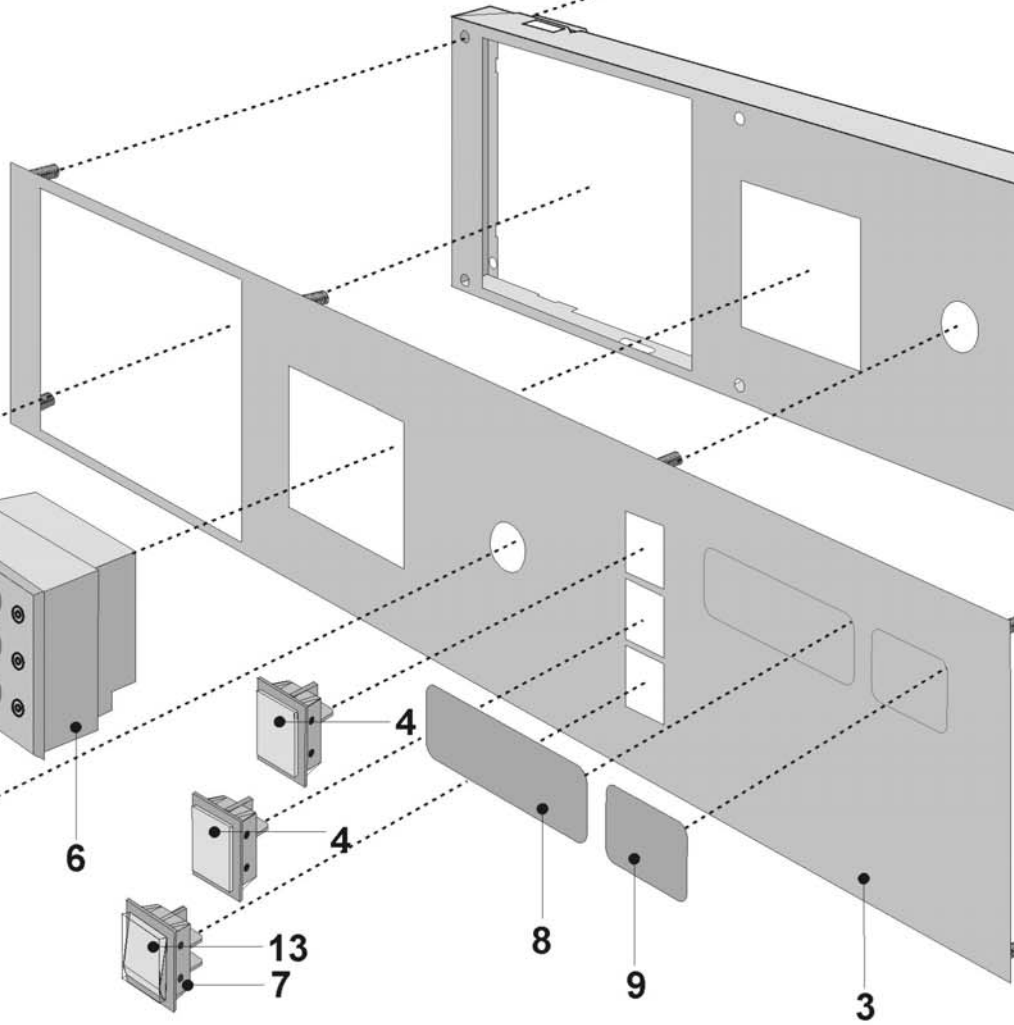
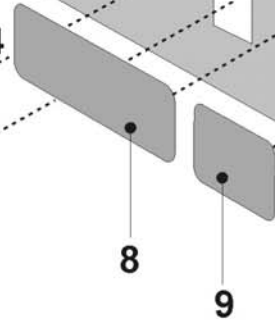
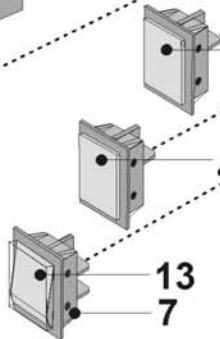
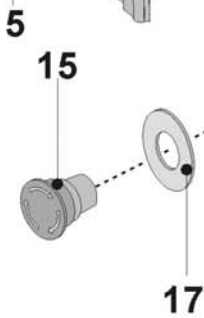
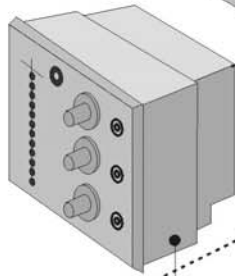
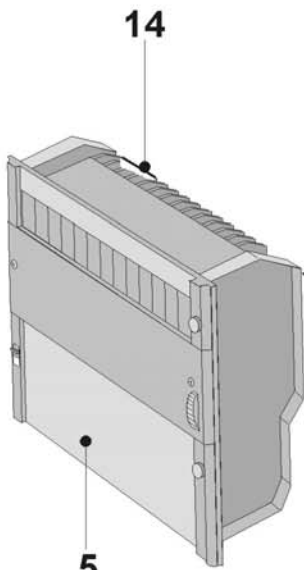
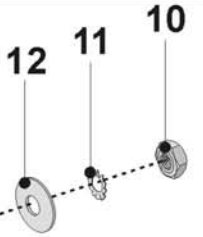
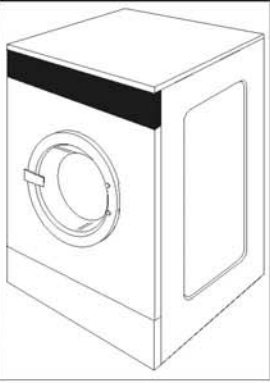

Зип Ощепит

N°	Code	Description	Designation	Bezeichnung
1	PRI340015019	Card control temperature sensor	Sonde thermostat	Thermostatgeber
2	R16116900023	Card control panel	Pupitre de commande program. à cartes	Steuertafel mit Kartenprogrammator
3	PRI549017041	Card control facial panel	Plaque de fixation pupitre	Tafelschild mit Kartenprogrammator
4	PRI348012097	Green lamp	Lampe énonc verte	Meldeleuchte grün
5	PRI343009028	Card controller	Programmeur à cartes	Kartenprogrammator
6	506500	Thermostat	Thermostat	Thermostat
7	345020123709	Push button with green cover	Bouton-poussoir avec couvercle verte	Taster mit deckung grün
8	PRI549017001	Name plate	Plaque du firme	Firmenschild
9	PRI549013001	Index plate capacity 16kg grey	Etiquette gris 16 kg	Schild grau 16 kg
	PRI549109001	Index plate capacity 16kg black	Etiquette noir 16 kg	Schild schwarz 16 kg
	PRI549028001	Index plate capacity 35lbs grey	Etiquette gris 35 lbs	Schild grau 35 lbs
	PRI549014001	Index plate capacity 22kg grey	Etiquette gris 22 kg	Schild grau 22 kg
	100393	Index plate capacity 22kg black	Etiquette noir 22 kg	Schild schwarz 22 kg
	PRI549027001	Index plate capacity 50lbs grey	Etiquette gris 50 lbs	Schild grau 50 lbs
10	310934000004	Nut M4 DIN 934	Écrou M4 DIN 934	Mutter M4 DIN 934
11	311679800004	Lock washer external teeth M4 DIN 6798	Rondelle à crans M4 DIN 6798	Fächerunterlegscheibe M4 DIN 6798
12	311902100004	Washer 12x4,33x1	Rondelle 12x4,33x1	Unterlegscheibe 12x4,33x1
13	PRI543000003	Push button cover	Protecteur	Tasterabdeckung
14	223245000825	Microswitch pin	Fixe	Trapez
15	102259	Emergency knob	Bouton-arrêt d'urgence	Zentralstop-Taster
16	102260	Emergency block	Bloc arrêt d'urgence	Zentralstop-Block
17	PRI551005248	Sticker "emergency stop"	Plaquette "botón de emergencia"	Zentralstop-Schild

Зип Общепит

vsezip.ru

+7(812)987-08-81

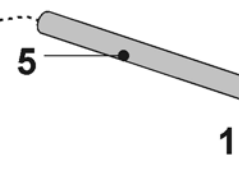
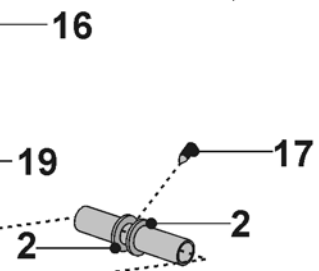
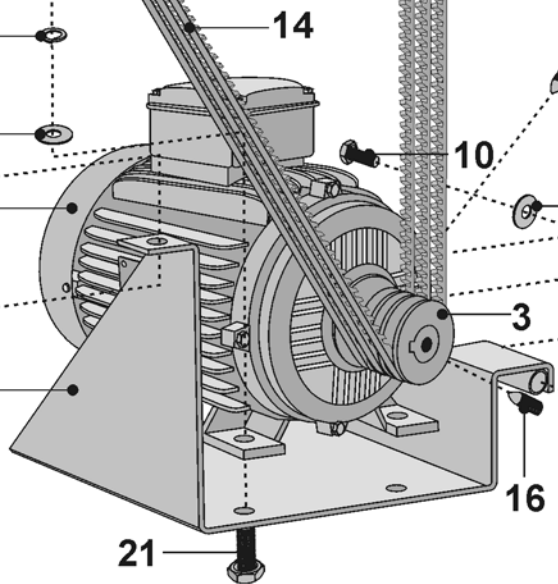
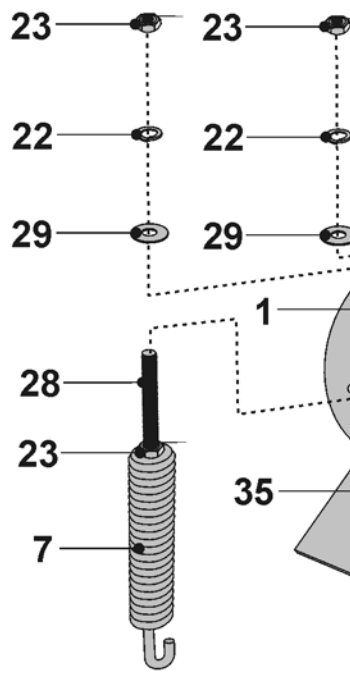
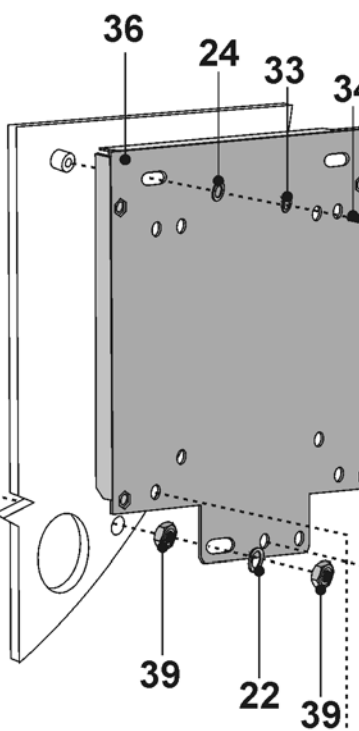
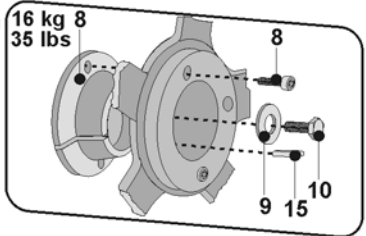
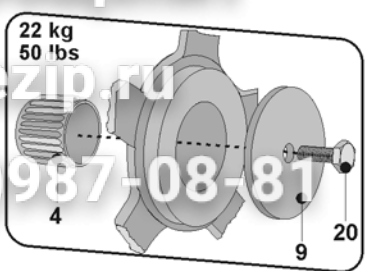
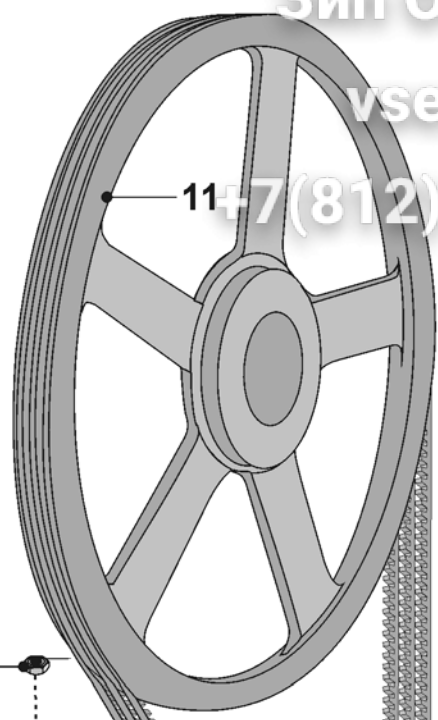
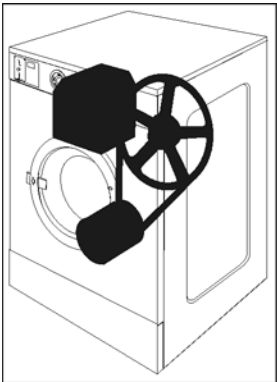

Зип Общепит

N°	Code	Description	Designation	Bezeichnung
1	PRI320000013	Motor	Moteur	Motor
2	R16100010814	Retaining ring	Bague de blocage	Sicherheitsring
3	PRI606000089	Pulley	Poulie	Riemenscheibe
4	PRI609002053	Tolerance ring, 22kg	Douille de montage, 22kg	Distanzbuchse, 22kg
5	R22100010714	Motor shaft 22kg	Axe de moteur 22kg	Motorbolzen 22kg
5	R16100010714	Motor shaft 16kg	Axe de moteur 16kg	Motorbolzen 16kg
5	R16100012014	Motor pin sleeve	Douille de moteur	Motorhülse
7	315160205013	Motor spring	Ressort	Motorfeder
8	PRI606013050	Socket key hole with screw, 16kg	Douille de la poulie à courroie + vis 16 kg	Riemenscheibenhülse + Schraube (16kg-35l)
9	PRI609010153	Washer 90x10 22kg	Rondelle 90x10 22kg	Unterlegscheibe 90x10 22kg
9	PRI231000040	Washer 30x13x6 16kg	Rondelle 30x13x6 16kg	Unterlegscheibe 30x13x6 16kg
10	309933001235	Bolt M12x35	Vis M12x35	Schraube M12x35
11	PRI606000086	V-pulley 450 16kg	Poulie 450 16kg	Riemenscheibe 450 16kg
11	PRI606000087	V-pulley 450 22kg	Poulie 450 22kg	Riemenscheibe 450 22kg
13	101822	Frequency inverter 1-ph 230V	Changeur de fréquence 1-ph 230V	Frequenzwandler 1-ph 230V
13	101824	Frequency inverter 3-ph 400V	Changeur de fréquence 3-ph 400V	Frequenzwandler 3-ph 400V
13	100946	Brake resistor, applicable for 3-ph 440/480V	Résistance du frein, valable pour 3-ph 440/480V	Bremswiderstand, gültig für 3-ph 440/480V
13	102424	Frequency inverter fan	Changeur de fréquence ventilateur	Frequenzwandler Ventilator
13	508442	Communication cable	Câble de communication	Kommunikationskabel
14	PRI607000072	V-belt, 16kg	Courroie, 16 kg	Riemen, 16 kg
15	PRI252000003	Tongue 10x8x60	Téton 10x8x60	Zapfen 10x8x60
16	309916450810	Screw M8x10	Vis M8x10	Selbstschneidschraube M8x10
17	309916000606	Screw M6x6	Vis M6x6	Selbstschneidschraube M6x6
19	311125000013	Washer 24x13x2,5	Rondelle 24x13x2,5	Unterlegscheibe 24x13x2,5
20	309933001450	Bolt M14x50 (22kg-50lbs)	Vis M14x50 (22kg-50lbs)	Schraube M14x50 (22kg-50lbs)
21	309933000825	Bolt M8x25	Vis M8x25	Schraube M8x25
22	311127000008	Washer 8	Rondelle 8	Unterlegscheibe 8
23	310934000008	Nut M8	Écrou M8	Mutter M8
24	311125240006	Washer 6,4	Rondelle 6,4	Unterlegscheibe 6,4
25	311125240004	Washer 4,3	Rondelle 4,3	Unterlegscheibe 4,3
26	311679824004	Washer M4	Rondelle M4	Unterlegscheibe M4
27	309084000410	Bolt M4x10	Vis M4x10	Schraube M4x10
28	309933001270	Bolt M8x70	Vis M8x70	Schraube M8x70
29	311125000084	Washer 8,4	Rondelle 8,4	Unterlegscheibe 8,4
33	311127240006	Washer 6	Rondelle 6	Unterlegscheibe 6
34	309933000616	Bolt M6x16	Vis M6x16	Schraube M6x16
35	514830	Motor holder	Support de moteur	Motorhalter
36	514825	Plate of inverter	Butée convertidor de frecuencias	Frequenzwandleranschlag
37	514824	Cover of inverter	Couvercle de changeur de fréquence	Frequenzwandlerabdeckung
38	514828	Front cover	Couvercle de devant	Vordeckabdeckung
39	310985000008	Nut M8	Écrou M8	Mutter M8
40	309933000850	Bolt M8x50	Vis M8x50	Schraube M8x50
41	F05109000214	Cable socket	Bague du cable	Kabelhülse

Зип Ощепит

vsezip.ru

+7(812)987-03-815

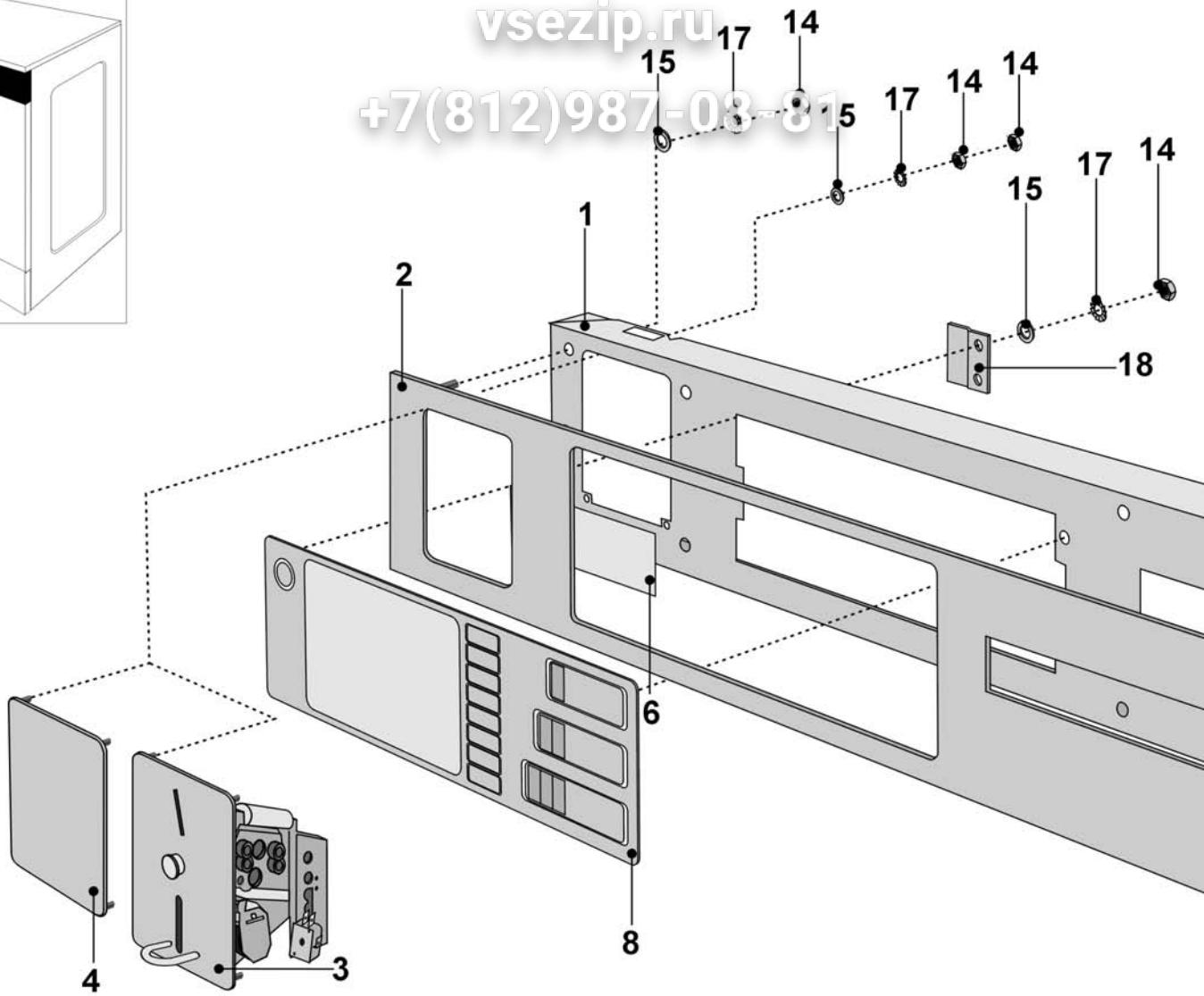
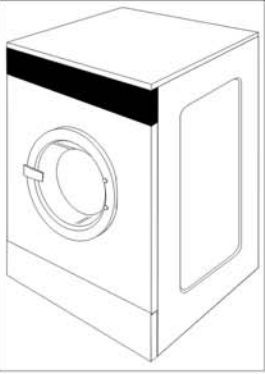

Зип Общепит

N°	Code	Description	Designation	Bezeichnung
1	519240	Control panel MCB EC with mechanical buttons	Panneau de commande MCB EC et aux boutons mécaniques	Steuerpaneel MCB EC mit mechanischen t
2	516710	Facia panel	Panneau avant	Vorderpaneel
3		Coin meter	Monnayeur	Münzgerät
4	101266	Logo label	Étiquette avec logo	Schild Logo
5	311125000005	Washer 5	Rondelle 5	Unterlegscheibe 5
6	516706	Label, applicable for 16kg / 35lbs	Ecusson, valable pour 16kg / 35lbs	Schild, gilt für 16kg / 35lbs
6	516707	Label, applicable for 22kg / 50lbs	Ecusson, valable pour 22kg / 50lbs	Schild, gilt für 22kg / 50lbs
7	PRI348011091	6-buttons switch	Interrupteur à 6 boutons	6-Tastenschalter
8	516666	Keyboard	Clavier	Tastatur
9	516694	Timer MCB EC	Programateur MCB EC	Programmator MCB EC
10	102228	Memory	Mémoire	Speicher
11	309084000308	Bolt M3x8	Vis M3x8	Schraube M3x8
12	311679824003	Washer M3	Rondelle 5	Unterlegscheibe 5
13	PRI543000005	Washer	Rondelle	Unterlegscheibe
14	310934000004	Nut M4	Écrou M4	Mutter M4
15	311125000004	Washer M4	Rondelle M4	Unterlegscheibe M4
16	310934000005	Nut M5	Écrou M5	Mutter M5
17	311679800004	Washer M4	Rondelle M4	Unterlegscheibe M4
18	PRI185000228	Z-profile	Profil Z	Z-Profil
19	311127000005	Washer 5	Rondelle 5	Unterlegscheibe 5
20	PRI543000004	Plastic cover	Couvercle plastique	Kunststoffabdeckung

Зип Общепит

vsezip.ru

+7(812)987-08-81

Зип Общепит

vsezip.ru

+7(812)987-08-81