



Зип Общепит

vsezip.ru

+7(812)987-08-81

RICAMBI

*SPARE PARTS - PIECES DETACHEES - ERSATZTEILE
REPUESTOS - PEÇAS DE SUBSTITUIÇÃO*

Зип Общепит



vsezip.ru

+7(812)987-08-81

vsezip.ru
+7(812)987-08-81

Pos.	Cod.	Q.tà	ITA	GB	F	D	E	P	NOTE
1	KG24210	1	Angolare ferro refrattario	Angle piece	Encoignure	Eckingstueck	Esquinal	Angular	635S - 435
1	KG24610	1	Angolare ferro refrattario	Angle piece	Encoignure	Eckingstueck	Esquinal	Angular	635S / 355x1047x19
1	KG25010	1	Angolare ferro refrattario	Angle piece	Encoignure	Eckingstueck	Esquinal	Angular	635XL
2	AL20400	2	Pietra	Stone	Pierre	Stein	Piedra	Pedra	435 / 697x355x19
2	AL30300	2	Pietra	Stone	Pierre	Stein	Piedra	Pedra	635L / 557,5x697x19
2	AL32000	2	Pietra	Stone	Pierre	Stein	Piedra	Pedra	935 / 557,4x1047x19
2	AL32100	3	Pietra	Stone	Pierre	Stein	Piedra	Pedra	635XL / 415x697x19
2	AL32400	2	Pietra	Stone	Pierre	Stein	Piedra	Pedra	635S / 355x1047x19
3	WP24311	2	Fianco	Panel	Tableau	Tafel	Panel	Lado	des.-sin. 435 - 635L - 635XL
3	WP44610	2	Fianco	Panel	Tableau	Tafel	Panel	Lado	des.-sin. 635S - 935
4	WP24711	1	Schienale	Back	Dossier	Rueckenlehne	Respaldo	Parte traseira	635L - 935
4	WP45211	1	Schienale	Back	Dossier	Rueckenlehne	Respaldo	Parte traseira	435 - 635S
4	WP45311	1	Schienale	Back	Dossier	Rueckenlehne	Respaldo	Parte traseira	635XL
5	WP3T100	1	Pannello frontale	Panel	Panneau	Schalttafel	Panel	Painél	E. / des.
5	WP3T700	1	Pannello frontale	Panel	Panneau	Schalttafel	Panel	Painél	M. / des.
6	WP3T200	1	Pannello frontale	Panel	Panneau	Schalttafel	Panel	Painél	E. - M. / sin.
7	MD14700	4	Molletta	Grip	Epingle	Klammer	Pinza	Mola	
8	EN14500	2	Chiusura magnetica	Closing	Fermeture	Verschluss	Cierre	Fecho	
9	WP3T310	1	Cappa	Hood	Hotte	Kappe	Campana	Exaustor	435 - 635S
9	WP3T510	1	Cappa	Hood	Hotte	Kappe	Campana	Exaustor	935 - 635L
9	WP3T810	1	Cappa	Hood	Hotte	Kappe	Campana	Exaustor	635XL
10	W3P4810	1	Scivolo sup.	Chute	Goulotte	Rutsche	Rampa	Rampa	635XL
10	W3P4910	1	Scivolo sup.	Chute	Goulotte	Rutsche	Rampa	Rampa	635S - 435
10	W3P5010	1	Scivolo sup.	Chute	Goulotte	Rutsche	Rampa	Rampa	935 - 635L
11	WP3T410	1	Leccarda	Crumbs gathering element	Ramasse-miettes	Krummsammler	Recogedor de migas	Recolhe-migalhas	435 - 635S
11	WP3T610	1	Leccarda	Crumbs gathering element	Ramasse-miettes	Krummsammler	Recogedor de migas	Recolhe-migalhas	935 - 635L
11	WP3T910	1	Leccarda	Crumbs gathering element	Ramasse-miettes	Krummsammler	Recogedor de migas	Recolhe-migalhas	635XL
12	WSL4000	1	Traversa cappa	Crossrail	Traverse	Traverse	Traversano	Travessa	935 - 635L
12	WSL4100	1	Traversa cappa	Crossrail	Traverse	Traverse	Traversano	Travessa	635XL

E.= Electronico, Electronic, Électronique, Elektronisch, Electrónico, Electrónico

M.= Meccanico, Mechanical, Mécanique, Mechanisch, Mecánico, Mecánico

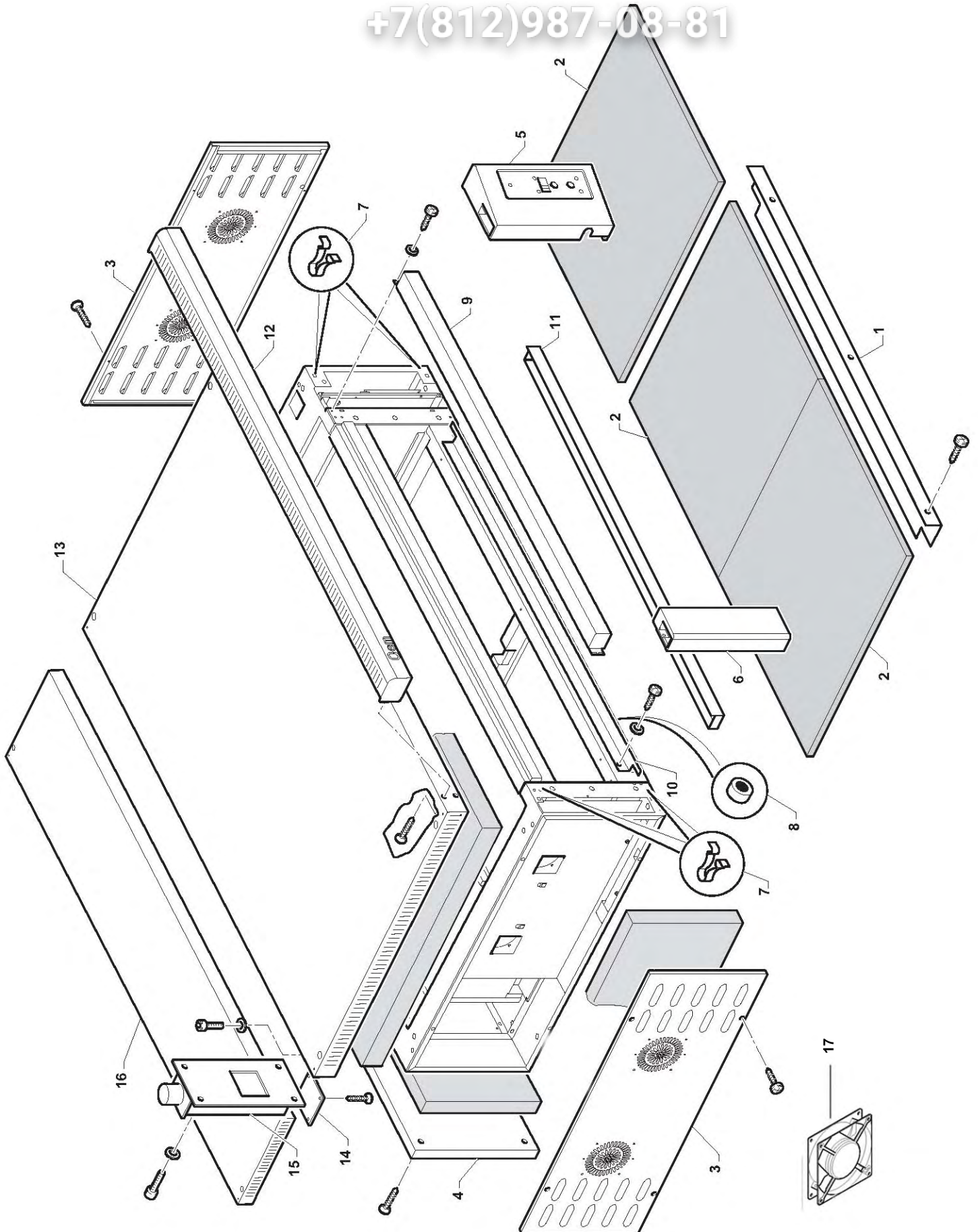

FIG.1

Pannelli
Panels - Panneaux
Verkleidungen- Paneles - Painéis

Зип Общепит



vsezip.ru

+7(812)987-08-81

Pos.	Cod.	Q.tà	ITA	GB	F	D	E	P	NOTE
12	WSS0800	1	Traversa cappa	Crossrail	Traverse	Traverse	Traversano	Traversa	435 - 635S
13	W3PC110	1	Coperchio	Cover	Couvercle	Deckel	Tapa	Tampa	635XL
13	WPC1210	1	Coperchio	Cover	Couvercle	Deckel	Tapa	Tampa	635S - 435
13	WPC2610	1	Coperchio	Cover	Couvercle	Deckel	Tapa	Tampa	635L - 935
14	WCE3710	1	Tappo	Plug	Bouchon	Stopfen	Tapon	Tampa	
15	W3E1500	1	Camino completo	Chimney complete	Cheminée complète	Schornstein komplett	Chimenea completa	Chaminé completa	
16	WPC0610	1	Coperchio	Cover	Couvercle	Deckel	Tapa	Tampa	635/S
16	WPC2810	1	Coperchio	Cover	Couvercle	Deckel	Tapa	Tampa	935
16	ES22700	1	Ventola	Blower	Sufflerie	Geblaese	Pantalla	Ventoinha	

E.= Electronico, Electronic, Electronique, Elektronisch, Electrónico, Electrónico

M.= Meccanico, Mechanical, Mécanique, Mechanisch, Mecánico, Mecânico

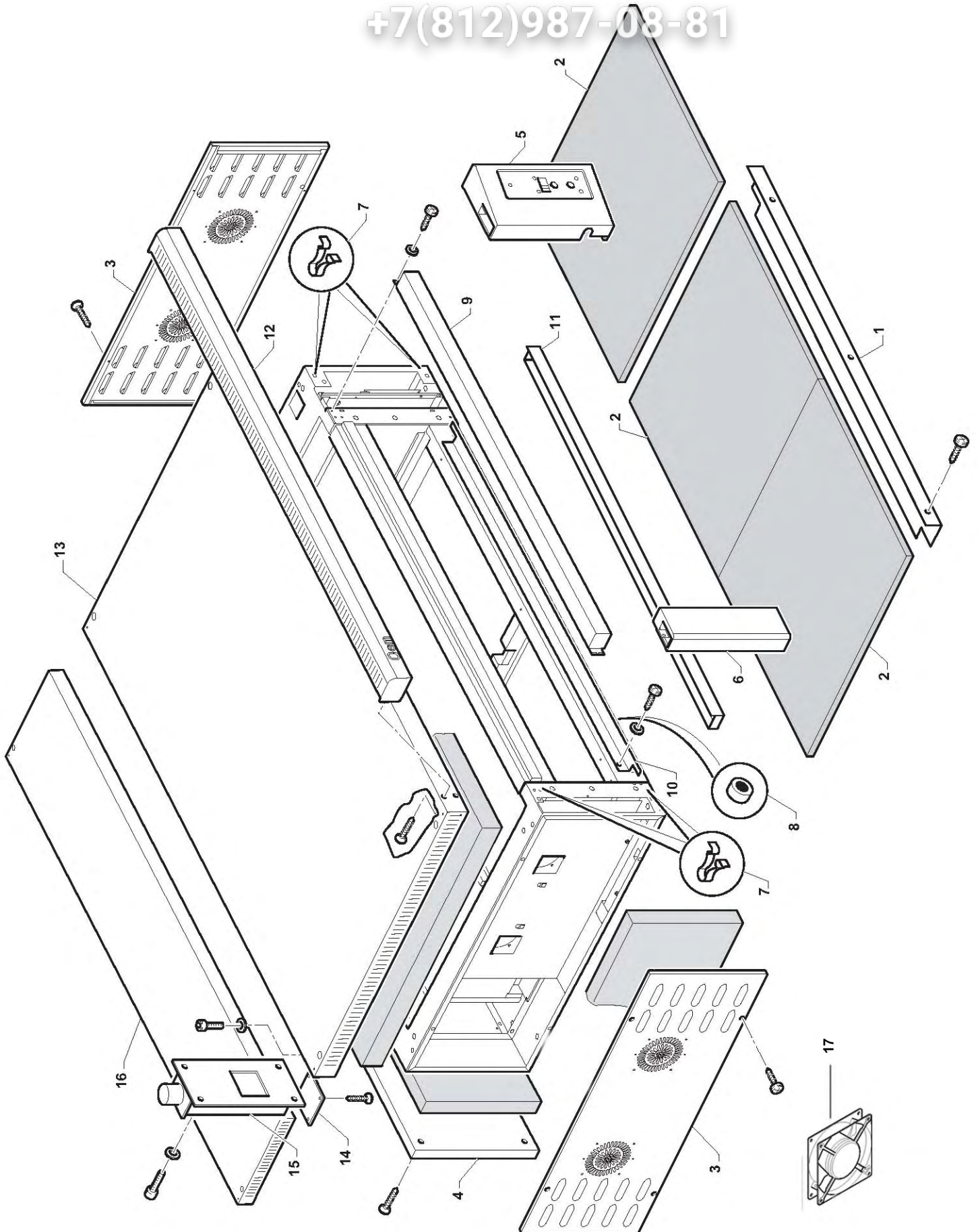

vsezip.ru

+7(812)987-08-81

Pos.	Cod.	Q.tà	ITA	GB	F	D	E	P	NOTE
1	HAT9910	1	Protezione bulbo	Shield	Protection	Abdeckung	Defensa	Proteção	
2	WKL0610	2	Angolare	Angle piece	Encoignure	Eckingstueck	Esquinal	Angular	635XL
2	WKL0710	2	Angolare	Angle piece	Encoignure	Eckingstueck	Esquinal	Angular	935 - 635L
2	WKS0510	2	Angolare	Angle piece	Encoignure	Eckingstueck	Esquinal	Angular	435 - 635S
3	MD03600	4	Copiglia	Cotter pin	Coupille	Splint	Pasador abierto	Dente de aço	
4	W3P4210	2	Sostegno lampada	Support	Support	lager	Supporte	Supporte	
5	EL06900	2	Portatampada+	Porte-lampe+	Porte-lampe+	Lampenfassung+	Supporte lampara+	Porta-lâmpada+	65 cm
			Cavi	Cables	Cables	Leitungen	Cables	cabos	
6	EE28700	12	Resistenza	Resistor	Resistance	Widerstand	Resistencia	Resistência	935/W.1100 V.230
6	EE29200	6	Resistenza	Resistor	Resistance	Widerstand	Resistencia	Resistência	635S / W.1650 V.230
6	EE29300	6	Resistenza	Resistor	Resistance	Widerstand	Resistencia	Resistência	435 / W.1100 V.230
6	EE29400	12	Resistenza	Resistor	Resistance	Widerstand	Resistencia	Resistência	635L / W.875 V.230
6	EE29500	10	Resistenza	Resistor	Resistance	Widerstand	Resistencia	Resistência	635XL / W.1000 V.230
6	EE29700	2	Resistenza	Resistor	Resistance	Widerstand	Resistencia	Resistência	635XL / W.1300 V.230
7	QAT2200	2	Parabola luce	Light reflector	Reflecteur	Lamp Parabel	Parabola lampara	Parábola	
8	EL06600	2	Lampadina	Lamp	Lampe	Lampe	Lampara	Lampadinha	
9	AL26600	2	Guarnizione	Gasket	Joint	Dichtung	Junta	Guarnição	
10	AL20100	2	Vetro	Glass	Verre	Glas	Vidrio	Vidro	

M.= Meccanico, Mechanical, Mécanique, Mechanisch, Mecánico, Mecânico

E.= Electronico, Electronic, Electronique, Elektronisch, Electrónico, Electrónico

vsezip.ru

+7 (812) 987-08-81

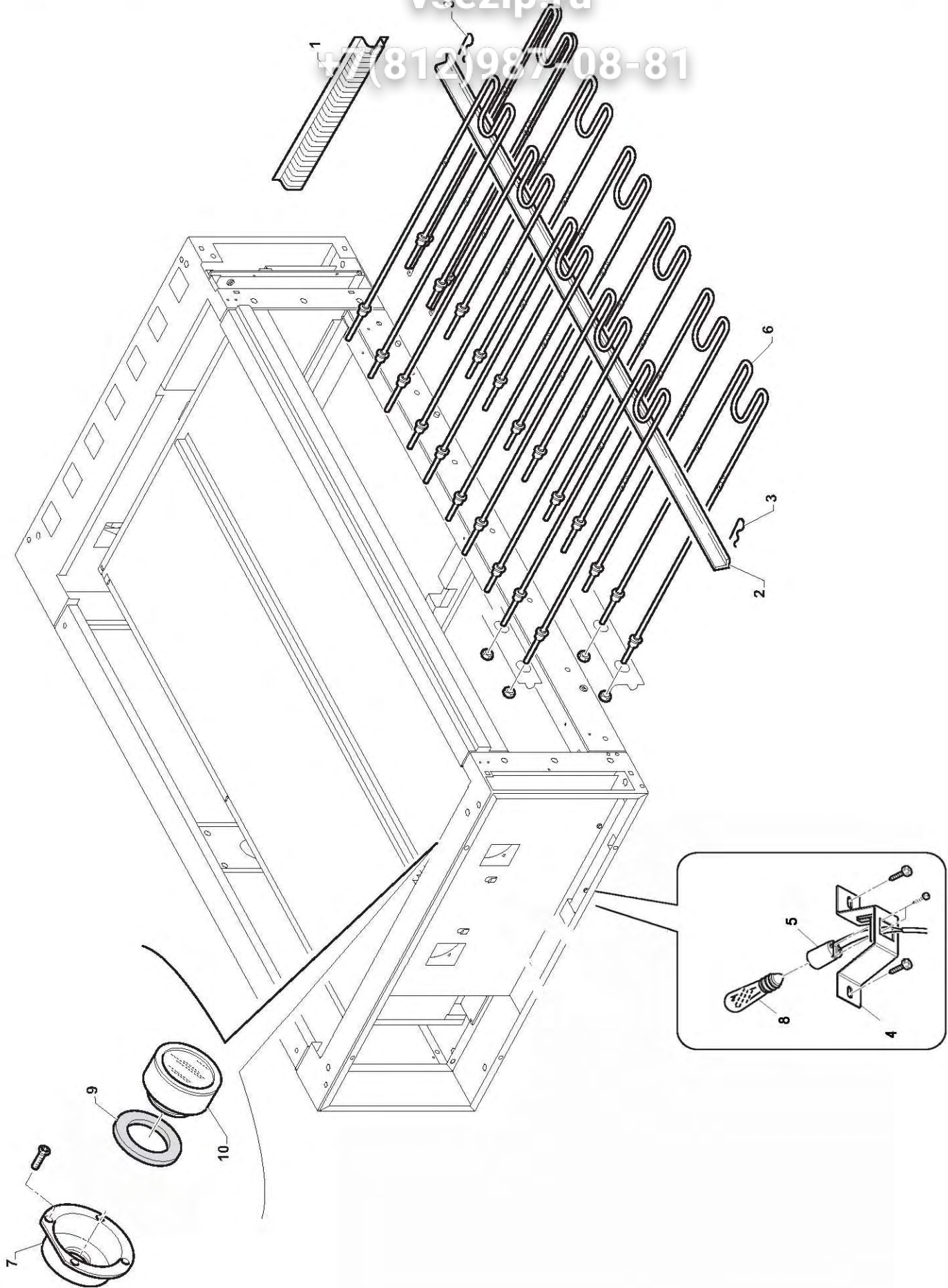

vsezip.ru
+7(812)987-08-81

Pos.	Cod.	Q.tà	ITA	GB	F	D	E	P	NOTE
1	W3M1521	1	Maniglione	Handle	Poignée	Handgriff	Tirador de la puerta	Puxador	635S - 435
1	W3M1621	1	Maniglione	Handle	Poignée	Handgriff	Tirador de la puerta	Puxador	635L - 935
1	W3M1720	1	Maniglione	Handle	Poignée	Handgriff	Tirador de la puerta	Puxador	635XL
2	W3P0010	1	Porta completa	Door complete	Porte complète	Tür komplett	Puerta completa	Porta completa	435 - 635S
2	W3P1510	1	Porta completa	Door complete	Porte complète	Tür komplett	Puerta completa	Porta completa	635L - 935
2	W3P2010	1	Porta completa	Door complete	Porte complète	Tür komplett	Puerta completa	Porta completa	635XL
3	W3DL010	1	Telaio vetro	Glass frame	Châssis verre	Glasrahmen	Armazón del vidrio	Armação vidro	935 - 635L - 635XL
3	W3DS010	1	Telaio vetro	Glass frame	Châssis verre	Glasrahmen	Armazón del vidrio	Armação vidro	635S - 435
4	W3LD310	1	Telaio superiore	Mast	Chassis	Mast	Bastidor	Armação	935 - 635L - 635XL
4	W3SD110	1	Telaio superiore	Mast	Chassis	Mast	Bastidor	Armação	635S - 435
5	W3DL610	1	Chiusura	Closing	Fermeture	Verschluss	Cierre	Fecho	935 - 635L - 635XL
5	W3DS610	1	Chiusura	Closing	Fermeture	Verschluss	Cierre	Fecho	635S - 435
6	AL31200	1	Vetro temperato	Toughened glass	Verre trempé	Vorgespanntes Glas	Vidrio templado	Vidro temperado	935 - 635L - 635XL / 836x110x4
6	AL31300	1	Vetro temperato	Toughened glass	Verre trempé	Vorgespanntes Glas	Vidrio templado	Vidro temperado	435 - 635S / 636x110x4
7	AL31000	1	Vetro ceramico	Ceramic glass	Verre céramique	Keramisches Glas	Vidrio ceramizado	Vidro cerâmica	935 - 635L - 635XL / 836x110x4
7	AL31100	1	Vetro ceramico	Ceramic glass	Verre céramique	Keramisches Glas	Vidrio ceramizado	Vidro cerâmica	435 - 635S / 636x110x4
8	W3DL100	1	Copertura pst	Cover	Couverture	Deck el	Cobertura	Cobertura	935 - 635L
8	W3DS100	1	Copertura pst	Cover	Couverture	Deck el	Cobertura	Cobertura	635S - 435
8	W3LD200	1	Copertura pst	Cover	Couverture	Deck el	Cobertura	Cobertura	635/XL
9	AL32610	1	Guarnizione	Gasket	Joint	Dichtung	Junta	Guarnição	435 - 635
9	AL32710	1	Guarnizione	Gasket	Joint	Dichtung	Junta	Guarnição	935 - 635L - 635XL
10	W3KT320	2	Sostegno porta	Support	Support	Lager	Soporte	Soporte	
11	W3KT500	2	Boccola	Bushing	Douille	Buchse	Casquillo	Presilha	
12	W3P6010	1	Bilancere SX	Culbuteur	Kipphebel	Rocker	Bilancin	Balancim	
12 A	W3P6110	1	BilancereDX	Culbuteur	Kipphebel	Rocker	Bilancin	Balancim	
13	W3M2110	1	Staffa molla	Bracket	Etrier	Halter	Soporte	Estribo	
14	MD14800	1	Molla	Spring	Ressort	Feder	Resorte	Mola	635L - 635XL - 935 - 435 - 635 S
15	MD14200	2	Grano p/piana	Dowel	Ergot	Passtift	Piton	Parafuso sem fim	6x30
16	MD15400	2	Grano p/piana	Dowel	Ergot	Passtift	Piton	Parafuso sem fim	6x8
17	MB41400	6	Vite toei	Screw	Vis	Schraube	Tornillo	Parafuso	6x60 Inox
18	MB21900	2	Vite toei	Screw	Vis	Schraube	Tornillo	Parafuso	6x12 Inox
19	MC13100	2	Rondella contact	Washer	Rondelle	Scheibe	Arandela	Arruela	
20	W3P2310	1	Porta assemblata	Door complete	Porte complète	Tür komplett	Puerta completa	Porta completa	435 - 635S
20	W3P2410	1	Porta assemblata	Door complete	Porte complète	Tür komplett	Puerta completa	Porta completa	935 - 635L
20	W3P2510	1	Porta assemblata	Door complete	Porte complète	Tür komplett	Puerta completa	Porta completa	635XL

E.= Electronico, Electronic, Électronique, Elektronisch, Electrónico, Electrónico

M.= Meccanico, Mechanical, Mécanique, Mechanisch, Mecánico, Mecánico

+7(812)987-08-81

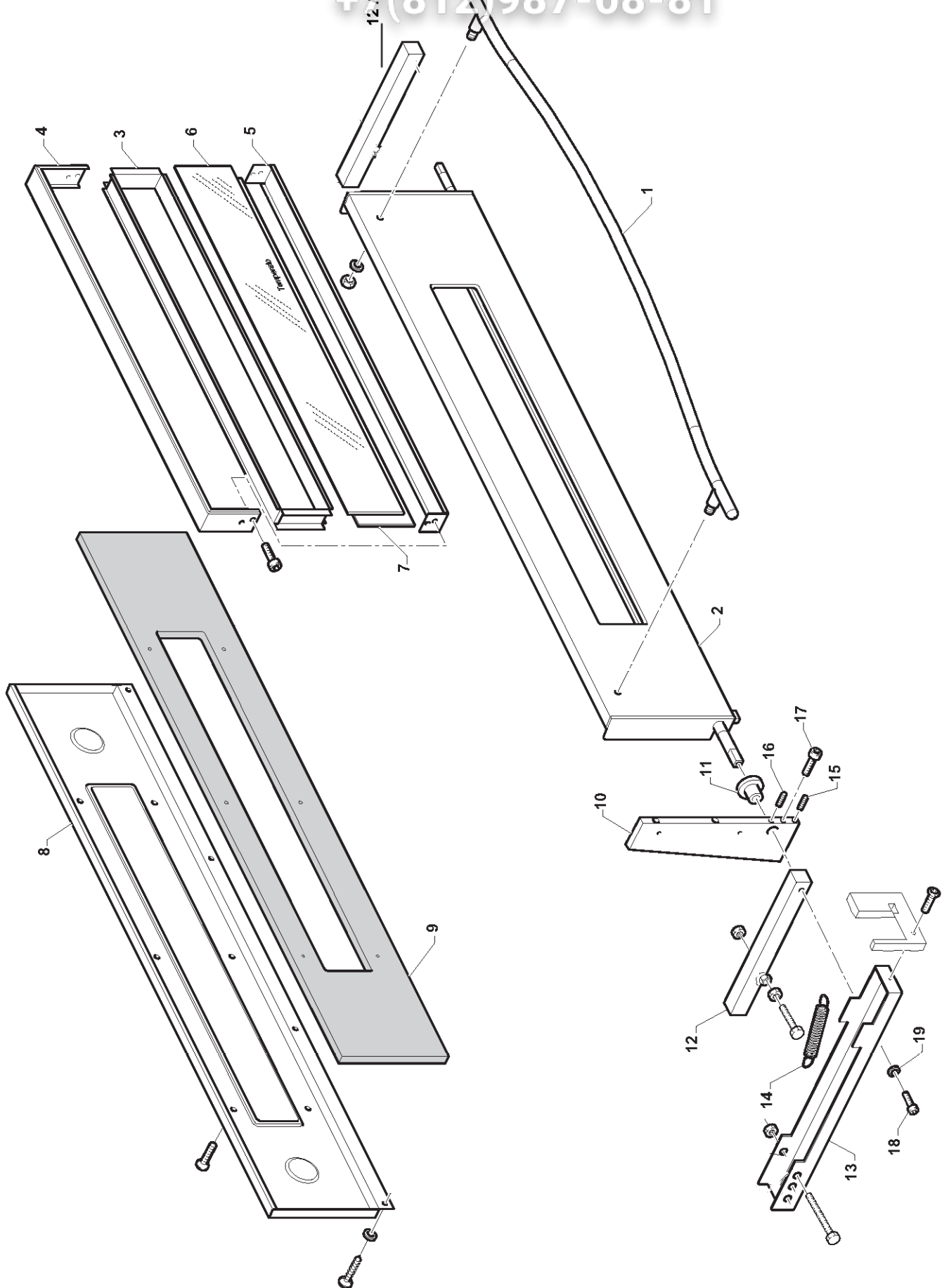

vsezip.ru

+7(812)987-08-81

Pos.	Cod.	Q.tà	ITA	GB	F	D	E	P	NOTE
1	W3I1010	1	Camino interno	Inner chimney	Cheminée interne	Imenschornstein	Chimenea interna	Chaminé interna	
2	W3E1710	1	Guida tampone	Guide	Gilssier	Fuehrung	Guia	Guia	
3	W3E2110	1	Tamponamento camino	Closure	Bouchage	Ausfachen	Tabique	Tapamento	
4	W3E1100	1	Snodo	Joint	Joint	Gelenk	Articulacion	Junta	
5	W3P1000	1	Staffa guida camino	Bracket	Etrier	Halter	Soporte	Estribo	
6	AC2I400	2	Sfera	Ball	Bille	Kugel	Bola	Esfera	
7	W3K1310	1	Protezione	Shield	Protection	Abdeckung	Defensa	Proteção	435 - 635S
7	W3K1410	1	Protezione	Shield	Protection	Abdeckung	Defensa	Proteção	635XL
7	W3K1510	1	Protezione	Shield	Protection	Abdeckung	Defensa	Proteção	635L - 935
8	W3K0100	1	Asta	Rod	Tige	Stange	Varilla	Haste	635L - 935 / E. + M.
8	W3K0200	1	Asta	Rod	Tige	Stange	Varilla	Haste	435 - 635S / E. + M.
8	W3K0300	1	Asta	Rod	Tige	Stange	Varilla	Haste	635XL / E. + M.
9	W3P0910	1	Sostegno	Support	Support	lager	Soporte	Suporte	
10	AC13600	1	Manopola	Knob	Poignee	Handgriff	Perilla	Botão	M.
11	W3K0700	1	Asta camino	Rod	Tige	Stange	Varilla	Haste	435 - 635L - 635XL / M.
11	W3K1200	1	Asta camino	Rod	Tige	Stange	Varilla	Haste	935 - 635S / M.
12	W3P5110	1	Fermo	Retainer	Areêêt	Feststellung	Retén	Dispositivo de bloqueio	M.
13	EG03300	1	Micro	Microswitch	Micro	Mikroschalter	Micro	Micro	E.
14	KD10300	1	Motorino	Motor	Petit moteur	Motor	Motor	Motor	E.
15	MD03600	1	Copiglia	Cotter pin	Couppille	Splint	Pasador abierto	Dente de aço	

E.= Electronico, Electronic, Électronique, Elektronisch, Electrónico, Electrónico

M.= Meccanico, Mechanical, Mécanique, Mechanisch, Mecánico, Mecánico

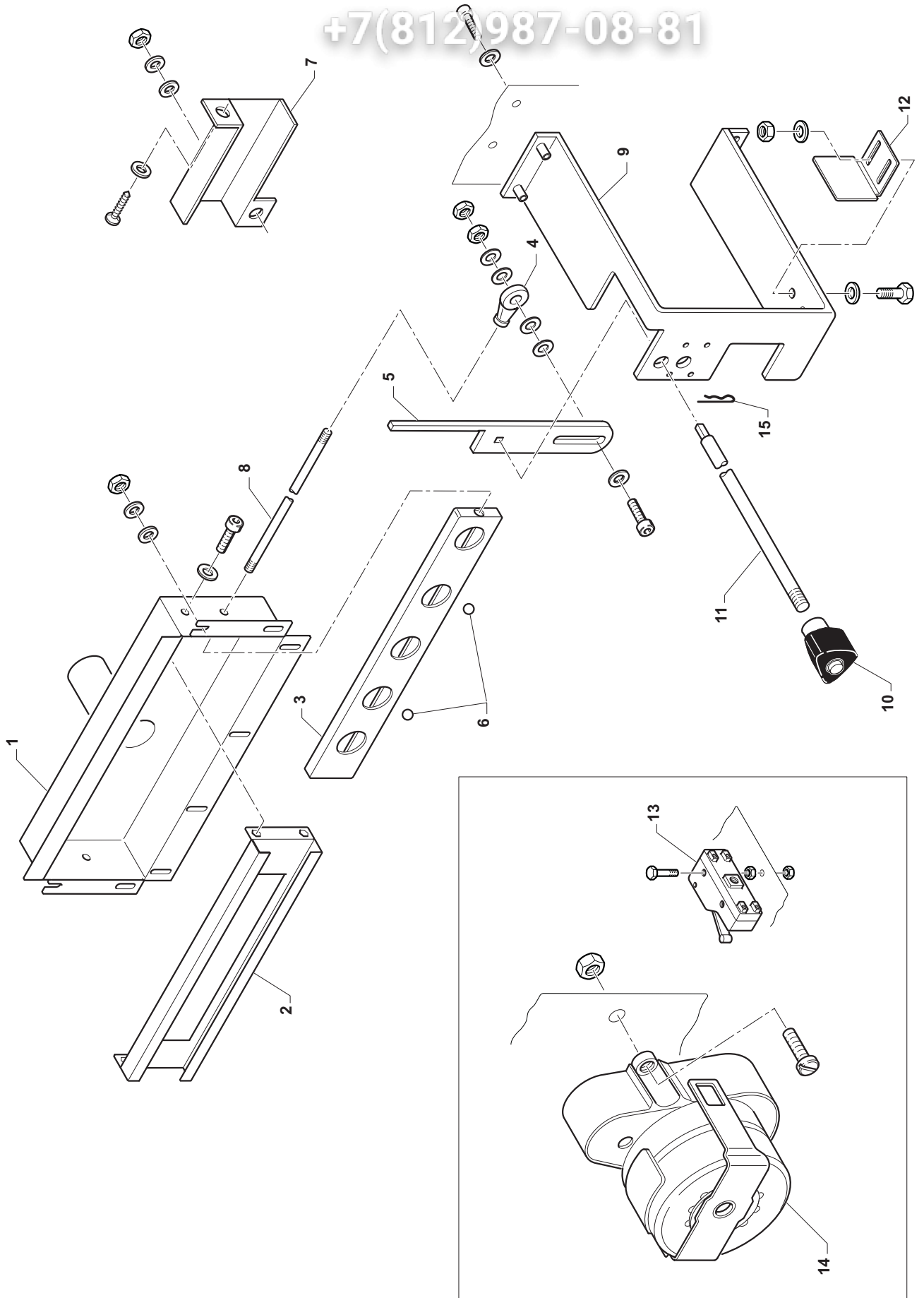

vsezip.ru

+7(812)987-08-81

Pos.	Cod.	Q. tà	ITA	GB	F	D	E	P	NOTE
1	W3P4500	1	Dissipatore	Heatsink	Dissipateur	Wärmeableiter	Disipador de calor	Dissipador	
2	ED06400	1	Termostato	Thermostat	Thermostat	Thermostat	Termostato	Termostato	
3	HE18500	1	Scheda potenza	Circuit	Circuit	Strecke	Circuito	Ficha potência	
4	HE18600	2	Scheda aggiuntiva	Additional card	Fiche additionnelle	Zusätzliche Karte	Tarjeta adicional	Ficha adicional	
5	ES22700	1	Ventola	Blower	Sufflerie	Geblaese	Pantalla	Ventoinha	→
7	W3P4710	1	Supporto	Support	Support	Halterung	Soporte	Supporte	
8	EN08300	1	Teleruttore	Remote switch	Contacteur	Schuetz	Teleruptor	Interruptor com controle remoto	
9	EP00900	1	Morsetto a vite	Terminal	Borne	Klemme	Borne	Grampo	10 mm2
10	HE18900	1	Scheda	Card	Fiche	Schalttafel	Ficha	Ficha	
11	EP07100	1	Morsetto terra	Terminal	Borne	Klemme	Borne	Grampo	10 mm2
12	AD00600	1	Pressacavo+viti	Cable pressing element+screws	Pressecâble+ vis	Kabelpresselenent +Schrauben	Sujetacable+ tornillos	Prensa-cabo+ parafusos	
13	ED02300	1	Termostato di sicurezza	Thermostat	Thermostat	Thermostat	Termostato	Termostato	
14	ED08320	1	Termoresistenza	Thermoresistance	Thermo-résistance	Thermowiderstand	Termo-resistencia	Termo-resistência	
15	HS12120	1	Impianto elettrico completo	Wiring system complete	Système électrique complet	Elektrische Anlage komplett	Instalación eléctrica completa	Instalação eléctrica completa	
16	AC15200	2	Manopola	Knob	Poignee	Handgriff	Perilla	Botão	
17	AM45200	1	Targa	Nameplate	Plaque	Namensschild	Chapa	Placa	

E.= Electronico, Electronic, Électronique, Elektronisch, Electrónico, Electrónico

M.= Meccanico, Mechanical, Mécanique, Mechanisch, Mecánico, Mecânico

vsezip.ru

+7(812)987-08-81

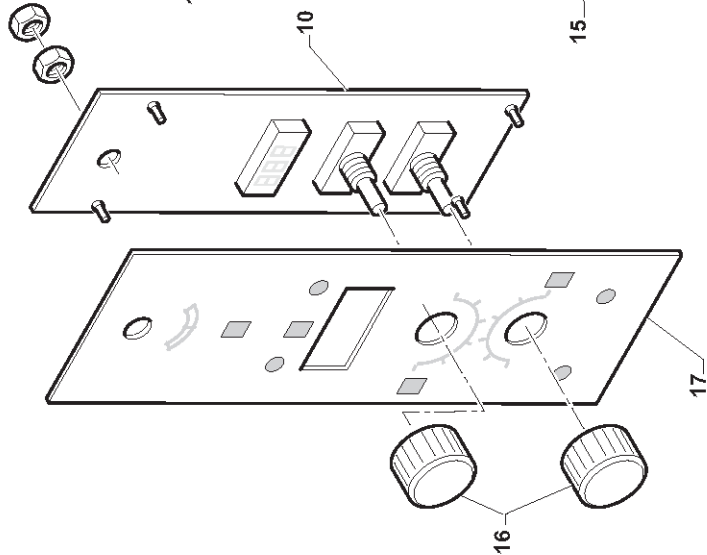
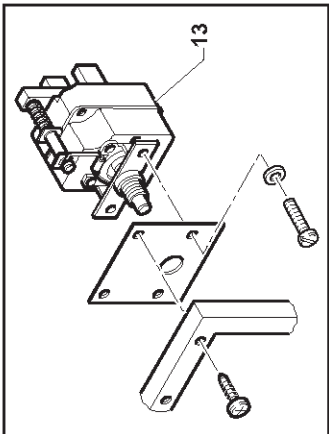
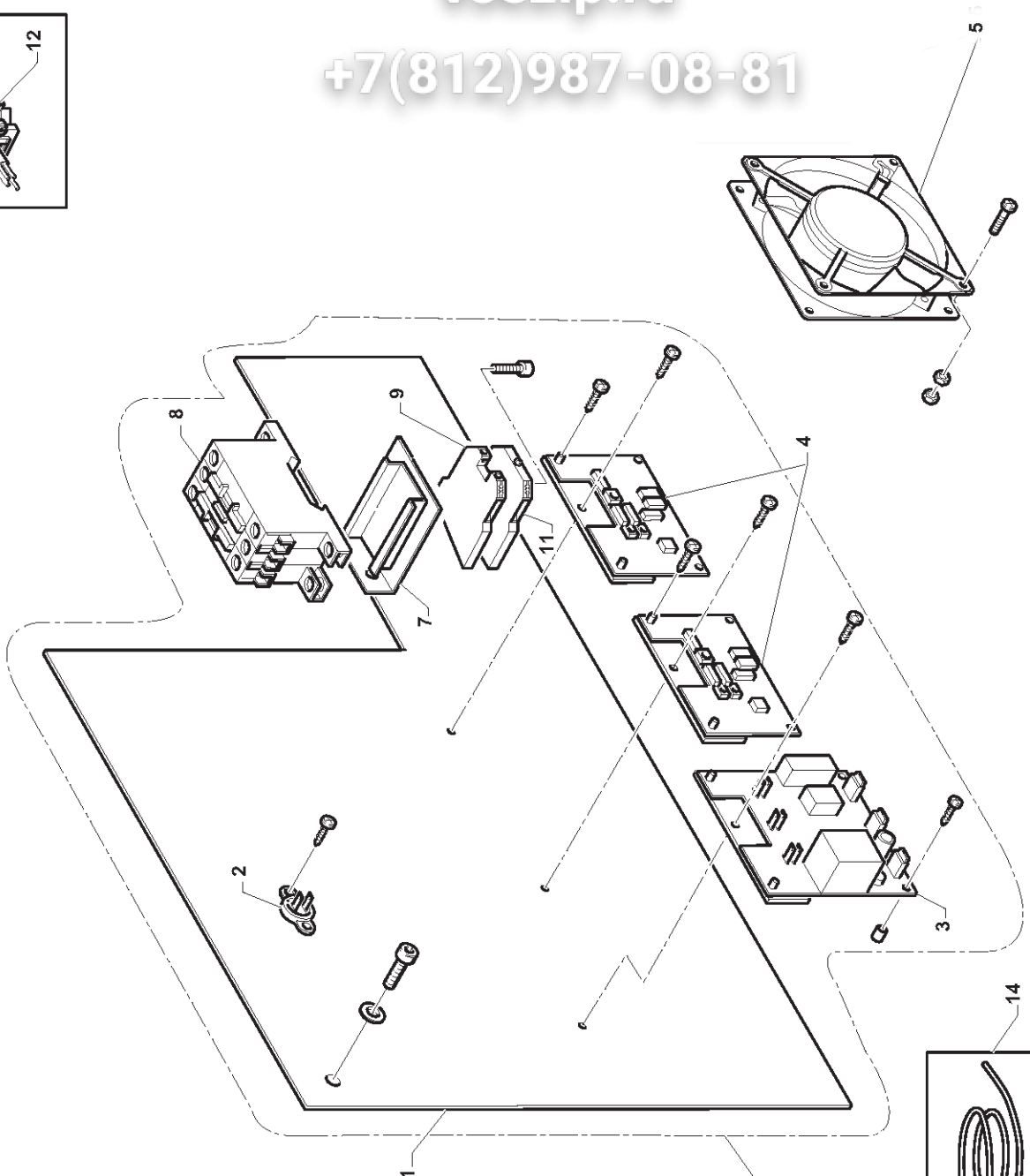
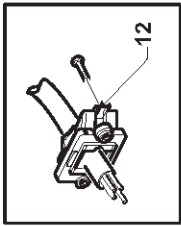

vsezip.ru
 +7(812)987-08-81

Pos.	Cod.	Q.tà	ITA	GB	F	D	E	P	NOTE
1	HE19200	1	Scheda potenza	Circuit	Circuit	Strecke	Circuito		
2	HE18700	1	Scheda velocità	Speed card	Fiche vitesse	Geschw.-Karte	Tarjeta de velocidad	Ficha velocidade	
3	EN01700	1	Zoccolo	Base	Support	Socket	Casquillo	Base	
4	EN14400	1	Relè	Relay	Relè	Relais	Relè	Relé	24V
5	ED06500	1	Termocoppia	Thermocouple	Thermocouple	Thermoelement	Termopar	Termo-par	
6	EM02620	1	Condensatore	Condenser	Condensateur	Kondensator	Viertauguas	Condensador	
7	AD19700	1	Pressacavo	Cable pressing element	Pressecâble	Kabelpresselement	Sujetacable	Prensa-cabo	
8	AD20300	1	Dado	Nut	Ecrou	Mutter	Tuerca	Porca	
9	AM45100	1	Targa	Nameplate	Plaque	Namensschild	Chapa	Placa	
10	EP07100	1	Morsetto terra	Terminal	Borne	Klemme	Borne	Grampo	10mm2
12	W3P4710	1	Supporto	Support	Support	Halterung	Soporte	Suporte	
13	EN08300	1	Teleruttore BF.25	Remote switch	Contacteur	Schuetz	Teleruptor	Interruptor com controle remoto	
14	EP00900	1	Morsetto a vite	Terminal	Borne	Klemme	Borne	Grampo	10mm2
15	HE18800	1	Scheda	Card	Fiche	Schalttafel	Ficha	Ficha	
16	W3P4500	1	Dissipatore	Heatsink	Dissipateur	Wärmeableiter	Disipador de calor		
17	ED06400	1	Termostato	Thermostat	Thermostat	Thermostat	Termostato	Termostato	
18	ED02300	1	Termostato di sicurezza	Thermostat	Thermostat	Thermostat	Termostato	Termostato	
19	HS12020	1	Impianto elettrico completo	Wiring system complete	Système électrique complet	Elektrische Anlage komplett	Instalação eléctrica completa	Instalação eléctrica completa	
20	EH09000	1	Trasformatore	Transformer	Transformateur	Wandler	Transformador	Trasformador	60VA 230/24
21	ES22700	1	Ventola	Blower	Sufflerie	Geblaese	Pantalla	Ventoinha	

E.= Electronico, Electronic, Électronique, Elektronisch, Electrónico, Electrónico

M.= Meccanico, Mechanical, Mécanique, Mechanisch, Mecánico, Mecânico

3иt 06иcтpиk

vsezip.ru

+7(812)987-08-81

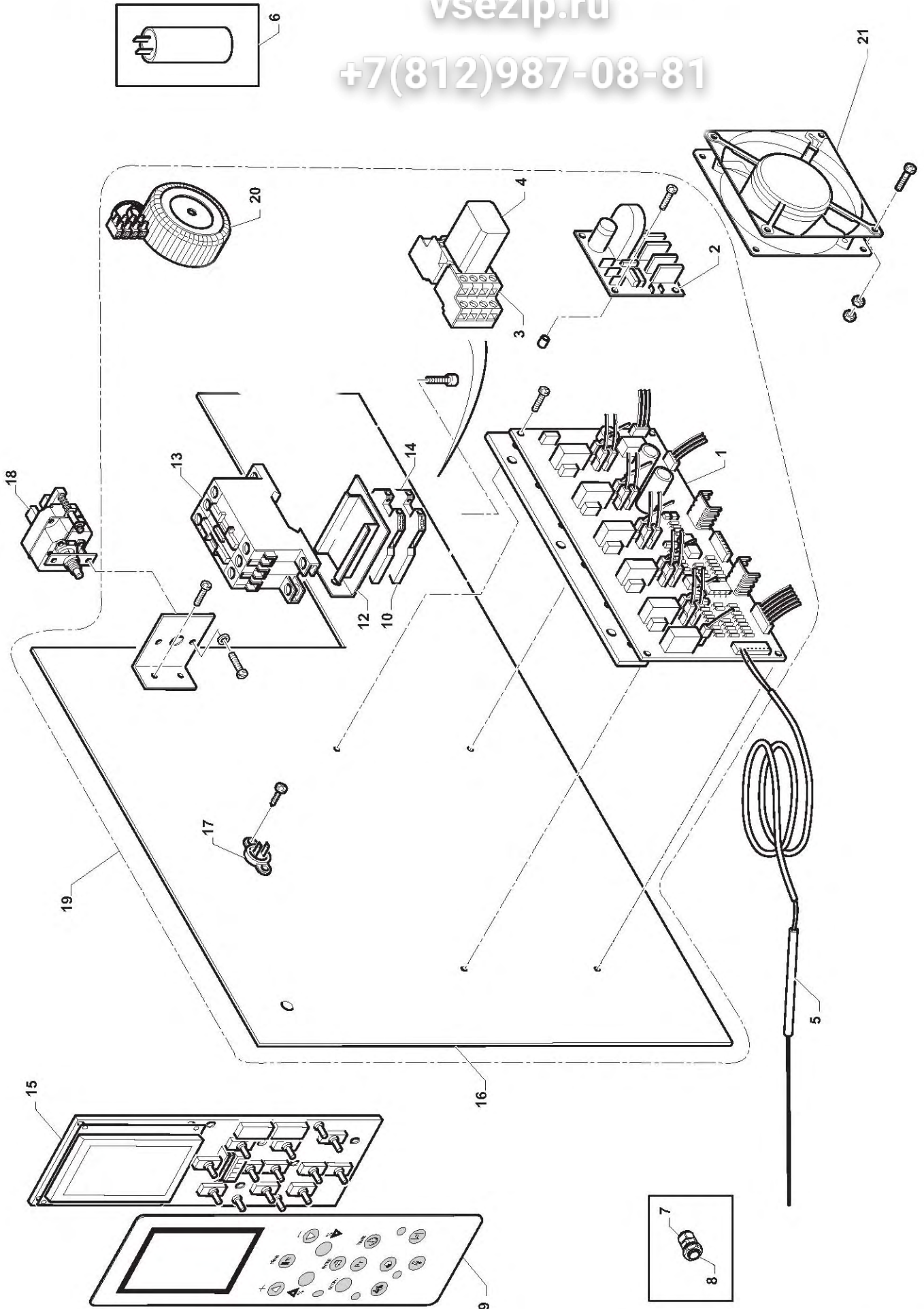

vsezip.ru

+7(812)987-08-81

Pos.	Cod.	Q.tà	ITA	GB	F	D	E	P	NOTE
1	A3W0500	1	Frontale cappa	Front	Frontal	Vorderteil	Parte frontal	Frontal	635XL
1	A3W0900	1	Frontale cappa	Front	Frontal	Vorderteil	Parte frontal	Frontal	935 - 635L
1	A3W1300	1	Frontale cappa	Front	Frontal	Vorderteil	Parte frontal	Frontal	435 - 635S
2	ACW2510	1	Complessivo filtro	Filter unit	Groupe du filtre	Filteraggregat	Conjunto filtro	Grupo filtro	
3	ABQ1500	1	Collettore cappa	Manifold	Collecteur	Kollektor	Colector	Colector	635XL
4	A3W0410	1	Retro cappa	Rear part	Partie postérieure	Rückteil	Parte de atrás	Parte posterior	935 - 635L
4	A3W1010	1	Retro cappa	Rear part	Partie postérieure	Rückteil	Parte de atrás	Parte posterior	435 - 635S
4	A3W1410	1	Retro cappa	Rear part	Partie postérieure	Rückteil	Parte de atrás	Parte posterior	
5	ACW7210	2	Staffa	Bracket	Etrier	Halter	Soporte	Estribo	
6	ES33000	1	Motore S/Regolatore di velocità	Motor/Regulator	Moteur/Régleur	Motor/Regler	Motor/Regulador	Motor/Regulador	
7	A3W0110	1	Fianco	Panel	Tableau	Tafel	Panel	Lado	des. / 435 - 635L - 635XL
7	A3W0610	1	Fianco	Panel	Tableau	Tafel	Panel	Lado	des. / 935 - 635S
8	A3W1510	1	Fianco	Panel	Tableau	Tafel	Panel	Lado	sin. / 435 - 635L - 635XL
8	A3W1610	1	Fianco	Panel	Tableau	Tafel	Panel	Lado	sin. / 935 - 635S
9	A3W0210	1	Pannello posteriore	Panel	Panneau	Schalttafel	Panel	Painél	635XL
9	A3W0710	1	Pannello posteriore	Panel	Panneau	Schalttafel	Panel	Painél	935 - 635L
9	A3W1110	1	Pannello posteriore	Panel	Panneau	Schalttafel	Panel	Painél	435 - 635S
10	A3W0310	1	Traversa cappa	Crossrail	Traverse	Traverse	Traversano	Travessa	635XL
10	A3W0810	1	Traversa cappa	Crossrail	Traverse	Traverse	Traversano	Travessa	935 - 635L
10	A3W1210	1	Traversa cappa	Crossrail	Traverse	Traverse	Traversano	Travessa	435 - 635S
11	QAC0800	1	Rosone cappe	Rose window	Élément cylindrique	Rosenfenster	Rosetón	Rosácea	
12	ACW4210	1	Piastra fissante rosone	Rose window fixing plate	Plaque de fixation	Platten	Chapa fijación rosetón	Chapa fixação rosácea	
13	HAT90R0	1	Tubo flessibile	Flexible exhaust	Tuyau	Schlauch	Manga	Tubo	D.80
14	AD00600	1	Pressacavo+viti	Cable pressing element+screws	Pressecâble+vis	Kabelpresselement +Schrauben	Sujetacable +tornillos	Prensa-cabo+parafusos	
15	ACW7410	2	Dischetto fissaggio	Disk	Plateau	Scheibe	Disco pequeño	Disquinho	

E.= Electronico, Electronic, Électronique, Elektronisch, Electrónico, Electrónico

M.= Meccanico, Mechanical, Mécanique, Mechanisch, Mecánico, Mecánico

vsezip.ru

+7(812)987-08-81

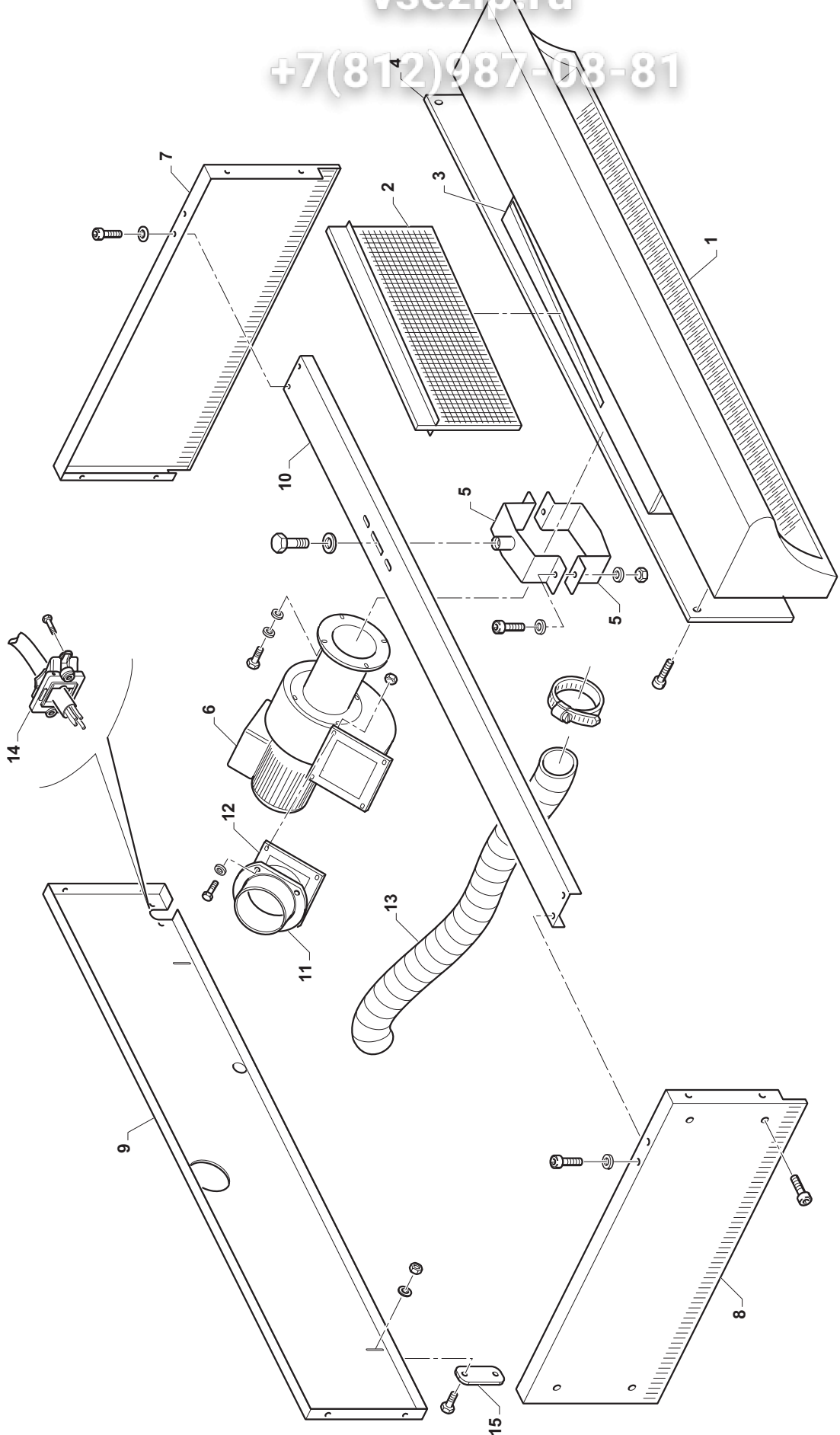

vsezip.ru

+7(812)987-08-81

Pos.	Cod.	Q.tà	ITA	GB	F	D	E	P	NOTE
1	B3T0020	2	Complessivo gamba	Leg assembly drawing	Vue d'ensemble de la jambe	Bein-Gesamt-Zeichnung	Conjunto pata	Conjunto pés	435 - 635L - 635XL
1	BWT8820	2	Complessivo gamba	Leg assembly drawing	Vue d'ensemble de la jambe	Bein-Gesamt-Zeichnung	Conjunto pata	Conjunto pés	635S - 935
2	B3L0120	4	Traversa supporto	Crossrail	Traverse	Traverse	Traversano	Traversa	635XL
2	B3L0220	4	Traversa supporto	Crossrail	Traverse	Traverse	Traversano	Traversa	435 - 635S
2	B3L0320	4	Traversa supporto	Crossrail	Traverse	Traverse	Traversano	Traversa	635L - 935
3	B3T0600	4	Piastra rinforzo supporto	Plate	Plaque	Traeger	Placa	Chapa	
4	B3T0720	4	Rinforzo gamba supporto	Reinforcement	Reinforcement	Verstaerkung	Refuerzo	Reforço	
5	B3T0500	2	Copertura frontale gamba	Cover	Couverture	Deck el	Cobertura	Cobertura	
6	AC068R0	2	Ruota senza freno	Wheel	Roue	Rad	Rueda	Roda	D.125 / 435
6	AC097R0	2	Ruota senza freno	Wheel	Roue	Rad	Rueda	Roda	D.125 / 935 - 635S - 635L - 635XL
7	AC080R0	2	Ruota senza freno	Wheel	Roue	Rad	Rueda	Roda	D.125 / 435
7	AC099R0	2	Ruota con freno	Wheel	Roue	Rad	Rueda	Roda	D.125 / 935 - 635S - 635L - 635XL
8	BWT2020	8/4	Alzata monocamera /bicamera	Rise	Elément de soulèvement	Aufsatz	Altura de elevación	Parte superior/vertical	
9	MD14700	4	Molletta	Grip	Epingle	Klammer	Pinza	Mola	

E.= Electronico, Electronic, Électronique, Elektronisch, Electrónico, Electrónico

M.= Meccanico, Mechanical, Mécanique, Mechanisch, Mecánico, Mecánico

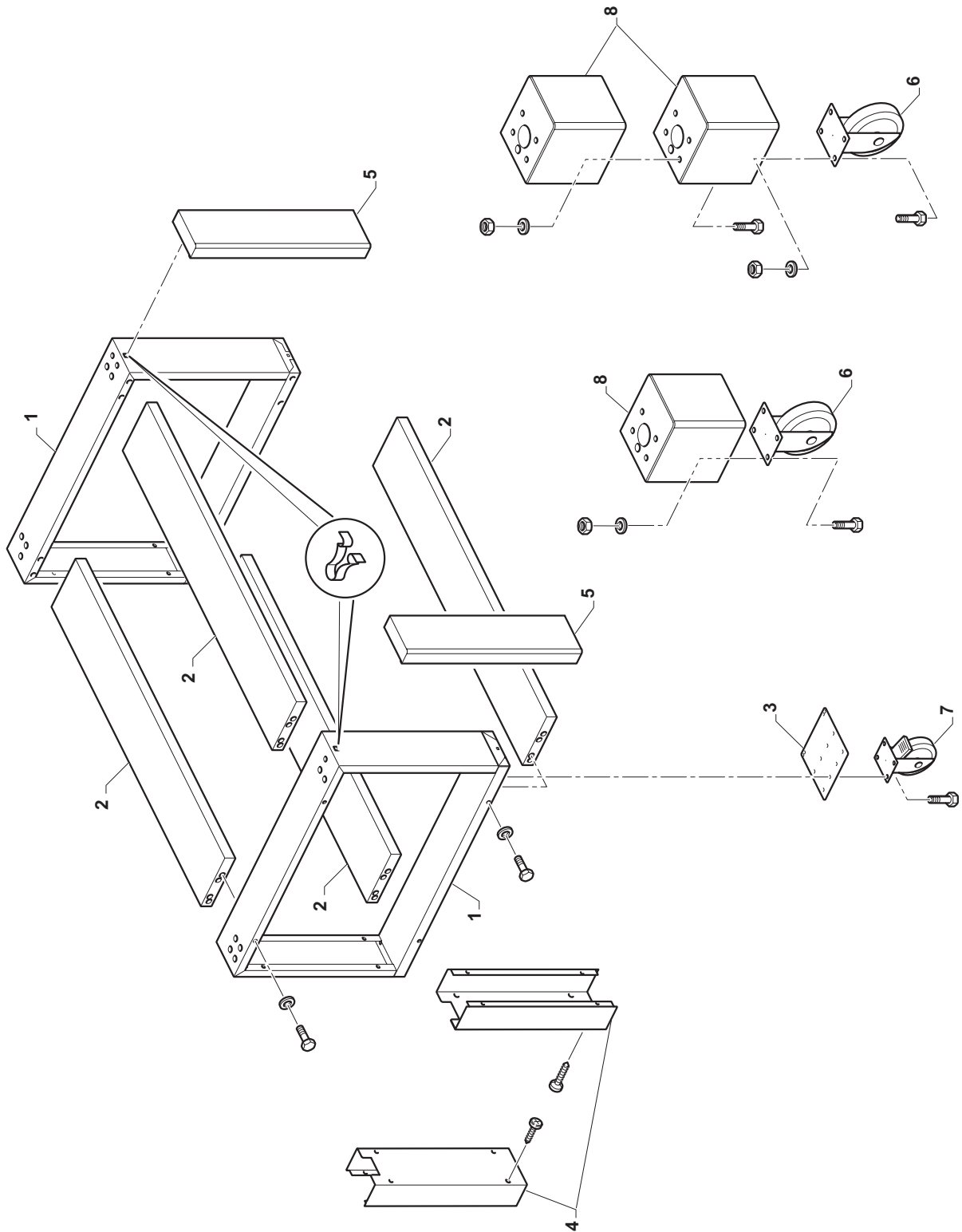

vsezip.ru

+7(812)987-08-81

Pos.	Cod.	Q.tà	ITA	GB	F	D	E	P	NOTE
1	B3P4110	1	Superiore cella	Upper part	Partie supérieure	Oberteil	Parte superior	Superior	635XL
1	B3P5100	1	Superiore cella	Upper part	Partie supérieure	Oberteil	Parte superior	Superior	935 - 635L
2	B3P4210	1	Posteriore cella	Rear part	Partie postérieure	Rückteil	Parte trasera	Posterior	635XL
2	B3P5200	1	Posteriore cella	Rear part	Partie postérieure	Rückteil	Parte trasera	Posterior	935 - 635L
3	B3P4910	1	Schienale	Back	Dossier	Rueckenlehne	Respaldo	Parte traseira	635XL
3	B3P5400	1	Schienale	Back	Dossier	Rueckenlehne	Respaldo	Parte traseira	935 - 635L
4	B3P4410	1	Traversa pannello comandi	Crossrail	Traverse	Traverse	Traversano	Traversa	635XL
4	B3P5300	1	Traversa pannello comandi	Crossrail	Traverse	Traverse	Traversano	Traversa	935 - 635L
5	B3P6110	1	Protezione impianto elettrico	Shield	Protection	Abdeckung	Defensa	Proteção	
6	BQP0110	20	Guida cella	Guide	Glissier	Fuehrung	Guia	Guia	
7	B3P5911	2	Chiusura laterale	Closing	Fermeture	Verschluss	Cierre	Fecho	935
7	B3P6011	2	Chiusura laterale	Closing	Fermeture	Verschluss	Cierre	Fecho	635L - 635XL
8	B3K0120	4	Perno porta	Pin	Axe	Bolzen	Eje	Perno	
9	BQP2110	2	Porta cella	Door	Porte	Tuer	Puerta	Porta	
10	AD00600	1	Pressacavo+viti	Cable pressing element+screws	Pressecâble +vis	Kabelpresselement +Schrauben	Sujetacable +tornillos	Prensa-cabo +parafusos	
11	ED07700	1	Termostato	Thermostat	Thermostat	Thermostat	Termostato	Termostato	
12	EF00400	1	Interruttore	Switch	Interrupteur	Schalter	Interruptor	Interruptor	
13	50MAA78022	1	Tappo nero	Plug	Bouchon	Stopfen	Tapon	Tampa	
14	ED06500	1	Termocoppia	Thermocouple	Thermocouple	Thermoelement	Termopar	Termo-par	
15	EE22300	4	Resistenza	Resistor	Resistance	Widerstand	Resistencia	Resistência	W.300 V.230
16	AC10300	4	Cricchetti magnetici	Magnetic ratchets	Cliquets magnétiques	Magnetsperiklinken	Trinquetes magnéticos	Fechos magnéticos	
17	BQK0210	2	Piastrina perno porta	Plate	Plaque	Plattchen	Placa	Plaqueta	
18	B3P4700	1	Copertura centrale frontale	Cover	Couverture	Deck el	Cobertura	Cobertura	635XL
18	B3P5710	1	Copertura centrale frontale	Cover	Couverture	Deck el	Cobertura	Cobertura	935 - 635L

E.= Electronico, Electronic, Électronique, Elektronisch, Electrónico, Electrónico

M.= Meccanico, Mechanical, Mécanique, Mechanisch, Mecánico, Mecánico

vsezip.ru

+7(812)987-08-81

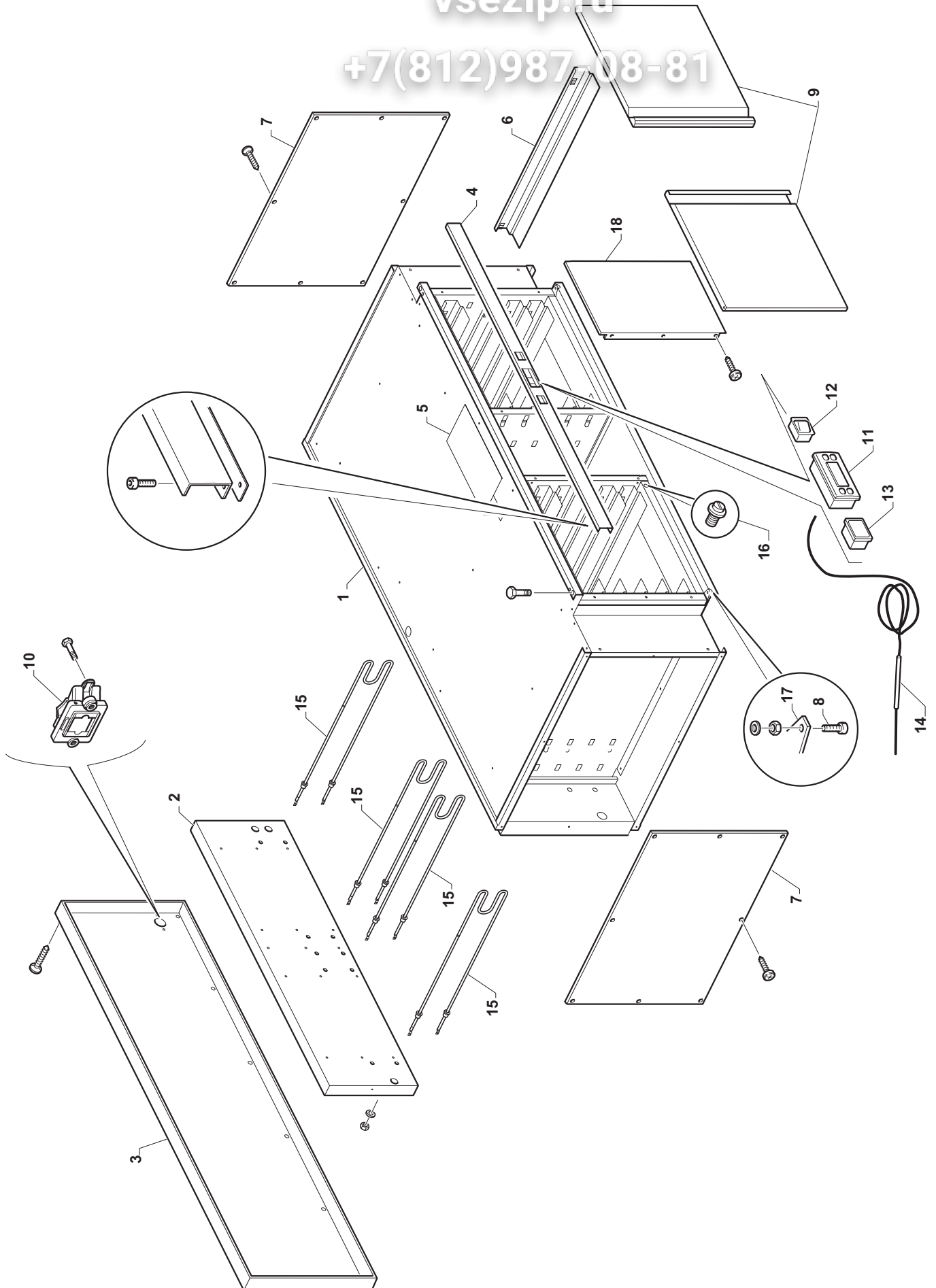

Pos.	Cod.	Q.tà	ITA	GB	F	D	E	P	NOTE
1	B3P6700	1	Superiore cella	Upper part	Partie supérieure	Oberteil	Parte superior	Superior	
2	B3P6600	1	Posteriore cella	Rear part	Partie postérieure	Rückteil	Parte trasera	Posterior	
3	B3P6400	1	Schienale cella	Back	Dossier	Rueckenlehne	Respaldo	Parte traseira	
4	B3P6510	1	Traversa pannello comandi	Crossrail	Traverse	Traverse	Traversano	Travessa	V.230
5	B3P6110	1	Protezione impianto elettrico	Shield	Protection	Abdeckung	Defensa	Proteção	
6	BQP0110	10	Guida cella	Guide	Glissier	Fuehrung	Guia	Guia	
7	B3P5911	1	Chiusura laterale	Closing	Fermeture	Verschluss	Cierre	Fecho	635S
7	B3P6011	1	Chiusura laterale	Closing	Fermeture	Verschluss	Cierre	Fecho	435
8	B3K0120	2	Perno porta	Pin	Axe	Bolzen	Eje	Perno	
9	BQP2110	1	Porta cella	Door	Porte	Tuer	Puerta	Porta	
10	AD00600	1	Pressacavo+viti	Cable pressing element+screws	Pressécâble +vis	Kabelpresselement +Schrauben	Sujetacable +tornillos	Prensa-cabo +parafusos	
11	ED07700	1	Termostato	Thermostat	Thermostat	Thermostat	Termostato	Termostato	
12	EF00400	1	Interruttore	Switch	Interrupteur	Schalter	Interruptor	Interruptor	
13	50MAA78022	1	Tappo nero	Plug	Bouchon	Stopfen	Tapon	Tampa	
14	ED06500	1	Termocoppia	Thermocouple	Thermocouple	Thermoelement	Termopar	Termo-par	
15	EE22300	2	Resistenza	Resistor	Resistance	Widerstand	Resistencia	Resistencia	W.300 V.230
16	AC10300	2	Cricchetti magnetici	Magnetic ratchets	Cliquets magnétiques	Magnetsperklinen	Trinquetes magnéticos	Fechos magnéticos	
17	BQK0210	1	Piastrina perno porta	Plate	Plaque	Plättchen	Placa	Plaqueta	

vsezip.ru
+7(812)987-08-81

E.= Electronico, Electronic, Électronique, Elektronisch, Electrónico, Electrónico

M.= Meccanico, Mechanical, Mécanique, Mechanisch, Mecánico, Mecánico

3m-06.ru

vsezip.ru

+7(812)987-08-81

