

Зип Общепит

vsezip.ru

+7(812)987-08-81

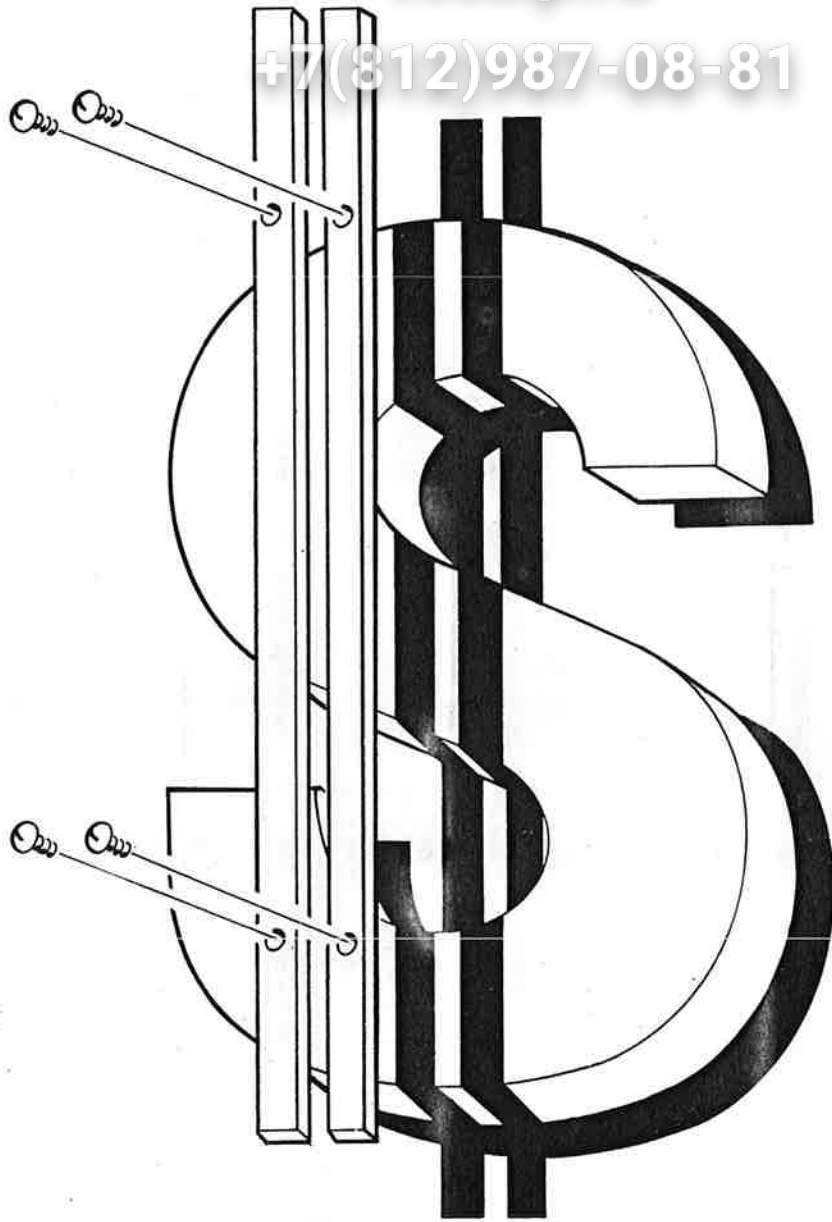

E elettrobar

Зип Общепит
vsezip.ru

+7(812)987-08-81

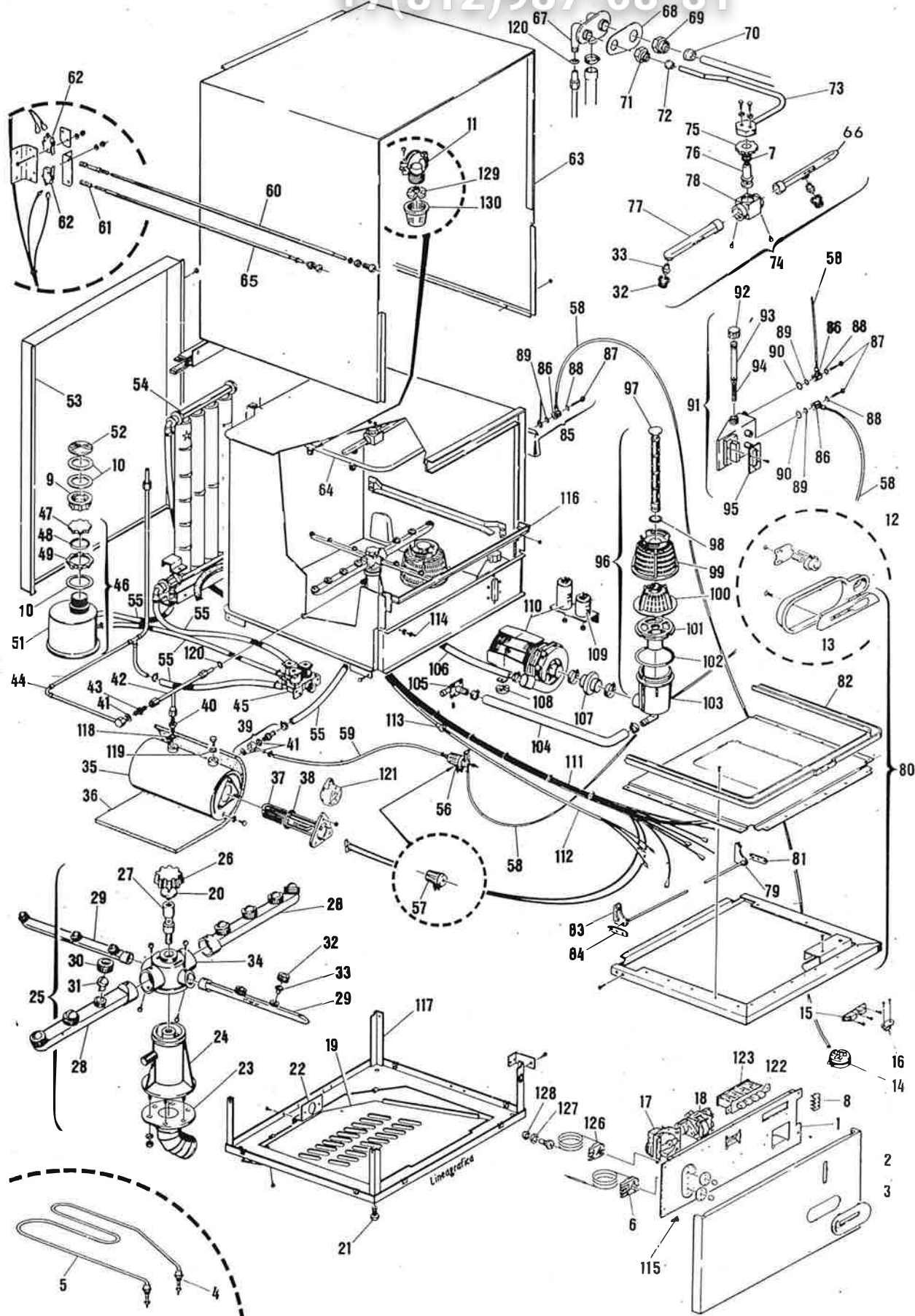

POS	CODICE CODE KODE
1	{ 02 40 01
	{ 02 40 02
2	01 20 01
3	{ 40 40 01
	{ 40 40 02
4	43 70 22
5	{ 23 00 09
	{ 23 00 17
6	23 60 04
7	43 70 08
8	22 00 04
9	42 90 12
10	43 70 34
11	11 00 01
12	44 70 37
13	44 70 36
14	22 40 03
15	99 40 01
16	12 30 02
17	pag. 49
18	pag. 49
19	03 00 01
20	45 40 02
21	46 10 10
22	03 30 04
23	12 70 12
24	11 50 02
25	99 00 08
26	44 70 30
27	32 70 06
28	{ 10 60 09
	{ 10 60 12

POS.	CODICE CODE KODE
29	{ 10 60 11
	{ 10 60 10
30	42 90 07
31	14 00 08
32	42 90 06
33	14 00 07
34	12 90 03
35	98 20 06
36	41 30 02
37	{ 23 00 12
	{ 23 00 25
	{ 23 00 23
38	45 60 02
39	99 10 01
40	46 80 05
41	43 70 07
42	46 80 27
43	46 80 03
44	{ 11 50 06
	{ 11 50 07
45	pag. 53
46	40 69 99
47	48 00 05
48	45 60 16
49	42 90 11
52	48 00 06
53	{ 02 20 03
	{ 02 20 07
54	pag. 162
55	14 30 04
56	{ 98 70 01
	{ 98 70 05

POS.	CODICE CODE KODE
57	{ 20 10 02
	{ 20 10 11
58	14 30 13
59	14 30 05
60	{ 98 10 02
	{ 41 00 01
	{ 44 90 08
61	44 90 07
62	21 80 02
63	{ 01 00 01
	{ 01 00 02
64	99 00 26
65	{ 98 10 01
	{ 44 90 07
66	pag. 163
67	11 10 01
68	43 70 37
69	41 70 38
70	44 10 10
71	41 70 39
72	44 10 09
73	11 50 05
74	pag. 163
75	42 90 08
76	32 50 01
77	pag. 163
78	12 90 02
79	31 10 01
80	{ 02 90 01
	{ 02 90 08
81	30 70 01
82	{ 32 80 03
	{ 32 80 01

POS.	CODICE CODE KODE
83	31 10 02
84	30 70 02
85	98 40 01
86	46 80 53
87	48 60 02
88	45 60 06
89	45 60 06
90	pag. 161
91	pag. 161
92	48 00 04
93	10 90 02
94	44 90 05
95	43 70 36
96	98 60 01
97	14 20 08
98	45 60 10
99	12 10 14
100	12 10 16
101	42 90 13
102	45 60 01
103	13 60 02
104	12 70 05
105	13 60 04
106	12 70 01
107	12 70 13
108	47 20 27
109	21 20 01
110	pag. 55
111	{ 20 30 17
	{ 20 30 15

POS.	CODICE CODE KODE
112	20 40 06
113	45 90 01
114	46 20 01
115	49 90 07
116	32 80 06
117	04 00 06
118	43 70 42
119	43 70 05
120	45 60 11
121	46 70 02
122	pag. 69
123	pag. 69
126	23 60 03
127	43 70 02
128	41 70 17
129	pag. 160
130	pag. 160
131	46 80 25
132	31 90 02
133	32 20 04
134	49 90 18
135	11 50 04
136	47 80 17
137	03 30 36
138	10 60 03
139	13 30 03
140	10 60 01
141	14 00 07
142	42 90 06
143	14 00 08
144	42 90 07
145	99 00 12
146	11 00 01

POS.	CODICE CODE KODE
147	
148	

+7(812)987-08-81

vsezip.ru

Зип-Общепит

vsezip.ru

+7(812)987-08-81

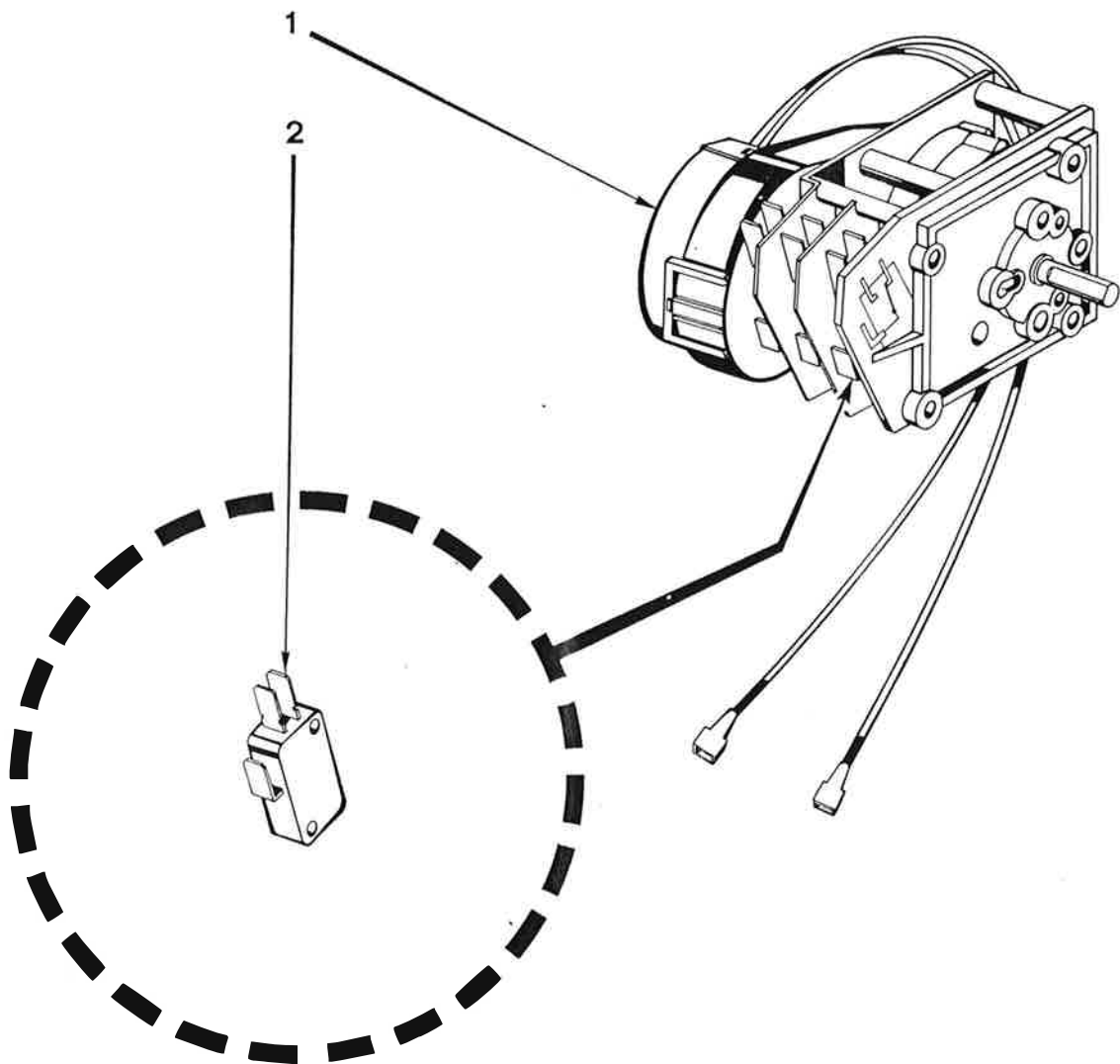

POS.	CODICE CODE KODE	DESCRIZIONE - DESCRIPTION - BESCHREIBUNG					
1	23 80 12	Timer ciclo 108" - Cronel 3C Cycle timer 108" - Cronel 3C Programmateur cycle 108" - Cronel 3C Programmschalter 108" - Cronel 3C	220/50/1	Mod. S 621 - 623 - 624 - 626 - 631 - 633 - 634 - 636 - 651 - 653 - 654 - 655	1	23 80 02	Timer ciclo 1' 2' Cycle timer 1' 2' Programmateur 1' Programmschalter
1	23 80 26	Timer ciclo 108" - Crouzet 2C Cycle timer 108" - Crouzet 2C Programmateur cycle 108" - Crouzet 2C Programmschalter 108" - Crouzet 2C	220/50/1	Mod. S 621 - 623 - 624 - 626 - 631 - 633 - 634 - 636 - 651 - 653 - 654 - 655	1	23 80 30	Timer ciclo 3' 6' Cycle timer 3' 6' Programmateur 3' Programmschalter
1	23 80 07	Timer ciclo 108" - Cronel 3C Cycle timer 108" - Cronel 3C Programmateur cycle 108" - Cronel 3C Programmschalter 108" - Cronel 3C	240/50/1	Mod. S 621 - 623 - 624 - 626 - 631 - 633 - 634 - 636 - 651 - 653 - 654 - 655	1	23 80 21	Timer ciclo 5' - C Cycle timer 5' - C Programmateur 5' Programmschalter
1	23 80 33	Timer ciclo 150" - Cronel 3C Cycle timer 150" - Cronel 3C Programmateur cycle 150" - Cronel 3C Programmschalter 150" - Cronel 3C	220/50/1	Mod. S 621 - 623 - 624 - 626 - 631 - 633 - 634 - 636 - 651 - 653 - 654 - 655	1	23 80 11	Timer rigenerazio Regeneration timer Programmateur re Regenerationssch
1	23 80 36	Timer ciclo 150" - Crouzet 2C Cycle timer 150" - Crouzet 2C Programmateur cycle 150" - Crouzet 2C Programmschalter 150" - Crouzet 2C	220-240/50/1	Mod. S 621 - 623 - 624 - 626 - 631 - 633 - 634 - 636 - 651 - 653 - 654 - 655	1	23 80 06	Timer rigenerazio Regeneration timer Programmateur re Regenerationssch
1	23 80 41	Timer ciclo 150" - Cronel 3C Cycle timer 150" - Cronel 3C Programmateur cycle 150" - Cronel 3C Programmschalter 150" - Cronel 3C	240/50/1	Mod. S 621 - 623 - 624 - 626 - 631 - 633 - 634 - 636 - 651 - 653 - 654 - 655	1	23 80 27	Timer rigenerazio Regeneration timer Programmateur re Regenerationssch
1	23 80 03	Timer ciclo 108"/168" - Cronel 4C Cycle timer 108"/168" - Cronel 4C Programmateur cycle 108"/168" - Cronel 4C Programmschalter 108"/168" - Cronel 4C	220-240/50/1	Mod. S 651/P - 810 - 815 - 830 - 835	1	23 80 10	Timer pompa sca Drain pump timer Programmateur p Laugenpumpe-Pr
1	23 80 17	Timer ciclo 108"/168" - Cronel 4C Cycle timer 108"/168" - Cronel 4C Programmateur cycle 108"/168" - Cronel 4C Programmschalter 108"/168" - Cronel 4C	220/60/1	Mod. S 651/P - 810 - 815 - 830 - 835	1	23 80 08	Timer pompa sca Drain pump timer Programmateur p Laugenpumpe-Pr
					1	23 80 20	Timer pompa sca Drain pump timer Programmateur p Laugenpumpe-Pr
					1	21 80 09	Micro timer Cronel Microtimer Cronel Minirupteur progr Mikroschalter Cro

Зип Общепит

vsezip.ru

+7(812)987-98-81

vsezip.ru

+7(812)987-08-81

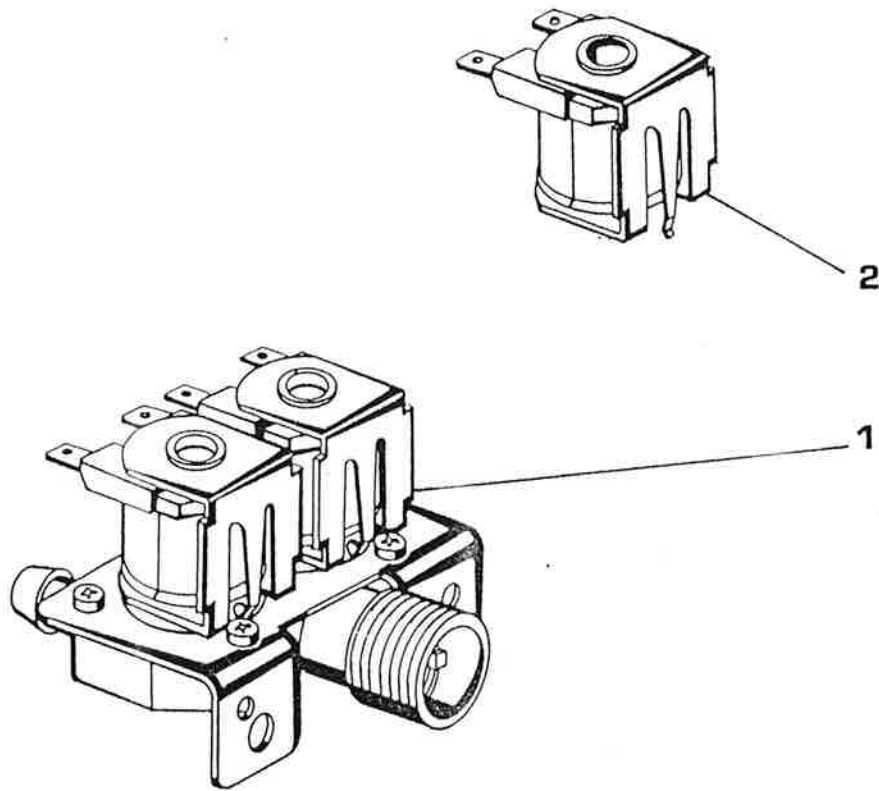

3 вт. Общепит
 vsezip.ru
 +7(812)987-08-81

POS.	CODICE CODE KODE	DESCRIZIONE - DESCRIPTION - BESCHREIBUNG
1	24 00 05	Valvola - Elbi - 1 via 180° Solenoid valve - Elbi - 1 way 180° Vanne - Elbi - 1 bobine 180° Einweg - Einlassmagnetventil - Elbi - 180° 220-240/50-60/1 Mod. S 651/P - 655 Mod. S 830 - 835 fino matricola n° 80211 till serial no. 80211 au matricule n° 80211 bis Maschinen-Nr. 80211
1	24 00 03	Valvola - 2 vie 180° Solenoid valve - 2 ways 180° Vanne - 2 bobines 180° Zweiweg - Einlassmagnetventil - 180° 220-240/50-60/1 Mod. S 621 - 624 - 631 - 634 - 651 - 654 - 810 - 815 - 850 - 950 Mod. S 830 - 835 da matricola n° 80212 from serial no. 80212 du matricule n° 80212 ab Maschinen-Nr. 80212 Mod. S 870 da matricola n° 64903 from serial no. 64903 du matricule n° 64903 ab Maschinen-Nr. 64903
1	24 00 02	Valvola - 3 vie 180° Solenoid valve - 3 ways 180° Vanne - 3 bobines 180° Dreiweg - Einlassmagnetventil - 180° 220-240/50-60/1 Mod. S 623 - 626 - 633 - 636 - 653
2	20 10 06	Bobina valvola Coil for solenoid valve Bobine pour vanne Spule für Einlassmagnetventil

POMPA
WASH PUMP
POMPE
ELEKTROPUMPE

mod. S:
621 - 623 - 624 - 626
631 - 633 - 634 - 636

55

10/87

Зип.Общепит
vsezip.ru

+7(812)987-08-81

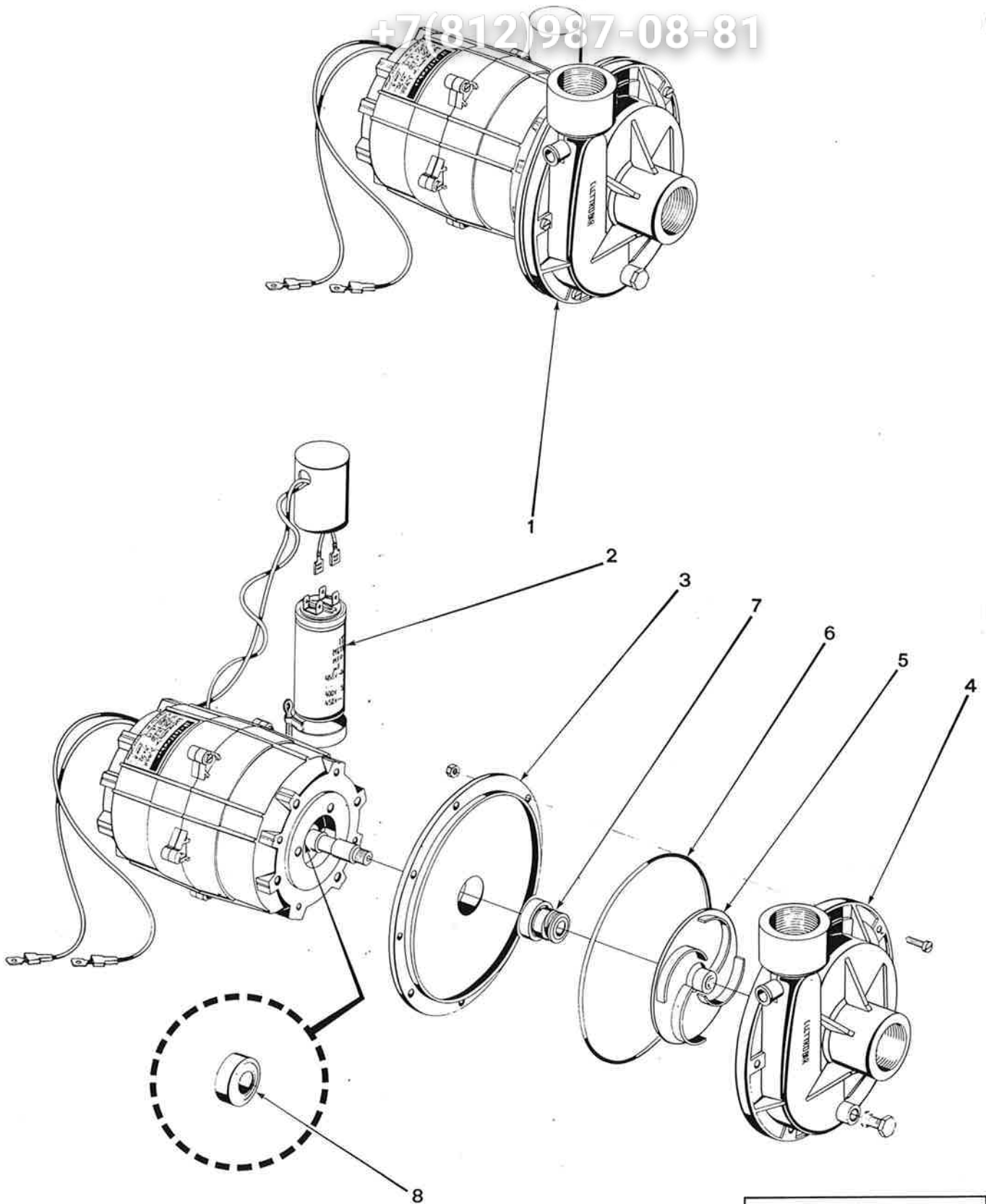

E3 wolk

POMPA
WASH PUMP
POMPE
ELEKTROPUMPE

mod. S:
621 - 623 - 624 - 626
631 - 633 - 634 - 636

56

16/67

Зип Общежит

vsezip.ru

+7(812)987-08-81

POS.	CODICE CODE KODE	DESCRIZIONE - DESCRIPTION - BESCHREIBUNG
1	13 00 08	Pompa - Olimpia T 30 HP 0,4 Wash pump - Olimpia T 30 HP 0,4 Pompe - Olimpia T 30 HP 0,4 Elektropumpe - Olimpia T 30 HP 0,4
1	13 00 07	Pompa - Olimpia T 30 HP 0,4 Wash pump - Olimpia T 30 HP 0,4 Pompe - Olimpia T 30 HP 0,4 Elektropumpe - Olimpia T 30 HP 0,4
1	13 00 32	Pompa - Olimpia T 30 HP 0,4 Wash pump - Olimpia T 30 HP 0,4 Pompe - Olimpia T 30 HP 0,4 Elektropumpe - Olimpia T 30 HP 0,4
1	13 00 26	Pompa - FIR 1297 HP 0,4 Wash pump - FIR 1297 HP 0,4 Pompe - FIR 1297 HP 0,4 Elektropumpe - FIR 1297 HP 0,4
1	13 00 01	Pompa - FIR 1297 HP 0,4 Wash pump - FIR 1297 HP 0,4 Pompe - FIR 1297 HP 0,4 Elektropumpe - FIR 1297 HP 0,4
2	20 60 01	Condensatore T 30 - FIR 1297 Condenser T 30 - FIR 1297 Condensateur T 30 - FIR 1297 Kondensator T 30 - FIR 1297
3	31 50 06	Flangia T 30 - FIR 1297 Flange int. T 30 - FIR 1297 Flansque int. T 30 - FIR 1297 Flasch T 30 - FIR 1297
4	11 60 08	Corpo pompa T 30 - FIR 1297 Flange ext. T 30 - FIR 1297 Flansque ext. T 30 - FIR 1297 Pumpengehäuse T 30 - FIR 1297
5	12 40 06	Girante 50 Hz. T 30 - FIR 1297 Impeller 50 Hz. T 30 - FIR 1297 Turbine 50 Hz. T 30 - FIR 1297 Pumpenflügel 50 Hz. T 30 - FIR 1297



POMPA
WASH PUMP
POMPE
ELEKTROPUMPE

mod. S:
621 - 623 - 624 - 626
631 - 633 - 634 - 636

POS.	CODICE CODE KODE	
5	12 40 17	Girante Impeller Turbine Pumpenflügel
6	45 60 31	OR T 30 O-ring T 30 Joint the O-Ring
7	14 10 02	Tenuta Seal T 30 Presse Gleitring
8	31 40 01	Cuscine Bearing Roulement Kugellager
8	31 40 02	Cuscine Bearing Roulement Kugellager

+7(812)987-08-81

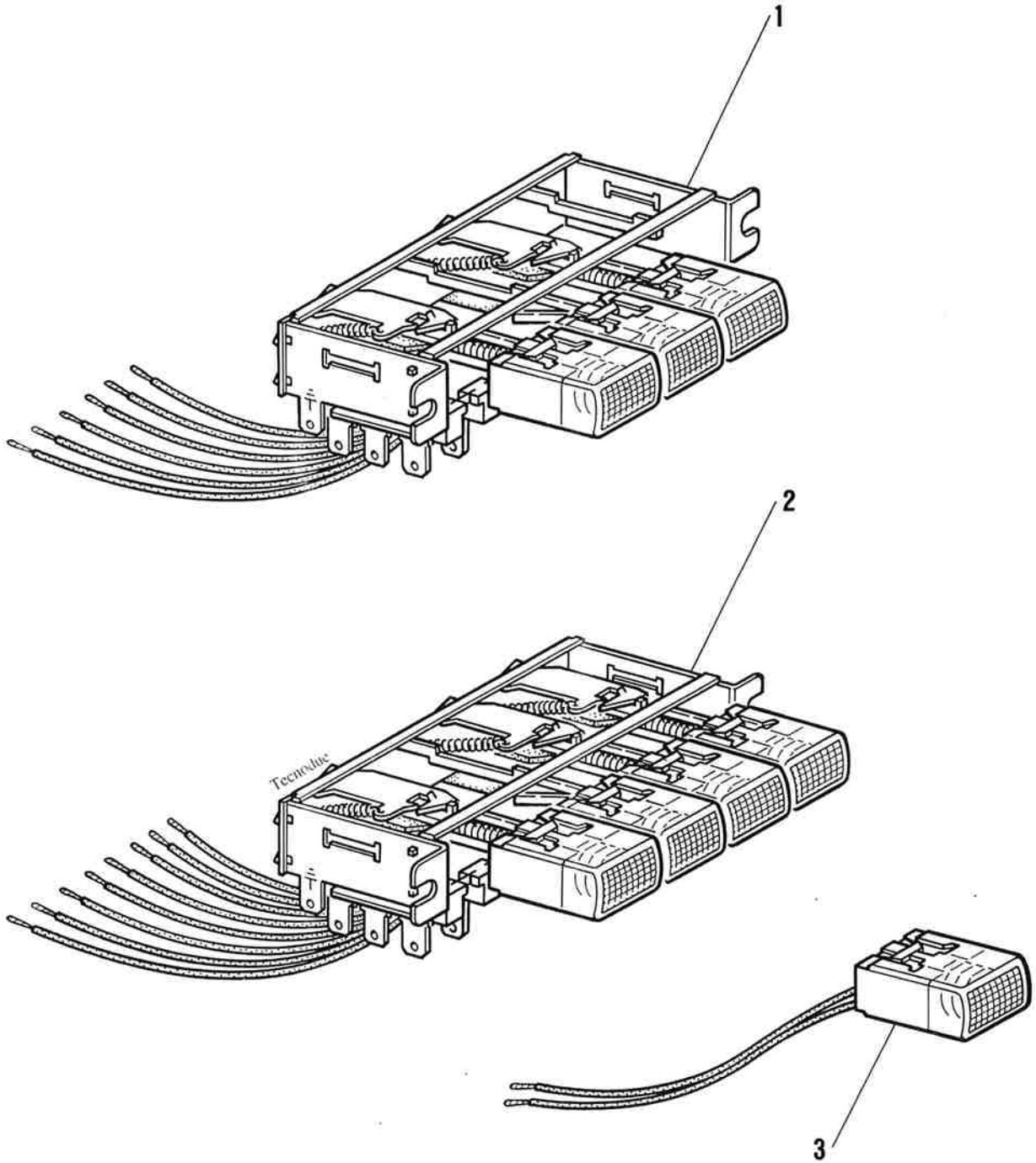

POS.	CODICE CODE KODE	DESCRIZIONE - DESCRIPTION - BESCHREIBUNG
1	22 70 02	<p>Pulsantiera 3 pulsanti Keyboard 3 push buttons Clavier 3 boutons Bedienungsschalter 3 Schalter</p> <p>Mod. S 830 da matricola n° 80212 from serial no. 80212 du matricule n° 80212 ab Maschinen-Nr. 80212</p> <p>Mod. S 950 fino matricola n° 81059 till serial no. 81059 au matricule n° 81059 bis Maschinen-Nr. 81059</p>
2	22 70 03	<p>Pulsantiera 4 pulsanti Keyboard 4 push buttons Clavier 4 boutons Bedienungsschalter 4 Schalter</p> <p>Mod. S 623 - 626 - 633 - 636 - 651/P - 653 - 655</p> <p>Mod. S 830 fino matricola n° 80211 till serial no. 80211 au matricule n° 80211 bis Maschinen-Nr. 80211</p> <p>Mod. S 850 fino matricola n° 81936 till serial no. 81936 au matricule n° 81936 bis Maschinen-Nr. 81936</p>
2	22 70 03	<p>Pulsantiera 4 pulsanti - Pompa scarico Keyboard 4 push buttons - Drain pump Clavier 4 boutons - Pompe vidange Bedienungsschalter 4 Schalter - Laugenpumpe</p> <p>Mod. S 621 - 624 - 631 - 634 - 651 - 654 - 810 - 835</p>
2	22 70 01	<p>Pulsantiera 4 pulsanti Keyboard 4 push buttons Clavier 4 boutons Bedienungsschalter 4 Schalter</p> <p>Mod. S 850 da matricola n° 81937 till serial no. 81937 du matricule n° 81937 ab Maschinen-Nr. 81937</p> <p>Mod. S 950 da matricola n° 81060 from serial no. 81060 du matricule n° 81060 ab Maschinen-Nr. 81060</p>
2	22 70 01	<p>Mod. S 870 da matricola n° 64903 from serial no. 64903 du matricule n° 64903 ab Maschinen-Nr. 64903</p>

POS.	CODICE CODE KODE	DESCRIZIONE - DESCRIPTION - BESCHREIBUNG
3	22 60 05	<p>Pulsante arancina Orange push button Bouton orange Orange Schalter</p>
3	22 60 06	<p>Pulsante bianca White push button Bouton blanc Weisse Schalter</p>
3	22 60 07	<p>Pulsante verde Green push button Bouton vert Grüne Schalter</p>
3	22 60 08	<p>Pulsante gialla Yellow push button Bouton jaune Gelbe Schalter</p>

Эл.Общепит

vsezip.ru

+7(812)987-08-81

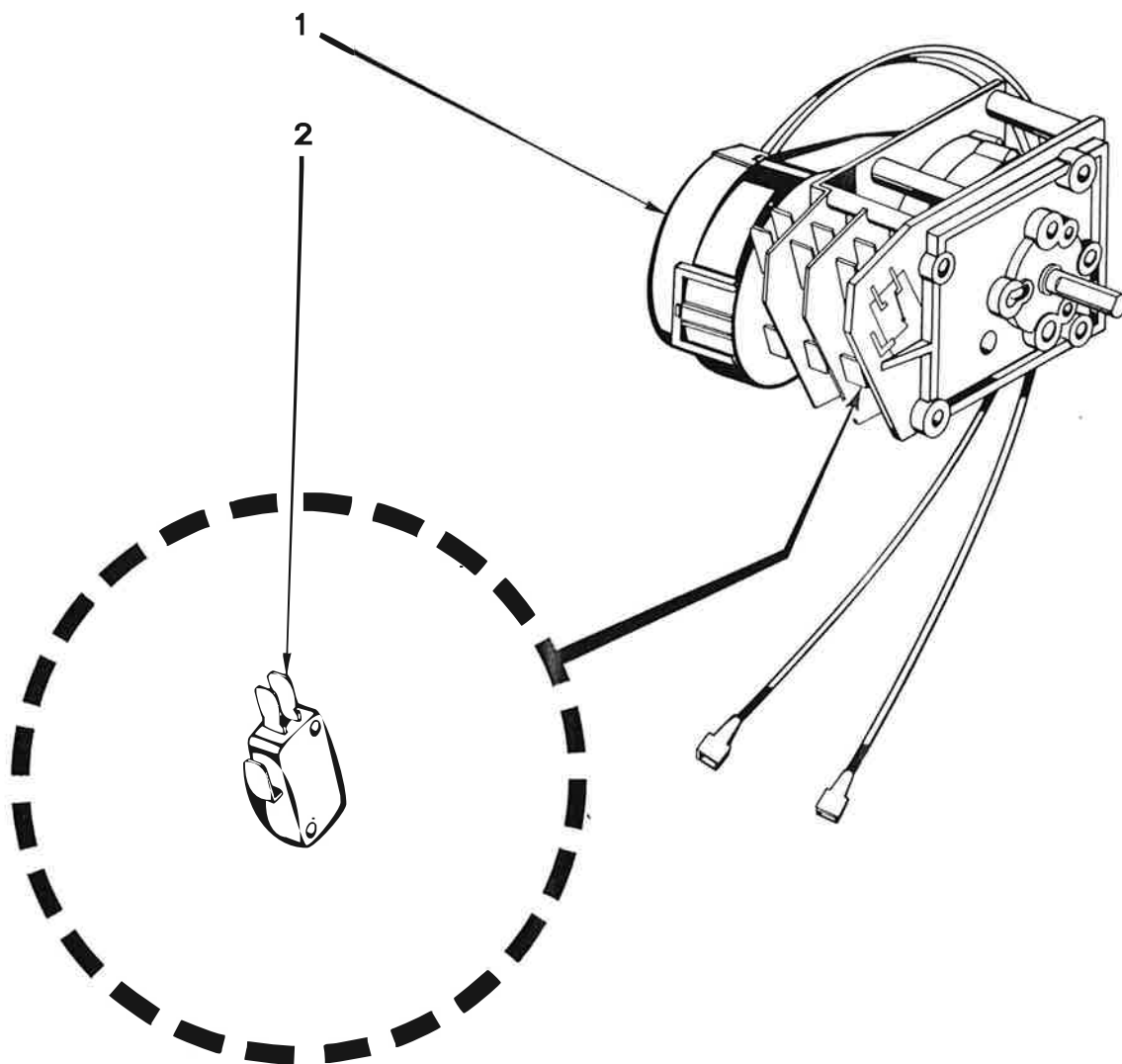

E3 wolk

Timer serie «R» - Timer «R» range

Programmateur serie «R» - Programmschalter Serie «R»

91

10/87

Q.S.	CODICE CODE KODE	DESCRIZIONE - DESCRIPTION - BESCHREIBUNG
1	23 80 25	Timer ciclo 180" - Cronel 2C Cycle timer 180" - Cronel 2C Programmateur cycle 180" - Cronel 2C Programmschalter 180" - Cronel 2C
1	23 80 01	Timer ciclo 180" - Crouzet 3C Cycle timer 180" - Crouzet 3C Programmateur cycle 180" - Crouzet 3C Programmschalter 180" - Crouzet 3C
1	23 80 24	Timer ciclo 180" - Cronel 3C Cycle timer 180" - Cronel 3C Programmateur cycle 180" - Cronel 3C Programmschalter 180" - Cronel 3C
1	23 80 05	Timer ciclo 180" - Cronel 3C Cycle timer 180" - Cronel 3C Programmateur cycle 180" - Cronel 3C Programmschalter 180" - Cronel 3C
1	23 80 16	Timer ciclo 180" - Cronel 3C Cycle timer 180" - Cronel 3C Programmateur cycle 180" - Cronel 3C Programmschalter 180" - Cronel 3C

E3 wolkTimer serie «R»
Programmateur

POS.	CODICE CODE KODE	
1	23 80 09	Timer pompa Drain pump t Programmate Laugenpump
2	21 80 09	Micro timer C Microtimer C Minirupteur p Mikroschalter

Этп Общепит

vsezip.ru

+7(812)987-08-81

+7(812)987-08-81

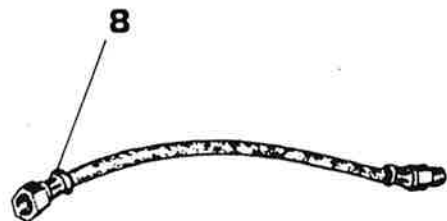
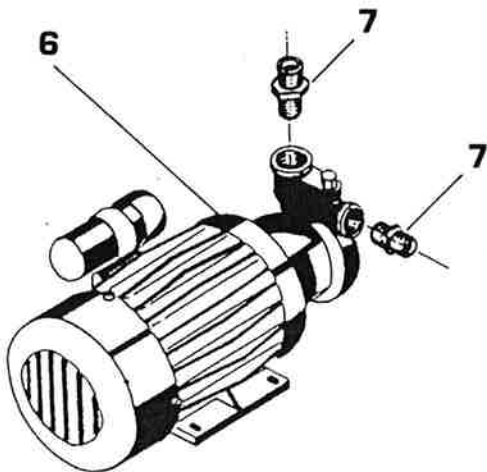
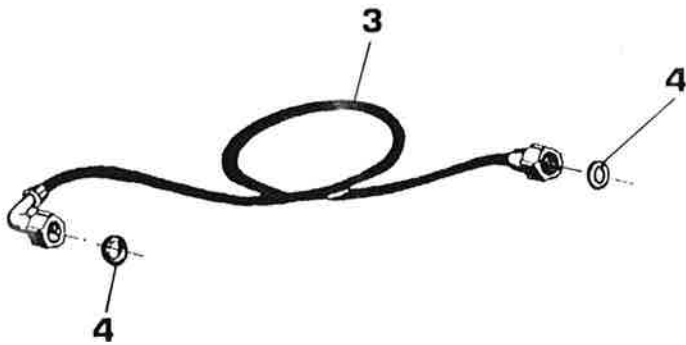
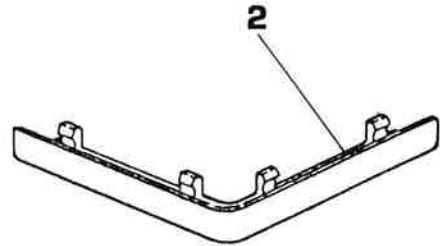

POS.	CODICE CODE KODE	DESCRIZIONE - DESCRIPTION - BESCHREIBUNG	POS.	CODICE CODE KODE	
1	70 20 02	Anello cesto ø 33 Rack ring ø 33 Volant panier ø 33 Körbring ø 33	5	14 30 19 *	Tubo scarico Drain pipe ø 22 Tuyau vidange ø 22 Ablaufschlauch ø 22
1	70 20 01	Anello cesto ø 38 Rack ring ø 38 Volant panier ø 38 Körbring ø 38	5	14 30 20 *	Tubo scarico Drain pipe ø 38 Tuyau vidange ø 38 Ablaufschlauch ø 38
2	46 10 03	Piedino cesto grigio Grey rack feet Pied panier gris Grauer Korbfuss	6	pag. 115	Pompa ausilia Rinse booster Pompe de rinçage Nachspülpumpe
3	14 30 16 *	Tubo carico con curva 3/4 gas Inlet pipe with bend 3/4 gas Tuyau alimentation avec courbe 3/4 gaz Zulaufschlauch mit Kurve 3/4 Gas	7	46 80 26	Raccordo pom Rinse booster Raccord pomp Nachspülpumpe
3	14 30 18 *	Tubo carico 19 x 26 Inlet pipe 19 x 26 Tuyau alimentation 19 x 26 Zulaufschlauch 19 x 26	8	14 30 21	Tubo flessibile Rinse booster Tuyau flexible Nachspülpumpe
4	43 70 41	Guarnizione carico 3/4 gas Inlet gasket 3/4 gas Joint alimentation 3/4 gaz Zulaufdichtung 3/4 Gas			
5	14 30 17	Tubo scarico Mt. 1,5 ø 22 Drain pipe mt. 1,5 ø 22 Tuyau vidange mt. 1,5 ø 22 Ablaufschlauch Mt. 1,5 ø 22			Modelli con pompa scarico Models with drain pump Modèles avec tuyau vidange Modelle mit Laugenpumpe

Этот Общепит

vsezip.ru

+7(812)987-08-81

www.Общественный
vsezip.ru

+7(812)987-08-81

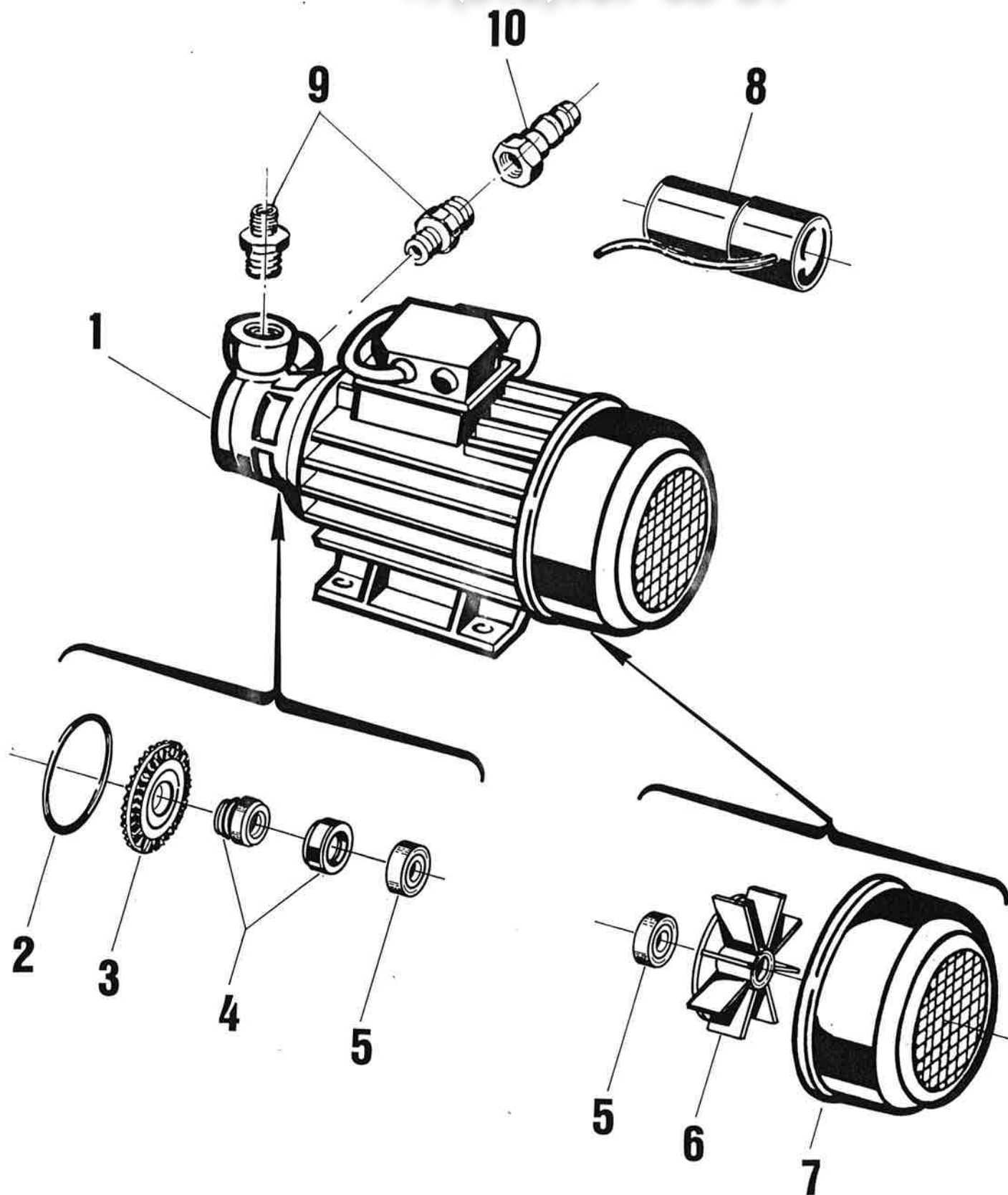

DESCRIZIONE - DESCRIPTION - BESCHREIBUNG

+7(812)987-08-81

POS.	CODICE CODE KODE	DESCRIZIONE - DESCRIPTION - BESCHREIBUNG
1	13 00 13	Pompa ausiliaria Dab K 30 HP 0,4 Rinse booster pump Dab K 30 HP 0,4 Pompe rincage Dab K 30 HP 0,4 Nachspülpumpe Dab K 30 HP 0,4 220/50/1 Per tutti i modelli For all the models Tous modeles Für alle Modelle
1	13 00 52	Pompa ausiliaria Dab K 30 HP 0,4 Rinse booster pump Dab K 30 HP 0,4 Pompe rincage Dab K 30 HP 0,4 Nachspülpumpe Dab K 30 HP 0,4 240/50/1 Per tutti i modelli For all the models Tous modeles Für alle Modelle
2	45 60 37	OR K 30 O-ring K 30 Joint thorique K 30 O-Ring Dichtung K 30
3	12 40 15	Girante K 30 Impellor K 30 Turbine K 30 Pumpenflügel K 30
4	14 10 02	Tenuta meccanica K 30 Seal K 30 Presse etoupe K 30 Gleitringdichtung K 30
5	31 40 01	Cuscinetto K 30 Bearing K 30 Roulement K 30 Kugellager K 30
6	33 50 07	Ventola K 30 Fan K 30 Turbine de refroidissement K 30 Flügel K 30
7	31 30 08	Copriventola K 30 Fan protection K 30 Protection turbine K 30 Flügelschutz K 30
8	20 60 01	Condensatore K 30 Condenser K 30 Condensateur K 30 Kondensator K 30
9	46 80 26	Raccordo K 30 Connection K 30 Raccord K 30 Anschluss K 30
10	45 30 02	Raccordo pompa ausiliaria Dab K 30 Rinse booster pump connection Dab K 30 Raccord pompe rincage Dab K 30 Nachspülpumpeanschluss Dab K 30 Mod. S 850 - 870 - 950

Зип Общепит
vsezip.ru

+7(812)987-08-81

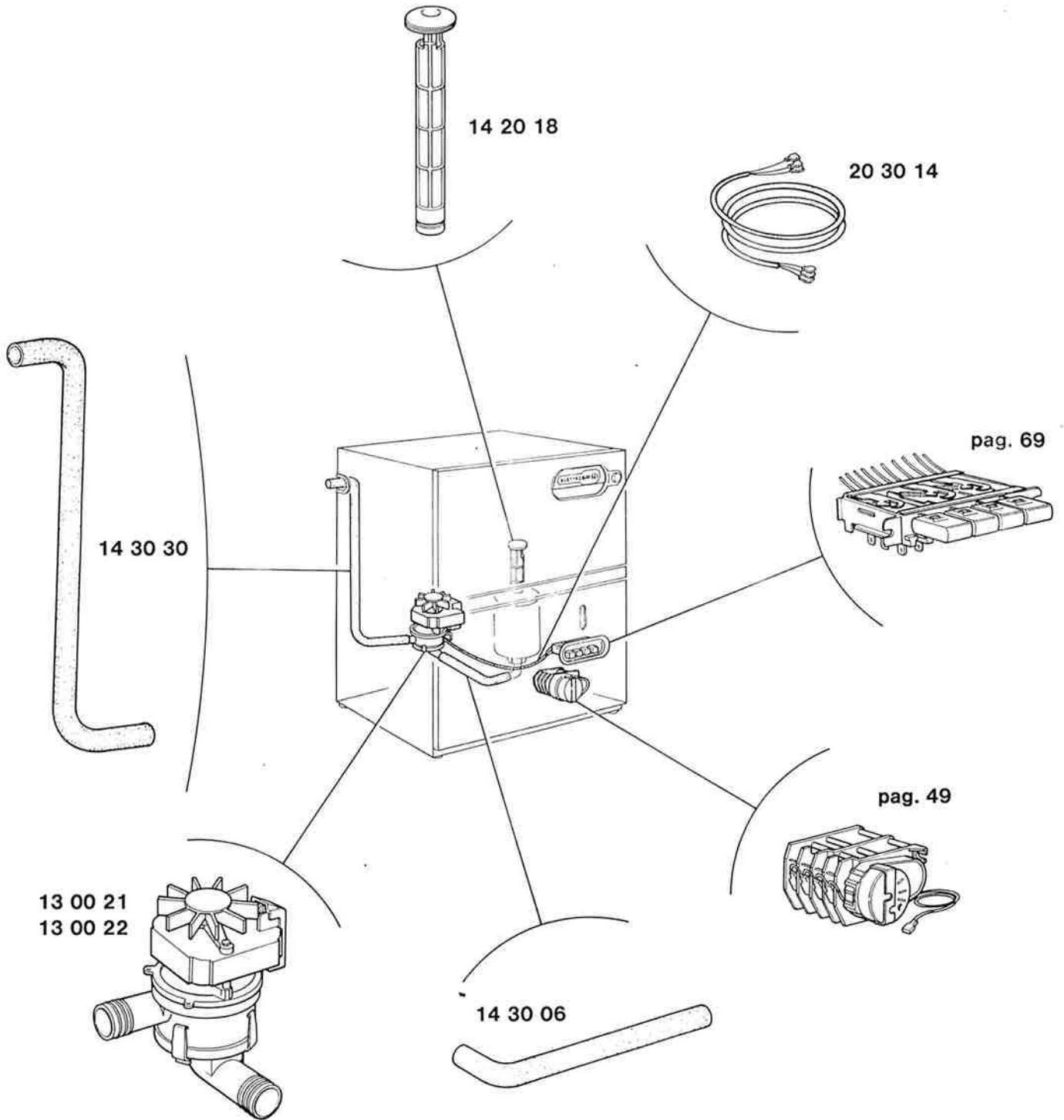

+7(812)987-08-81

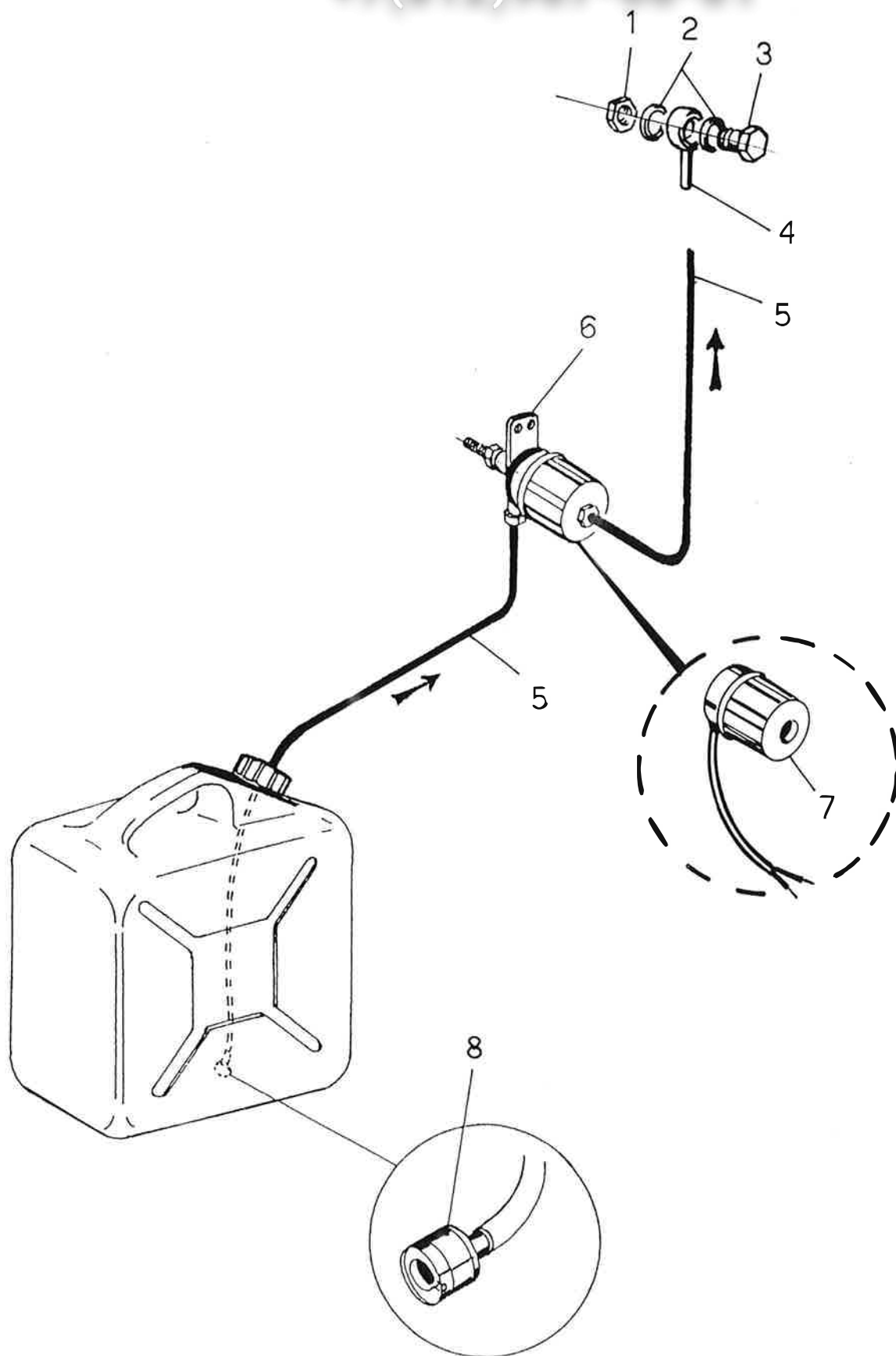



DOSATORE SAPONE
LIQUID DETERGENT DISPENSER
DOSEUR DU PRODUIT DE LAVAGE
SPUELMITTEL-DOSIERGERAET

121

10/87

POS.	CODICE CODE KODE	POS.	CODICE CODE KODE	POS.	CODICE CODE KODE	POS.	CODICE CODE KODE
1	41 70 16						
2	43 70 07						
3	46 80 24						
4	46 80 23						
5	14 30 14						
6	98 70 12						
7	20 10 18						
8	98 60 02						

MODIFICA SPRUZZO LAVAGGIO SUPERIORE
UPPER WASH JET MODIFICATION
MODIFICATION BOUCHON LAVAGE SUPERIEUR
ABAENDERUNG DER OBEREN SPUELDUESE

mod. S:

621 - 623 - 624 - 626

631 - 633 - 634 - 636

160

10/87

Зип-Общестит

vsezip.ru

+7(812)987-08-81

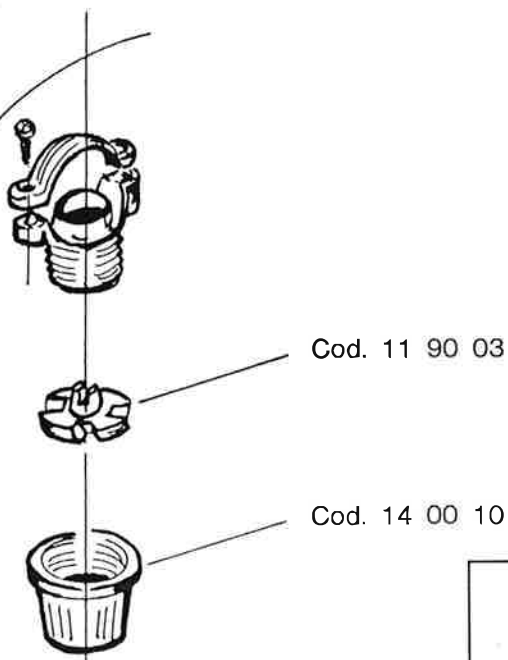
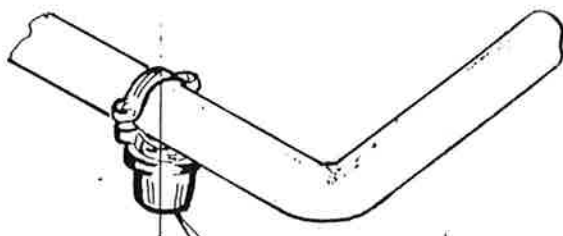
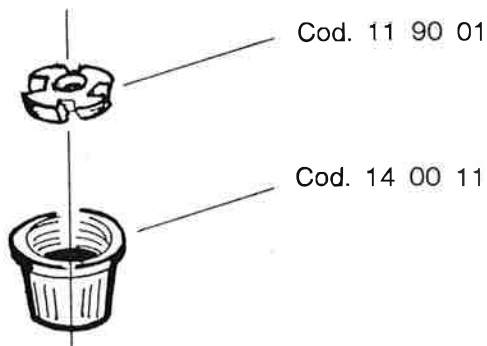
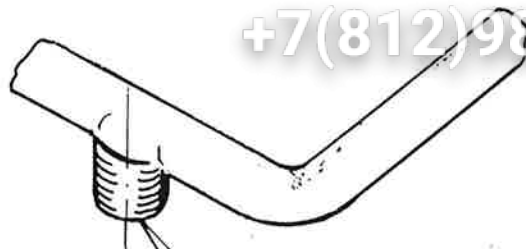

**NUOVO
NEW
NOUVEAU
NEU**

DA MATRICOLA N° 64994
DE MATRICULE NR. 64994
FROM SERIAL NO. 64994
AB MASCHINEN NR. 64994

Wolk

+7(812)987-08-81

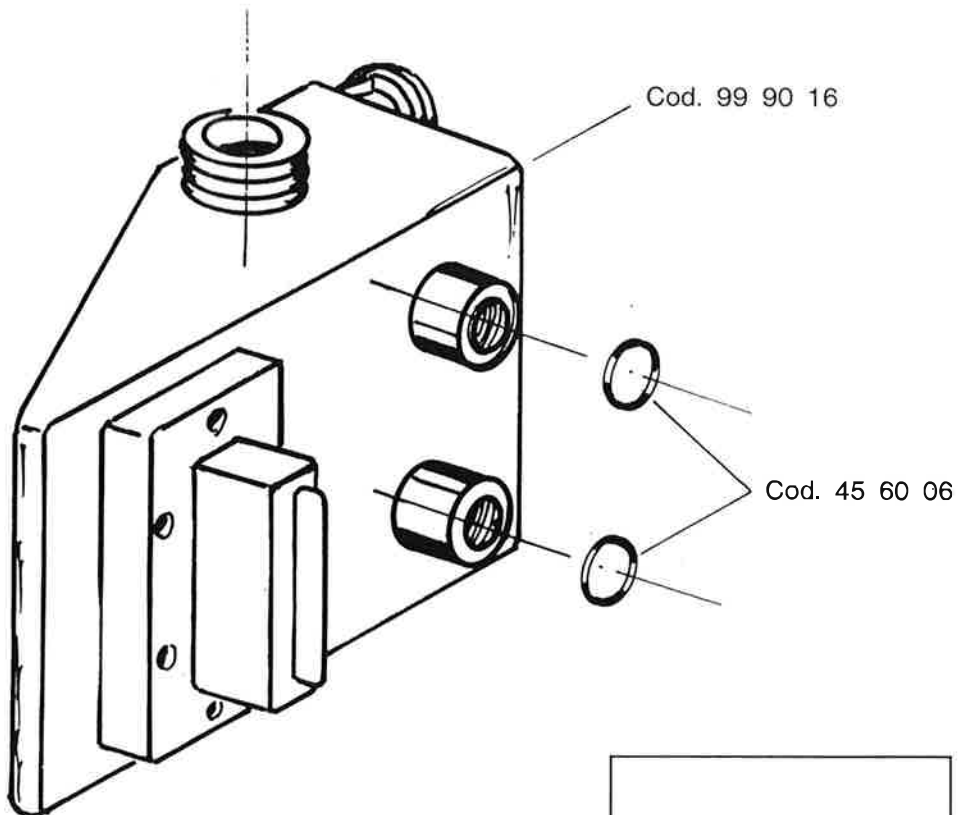
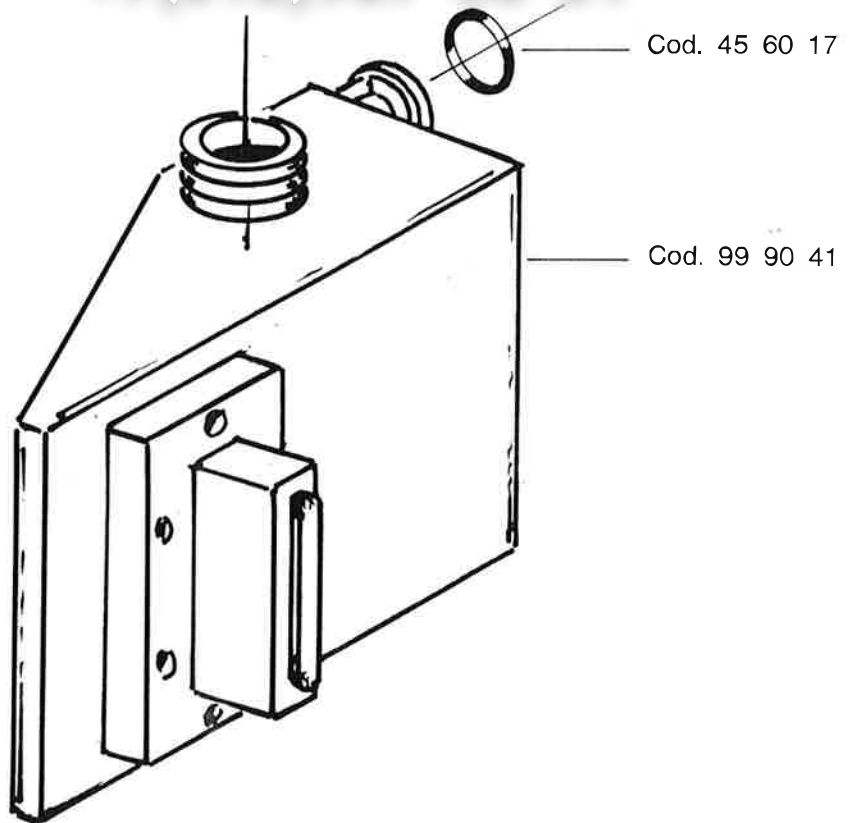

NUOVO
NEW
NOUVEAU
NEU

DA MATRICOLA N° 68473
DE MATRICULE NR. 68473
FROM SERIAL NO. 68473
AB MASCHINEN NR. 68473

E3 wolk

MODIFICA BRACCIO RISCIAQUO SUPERIORE
UPPER RINSE ARM MODIFICATION
MODIFICATION BRAS RINÇAGE SUPERIEUR
OBERER NACHSPÜLARMABÄNDERUNG

mod. S:

621 - 623 - 624 - 626

631 - 633 - 634 - 636

163

10/87

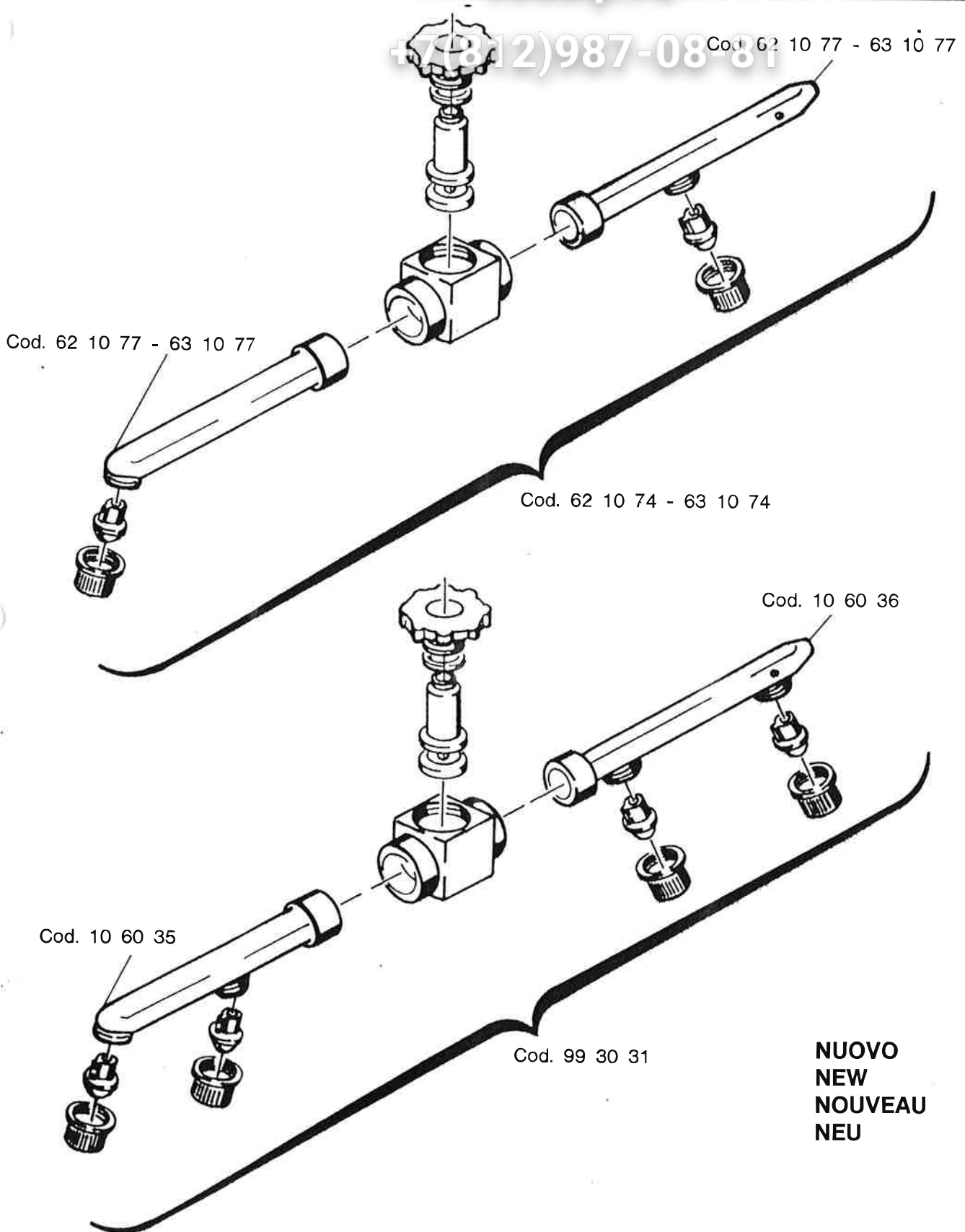

NUOVO
NEW
NOUVEAU
NEU

DA MATRICOLA N° 93700
DE MATRICULE NR. 93700
FROM SERIAL NO. 93700
AB MASCHINEN-NR. 93700

E3 wolk

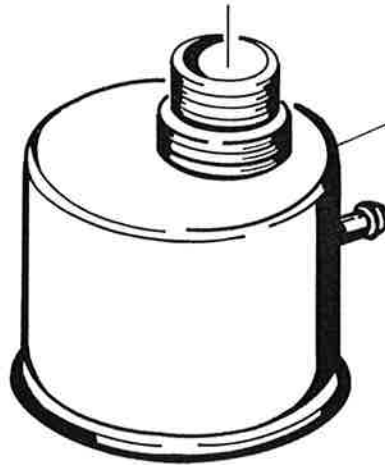
+7(812)987-08-81

Cod. 40 69 99

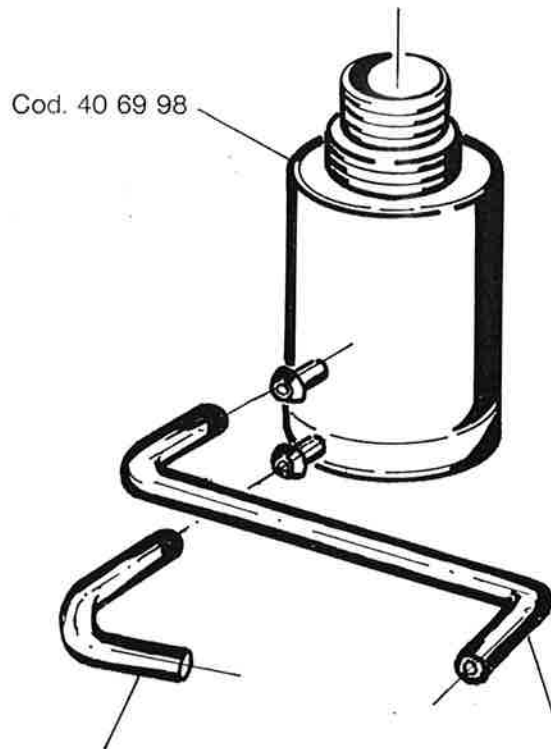

Cod. 40 69 98

Cod. 14 31 05

Cod. 14 31 06

**NUOVO
NEW
NEU
NOUVEAU**DA MATRICOLA N° 92582
FROM SERIAL NO. 92582
AB MASCHINEN NR. 92582
DU MATRICULE NO. 92582

MODIFICA POSIZIONE PRESSOSTATO
MODIFICATION OF PRESSURE SWITCH'S POS.
ÄNDERUNG DER NIVEAUREGLERPOS.
MODIFICATION POSITION PRESSOSTAT

mod. S:
621 - 633 - 624 - 626
631 - 633 - 634 - 636

167

4/88

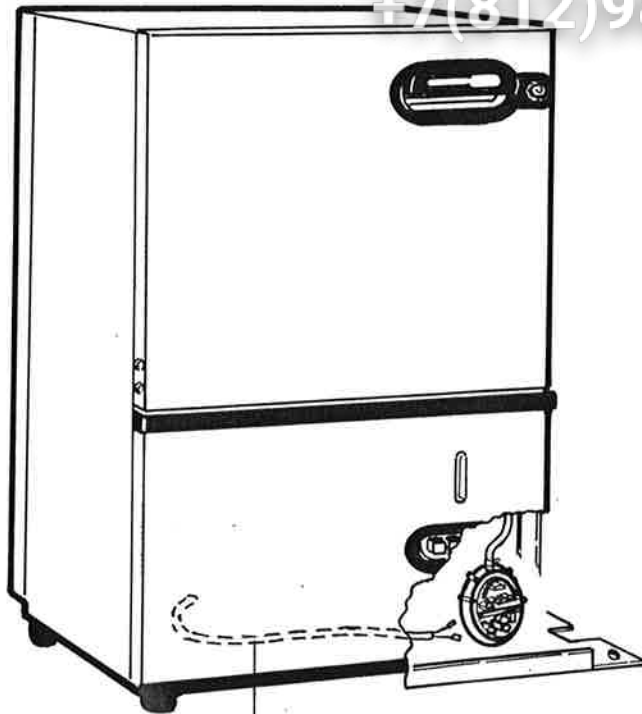

20 30 17 Mod. S: 621 - 624 - 631 - 634

20 30 15 Mod. S: 623 - 626 - 633 - 636

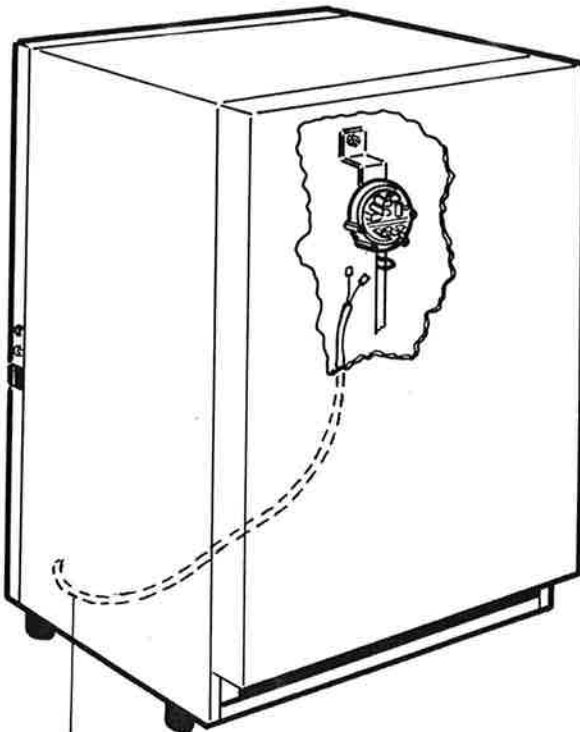

20 30 94 Mod. S: 621 - 624 - 631 - 634

20 30 93 Mod. S: 623 - 626 - 633 - 636

**NUOVO
NEW
NEU
NOUVEAU**

DA MATRICOLA N° 93695
FROM SERIAL NO. 93695
AB MASCHINEN NR. 93695
DU MATRICULE NO. 93695

B wolk

+7(812)987-08-81

Cod. 14 30 16 3/4 Gas mt 1,5
Mod. R 497 - 499 - 501
503 - 505 - 507
S 621 - 623 - 624 - 626
631 - 633 - 634 - 636

Cod. 14 31 12 3/4 Gas mt 1,5
Mod. S 651 - 654 - 810 - 815
830 - 835 - 850 - 870 - 950

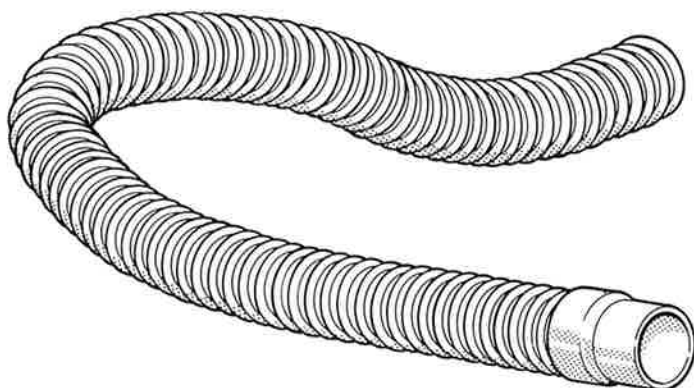

Cod. 14 31 20 Ø 25 mt 1,5
Mod. R 497 - 499 - 501
503 - 505 - 507
S 621 - 623 - 624 - 626
631 - 633 - 634 - 636

Cod. 14 31 21 Ø 38 mt 1,5
Mod. S 651 - 654 - 810 - 815
830 - 835 - 850 - 870 - 950

KIT POMPA SCARICO - POMPA AUSILIARIA

DRAIN PUMP AND BOOSTER PUMP KIT

KIT LAUGENPUMPE UND DRUCKSTEIGERUNGSPUMPE

«KIT» POMPE DE VIDANGE - POMPE DE RINÇAGE

mod. S:

621 - 623 - 624 - 626

631 - 633 - 634 - 636

177

10/90

+7(812)987-08-81

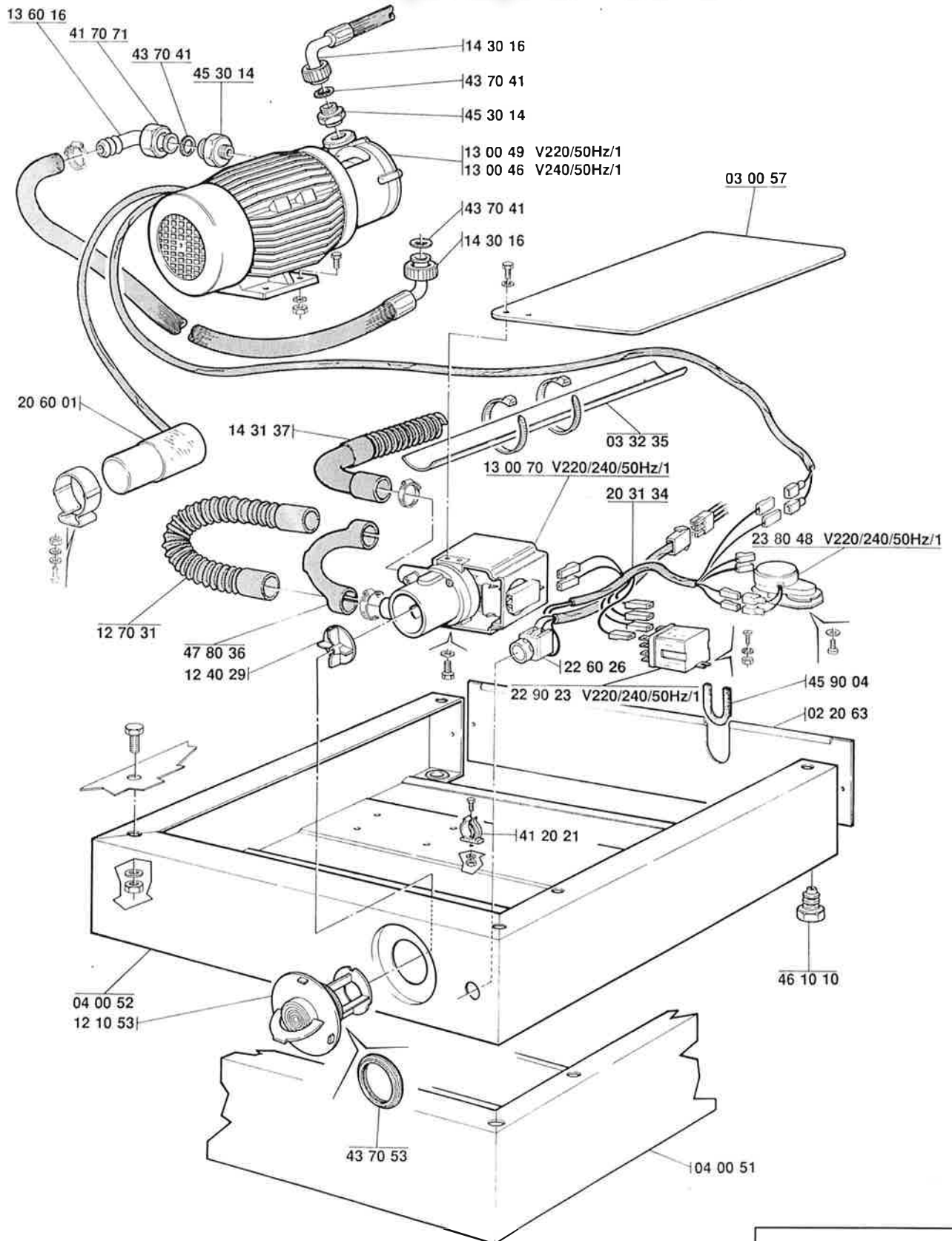

Wolke