

vsezip.ru

+7(812)987-08-81

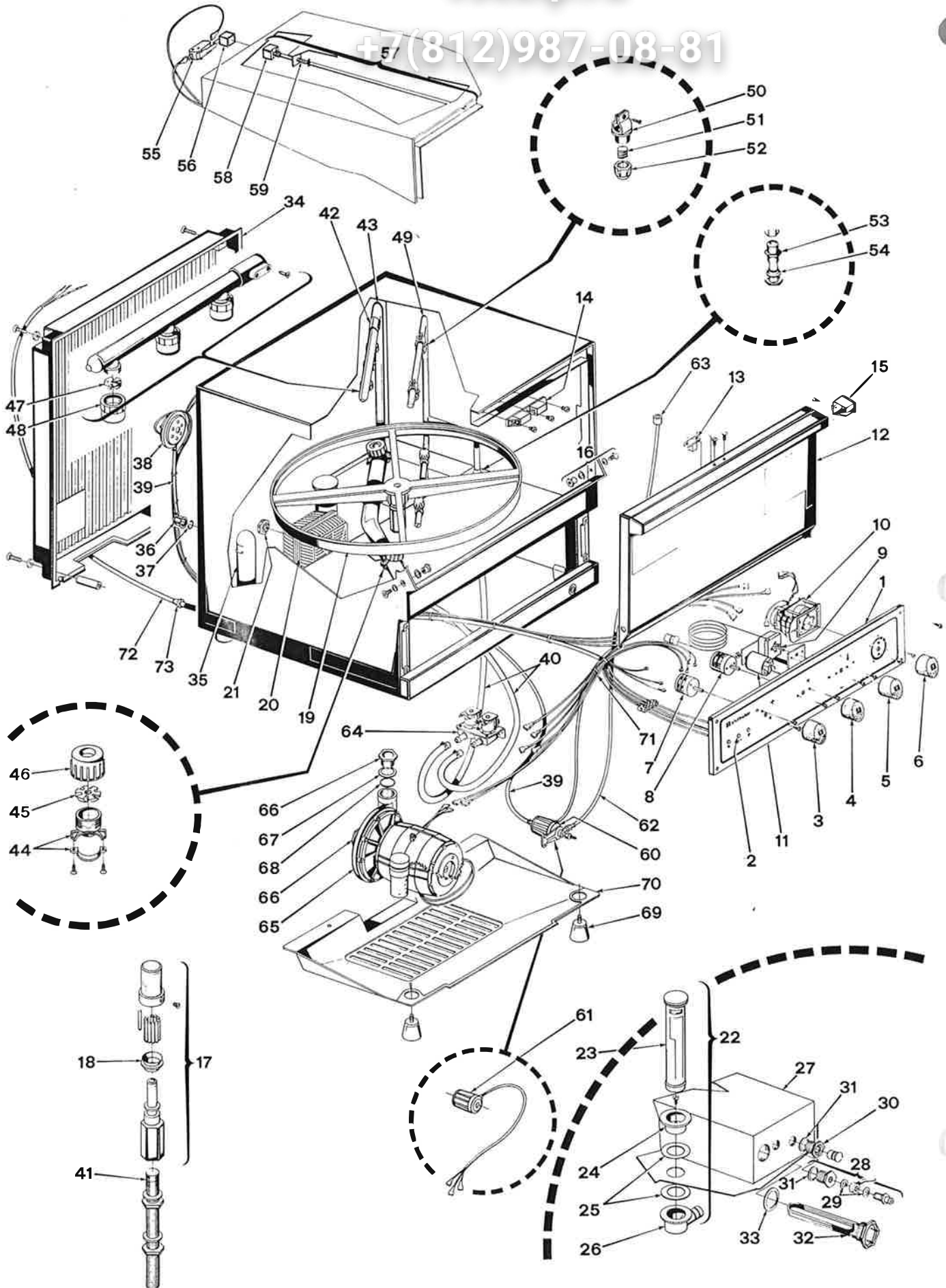

JS.	CODICE CODE KODE	POS.	CODICE CODE KODE	FCS	CODICE CODE KODE	POS.	CODICE CODE KODE
1	02 50 14	33	43 70 28	63	12 10 17		
2	{ 21 60 02	34	45 80 06	64	pag. 93		
	{ 21 60 03	35	98 40 02	65	pag. 98		
3/4	44 70 07	36	46 80 29	66	46 80 06		
5/6	44 70 08	37	{ 45 60 20	67	43 70 27		
7	20 80 03		{ 43 70 19	68	45 60 16		
8	21 30 02	38	22 40 02	69	46 10 02		
9	23 60 08	39	14 30 05	70	46 70 04		
10	pag. 90	40	14 30 04	71	20 30 36		
11	21 20 01	41	99 90 23	72	20 40 17		
12	99 90 28	42	99 90 30	73	45 90 01		
13	12 30 02	43	99 00 15				
14	99 40 01	44	11 00 04				
15	{ 48 00 15	45	11 90 02				
	{ 48 00 16	46	14 00 03				
16	99 90 04	47	11 90 01				
17	32 20 01	48	14 00 02				
18	49 90 18	49	99 30 07				
19	31 90 02	50	11 00 02				
20	12 19 99	51	13 80 01				
21	44 70 26	52	14 00 06				
22	99 90 19	53	99 30 20				
23	14 20 07	54	43 70 30				
24	14 20 01	55	21 80 03				
25	43 70 38	56	99 90 02				
26	46 30 04	57	98 10 03				
27	98 20 02	58	99 90 03				
28	99 10 02	59	44 90 09				
29	43 70 07	60	{ 98 70 01				
30	43 50 01		{ 98 70 05				
31	43 70 31	61	{ 20 10 02				
32	{ 23 00 03		{ 20 10 11				
	{ 23 00 02	62	14 30 13				

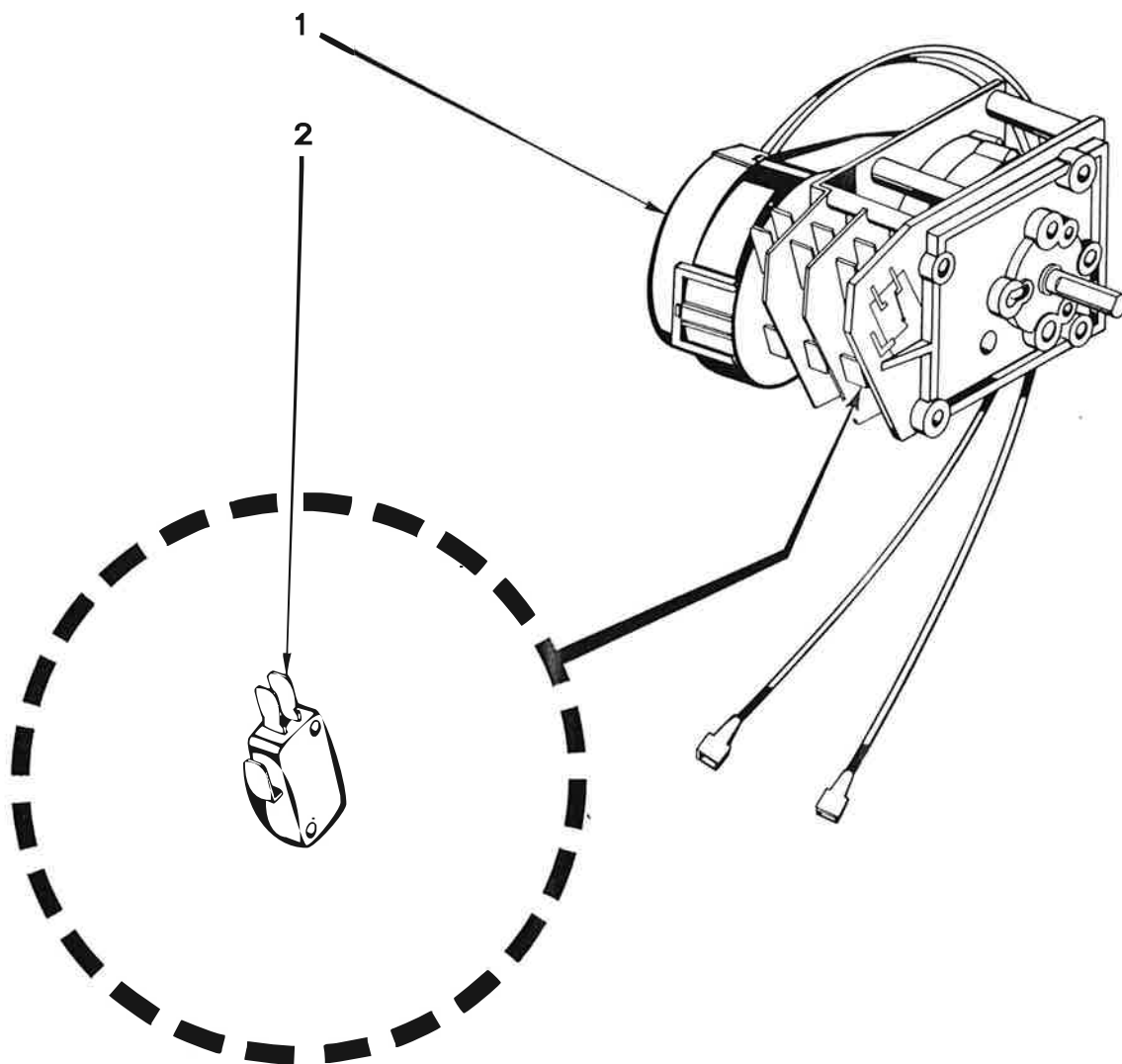

E3 wolk

Timer serie «R» - Timer «R» range

Programmateur serie «R» - Programmschalter Serie «R»

91

10/87

Q.S.	CODICE CODE KODE	DESCRIZIONE - DESCRIPTION - BESCHREIBUNG
1	23 80 25	Timer ciclo 180" - Cronel 2C Cycle timer 180" - Cronel 2C Programmateur cycle 180" - Cronel 2C Programmschalter 180" - Cronel 2C
1	23 80 01	Timer ciclo 180" - Crouzet 3C Cycle timer 180" - Crouzet 3C Programmateur cycle 180" - Crouzet 3C Programmschalter 180" - Crouzet 3C
1	23 80 24	Timer ciclo 180" - Cronel 3C Cycle timer 180" - Cronel 3C Programmateur cycle 180" - Cronel 3C Programmschalter 180" - Cronel 3C
1	23 80 05	Timer ciclo 180" - Cronel 3C Cycle timer 180" - Cronel 3C Programmateur cycle 180" - Cronel 3C Programmschalter 180" - Cronel 3C
1	23 80 16	Timer ciclo 180" - Cronel 3C Cycle timer 180" - Cronel 3C Programmateur cycle 180" - Cronel 3C Programmschalter 180" - Cronel 3C

E3 wolk

Timer serie «R»

Programmateur serie «R»

POS.	CODICE CODE KODE	DESCRIZIONE - DESCRIPTION - BESCHREIBUNG
1	23 80 09	Timer pompa Drain pump timer Programmateur cycle 180" Laugenpumpe
2	21 80 09	Micro timer C Microtimer C Minirupteur p Mikroschalter

Этот документ

vsezip.ru

+7(812)987-08-81

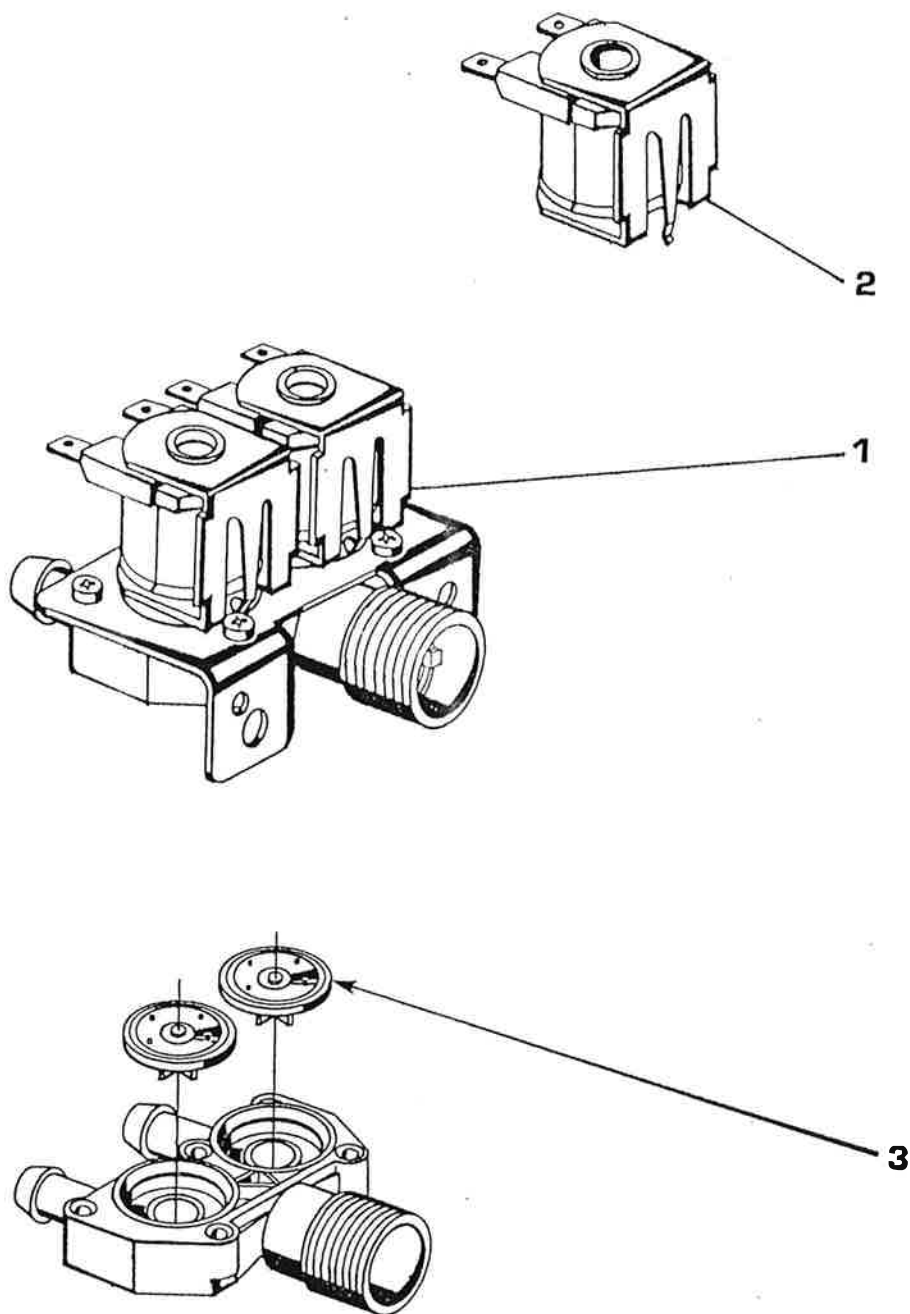
+7(812)987-08-81

POS.	CODICE CODE KODE	DESCRIZIONE - DESCRIPTION - BESCHREIBUNG
1	24 00 06	Valvola - Elbi - 1 via 90° Solenoid valve - Elbi - 1 way 90° Vanne - Elbi - 1 bobine 90° Einweg - Einlassmagnetventil - Elbi - 90° 220-240/50-60/1 Mod. R 495
1	24 00 05	Valvola - Elbi - 1 via 180° Solenoid valve - Elbi - 1 way 180° Vanne - Elbi - 1 bobine 180° Einweg - Einlassmagnetventil - Elbi - 180° 220-240/50-60/1 Mod. R 704 - 706
1	24 00 03	Valvola - 2 vie 180° Solenoid valve - 2 ways 180° Vanne - 2 bobines 180° Zweiweg - Einlassmagnetventil - 180° 220-240/50-60/1 Mod. R 497 - 499 - 501 - 505 - 509 - S 641
1	24 00 02	Valvola - 3 vie 180° Solenoid valve - 3 ways 180° Vanne - 3 bobines 180° Dreiweg - Einlassmagnetventil - 180° 220-240/50-60/1 Mod. R 503 - 507 - 511 - S 643
1	24 00 08	Valvola ottone piccola portata Brass solenoid valve - small capacity Vanne laiton - petite Kleines Einlassmagnetventil aus Messing 220-240/50-60/1 Mod. R 708
1	24 00 07	Valvola ottone grande portata Brass solenoid valve - big capacity Vanne laiton - grande Grosses Einlassmagnetventil aus Messing 220-240/50-60/1 Mod. S 870 fino matricola n° 64902 till serial no. 64902 au matricule n° 64902 bis Maschinen-Nr. 64902

OS.	CODICE CODE KODE	DESCRIZIONE - DESCRIPTION - BESCHREIBUNG
2	20 10 06	Bobina va Coil for so Bobine po Spule für
2	20 10 08	Bobina va Coil for br Bobine va Spule für
2	20 10 07	Bobina va Coil for br Bobine va Spule für
3	29 90 22	Membrana Membrane Membrane Membran

Зин Общепит

vsezip.ru

+7(812)987-08-81

POMPA
WASH PUMP
POMPE
ELEKTROPUMPE

mod. R:
495

Зип Ощепит

96

10/87

vsezip.ru

+7(812)987-08-81

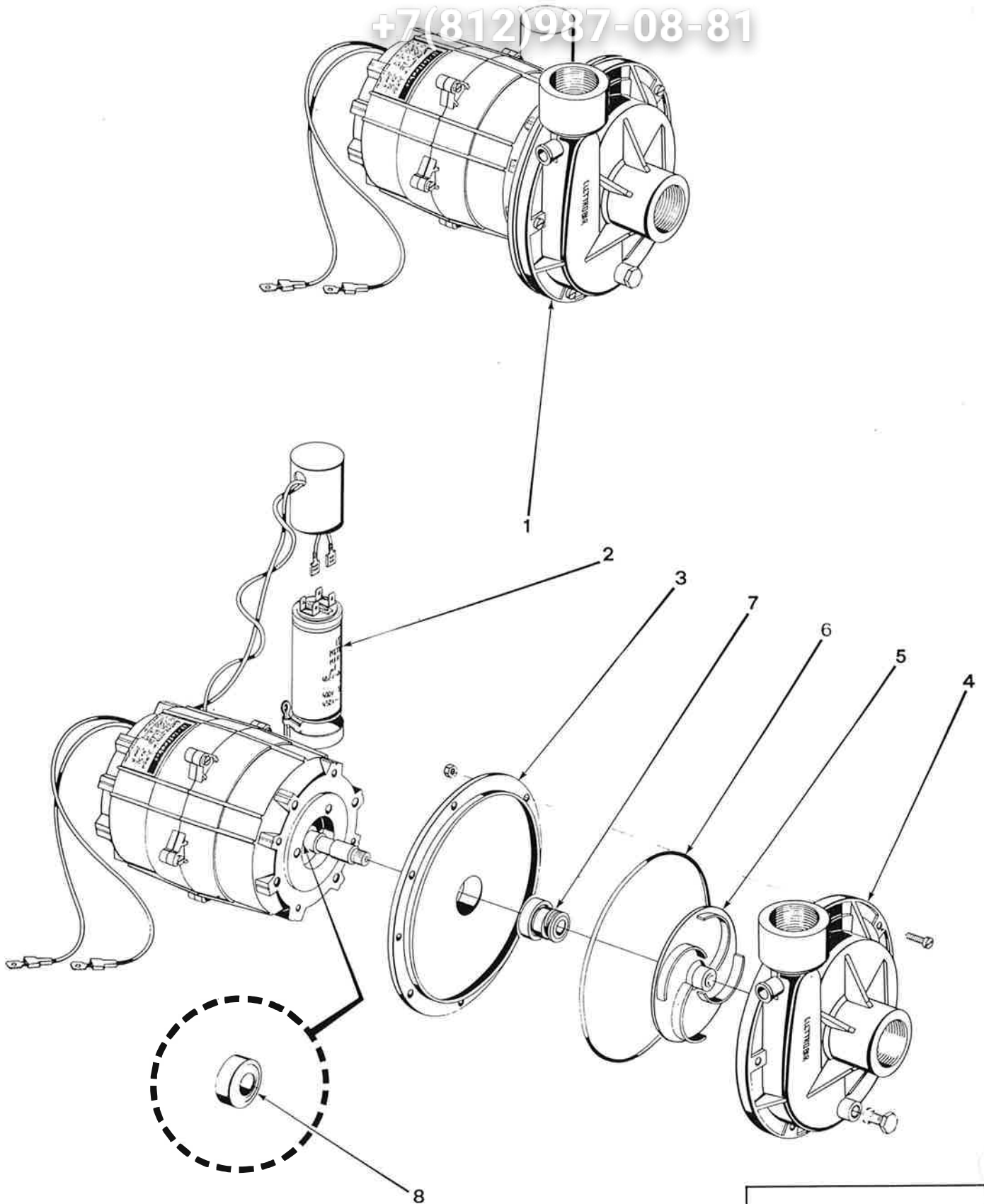

E3 wolk

POMPA
WASH PUMP
POMPE
ELEKTROPUMPE

mod. R:
497 - 499 - 501
503 - 505 - 507

99

Зип Общедит

10/87

POMPA
WASH PUMP
POMPE
ELEKTROPUMPE

mod. R:
497 - 499 - 501
503 - 505 - 507

POS.	CODICE CODE KODE	DESCRIZIONE - DESCRIPTION - BESCHREIBUNG
1	13 00 11	Pompa LC 120 HP 0,5 Wash pump LC 120 HP 0,5 Pompe LC 120 HP 0,5 Elektropumpe LC 120 HP 0,5 220/50/1
1	13 00 12	Pompa LC 120 HP 0,5 Wash pump LC 120 HP 0,5 Pompe LC 120 HP 0,5 Elektropumpe LC 120 HP 0,5 240/50/1
1	13 00 27	Pompa LC 120 HP 0,5 Wash pump LC 120 HP 0,5 Pompe LC 120 HP 0,5 Elektropumpe LC 120 HP 0,5 220/60/1
1	13 00 23	Pompa FIR 1294 HP 0,25 Wash pump FIR 1294 HP 0,25 Pompe FIR 1294 HP 0,25 Elektropumpe FIR 1294 HP 0,25 220/50/1
2	20 60 02	Condensatore LC 120 Condenser LC 120 Condensateur LC 120 Kondensator LC 120
2	20 60 01	Condensatore FIR 1294 Condenser FIR 1294 Condensateur FIR 1294 Kondensator FIR 1294
3	31 50 01	Flangia LC 120 FIR 1294 Flange LC 120 FIR 1294 Flansque LC 120 FIR 1294 Flasch LC 120 - FIR 1294
4	11 60 01	Corpo pompa LC 120 FIR 1294 Flange ext. LC 120 FIR 1294 Flansque ext. LC 120 FIR 1294 Pumpengehäuse LC 120 - FIR 1294
5	12 40 01	Girante LC 120 FIR 1294 50 Hz. Impellor LC 120 FIR 1294 50 Hz. Turbine LC 120 FIR 1294 50 Hz. Pumpenflügel LC 120 FIR 1294 50 Hz.



POS.	CODICE CODE KODE	
5	12 40 20	Girante LC 120 FIR 1294 50 Hz. Impellor LC 120 FIR 1294 50 Hz. Turbine LC 120 FIR 1294 50 Hz. Pumpenflügel LC 120 FIR 1294 50 Hz.
6	45 60 24	OR LC 120 FIR 1294 O-ring LC 120 FIR 1294 Joint thor LC 120 FIR 1294 O-Ring D 120 FIR 1294
7	14 10 02	Tenuta m LC 120 FIR 1294 Seal LC 120 FIR 1294 Presse e LC 120 FIR 1294 Gleitring LC 120 FIR 1294
7	14 10 01	Tenuta m LC 120 FIR 1294 Seal LC 120 FIR 1294 Presse e LC 120 FIR 1294 Gleitring LC 120 FIR 1294
8	31 40 02	Cuscinet LC 120 FIR 1294 Bearing LC 120 FIR 1294 Roulement LC 120 FIR 1294 Kugellag LC 120 FIR 1294
8	31 40 01	Cuscinet LC 120 FIR 1294 Bearing LC 120 FIR 1294 Roulement LC 120 FIR 1294 Kugellag LC 120 FIR 1294

+7(812)987-08-81

vsezip.ru

+7(812)987-08-81

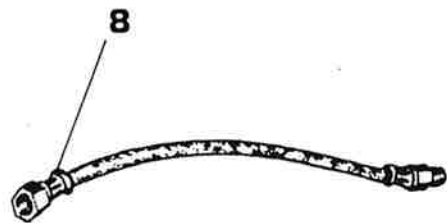
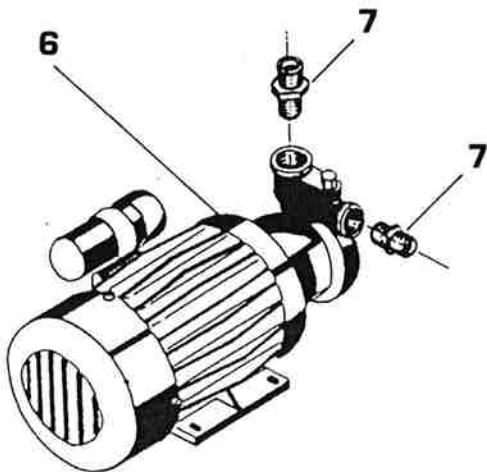
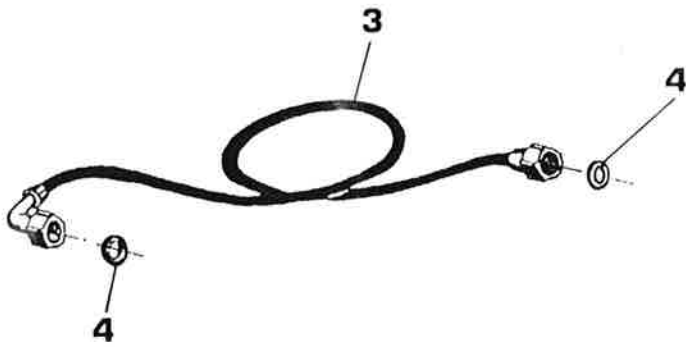
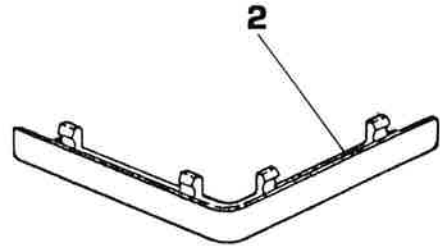

POS.	CODICE CODE KODE	DESCRIZIONE - DESCRIPTION - BESCHREIBUNG	POS.	CODICE CODE KODE	
1	70 20 02	Anello cesto ø 33 Rack ring ø 33 Volant panier ø 33 Körbring ø 33	5	14 30 19 *	Tubo scarico Drain pipe ø 22 Tuyau vidange Ablaufschlauch
1	70 20 01	Anello cesto ø 38 Rack ring ø 38 Volant panier ø 38 Körbring ø 38	5	14 30 20 *	Tubo scarico Drain pipe ø 38 Tuyau vidange Ablaufschlauch
2	46 10 03	Piedino cesto grigio Grey rack feet Pied panier gris Grauer Korbfuss	6	pag. 115	Pompa ausilia Rinse booster Pompe de rinç Nachspülpump
3	14 30 16 *	Tubo carico con curva 3/4 gas Inlet pipe with bend 3/4 gas Tuyau alimentation avec courbe 3/4 gaz Zulaufschlauch mit Kurve 3/4 Gas	7	46 80 26	Raccordo pom Rinse booster Raccord pomp Nachspülpump
3	14 30 18 *	Tubo carico 19 x 26 Inlet pipe 19 x 26 Tuyau alimentation 19 x 26 Zulaufschlauch 19 x 26	8	14 30 21	Tubo flessibile Rinse booster Tuyau flexible Nachspülpump
4	43 70 41	Guarnizione carico 3/4 gas Inlet gasket 3/4 gas Joint alimentation 3/4 gaz Zulaufdichtung 3/4 Gas			
5	14 30 17	Tubo scarico Mt. 1,5 ø 22 Drain pipe mt. 1,5 ø 22 Tuyau vidange mt. 1,5 ø 22 Ablaufschlauch Mt. 1,5 ø 22			Modelli con pompa scarico Models with drain pump Modèles avec tuyau vidange Modelle mit Laugenpumpe

Этот Общепит

0/87

vsezip.ru

+7(812)987-08-81

Всё Общедоступно
vsezip.ru

+7(812)987-08-81

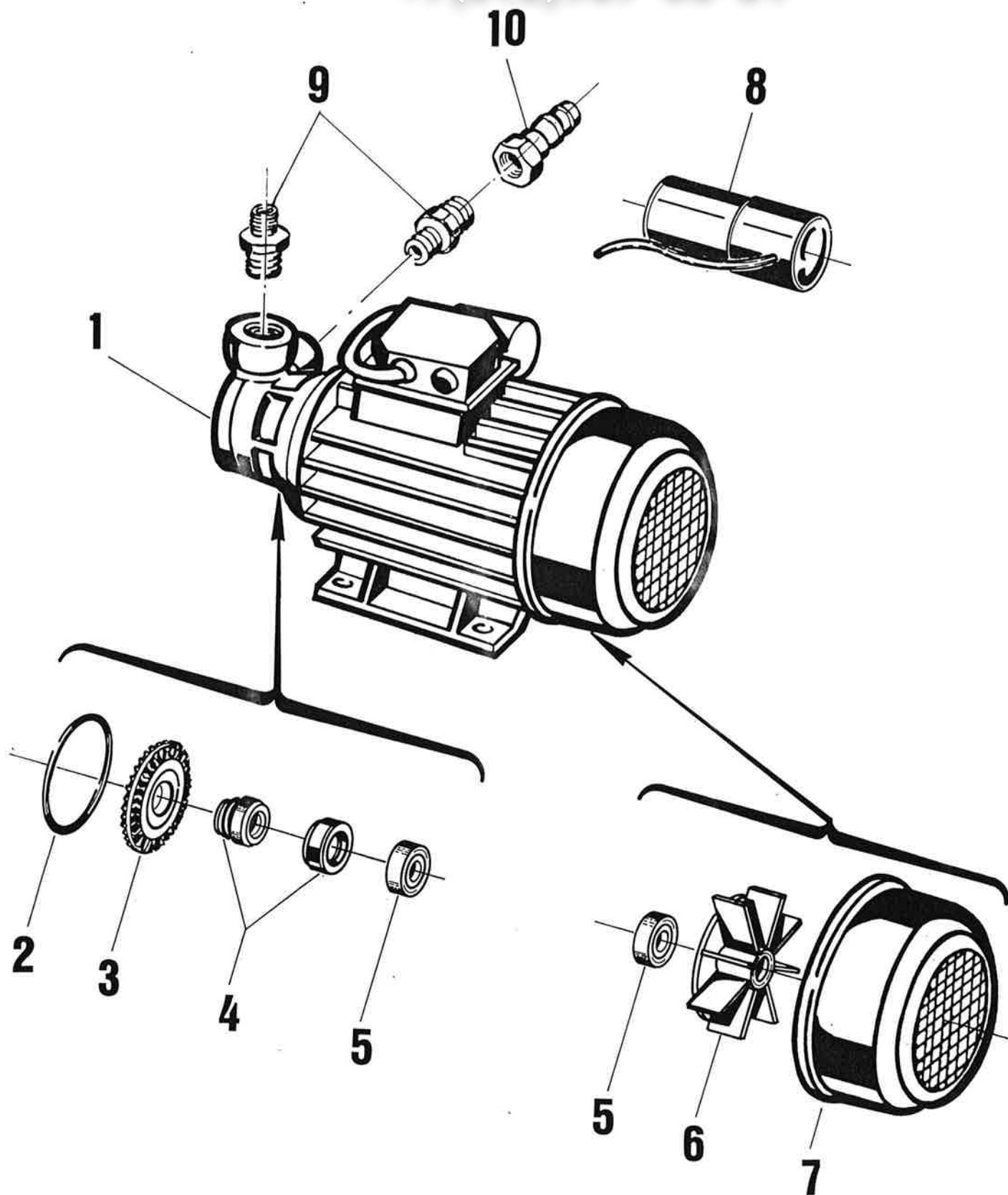

DESCRIZIONE - DESCRIPTION - BESCHREIBUNG

+7(812)987-08-81

POS.	CODICE CODE KODE	DESCRIZIONE - DESCRIPTION - BESCHREIBUNG
1	13 00 13	Pompa ausiliaria Dab K 30 HP 0,4 Rinse booster pump Dab K 30 HP 0,4 Pompe rincage Dab K 30 HP 0,4 Nachspülpumpe Dab K 30 HP 0,4 220/50/1 Per tutti i modelli For all the models Tous modeles Für alle Modelle
1	13 00 52	Pompa ausiliaria Dab K 30 HP 0,4 Rinse booster pump Dab K 30 HP 0,4 Pompe rincage Dab K 30 HP 0,4 Nachspülpumpe Dab K 30 HP 0,4 240/50/1 Per tutti i modelli For all the models Tous modeles Für alle Modelle
2	45 60 37	OR K 30 O-ring K 30 Joint thorique K 30 O-Ring Dichtung K 30
3	12 40 15	Girante K 30 Impellor K 30 Turbine K 30 Pumpenflügel K 30
4	14 10 02	Tenuta meccanica K 30 Seal K 30 Presse etoupe K 30 Gleitringdichtung K 30
5	31 40 01	Cuscinetto K 30 Bearing K 30 Roulement K 30 Kugellager K 30
6	33 50 07	Ventola K 30 Fan K 30 Turbine de refroidissement K 30 Flügel K 30
7	31 30 08	Copriventola K 30 Fan protection K 30 Protection turbine K 30 Flügelschutz K 30
8	20 60 01	Condensatore K 30 Condenser K 30 Condensateur K 30 Kondensator K 30
9	46 80 26	Raccordo K 30 Connection K 30 Raccord K 30 Anschluss K 30
10	45 30 02	Raccordo pompa ausiliaria Dab K 30 Rinse booster pump connection Dab K 30 Raccord pompe rincage Dab K 30 Nachspülpumpeanschluss Dab K 30 Mod. S 850 - 870 - 950

+7(812)987-08-81

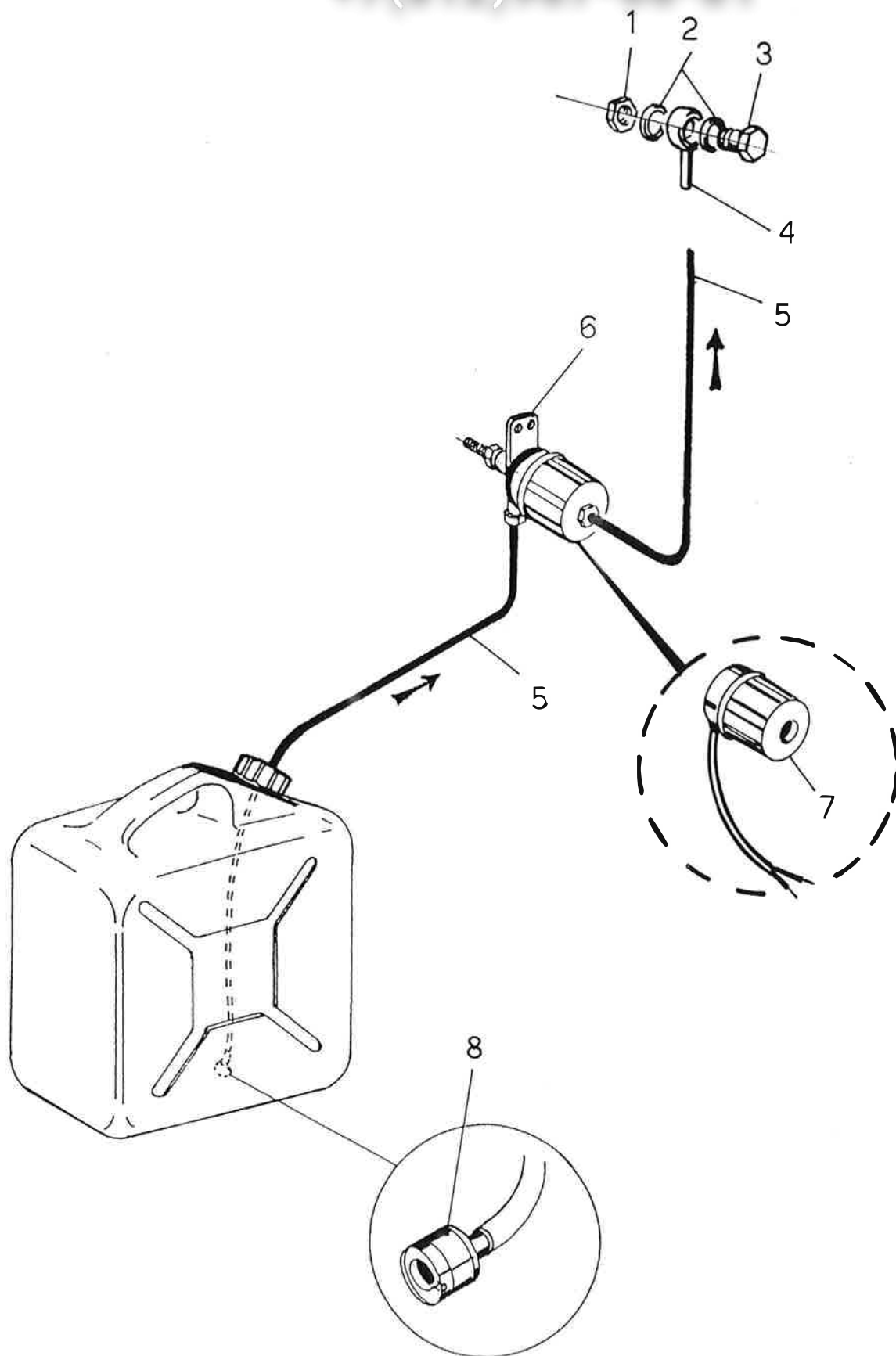



DOSATORE SAPONE
LIQUID DETERGENT DISPENSER
DOSEUR DU PRODUIT DE LAVAGE
SPUELMITTEL-DOSIERGERAET

121

10/87

POS.	CODICE CODE KODE	POS.	CODICE CODE KODE	POS.	CODICE CODE KODE	POS.	CODICE CODE KODE
1	41 70 16						
2	43 70 07						
3	46 80 24						
4	46 80 23						
5	14 30 14						
6	98 70 12						
7	20 10 18						
8	98 60 02						

+7(812)987-08-81

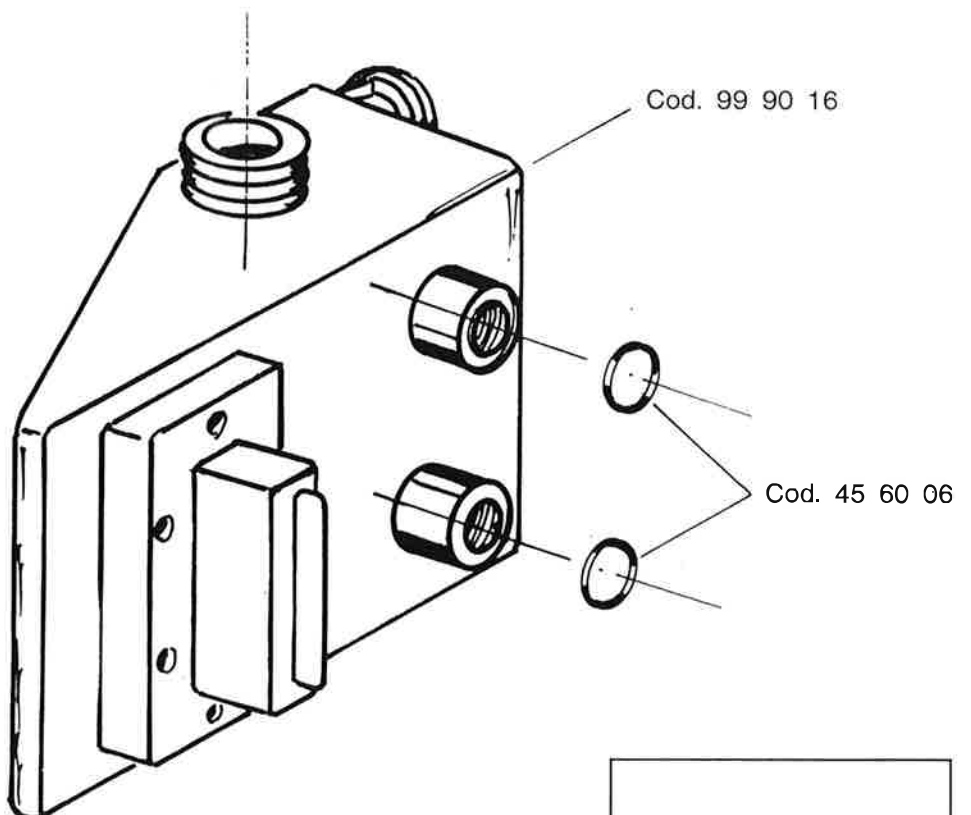
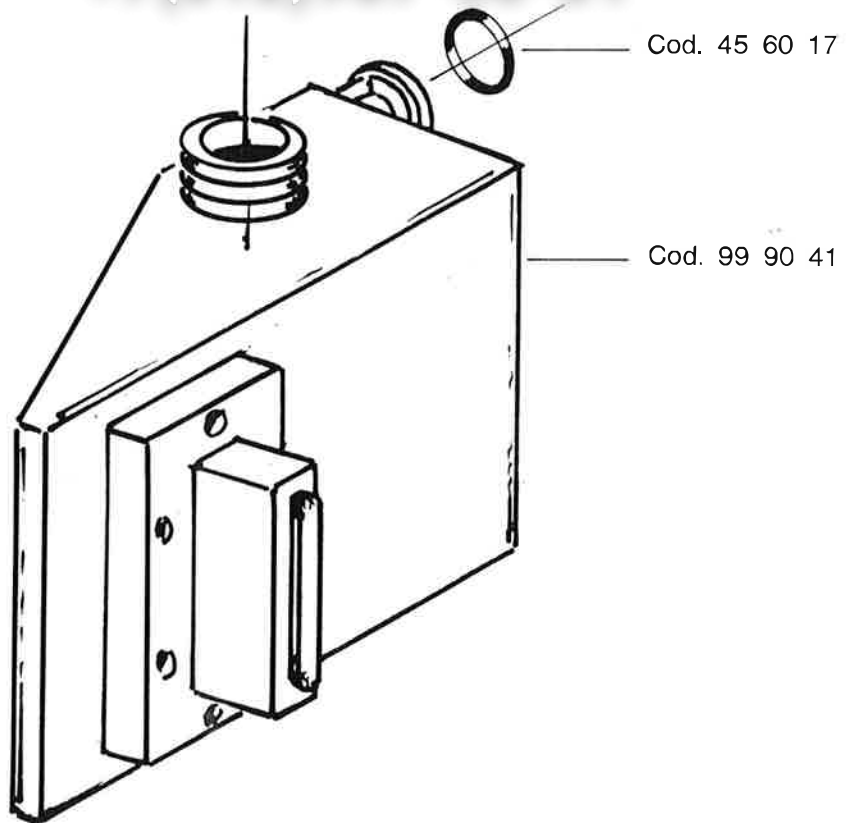

NUOVO
NEW
NOUVEAU
NEU

DA MATRICOLA N° 68473
DE MATRICULE NR. 68473
FROM SERIAL NO. 68473
AB MASCHINEN NR. 68473

E3 wolk

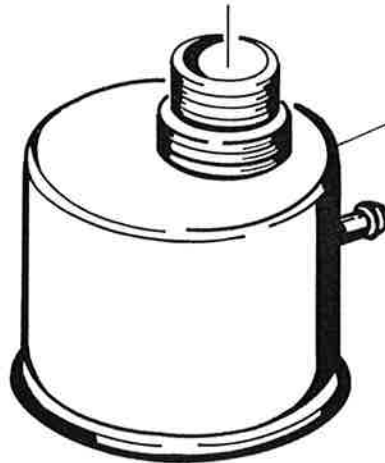
+7(812)987-08-81

Cod. 40 69 99

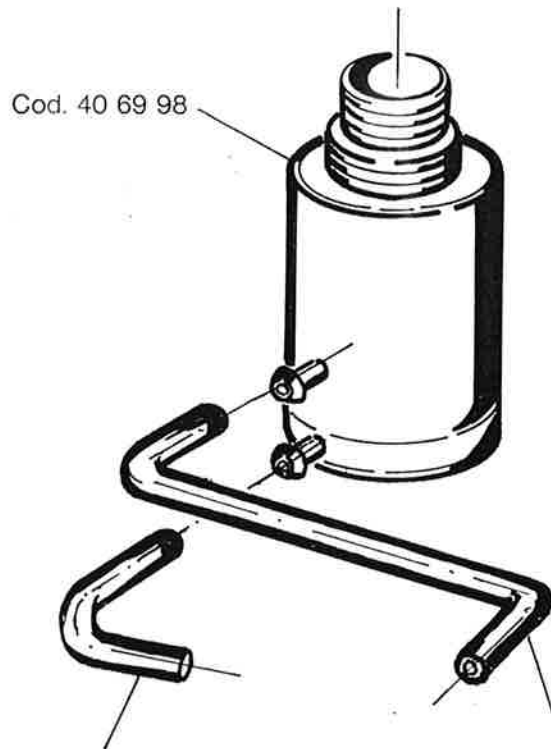

Cod. 40 69 98

Cod. 14 31 05

Cod. 14 31 06

**NUOVO
NEW
NEU
NOUVEAU**DA MATRICOLA N° 92582
FROM SERIAL NO. 92582
AB MASCHINEN NR. 92582
DU MATRICULE NO. 92582

+7(812)987-08-81

Cod. 14 30 16 3/4 Gas mt 1,5
Mod. R 497 - 499 - 501
503 - 505 - 507
S 621 - 623 - 624 - 626
631 - 633 - 634 - 636

Cod. 14 31 12 3/4 Gas mt 1,5
Mod. S 651 - 654 - 810 - 815
830 - 835 - 850 - 870 - 950

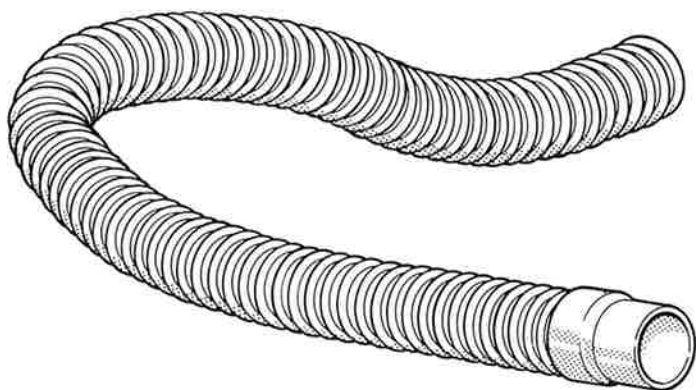

Cod. 14 31 20 Ø 25 mt 1,5
Mod. R 497 - 499 - 501
503 - 505 - 507
S 621 - 623 - 624 - 626
631 - 633 - 634 - 636

Cod. 14 31 21 Ø 38 mt 1,5
Mod. S 651 - 654 - 810 - 815
830 - 835 - 850 - 870 - 950