

Зип Общепит

vsezip.ru

+7(812)987-08-81

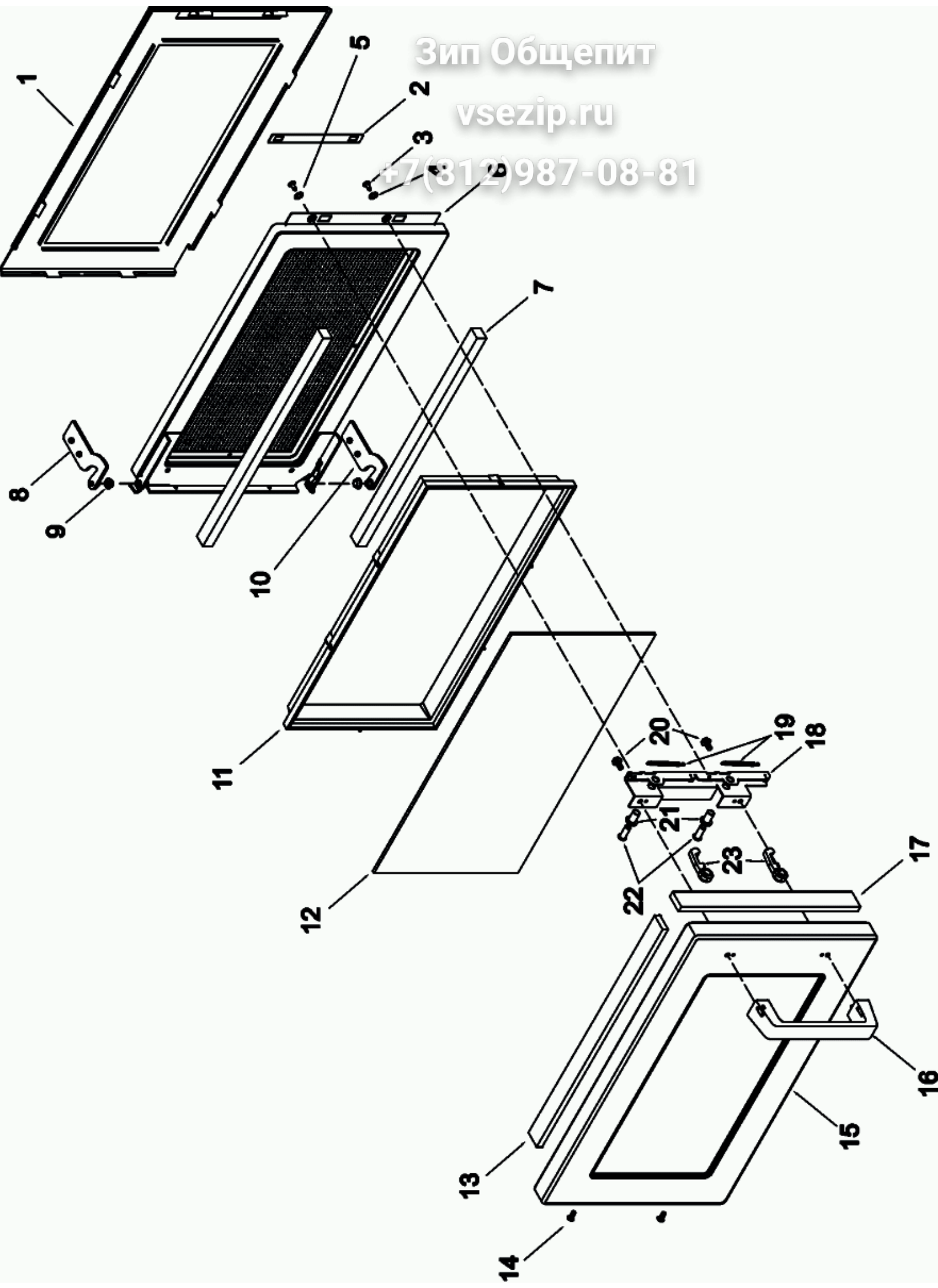

Зип Общепит

vsezip.ru

(812)987-08-81

Used on models prior  
to serial number 0902100848

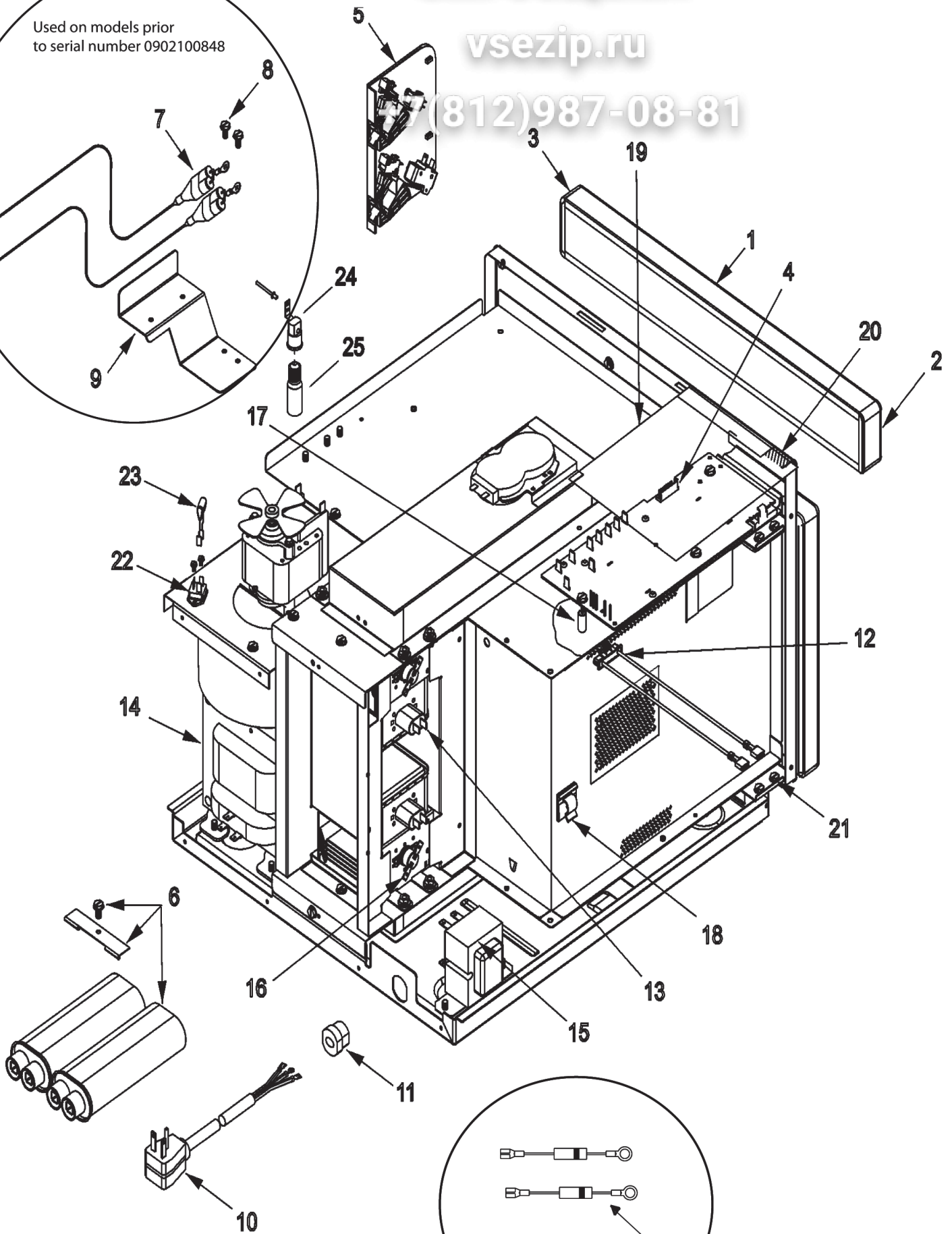
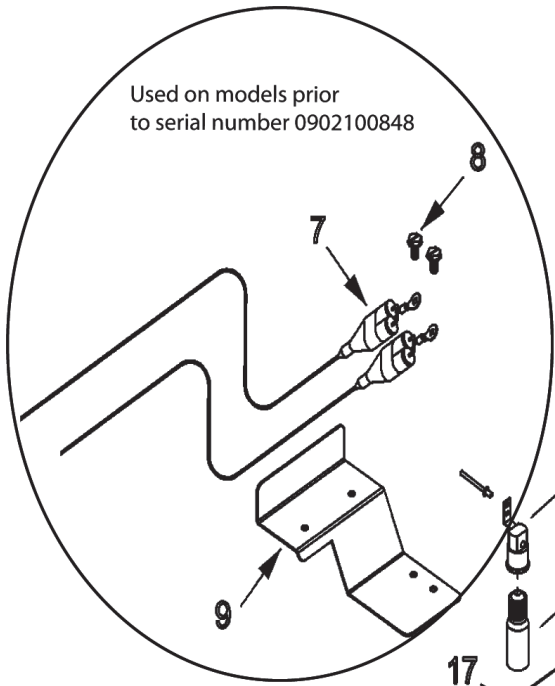

Used on models starting  
at serial number 0902100848

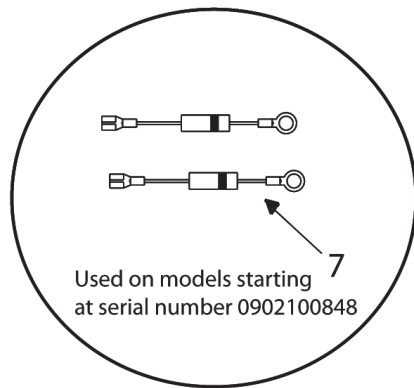

Зип Общепит

vsezip.ru

+7(812)987-08-81

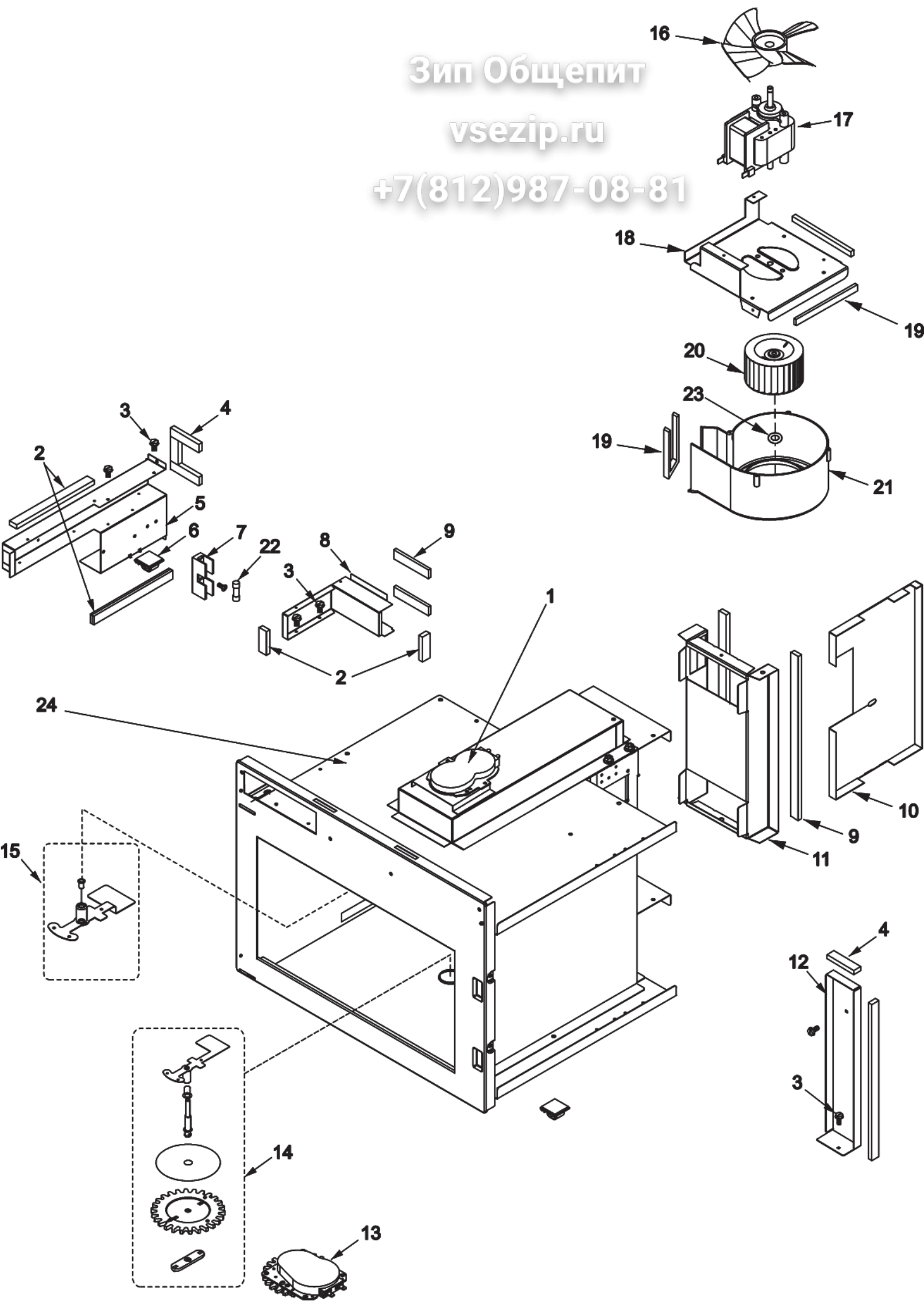

Зип Ощепит

vsezip.ru

+7(812)987-08-81

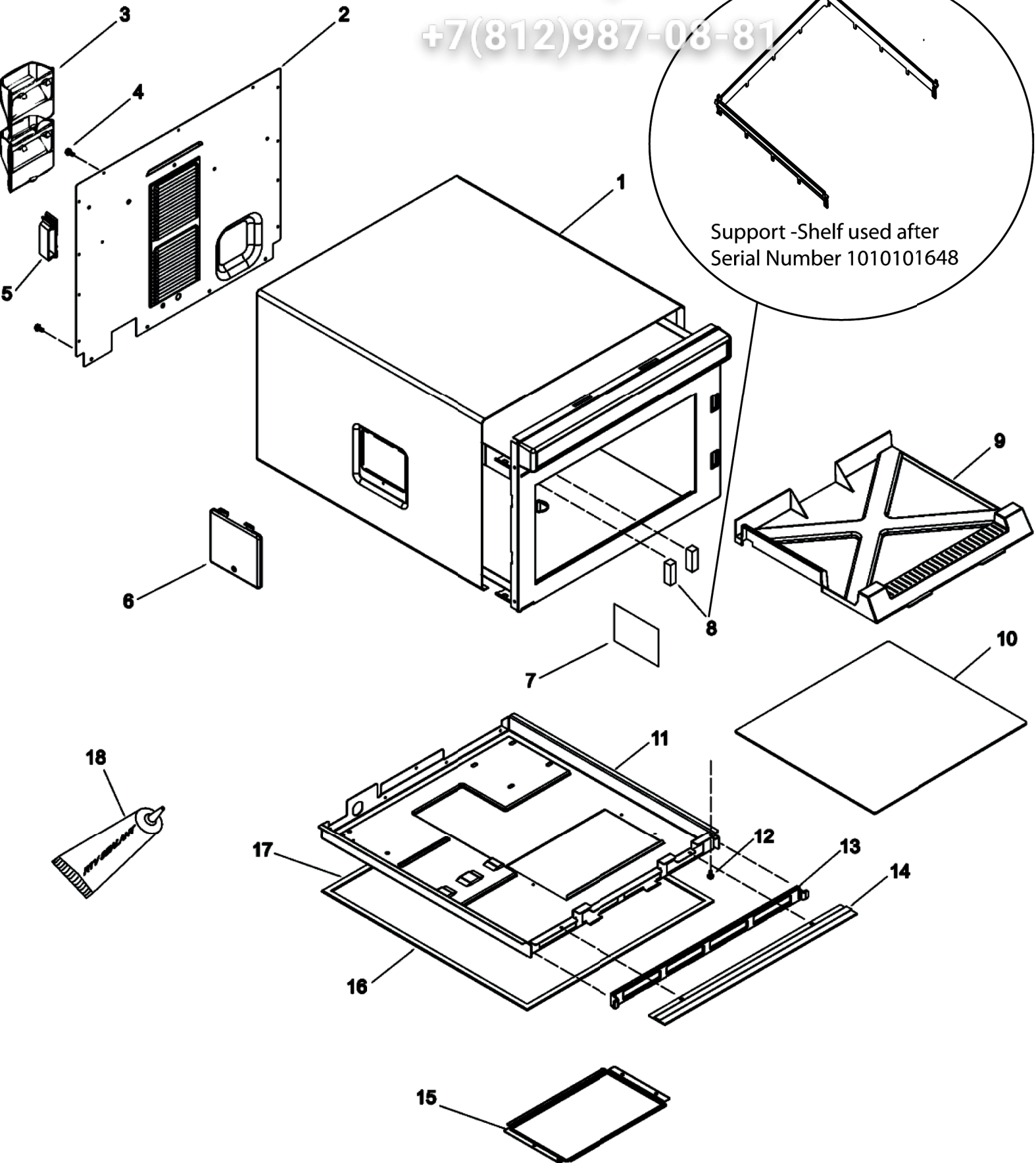

Seite	Pos	Kredtor Artikel Nr.	GB
001	001	R0150148	INNER DOOR ASSY
001	002	12526201	LINKAGE-DOOR LATCH
001	003	M0230815	SCREW
001	004	M0274066	WASHER-NYLON
001	005	M0272503	WASHER, #6 LOCK
001	006	12472202	DOOR RING WELD-E CT
001	007	10966601	GASKET-NEOPRENE
001	008	12126805	TOP HINGE PLATE WELD
001	009	5210001001	WASHER-NYLON SHOULDER
001	010	12126806	BOTTOM HINGE PLATE WELD
001	011	R0150147	RETAINER, LENS
001	012	12133804	WINDOW, OUTER
001	013	12210804	ABSORBER-ENERGY
001	014	M0230518	SCREW, TC
001	015	R9900567	DOOR, OUTER
001	016	12133901	HANDLE-DOOR
001	017	12210803	ABSORBER-ENERGY
001	018	12114401	BRKT-DOOR LATCH WSH
001	019	C8893502	SPRING-DOOR LATCH
001	020	12992307	SCREW-TF/HEX RoHS
001	021	M0800501	SPACER
001	022	12127001	PIN, LATCH
001	023	12126901	LATCH-DOOR
002	001	R9900111	TOUCH PANEL ASSY
002	001	M0216517	SCREW
002	002	12131001	ENDCAP-ESC RIGHT
002	003	12131002	ENDCAP-ESC LEFT
002	004	M0227333	SCREW, TC
002	004	R0131389	KIT, HV/LV BOARD
002	005	M0237906	SCREW- HI-LO
002	005	12538901Q	SWITCH, INTERLOCK ASSY
002	006	59001160	CAPACITOR- .69
002	006	M0216515	SCREW
002	006	12132501	STRAP-CAPACITOR
002	007	R9800022	KIT, DIODE
002	008	12991101	SCREW-SM/KNIFE RoHS
002	009	12529501	BRKT-DIODE
002	009	M0216515	SCREW
002	010	59001672	POWER CORD
002	011	M0370003	RELIEF-STRAIN
002	012	M0234422	SCREW
002	012	59001667	THERMAL CUTOUT
002	013	D7831007	MAGNETRON-2M229K
002	014	M0251028	SCREW, T.C.
002	014	12136107	TRANSFORMER, HV
002	016	B5684121	THERMAL CUTOUT
002	016	M0229916	SCREW-TC
002	017	M0308801	CAP-SCREW
002	018	M0104106	CLIP-CORD
002	019	12160602	SHIELD-SPILL
002	020	M0275163	TAPE-TRANSFER (ROLL)
002	021	M0253540	SCREW, TC
002	022	R0157373	KIT, TRIAC
002	022	M0216515	SCREW
002	023	10172901Q	SNUBBER ASSY
002	024	R9900584	KIT, RECEPTACLE
002	025	A3073101	LAMP-25W
003	001	R0150186	KIT, ANTENNA MOTOR

003	002	M0275058	TAPE-FOAM (ROLL)
003	003	M0216515	SCREW
003	004	A3030302	GASKET
003	006	M0104106	CLIP-CORD
003	007	M0216515	SCREW
003	007	10091101	BLOCK-FUSE
003	008	12135704	DUCT, CAVITY EXHAUST
003	009	10966607	GASKET-NEOPRENE
003	010	12134101	DIVIDER, FLOW
003	011	R0150161	DUCT ASSY
003	012	12525701	BARRIER-AIR
003	013	R9900667	KIT, ANTENNA MOTOR- BOTTOM
003	014	R9900585	KIT, ANTENNA- BOTTOM
003	015	R0150185	KIT, ANTENNA- TOP
003	016	B5706704	BLADE, FAN
003	017	12138102	MOTOR, BLOWER
003	018	12271103	BRKT-BLOWER WSH
003	019	59002162	GASKET, PER FT
003	020	12138201	WHEEL, BLOWER
003	021	12138302	SCROLL, BLOWER
003	022	M0805201	FUSE-25A
003	023	M0118901	CLIP
003	024	12002682	KIT, CAVITY- HDC12A
004	001	12408501	WRAPPER-OC
004	002	12296804	ACCESS PANEL-E CT
004	004	M0216703	SCREW
004	005	M0118705	NLA- CLIP-GUIDE
004	006	M0274072	NLA- SPACER-RUBBER
004	006	10785608	COVER-LIGHT
004	006	M0249632	SCREW, T F
004	007	R9900114	KIT, WINDOW
004	008	12496801	SUPPORT-SHELF
004	009	12126601	ANTENNA SHIELD
004	010	R0150144	KIT, CERAMIC TRAY W/SEALER
004	011	R0000036	BASE PAN ASSY
004	012	12991101	SCREW-SM/KNIFE RoHS
004	013	59001659	FILTER, AIR
004	014	M0210816	NLA- SCREW, SM
004	014	12131301	TRIM
004	015	12486002	BASE COVER-E CT
004	015	M0216515	SCREW
004	016	59001643	GASKET, BASEPAN- CUT
004	017	59001642	GASKET, BASEPAN- CUT
004	018	M0275598	SEALER
		RT2240005	TECH SHEET-COMM'L MICRO **NO
		59001689	HARNESS, WIRE
		59001661	HARNESS, HV
		12485601	HARNESS, LW ANTENNA
		12155701	LABEL-MENU

120V 60HZ  
3-WIRE

SCHEMATIC  
CONDITION:  
DOOR OPEN

INTERLOCK SWITCH  
SCHEMATIC

DOOR CLOSED

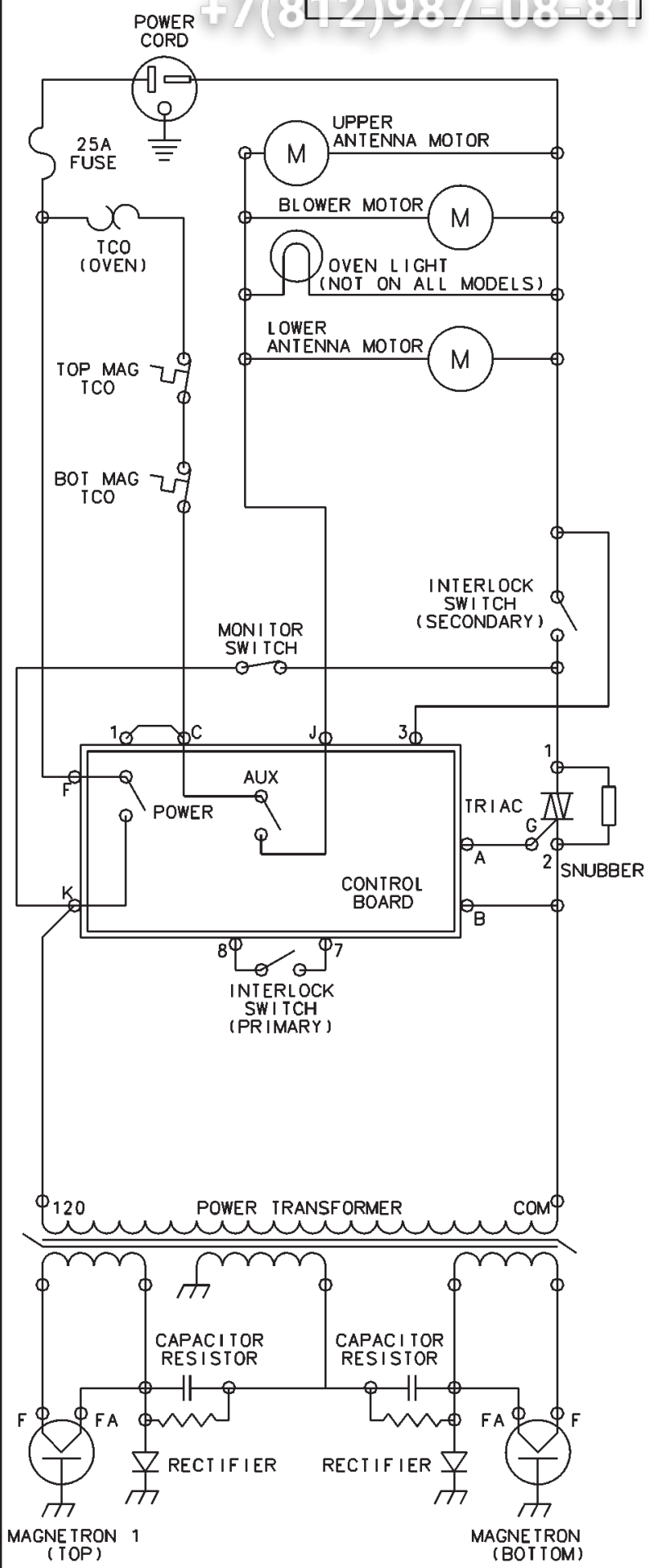

Зип ОбщениТ

www.zip.ru

+7(812)987-08-81