

Зип Общепит

НОВАРТ

vsezip.ru

+7(812)987-08-81

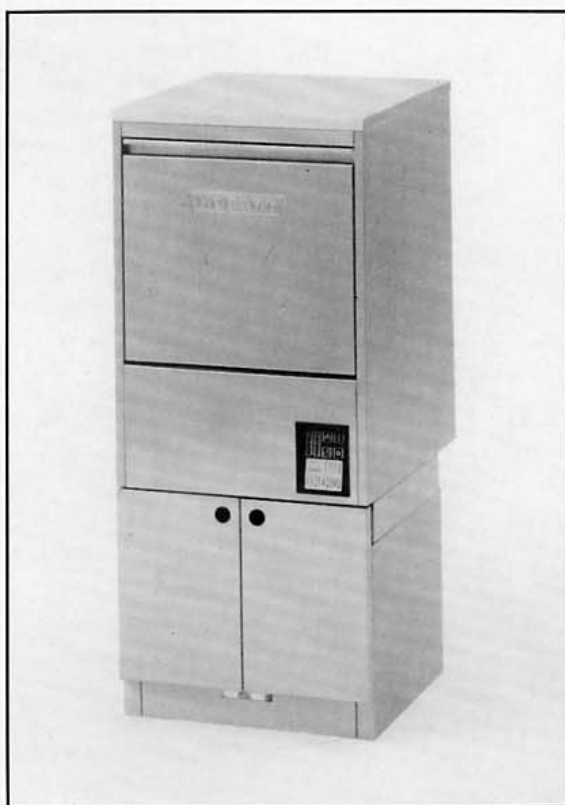

UW-55

Spare Parts
Pièces Détachées
Ersatzteile
Onderdelen

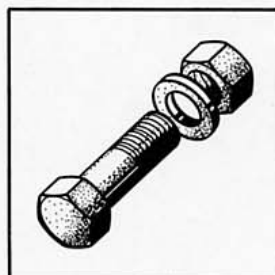

Зип Ощепит

vsezip.ru

+7(812)987-08-81

Contents

Tank and panels	3
Door	4
Water inlet	5
Anti-siphon-device	6
Rinse booster heater	7
Wash pump	8
Wash and rinse system	9
Drain and strainers	10
Drain pump	11
Rinse booster pump	12
Control box	13
Transformer	14
Detergent dispenser	15
Rinse agent dispenser	16/17
Extension for 900 mm height	18
Supporting frame	19

Sommaire

Bac et panneaux	3
Porte	4
Arrivée d'eau	5
Brise-vide	6
Chaudière	7
Pompe de lavage	8
Système de lavage et de rinçage	9
Vidange et filtres	10
Pompe de vidange	11
Pompe élévatrice de pression	12
Coffret électrique	13
Transformateur	14
Doseur de produit détergent	15
Doseur de produit lessiviel	16/17
Socle pour 900 mm hauteur	18
Bâti inférieur	19

Inhalt

Tank und Verkleidungen	3
Tür	4
Eingangsleitung	5
Rücksaugeverhinderer	6
Durchlauferhitzer	7
Waschpumpe	8
Wasch- und Spülsystem	9
Ablauf und Siebe	10
Ablaufpumpe	11
Drucksteigerungspumpe	12
Schaltkasten	13
Transformator	14
Reiniger-Dosiergerät	15
Klarspülmittel-Dosiergerät	16/17
Sockel für 900 mm Höhe	18
Untergestell	19

Inhoud

Tank en panelen	3
Deur	4
Water toevoer	5
Vacuumbreker	6
Booster	7
Waspomp	8
Was en spoelsysteem	9
Afvoer en zeven	10
Afvoerpomp	11
Spoelpomp	12
Schakelkast	13
Transformator	14
Wasmiddel-doseerapparaat	15
Spoelmiddel-doseerapparaat	16/17
Uitbreiding voor 900 mm hoogte	18
Onderstel	19

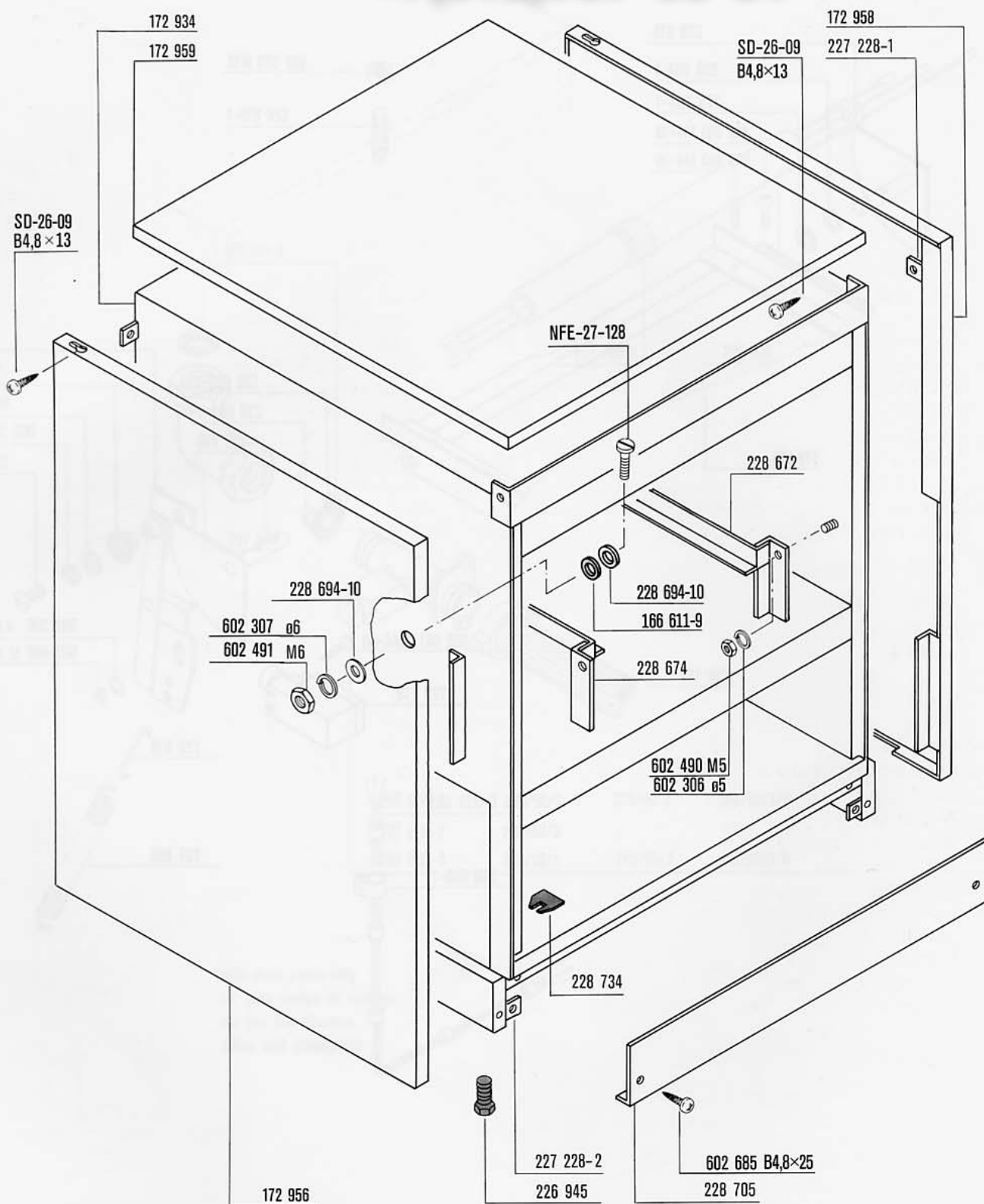

vsezip.ru

+7(812)987-08-81

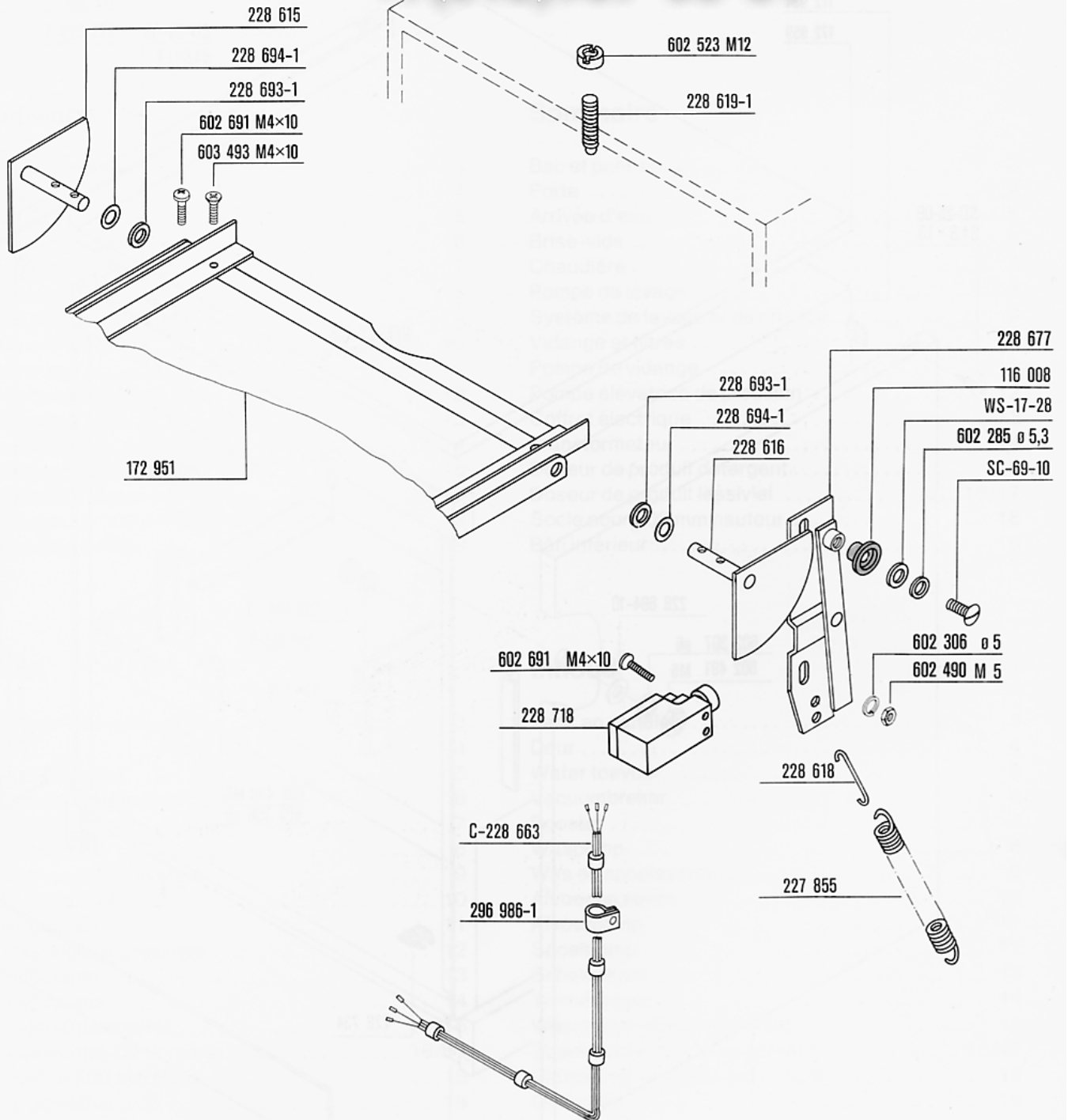

vsezip.ru

+7(812)987-08-81

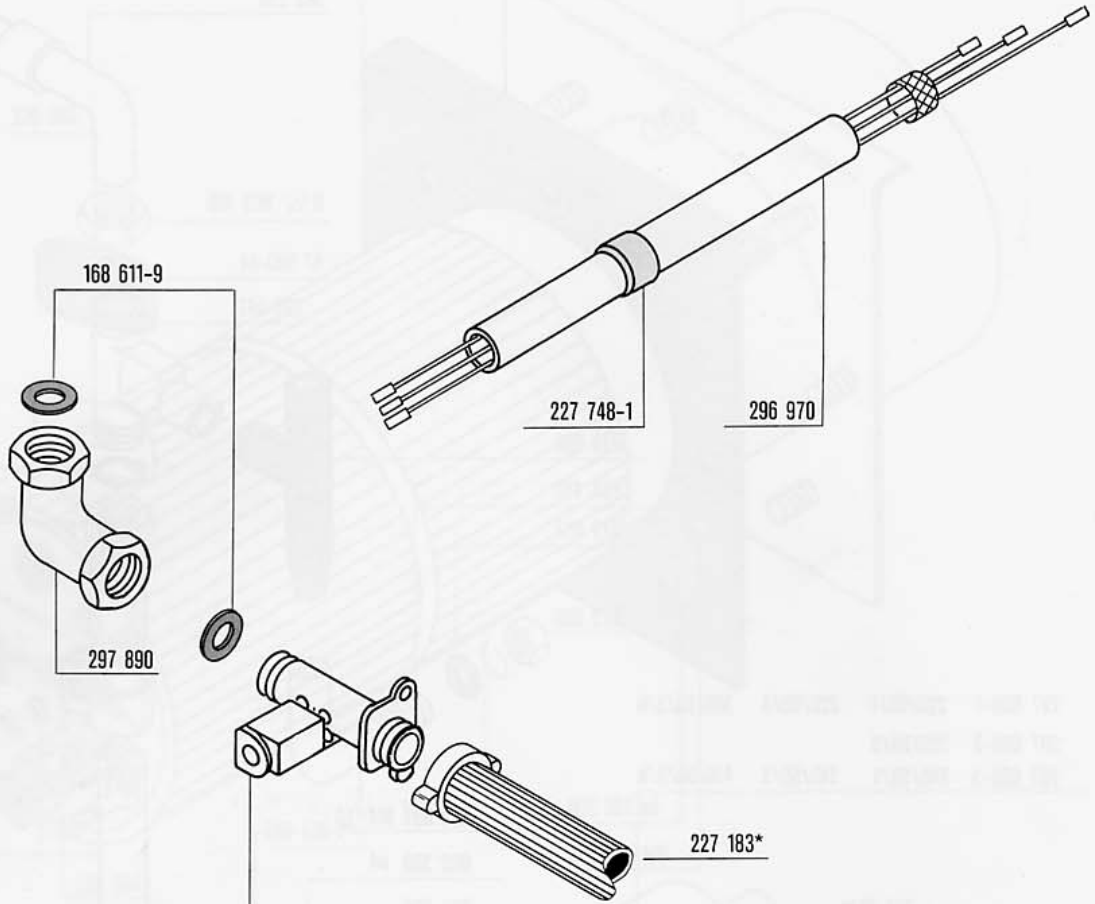

297 808-1	220/50/1	220/50/3	380/50/3/N
297 808-2	220/60/3		
297 808-3	240/50/1	240/50/3	415/50/3/N

*with drain pump only
 slt. avec pompe de vidange
 nur bei Ablaufpumpe
 alleen met afvoerpomp

vsezip.ru

+7(812)987-08-81

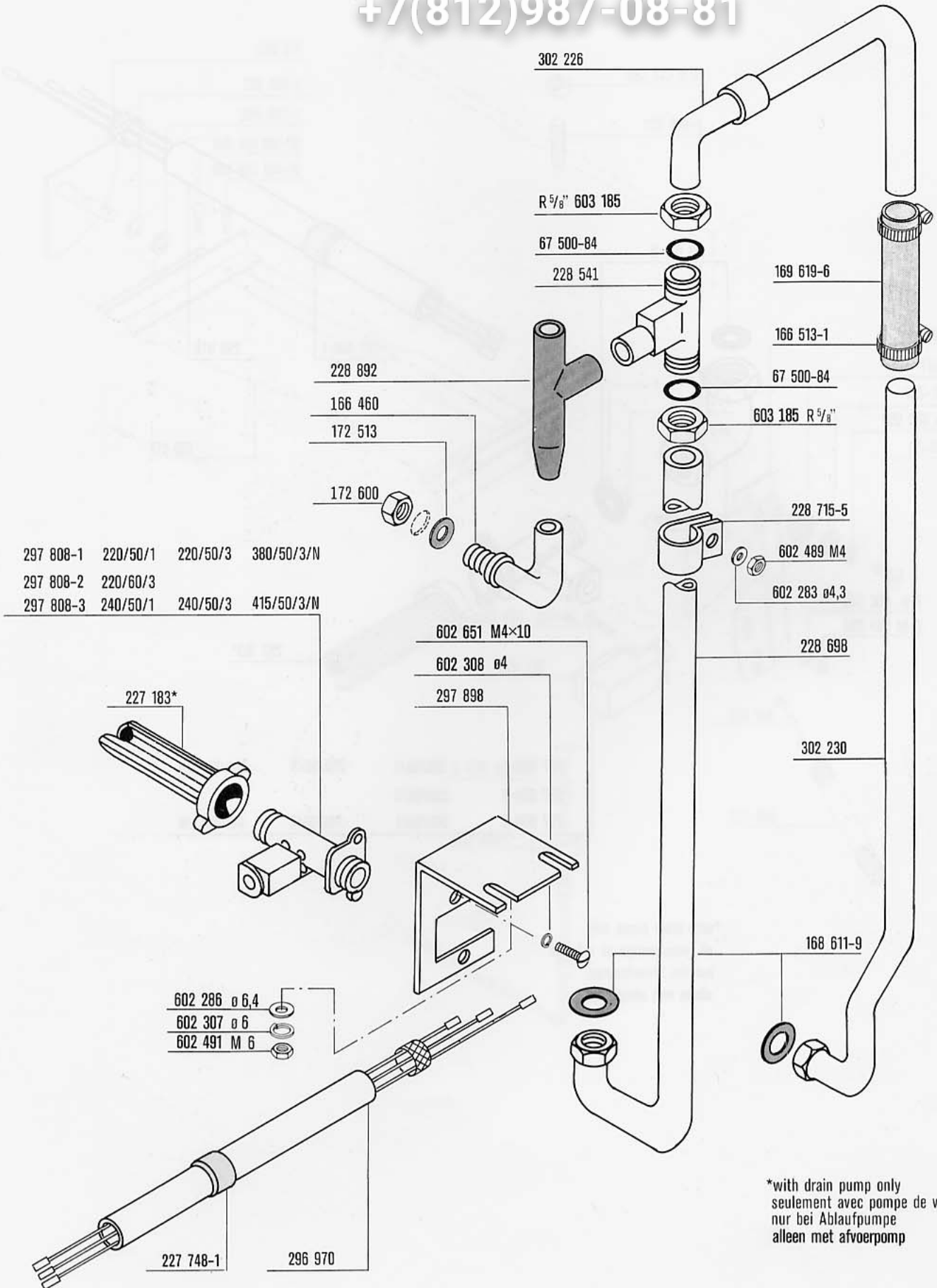

vsezip.ru

228 602 228 603 228 627*
 +7(812)987-08-81

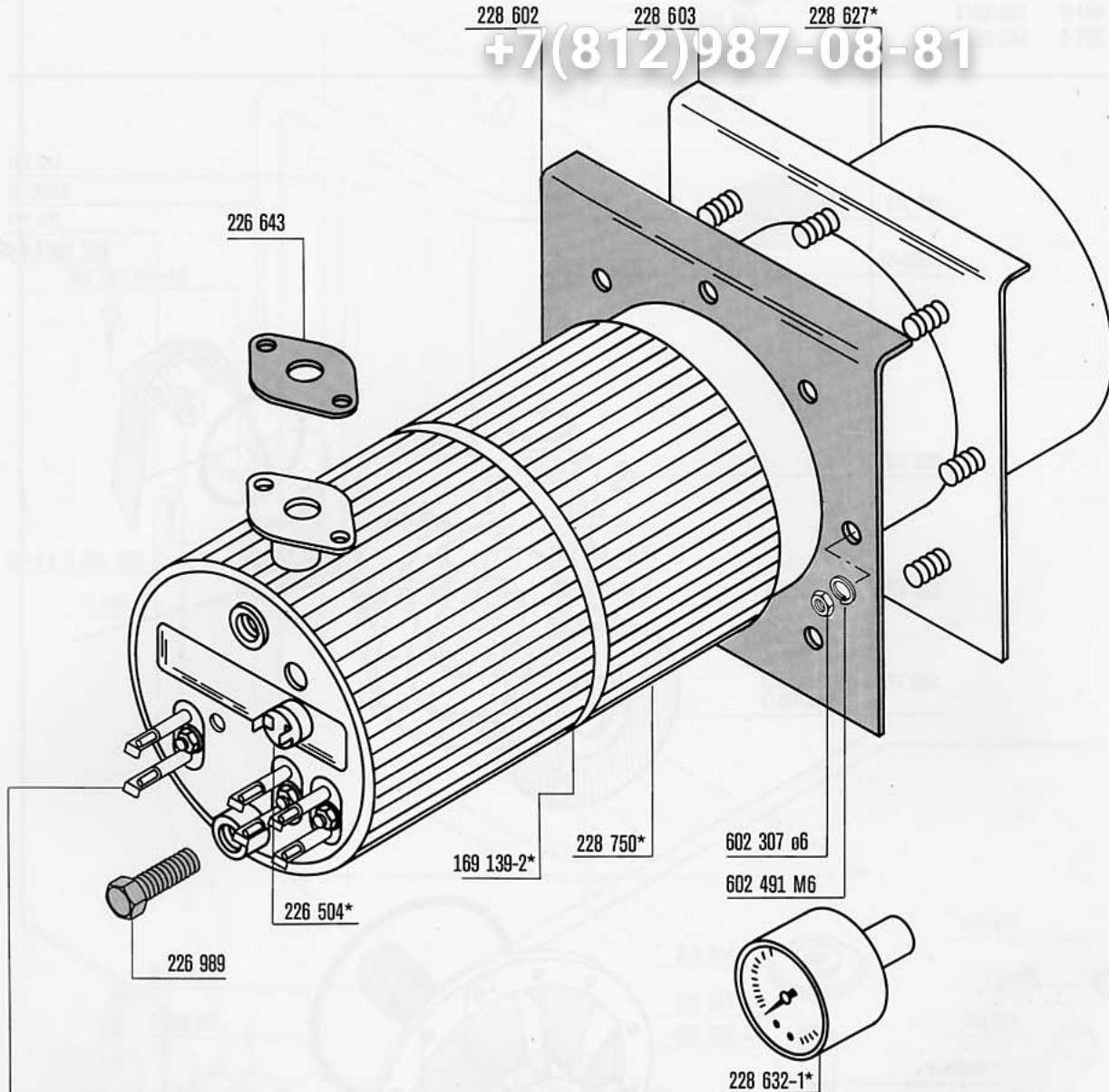

228 579-1*	2,5 kW	380/50/3 380/50/3/N
228 579-2*	2,5 kW	415/50/3 415/50/3/N
228 579-3*	2,5 kW	440/60/3
227 953-1*	2 kW	220/50/3 220/60/3 380/50/3 380/50/3/N
227 953-2*	2 kW	240/50/3 415/50/3 415/50/3/N
227 953-3*	2 kW	440/60/3
165 099-1*	1,5 kW	220/50/1 220/50/3 220/60/3 380/50/3 380/50/3/N
165 099-2*	1,5 kW	240/50/1 240/50/3 415/50/3 415/50/3/N
165 099-3*	1,5 kW	415/50/3/N 440/60/3

assembly incl.*	228 626-3	7,5 kW	380/50/3 380/50/3/N
ensemble compr.*	228 626-4	7,5kW	415/50/3 415/50/3/N
komplett inkl.*	228 626-6	7,5 kW	440/60/3
	228 626-7	6 kW	220/50/3 220/60/3 380/50/3 380/50/3/N
	228 626-8	6 kW	240/50/3 415/50/3 415/50/3/N
	228 626-9	6 kW	440/60/3
	228 626-1	4,5 kW	220/50/1 220/50/3 220/60/3 380/50/3 380/50/3/N
	228 626-2	4,5 kW	240/50/1 240/50/3 415/50/3 415/50/3/N
	228 626-5	4,5 kW	440/60/3

172 981-1 220-380/50/3-N
 172 981-2 240-415/50/3-N
 172 981-6 220/60/3
 172 981-5 440/60/3

vsezip.ru

+7(812)987-08-81

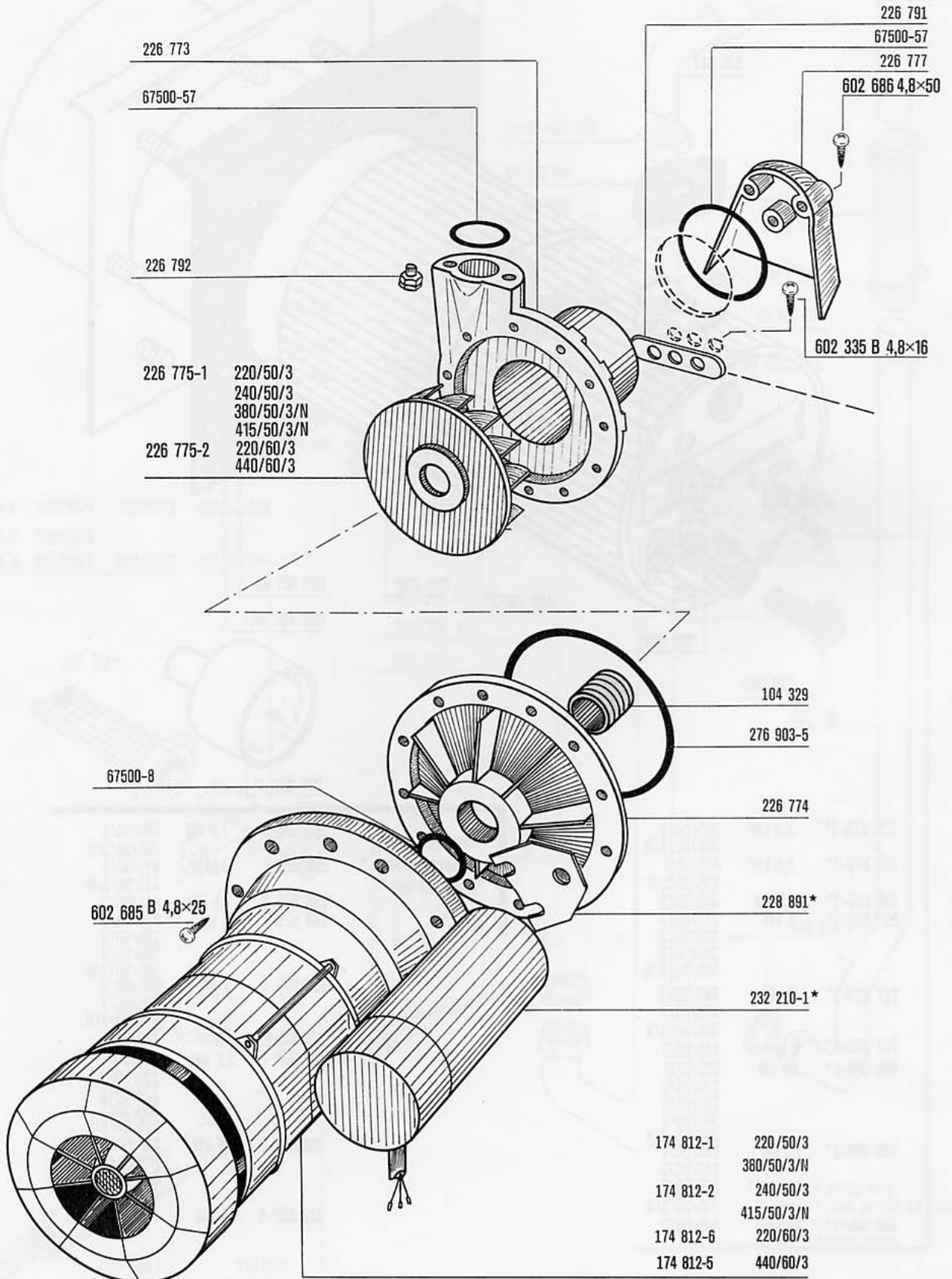

*only / seulement / nur / alleen 220-240/50/1

vsezip.ru

(812)987-08-81

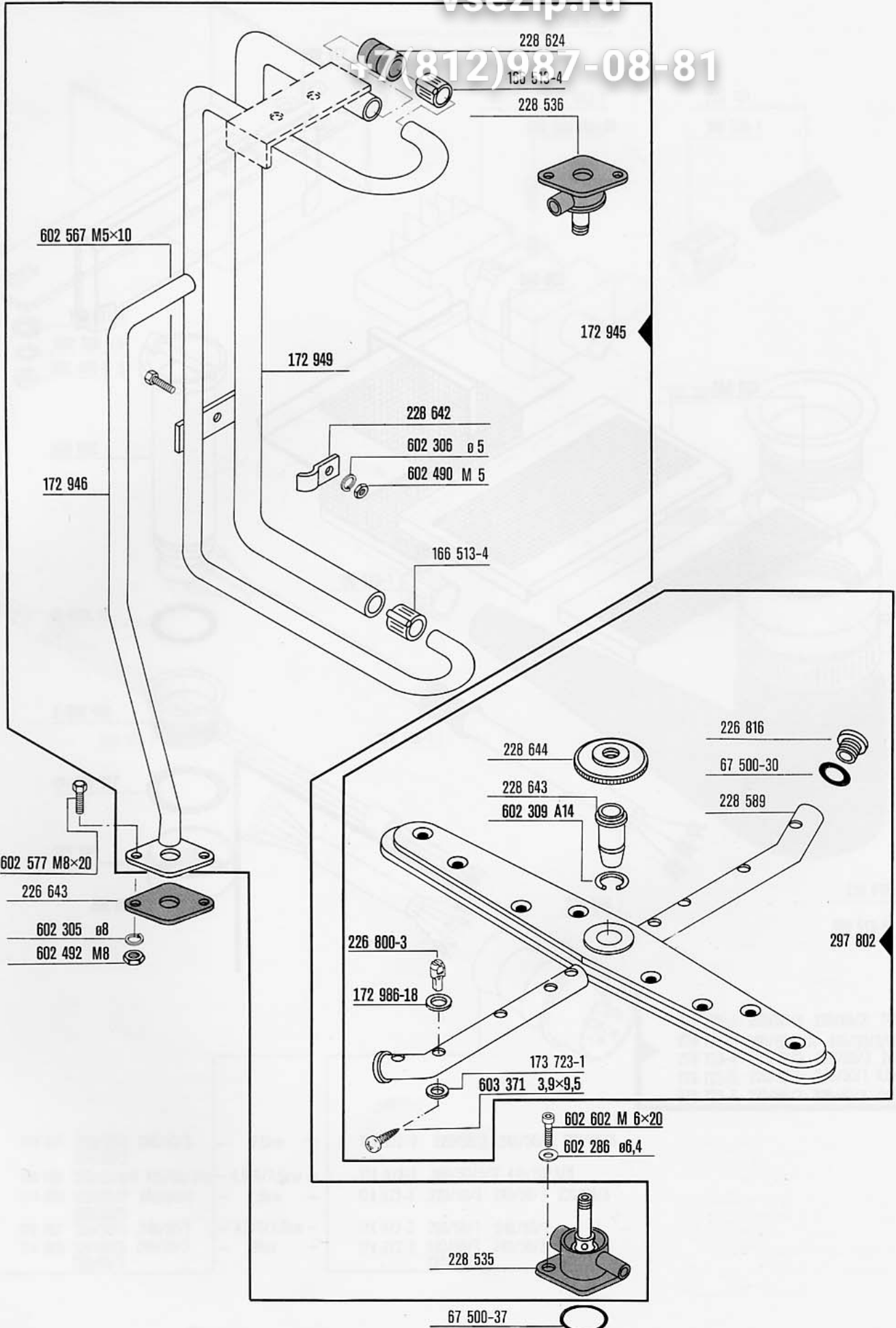

vsezip.ru

+7(812)987-08-81

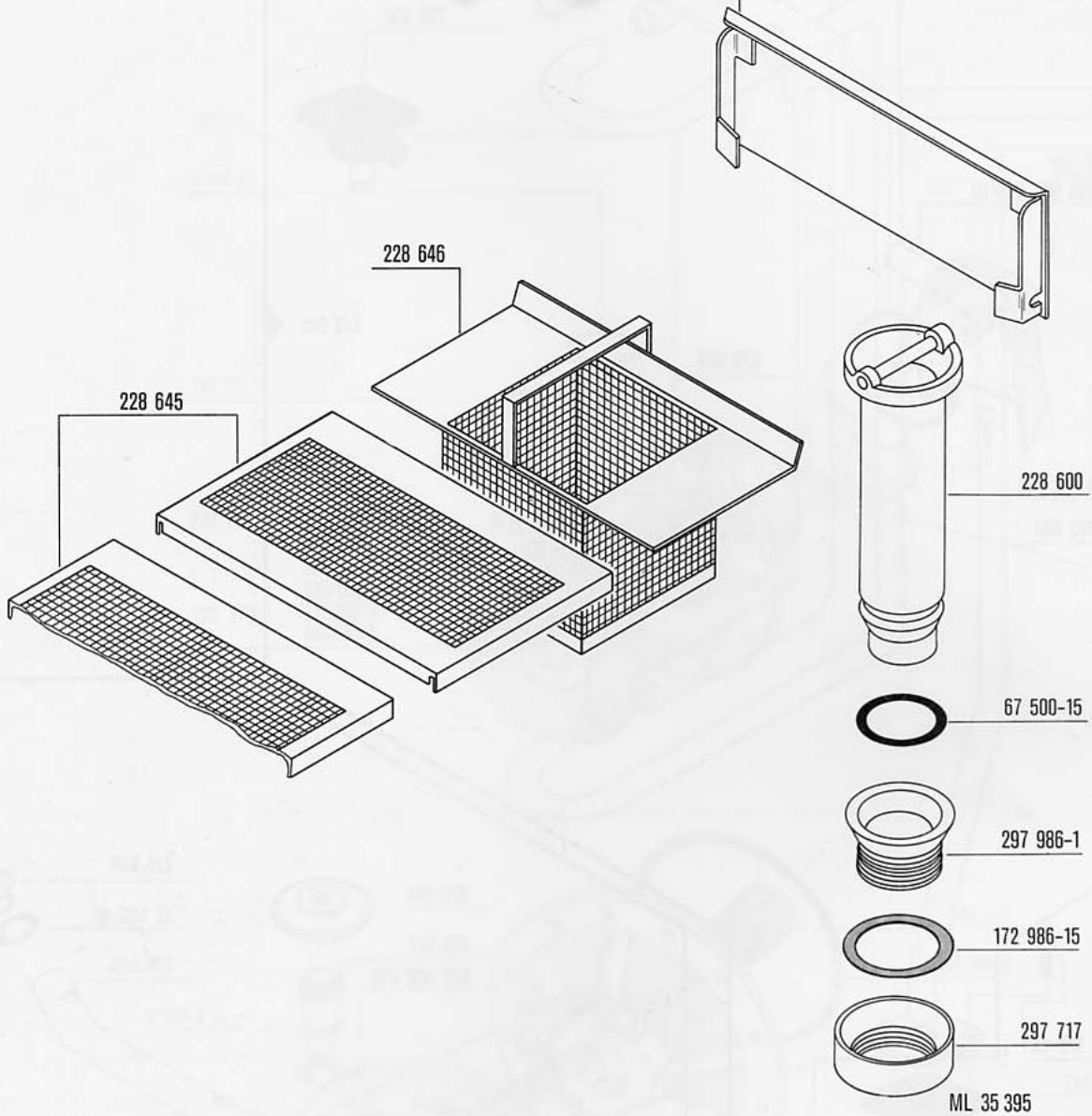

vsezip.ru

228 923

+7(812)987-08-81

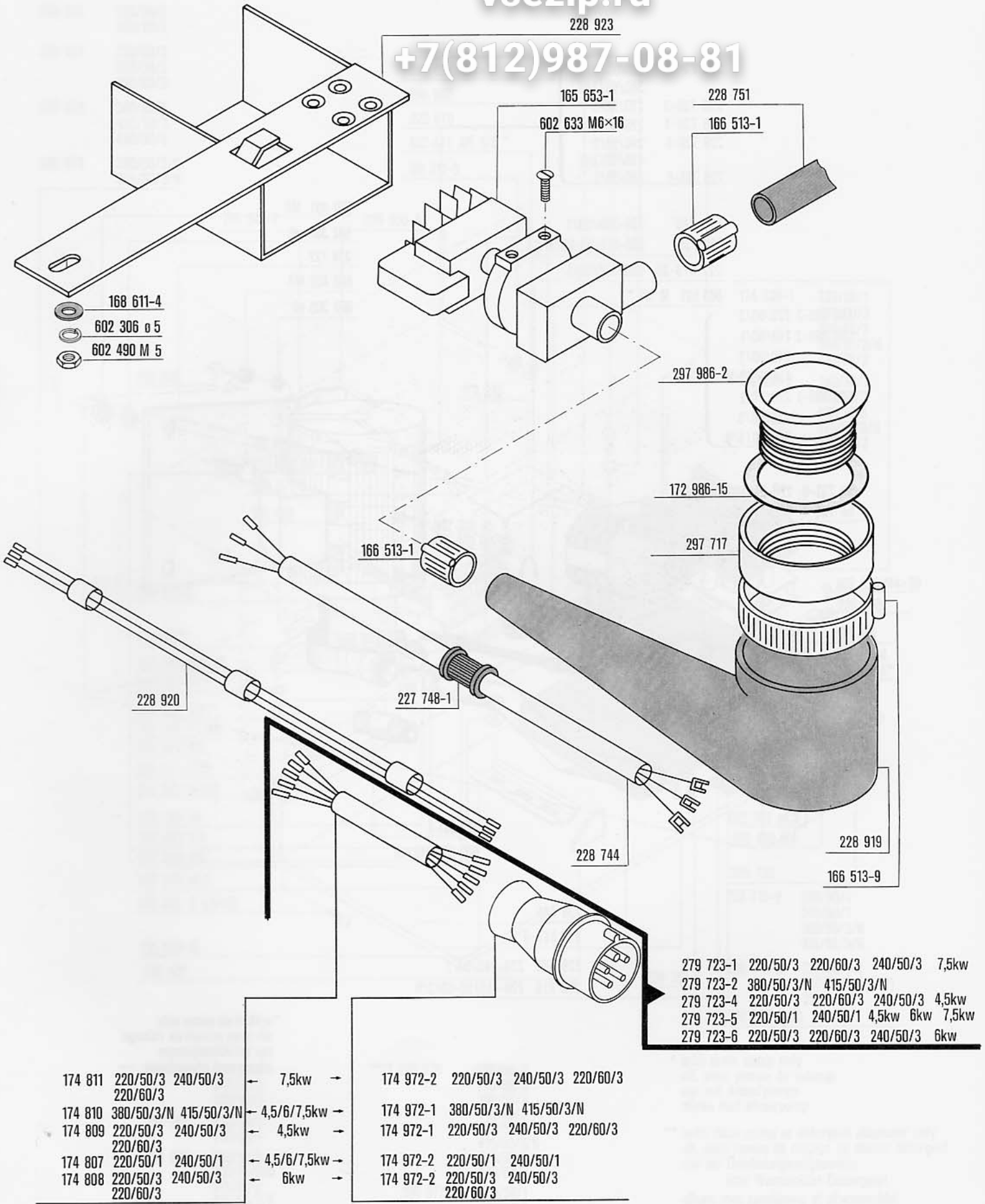

vsezip.ru

+7(812)987-08-81

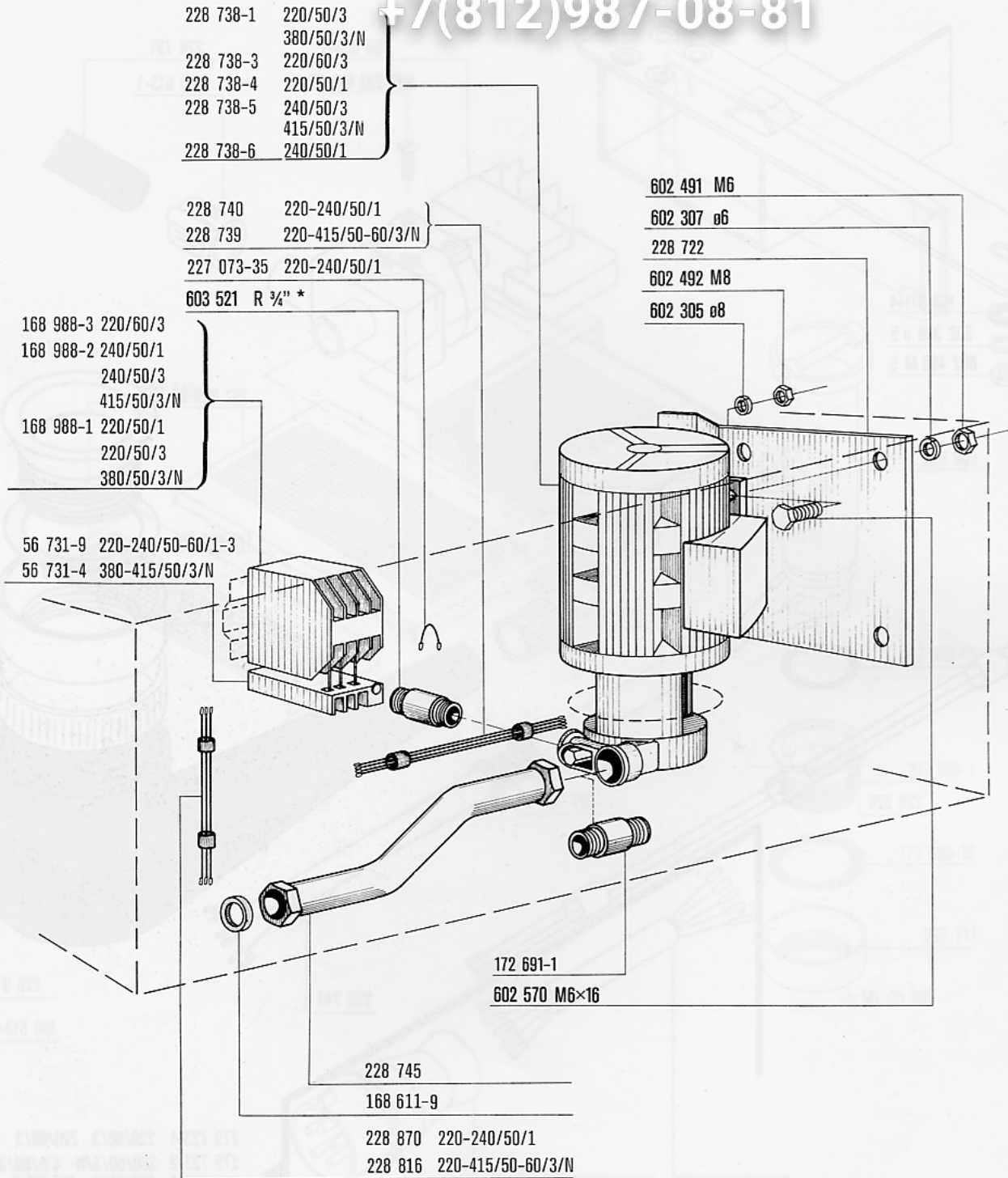

* with drain pump only
 slt. avec pompe de vidange
 nur bei Ablaufpumpe
 alleen met afvoerpomp

vsezip.ru

+7(812)987-08-81

296 975	220/50/1 240/50/1
296 974	220/50/3 240/50/3 220/60/3
296 972	380/50/3 415/50/3 440/60/3
296 973	380/50/3/N 415/50/3/N

602 311	ø4,3
602 611	4×0
296 980	
226 970	
602 471 AR	3/8"
168 611-9	

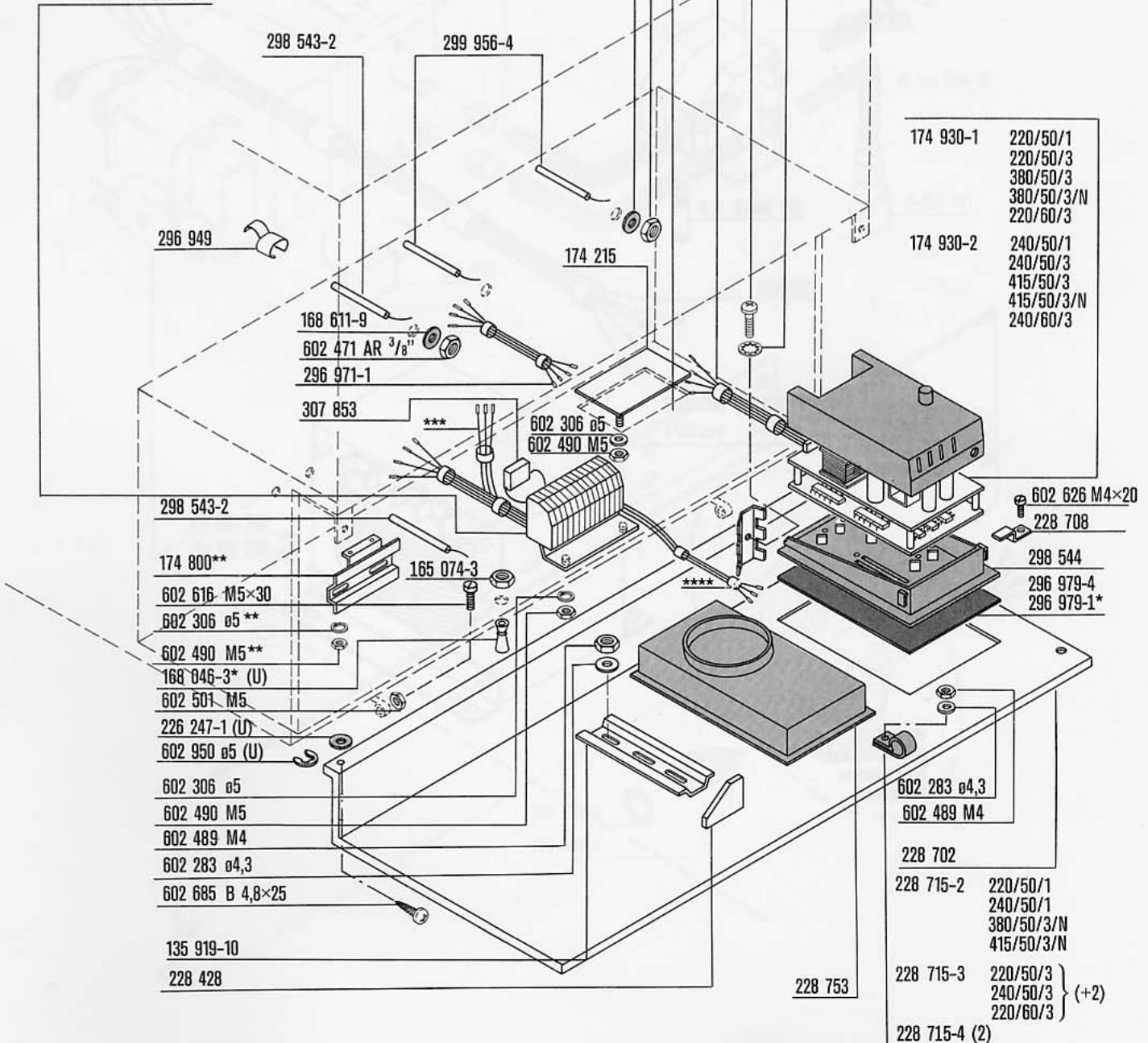

174 930-1	220/50/1 220/50/3 380/50/3 380/50/3/N 220/60/3
174 930-2	240/50/1 240/50/3 415/50/3 415/50/3/N 240/60/3

298 543-2	
174 800**	
602 616	M5×30
602 306	ø5 **
602 490	M5**
168 046-3*	(U)
602 501	M5
226 247-1	(U)
602 950	ø5 (U)
602 306	ø5
602 490	M5
602 489	M4
602 283	ø4,3
602 685 B	4,8×25

135 919-10	
228 428	

602 626	M4×20
228 708	
298 544	
296 979-4	
296 979-1*	

602 283	ø4,3
602 489	M4
228 702	

228 715-2	220/50/1 240/50/1 380/50/3/N 415/50/3/N
-----------	--

228 715-3	220/50/3 240/50/3 220/60/3	(+2)
228 715-4	(2)	

*** 296 984	220/50/3 240/50/3 220/60/3
296 985	220/50/1 240/50/1
296 982	380/50/3 380/50/3/N 415/50/3 415/50/3/N 440/60/3

**** 296 976	220/50/3 240/50/3 380/50/3 415/50/3 380/50/3/N 415/50/3/N
296 977	220/50/1 240/50/1

* with drain pump only
slt. avec pompe de vidange
nur mit Ablaufpumpe
alleen met afvoerpomp

** with rinse pump or detergent dispenser only
slt. avec pompe de rinçage ou doseur détergent
nur bei Drucksteigerungspumpe
oder Waschmittel-Dosiergerät
alleen met spoelpomp of afwasmiddel
doseerapparaat

vsezip.ru

+7(812)987-08-81

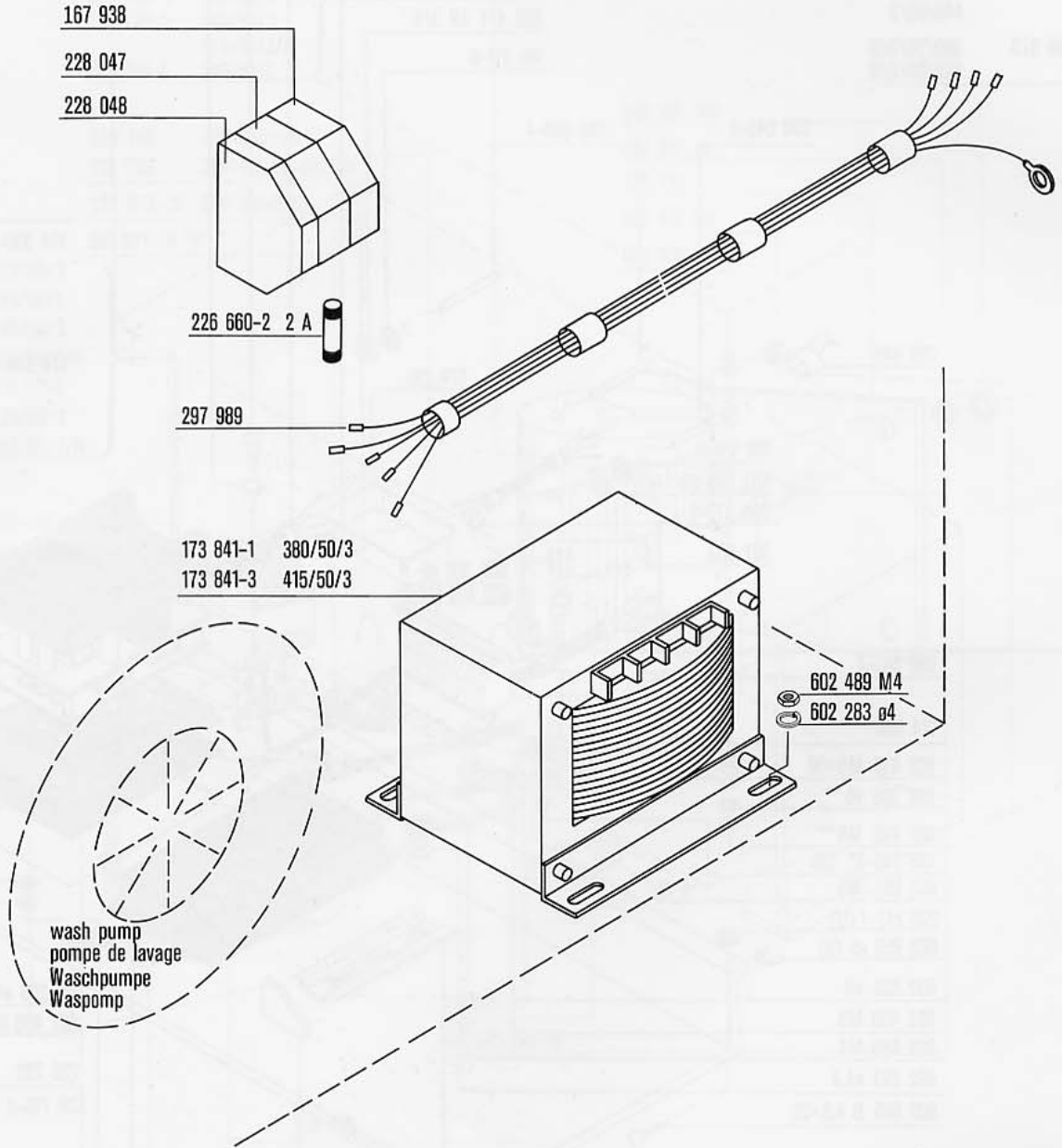

vsezip.ru

+7(812)987-08-81

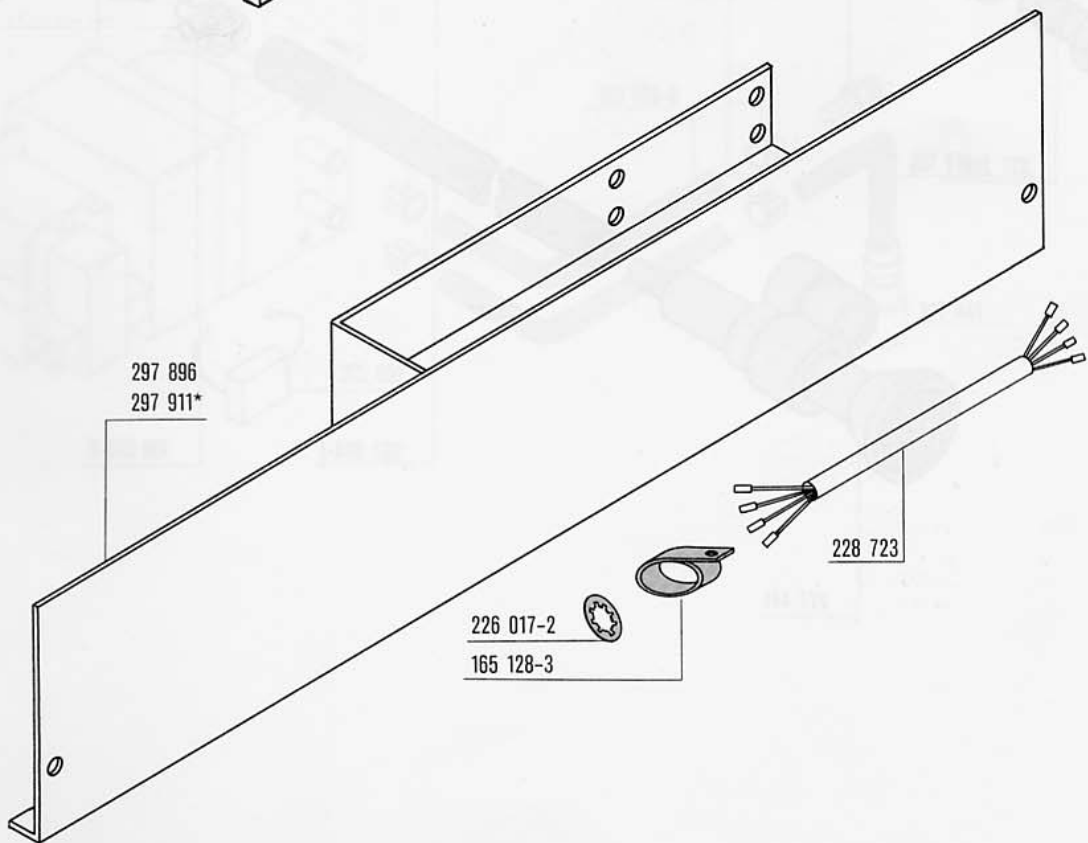
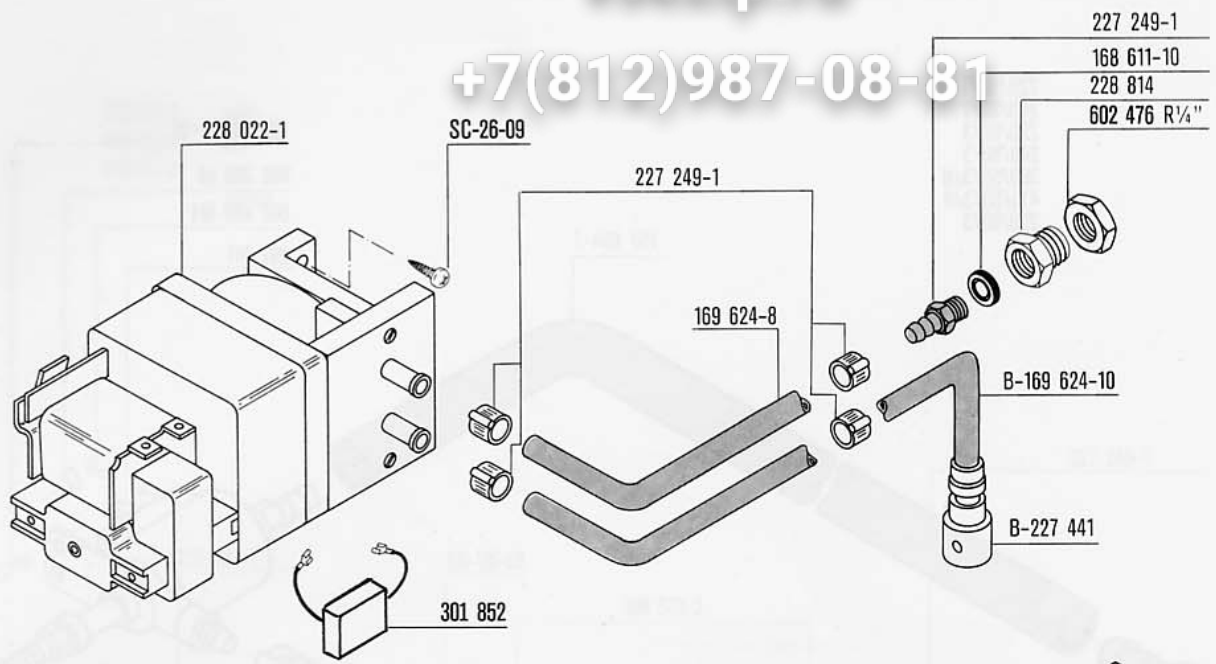

*900 mm machine height
900 mm hauteur de la machine
900 mm Maschinenhöhe
900 mm hoogte

vsezip.ru

+7(812)987-08-81

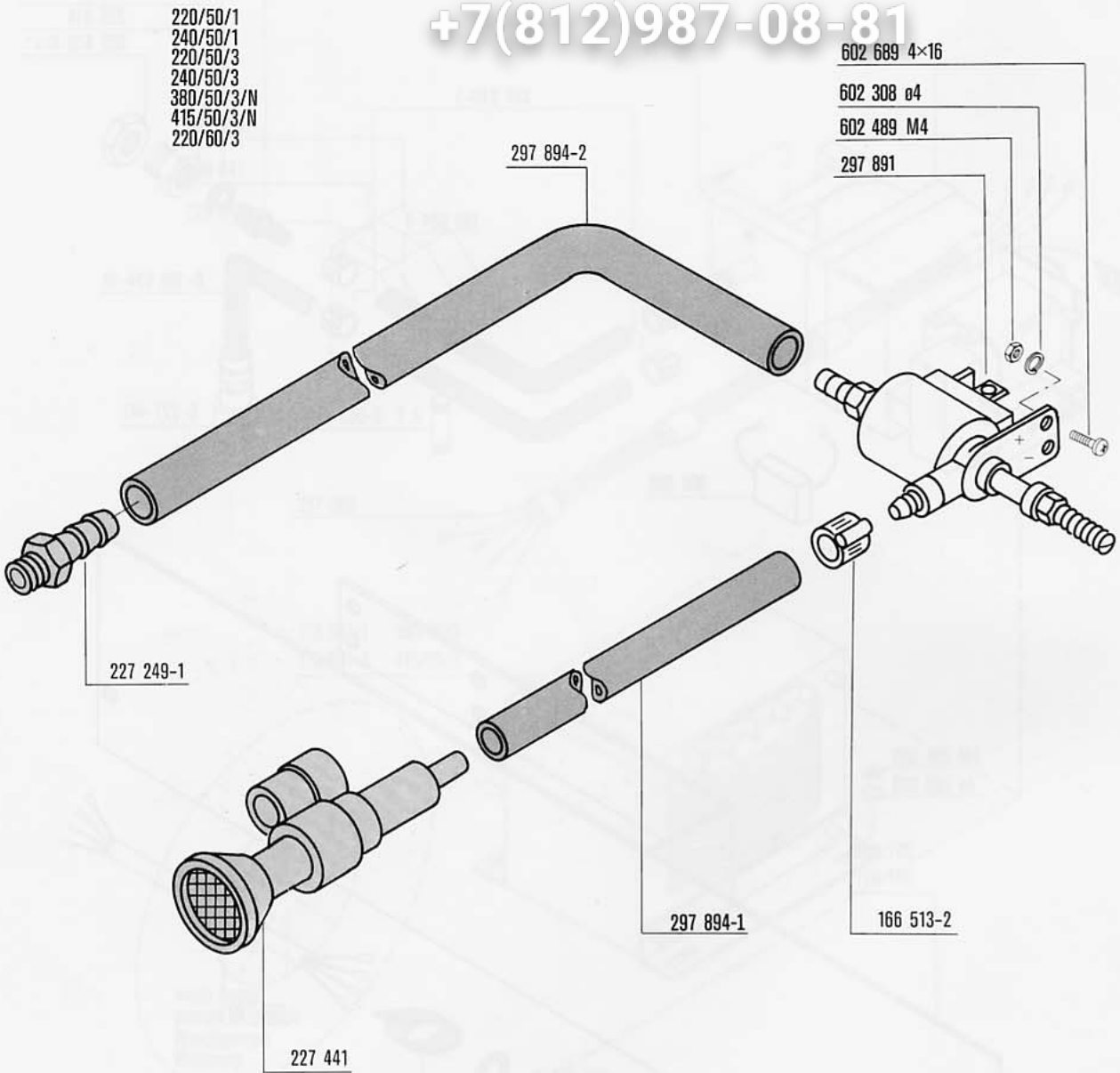

vsezip.ru

+7(812)987-08-81

380/50/3 only
415/50/3 sit.
440/60/3 nur
alleen

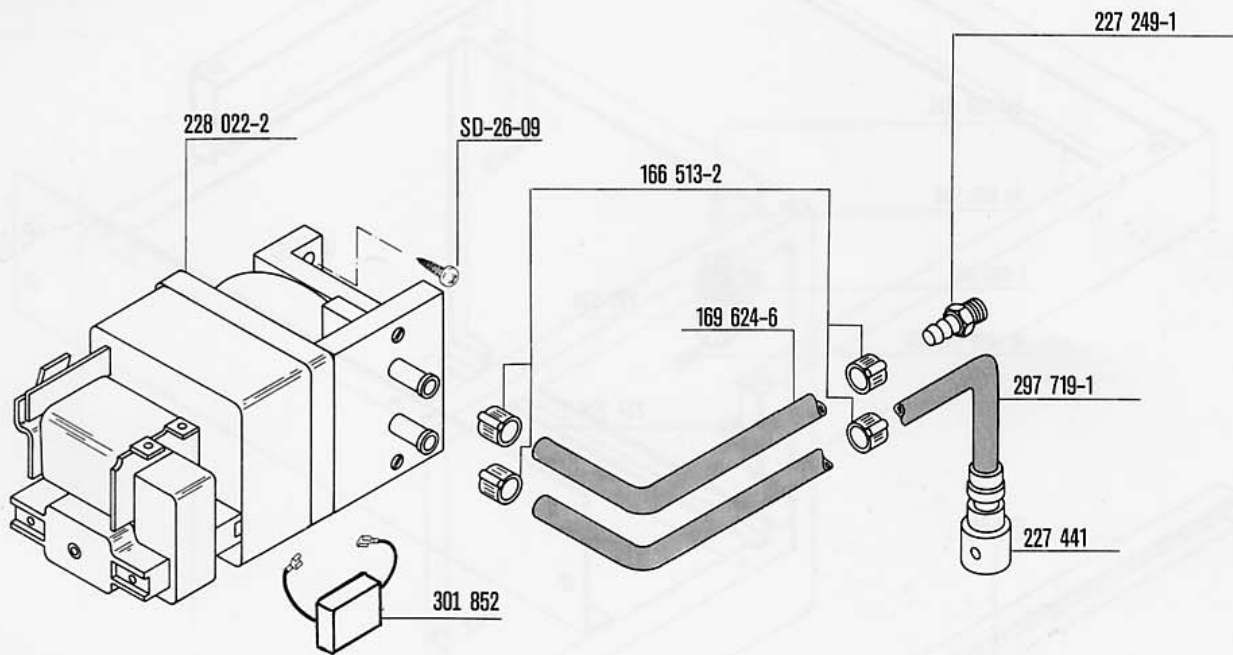

vsezip.ru

+7(812)987-08-81

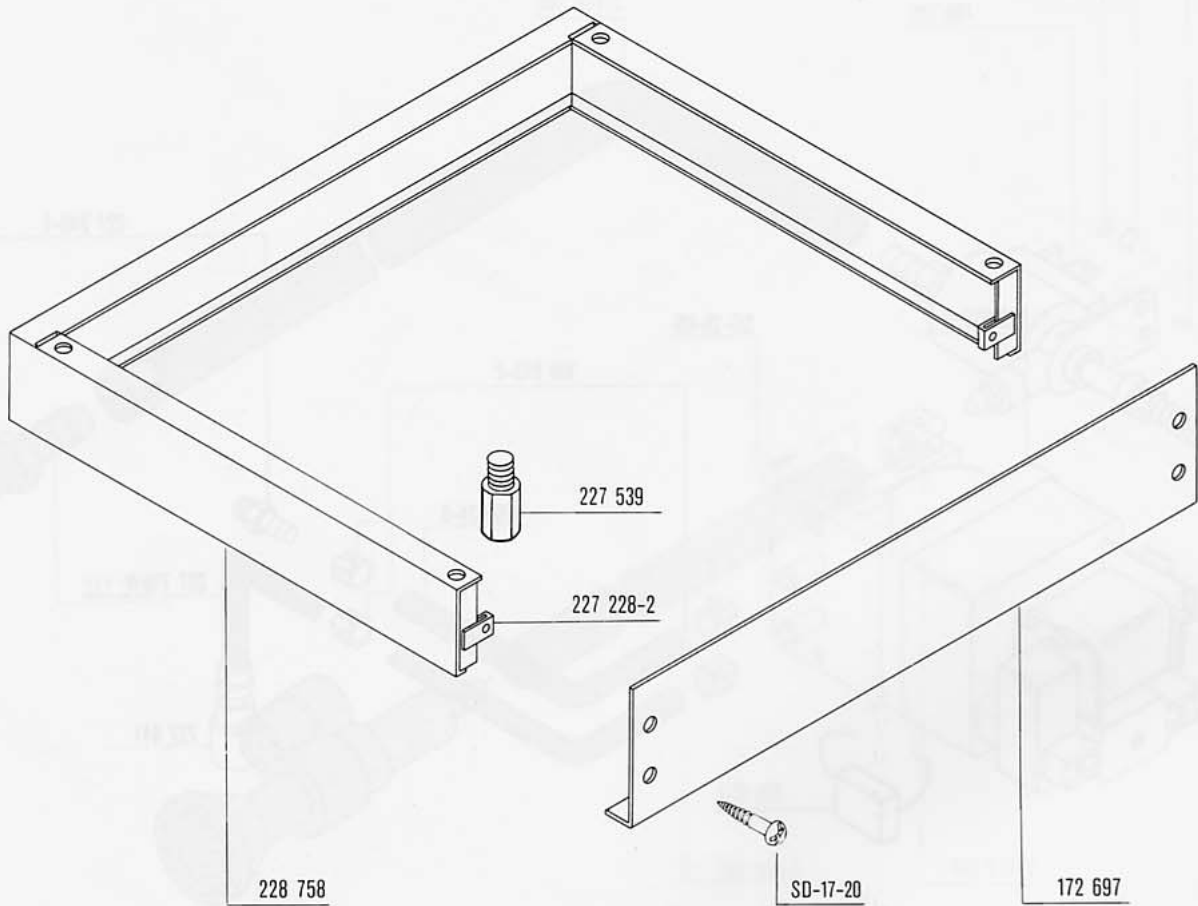

vsezip.ru

+7(812)987-08-81

