

Зип Общепит

vsezip.ru

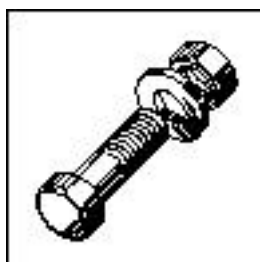

UW135 / H



Spare Parts

Contents

Frame and panels	4
Hood mecanic	5
Hood guide	6
Hood	7
Wash and rinse system	8
Strainers	9
Racks and track	10
Pump	11
Drain	12
Tank heating and float switch	13
Temperature and conductivity probe	14
Hydraulic cylinder	15
Fill and hood hydraulic pipework	16
Rinse booster heater, electric 9 - 18 kW	17
Rinse booster heater, steam or hot water	18
Pipework – steam, hot water	19
Control box	20
Table and scrapping system	21
Pipework – rinse pressure pump	22
Rinse agent dispenser	23
Detergent dispenser	24
Vacuum breaker	25
Splash guard	26

Sommaire

Chassis et panneaux	4
Mécanique caisson	5
Glissière de caisson	6
Caisson	7
Système de lavage et de rinçage	8
Filtres	9
Paniers et rails	10
Pompe	11
Vidange	12
Chauffage de bac et interrupteur à flotteur	13
Sondes de température et de conductivité	14
Cylindre hydraulique	15
Conduites de remplissage et d'hydraulique du caisson	16
Surchauffeur, électrique 9 - 18 kW	17
Surchauffeur, vapeur ou eau surchauffée	18
Conduite de vapeur, d'eau surchauffée	19
Coffret de commande	20
Table et système de pré-lavage	21
Conduite de la pompe de rinçage	22
Doseur de produit mouillant	23
Doseur de produit tensio-activ	24
Brise-vide	25
Tôle anti-éclaboussure	26

Inhalt

Tankgestell und Verkleidungen	4
Haubenmechanik	5
Haubenführung	6
Haube	7
Waschsystem	8
Siebsystem	9
Körbe und Laufschiene	10
Pumpe	11
Ablauf	12
Tankheizung und Schwimmerschalter	13
Temperatur- und Leitwertfühler	14
Hydrozylinder	15
Fülleitung und Haubenhydraulik	16
Durchlauferhitzer, elektrisch 9 - 18 kW	17
Durchlauferhitzer, Dampf oder Heißwasser	18
Rohrleitungen Dampf, Heißwasser	19
Schaltkasten	20
Tisch- und Vorspülsystem	21
Rohrleitungen Drucksteigerungspumpe	22
Netzmittel Dosiergerät	23
Reinigungsmittel Dosiergerät	24
Rücksaugeverhinderer	25
Spritzblech	26

Inhoud

Tank en panelen	4
Kapmechanik	5
Kapgeleiding	6
Kap	7
Was en spoelsysteem	8
Zeeven	9
Rekken en rekken rails	10
Pomp	11
Afvoer	12
Tankverwarming en zwemschakelaar	13
Termometer en huls en geleidingsmeting	14
Hydraulische cylinder	15
Vulleiding en hoed hydraulic	16
Booster, elektrisch 9 - 18 kW	17
Booster, stoom of heet water	18
Waterpijp – stoom, heet water	19
Schakelkast	20
Tafel en voorspoelsysteem	21
Waterpijp voor spoeldrukomp	22
Spoelmiddel-doseerapparaat	23
Wasmiddel-doseerapparaat	24
Vacuumbreaker	25
Spat plaat	26

+7(812)987-08-81

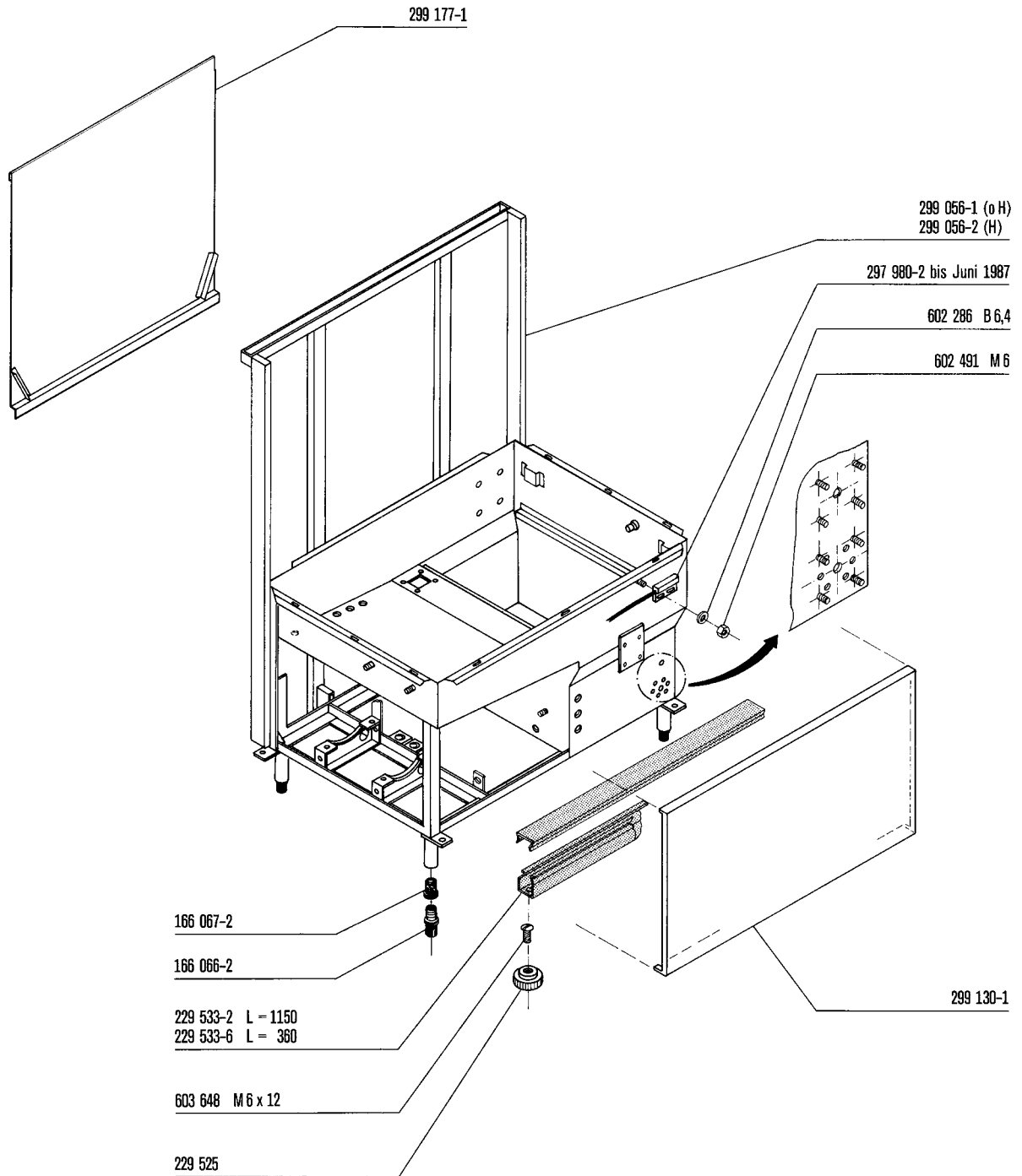

+7(812)987-08-81

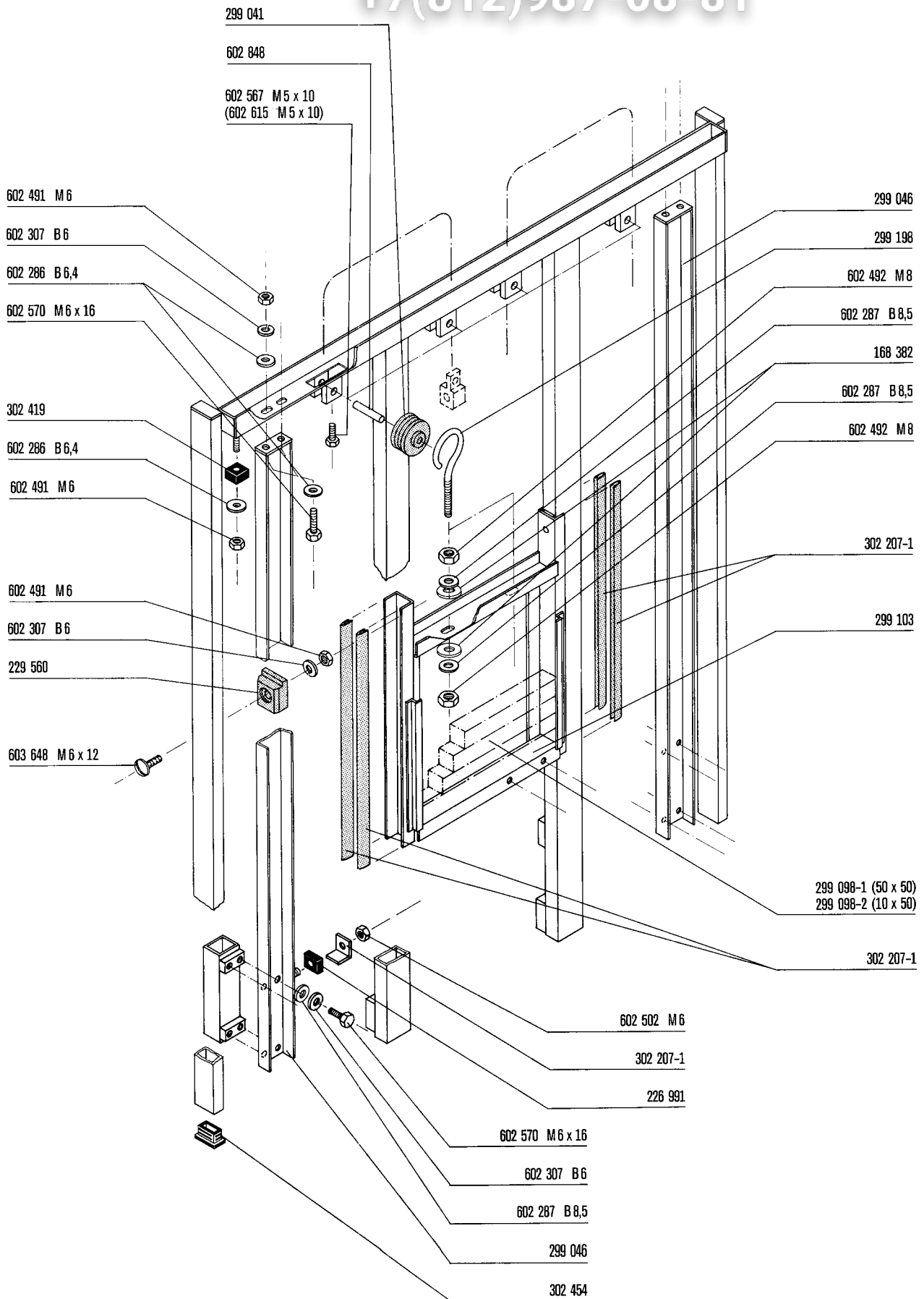

+7(812)987-08-81

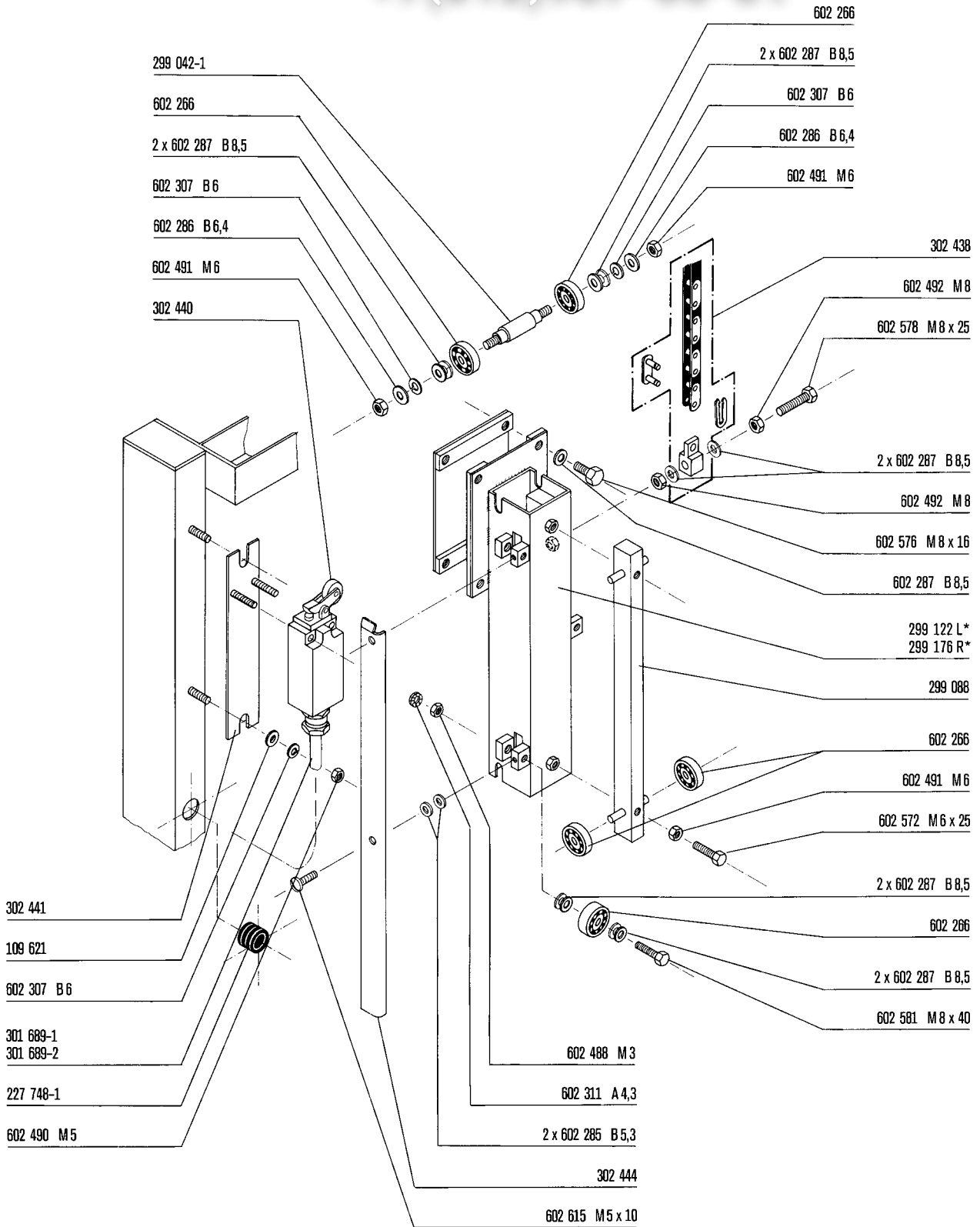

*L = left
gauche
links
links

*R = right
droite
rechts
rechts

+7(812)987-08-81

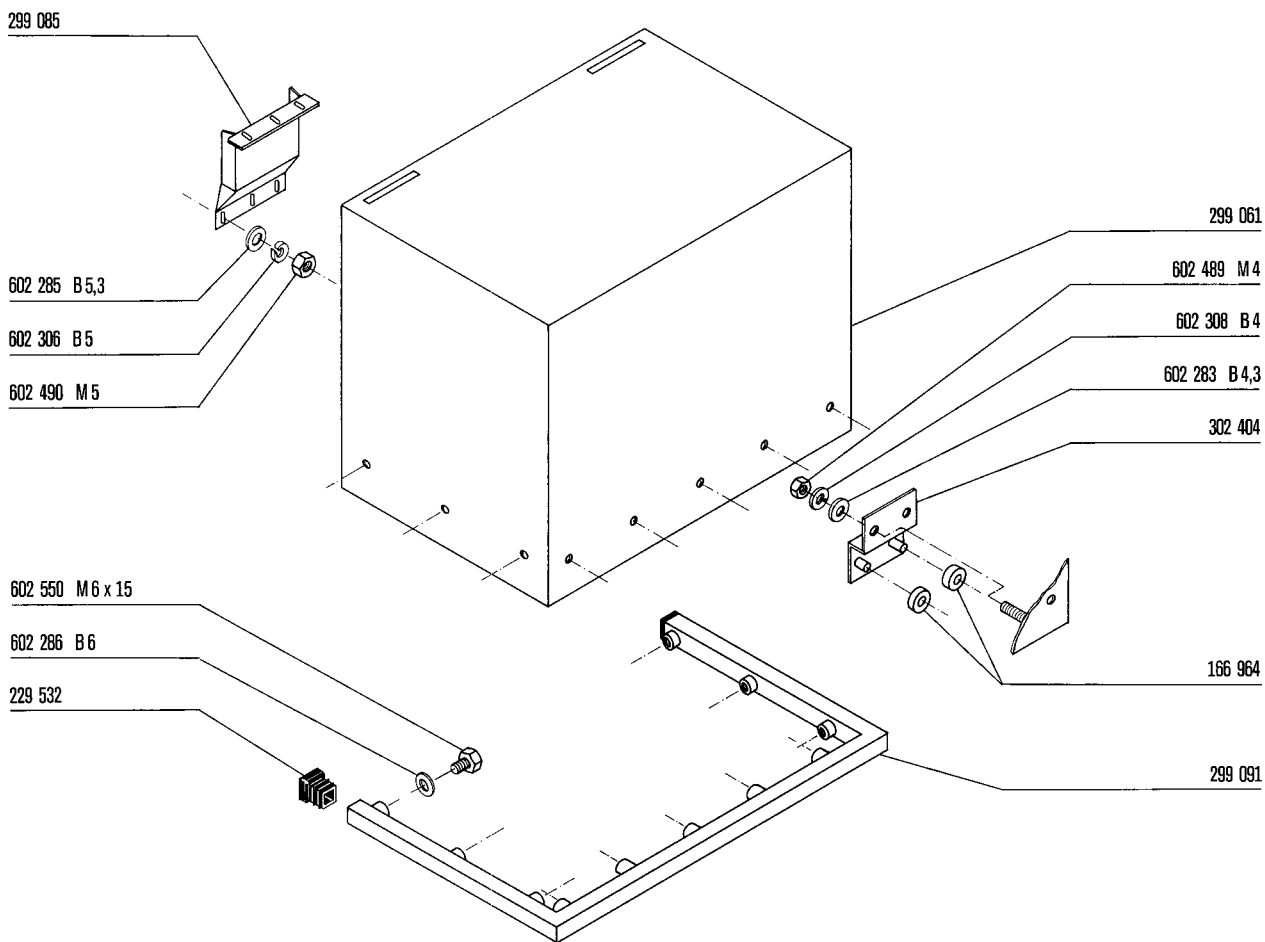

+7(812)987-08-81

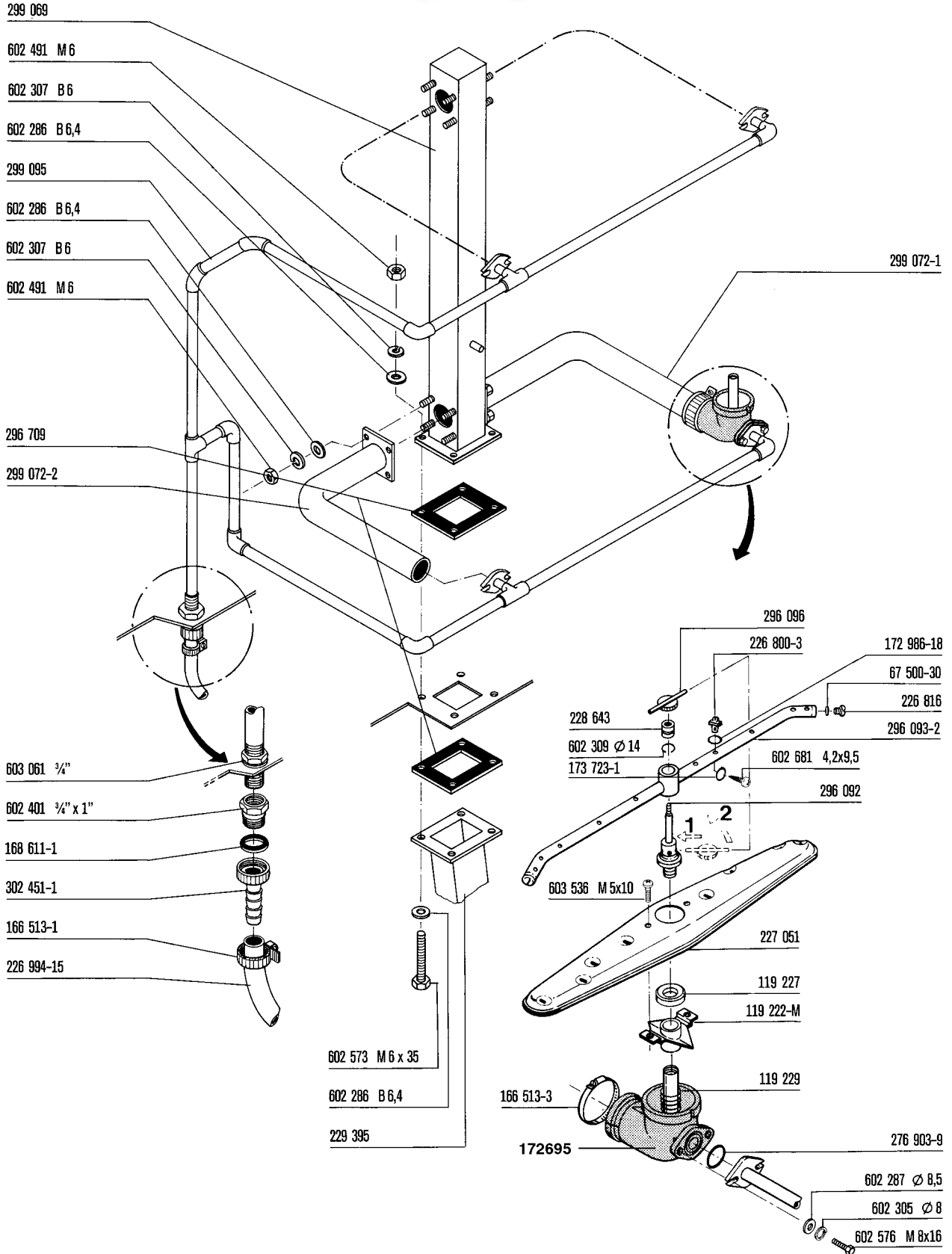

+7(812)987-08-81

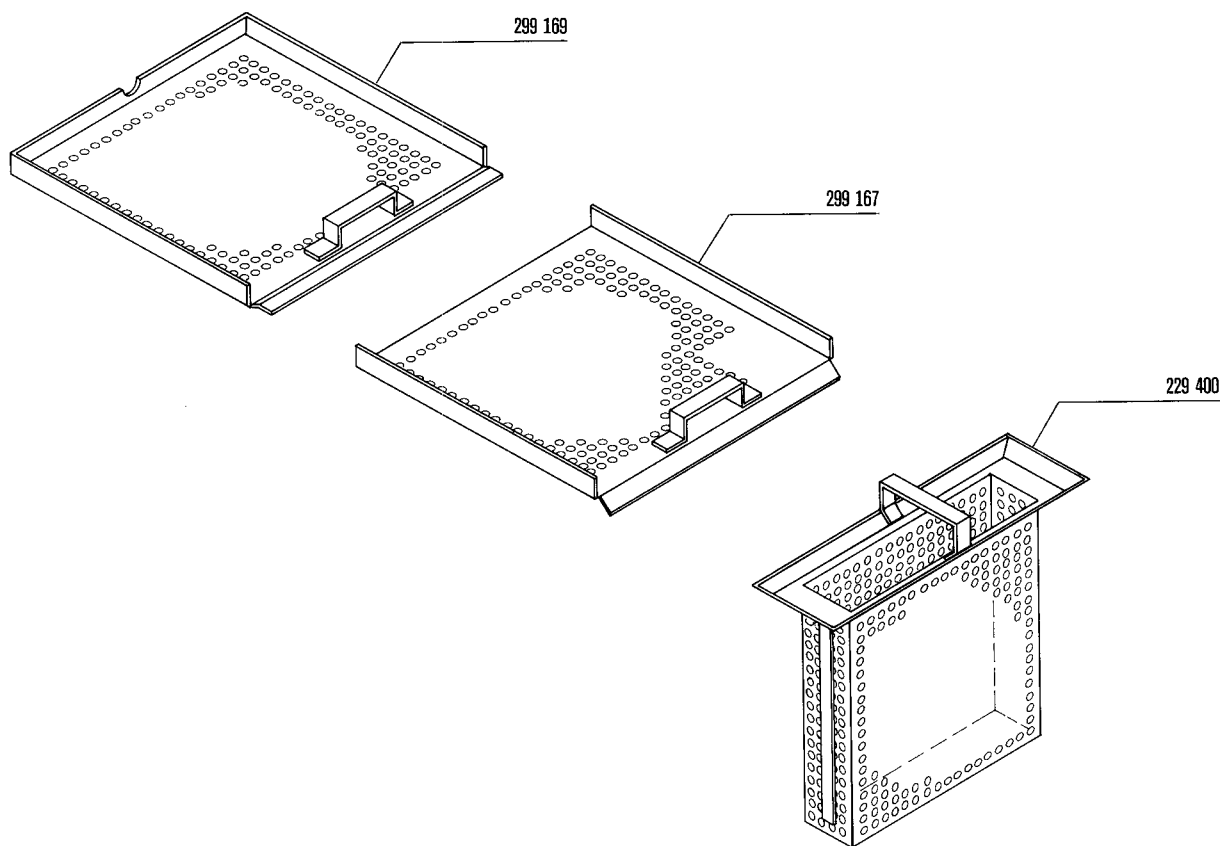

+7(812)987-08-81

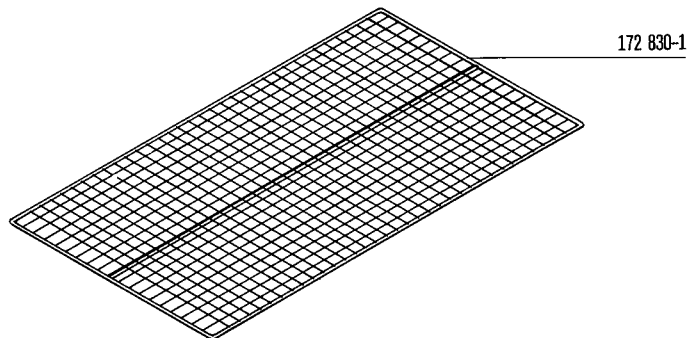
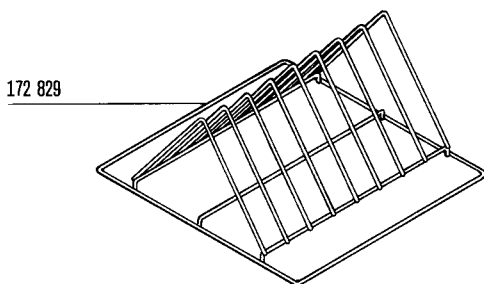
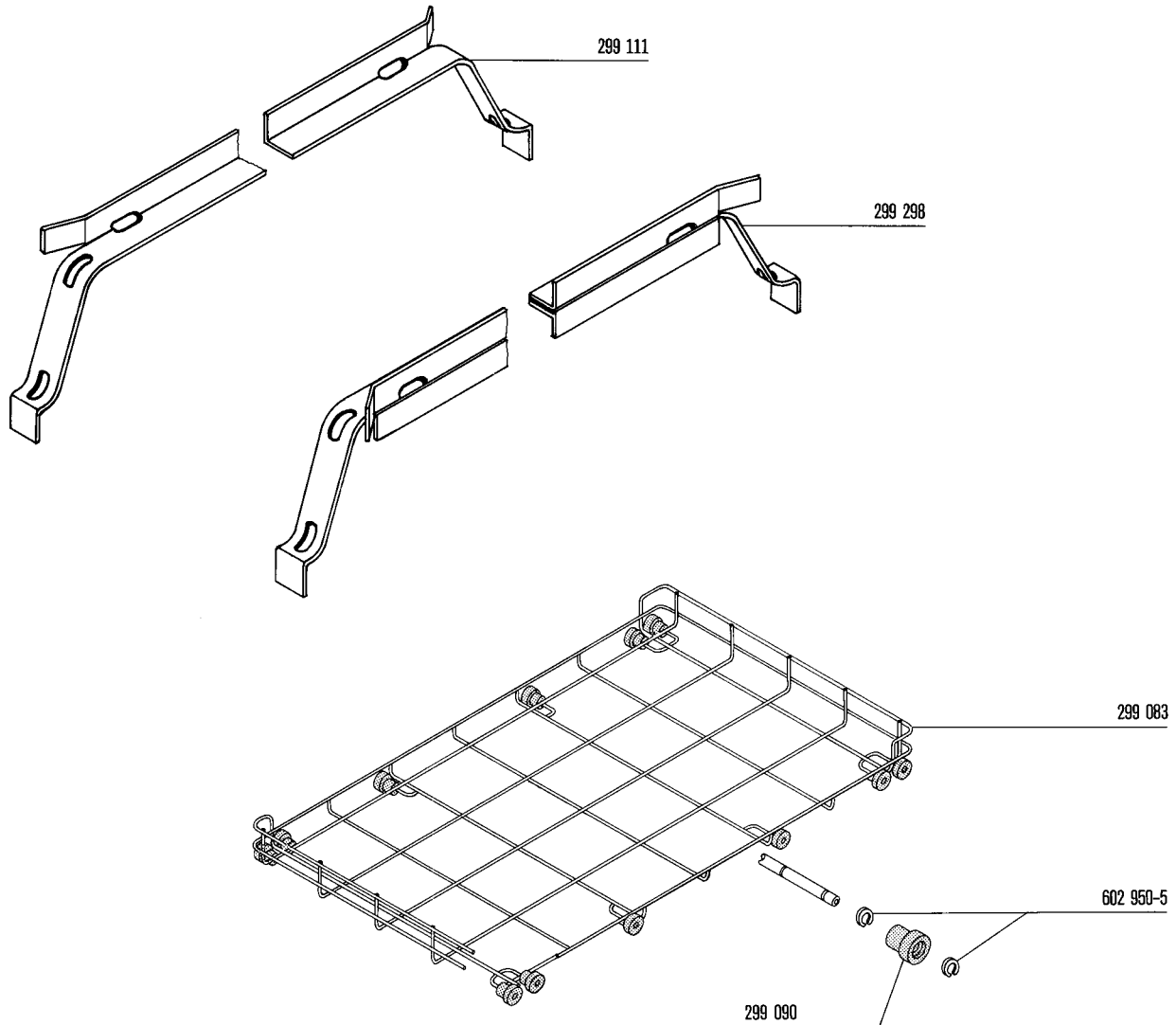

+7(812)987-08-81

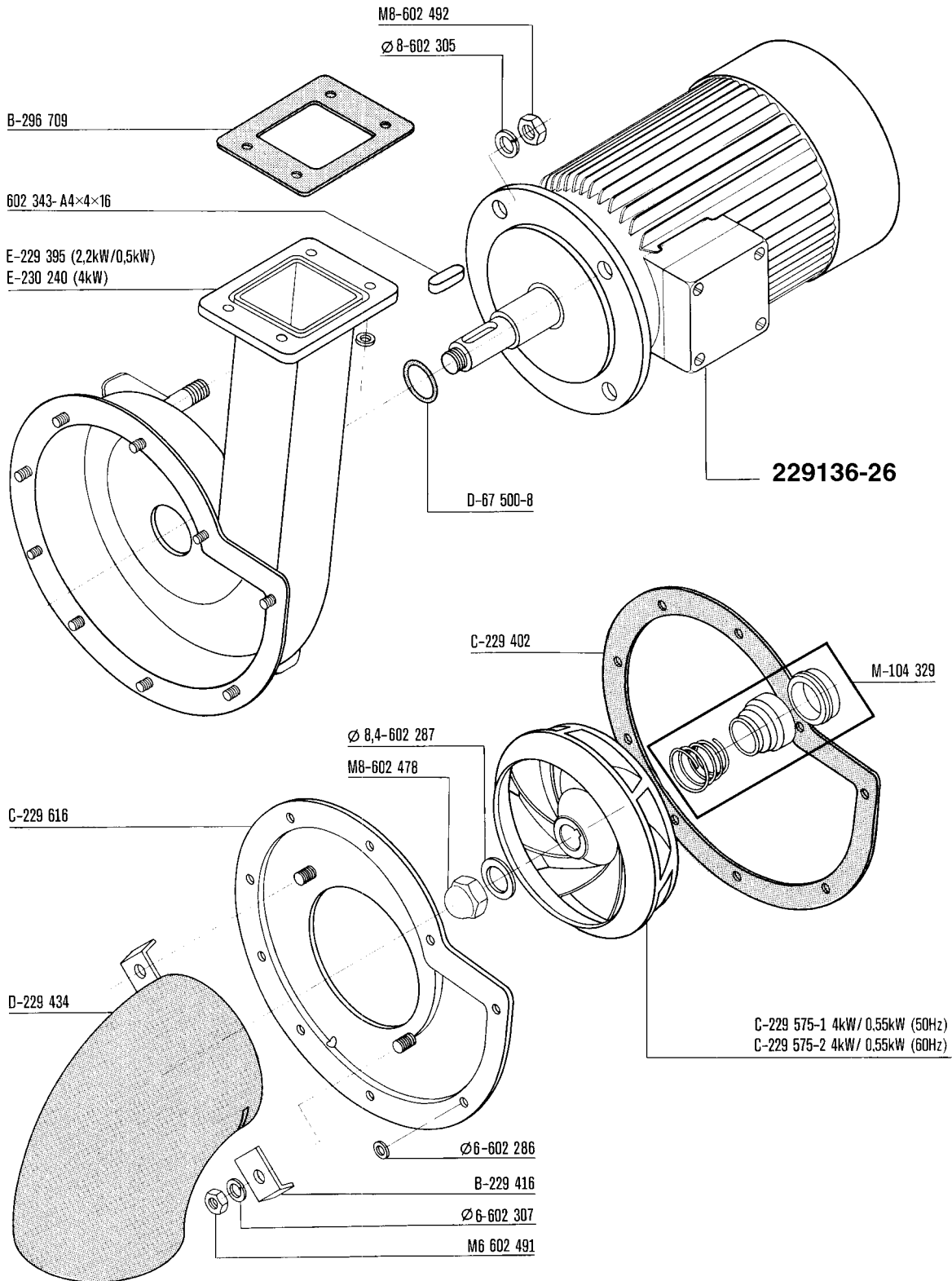

+7(812)987-08-81

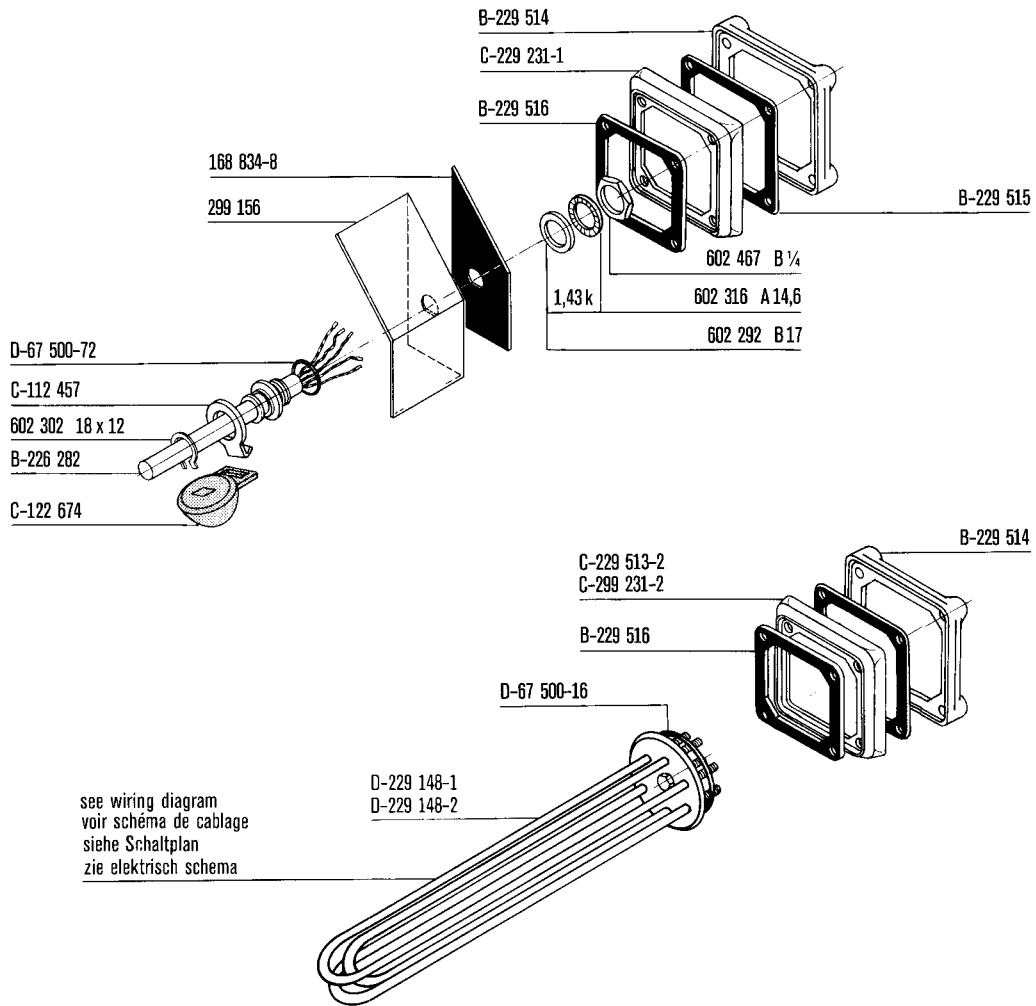

+7(812)987-08-81

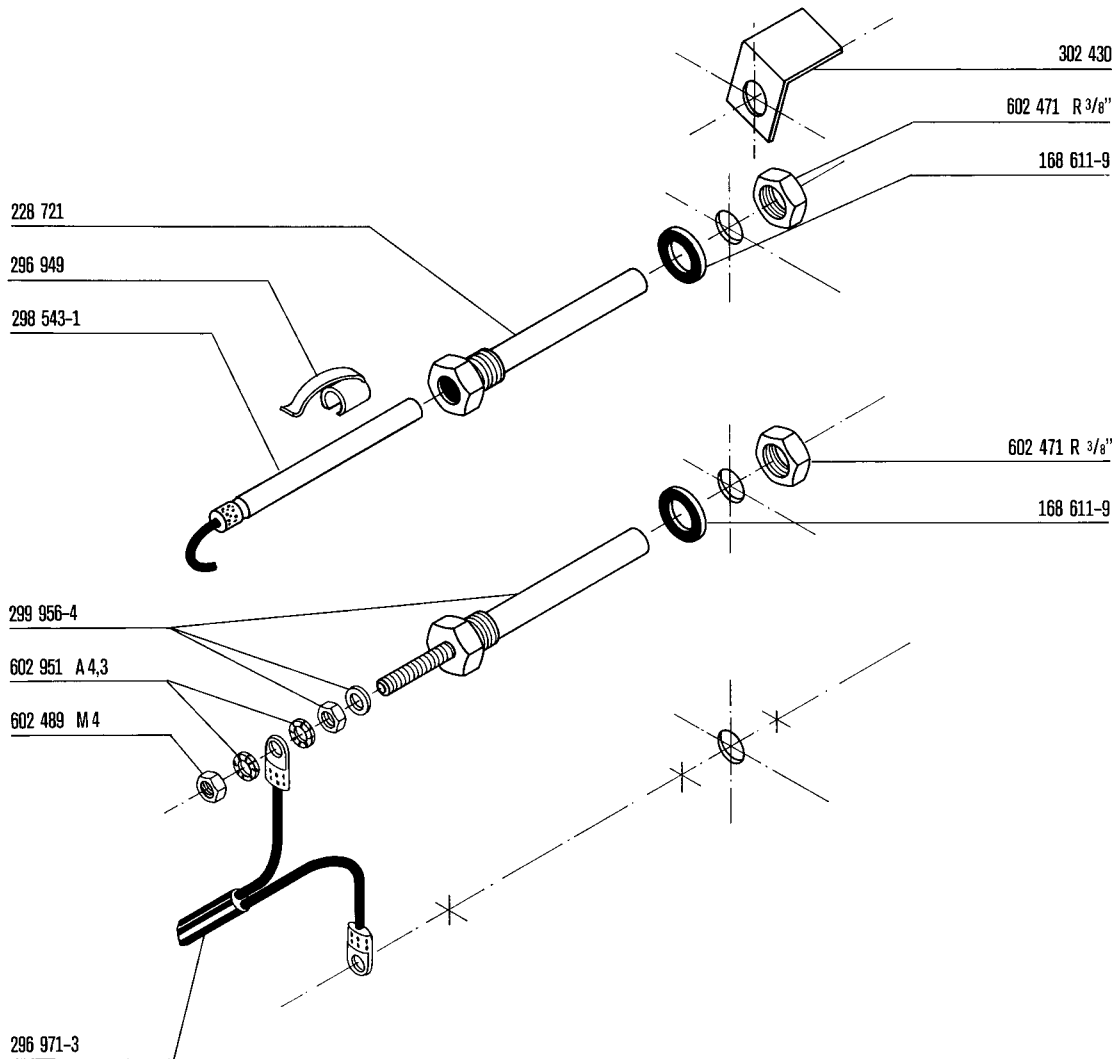

+7(812)987-08-81

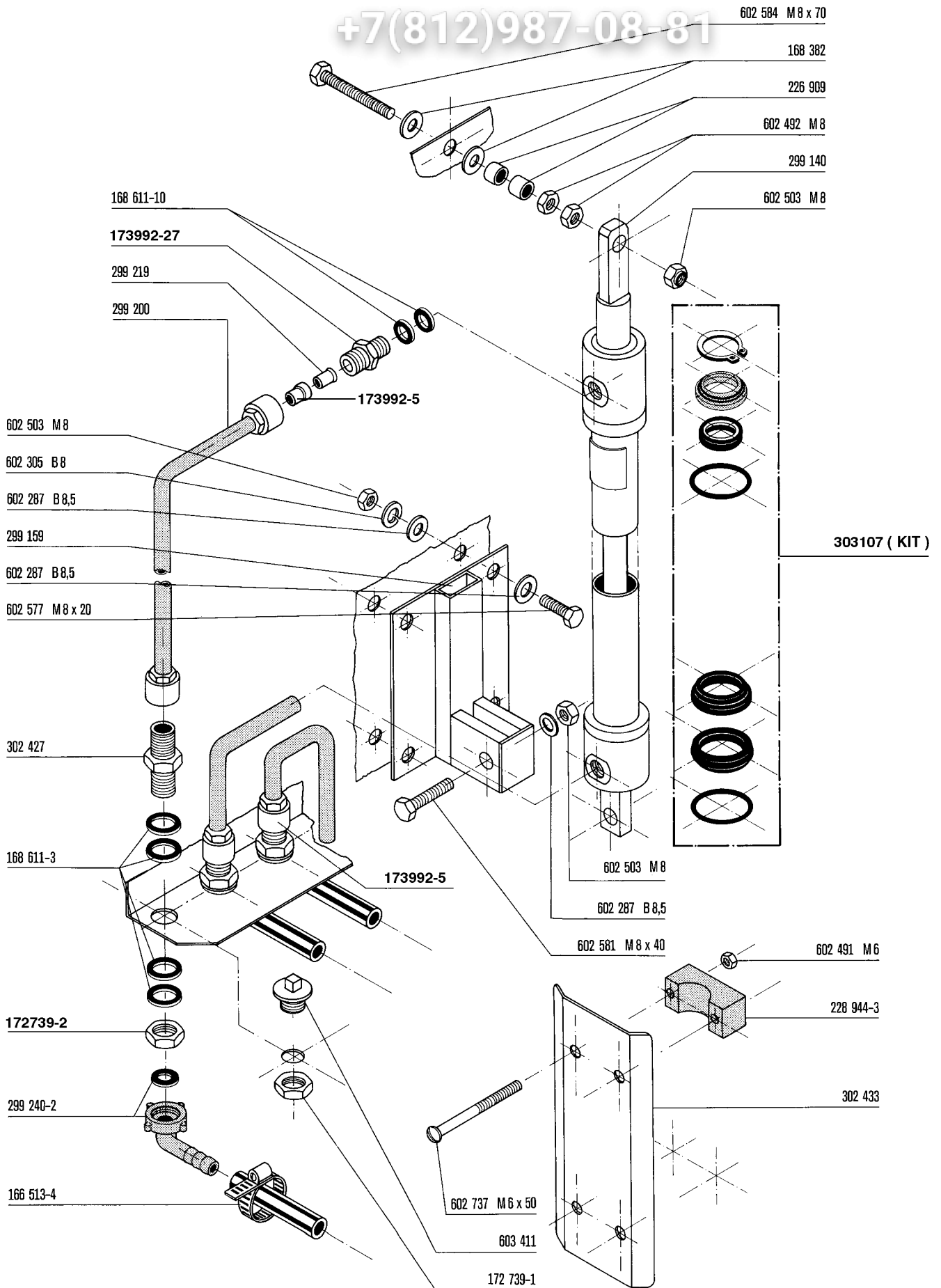

+7(812)987-08-81

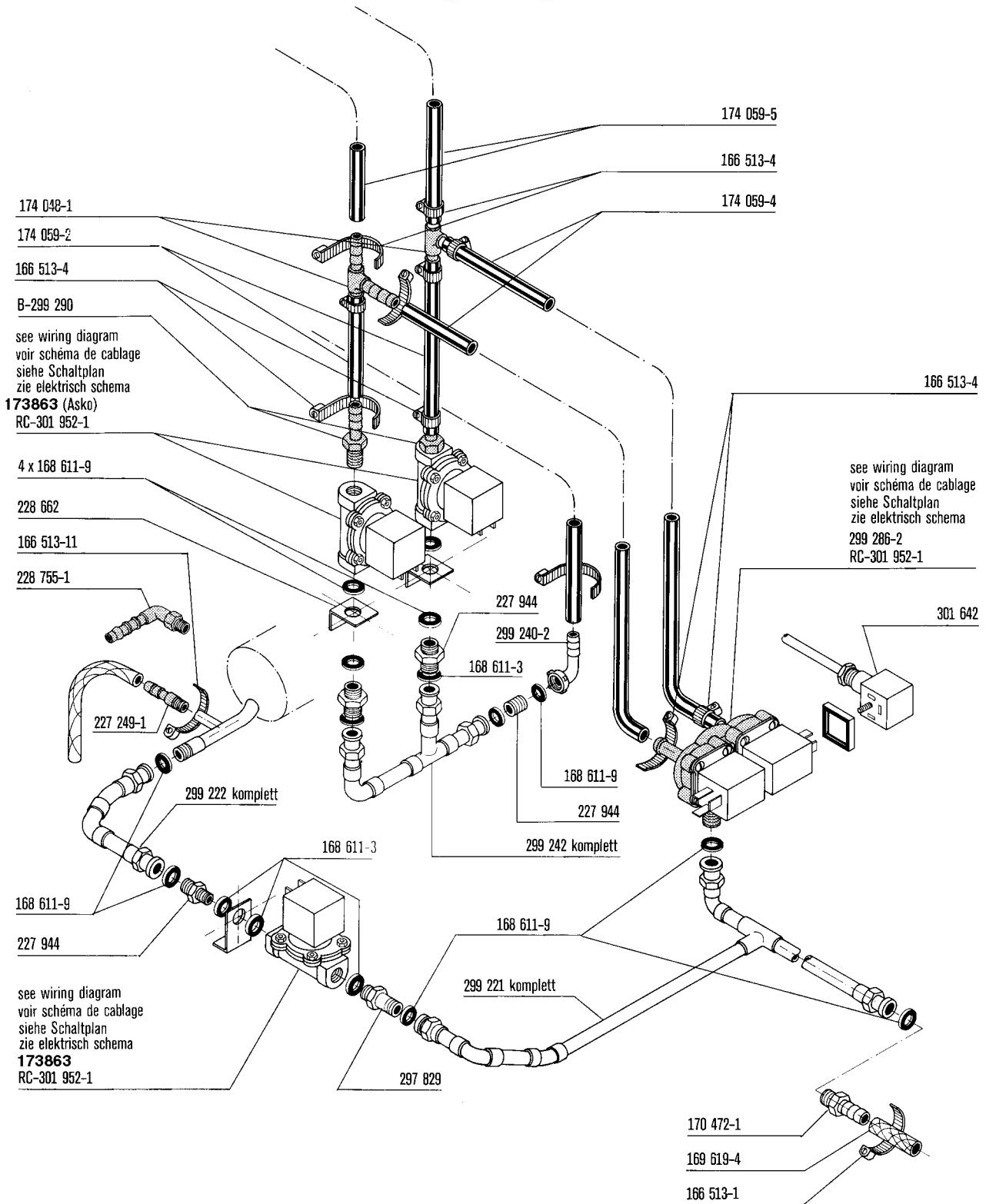

+7(812)987-08-81

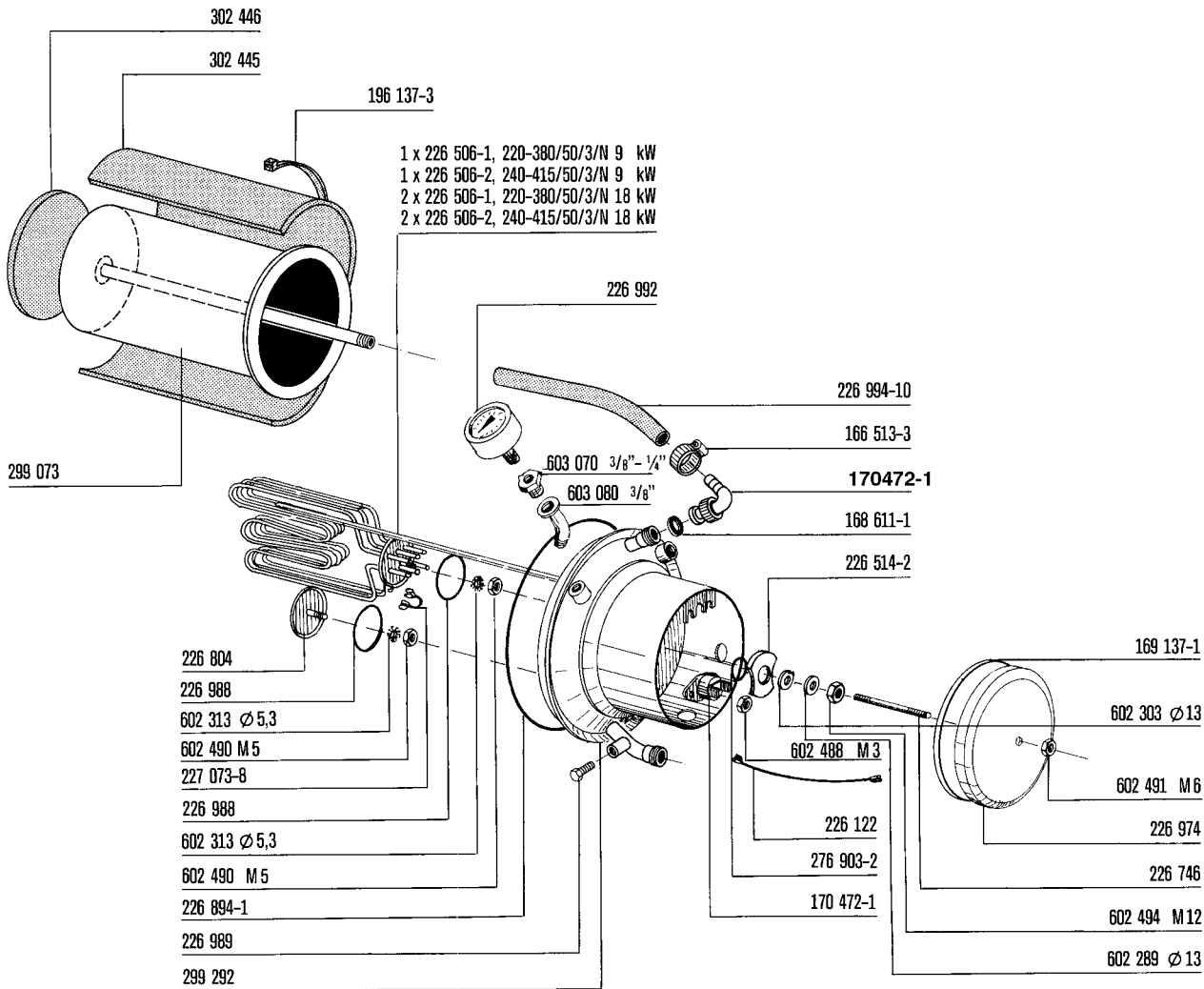

+7(812)987-08-81

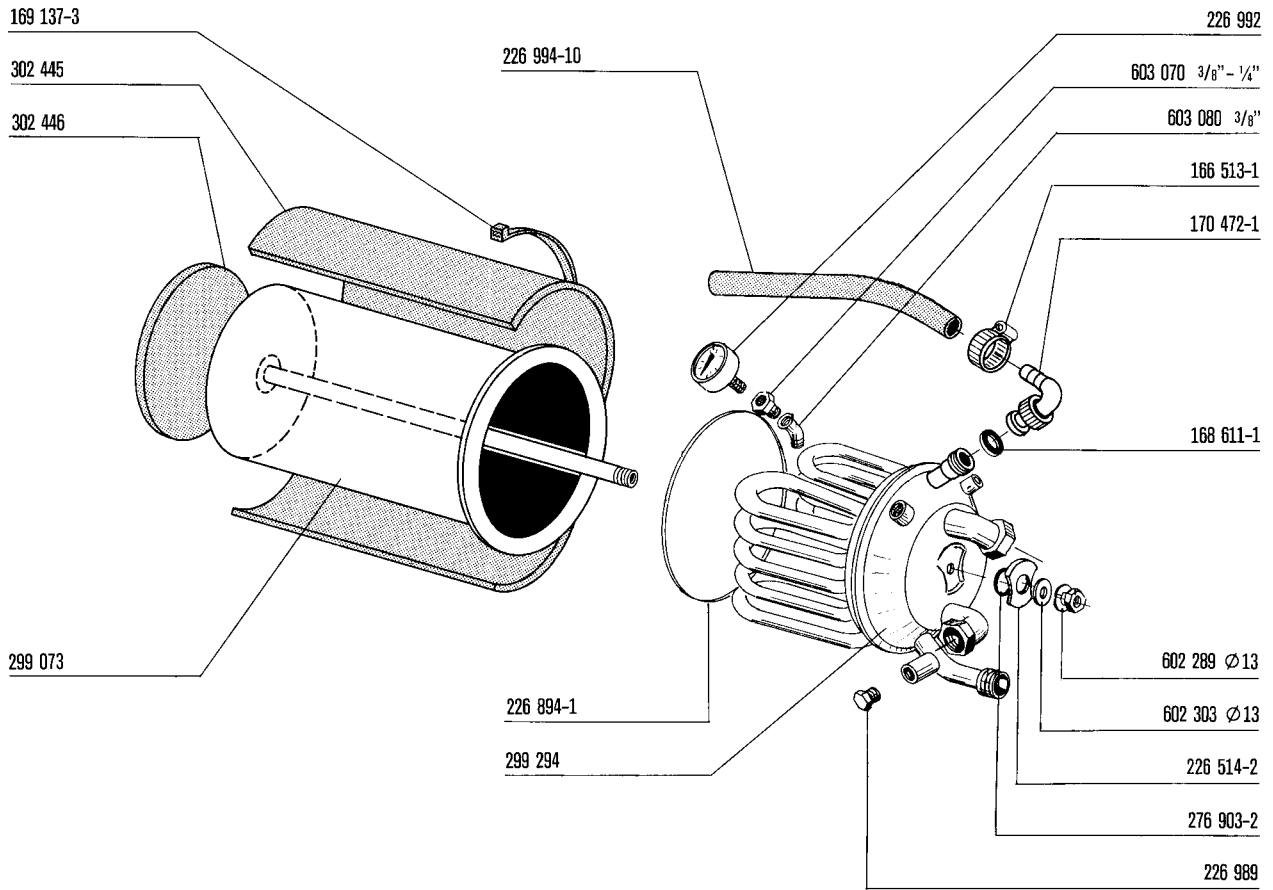

+7(812)987-08-81

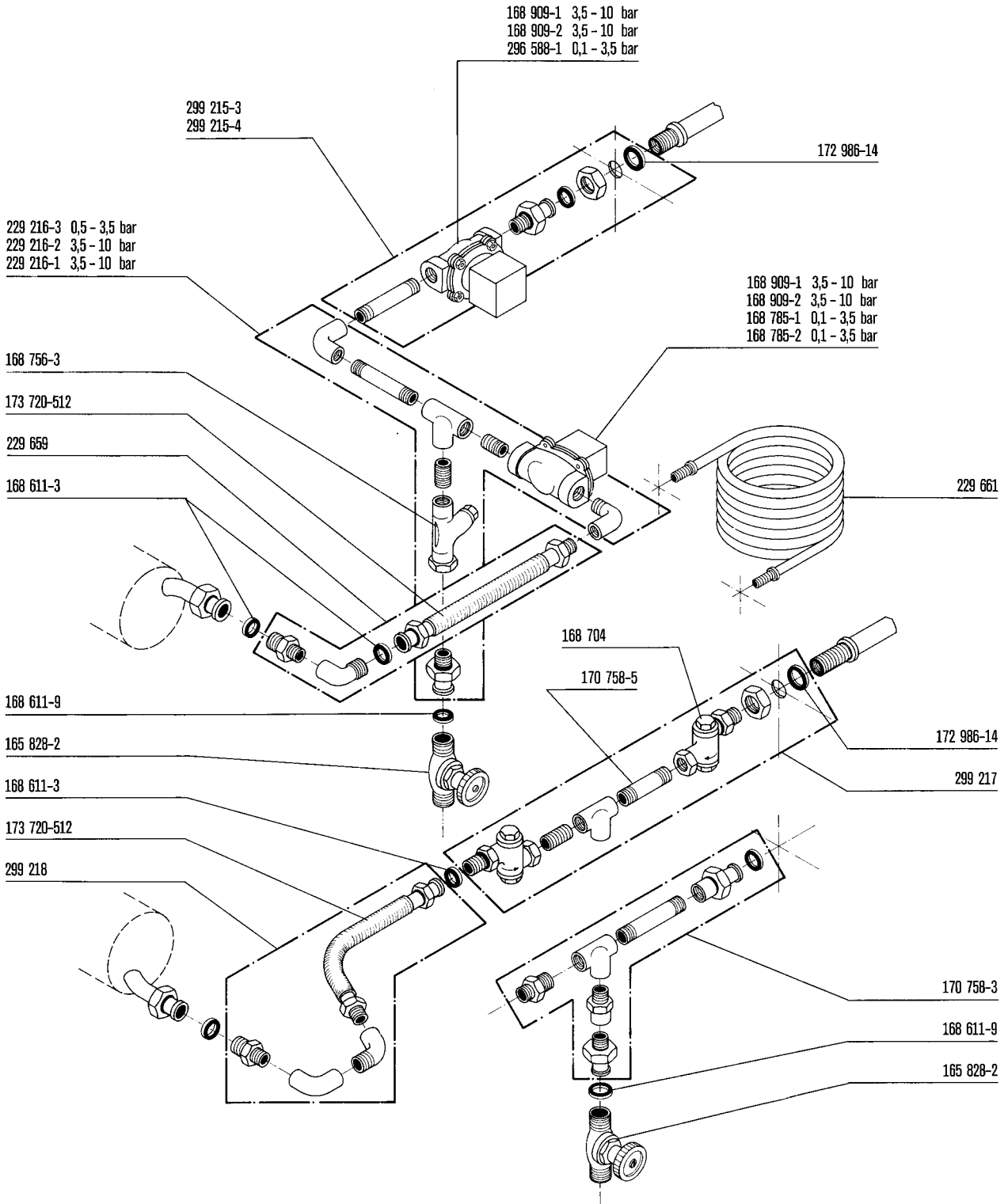

+7(812)387-08-81

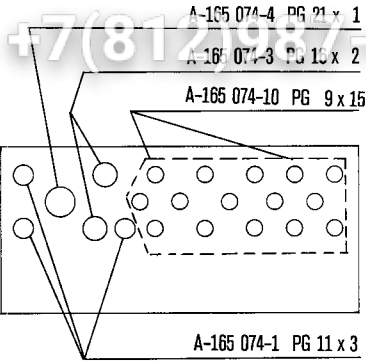

174 930-1

602 689 M 4 x 16

228 708

296979-4

299 187

602 313 A 5,3

602 490 M 5

296 094

302 415

299 227-1
299 227-2

603 375 M 5 x 15

602 313 A 5,3

602 490 M 5

227 073-76

296583-2
COMPLETE WITH EPROM

602 491 M 6

A-166 189

299 188

228 186

602 491 M 6

A-165 074-1
A-165 074-3
A-165 074-4
A-165 074-10

302 409

168 243-1

602 490 M 5

227 073-71

602 286 B 6,4

602 491 M 6

602 286 B 6,4

602 326 A 6,4

602 491 M 6

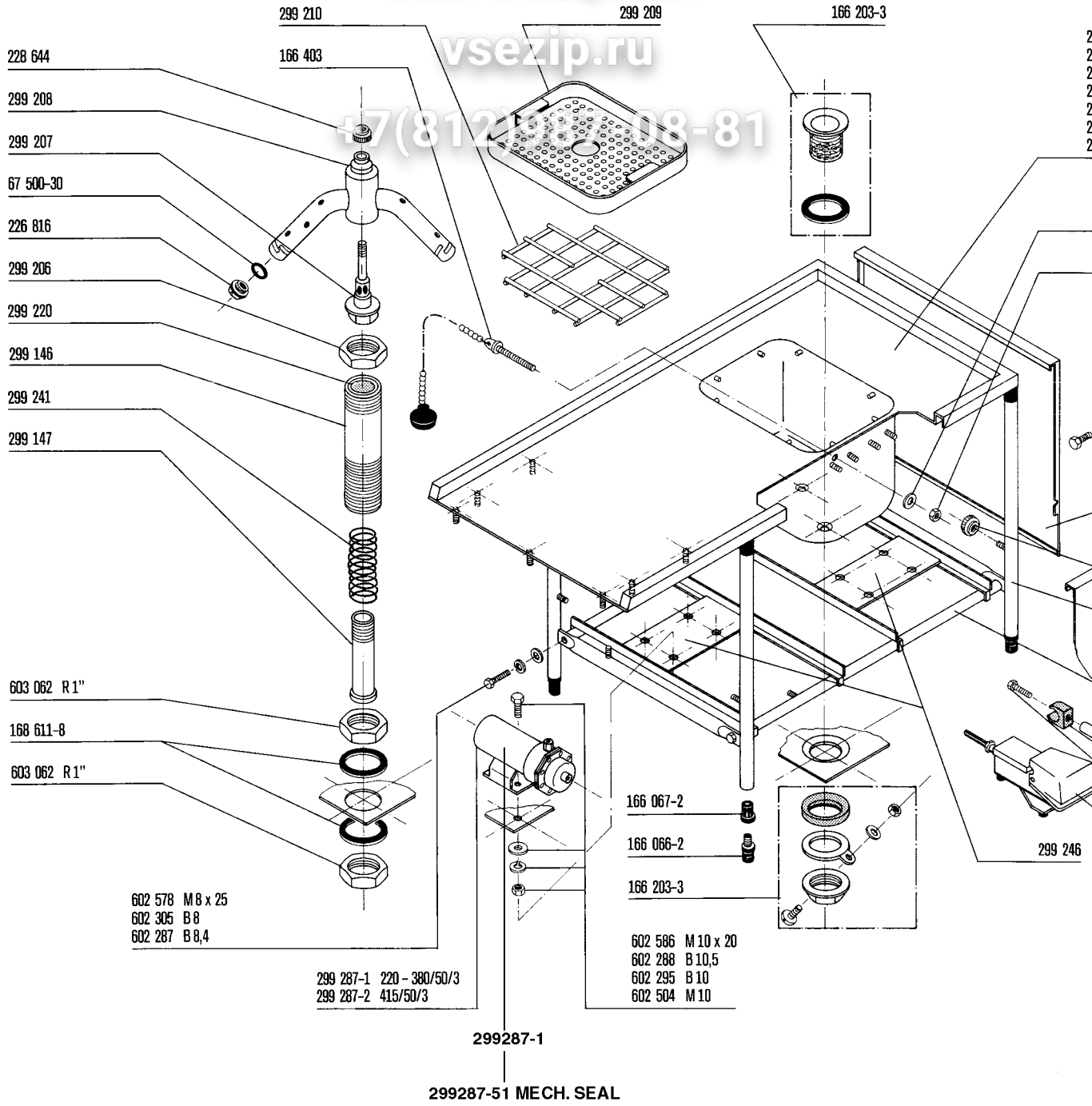

+7(812)987-08-81

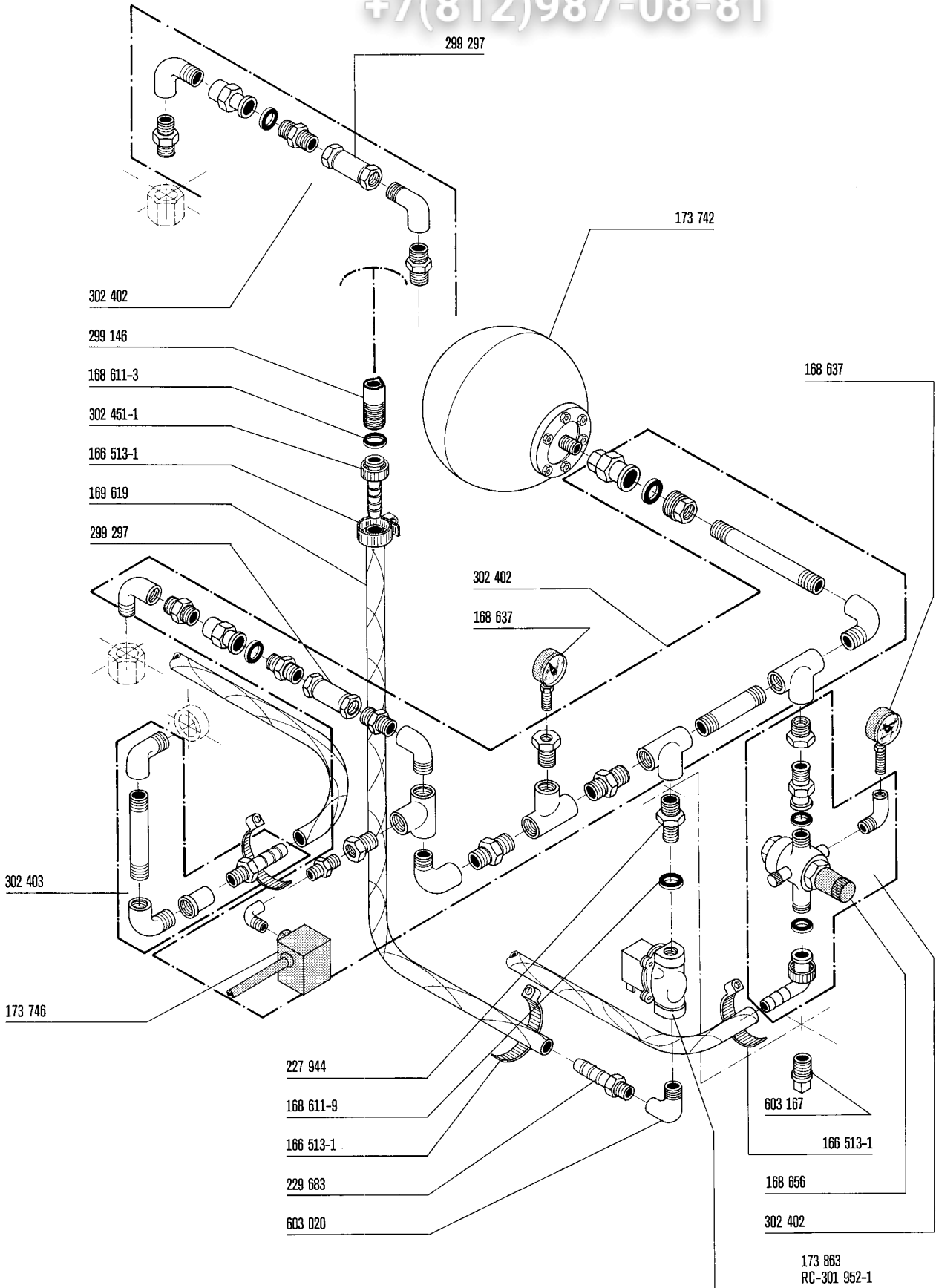

+7(812)987-08-81

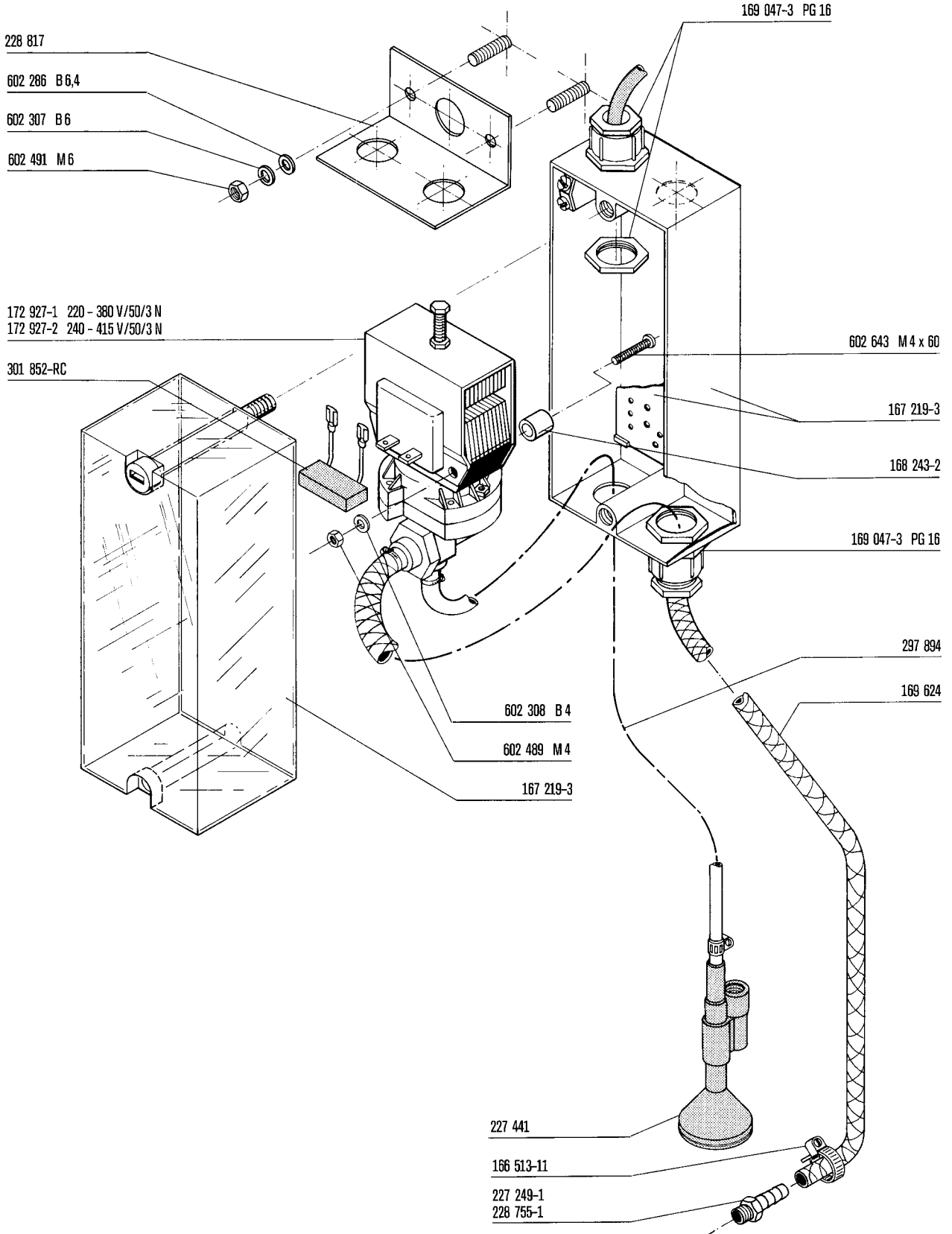

+7(812)987-08-81

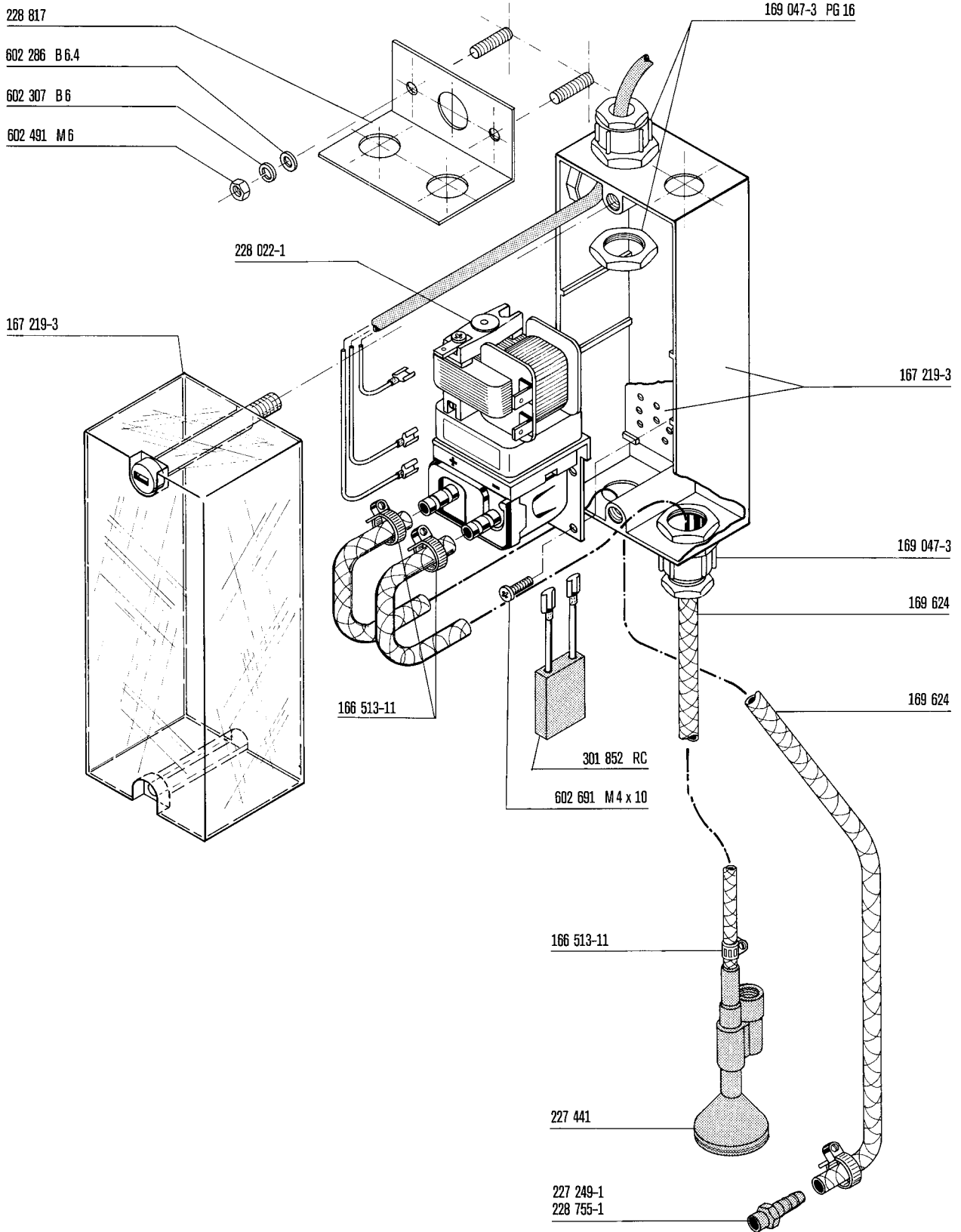

+7(812)987-08-81

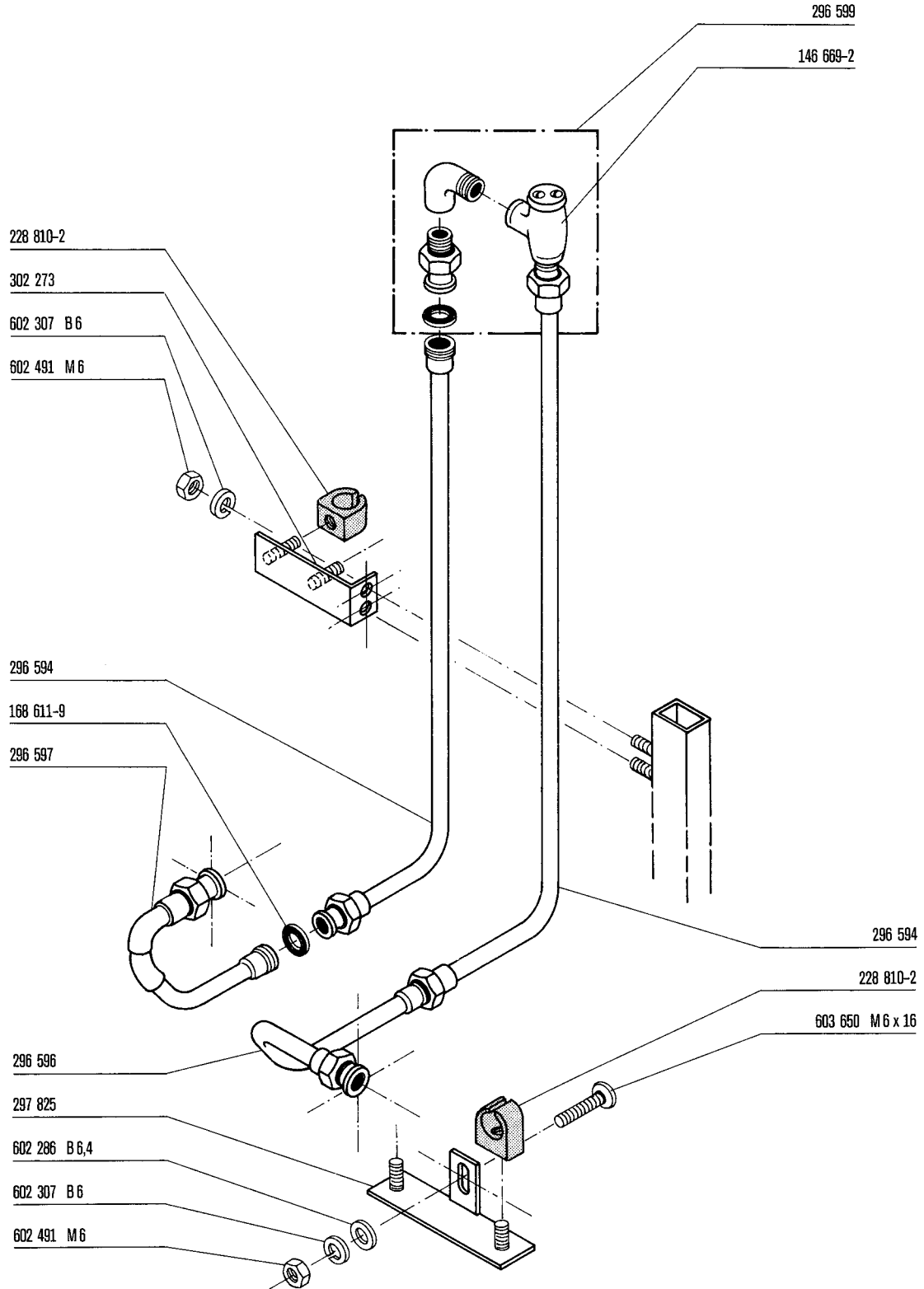

+7(812)987-08-81

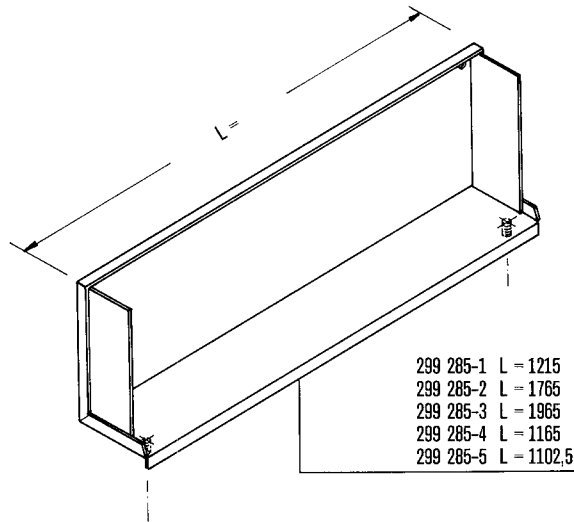

Зип Общепит
vsezip.ru
+7(812)987-08-81

As continued product improvement is a policy of HOBART, specifications are subject to change without notice.

Ce catalogue n'est pas contractuel. HOBART se réserve le droit, et sans préavis, d'apporter toutes modifications ou améliorations à ses matériels.

HOBART behält sich das Recht vor, an allen Produkten technische Änderungen und Verbesserungen ohne Ankündigung vorzunehmen.

Voortdurende produktverbetering vormt een wezenlijk onderdeel van het beleid van HOBART. Specificaties kunnen zonder kennisgeving gewijzigd worden.