

+7(812)987-08-81

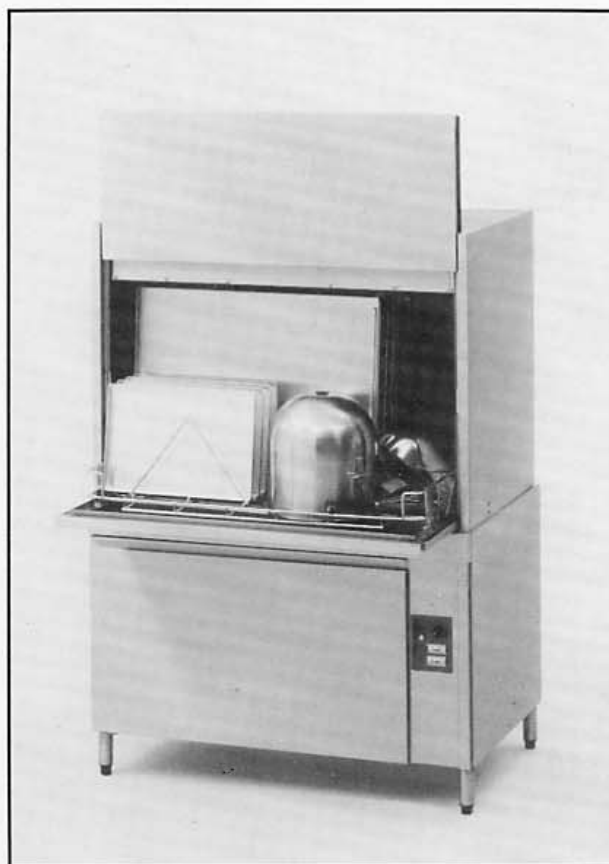

UW-125 / UW-205

Spare Parts
Pièces Détachées
Ersatzteile
Onderdelen

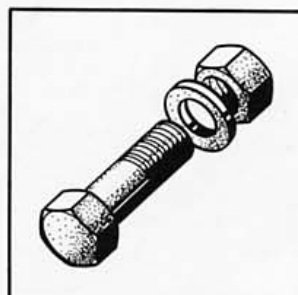

vsezip.ru

+7(812)987-08-81

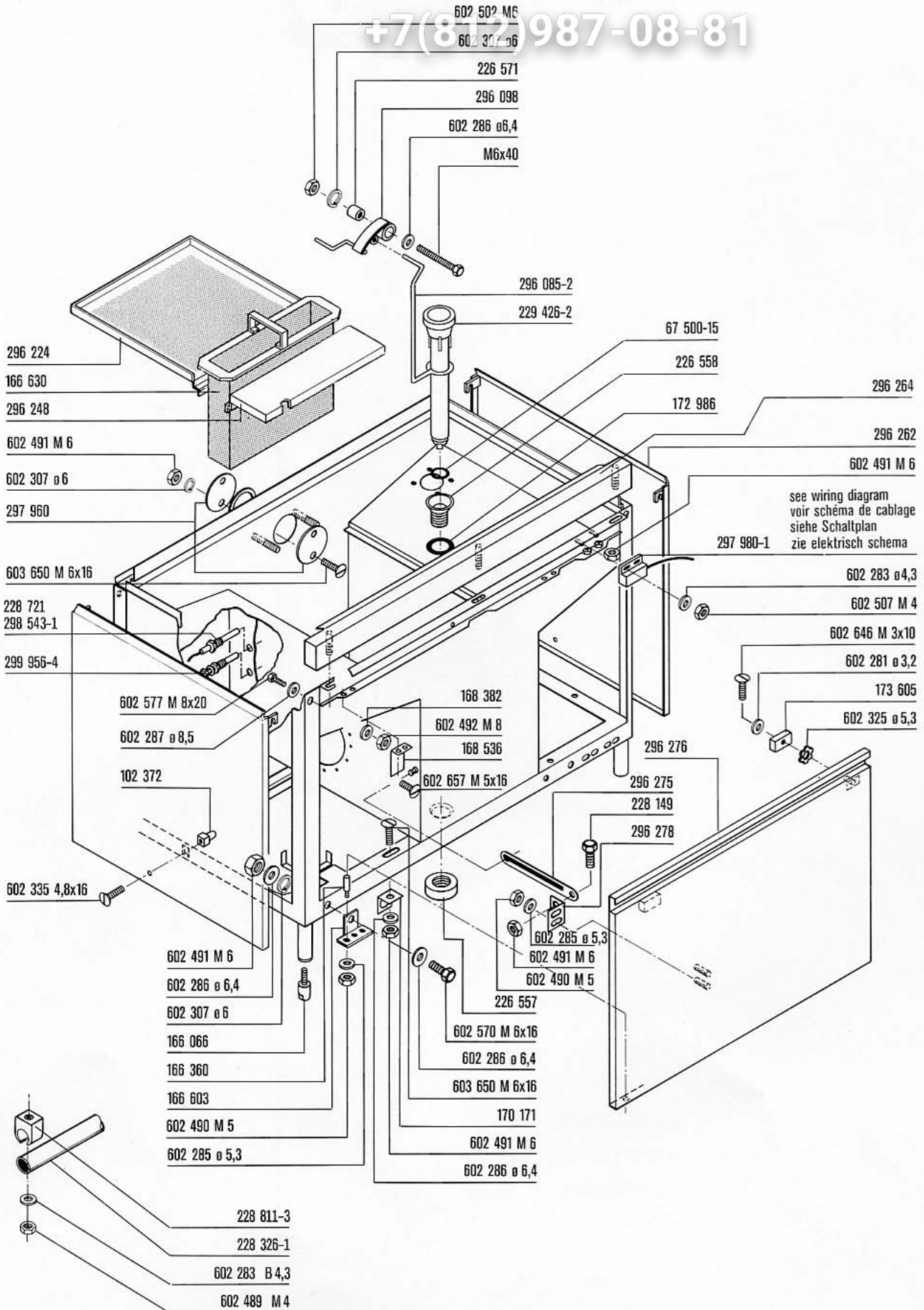

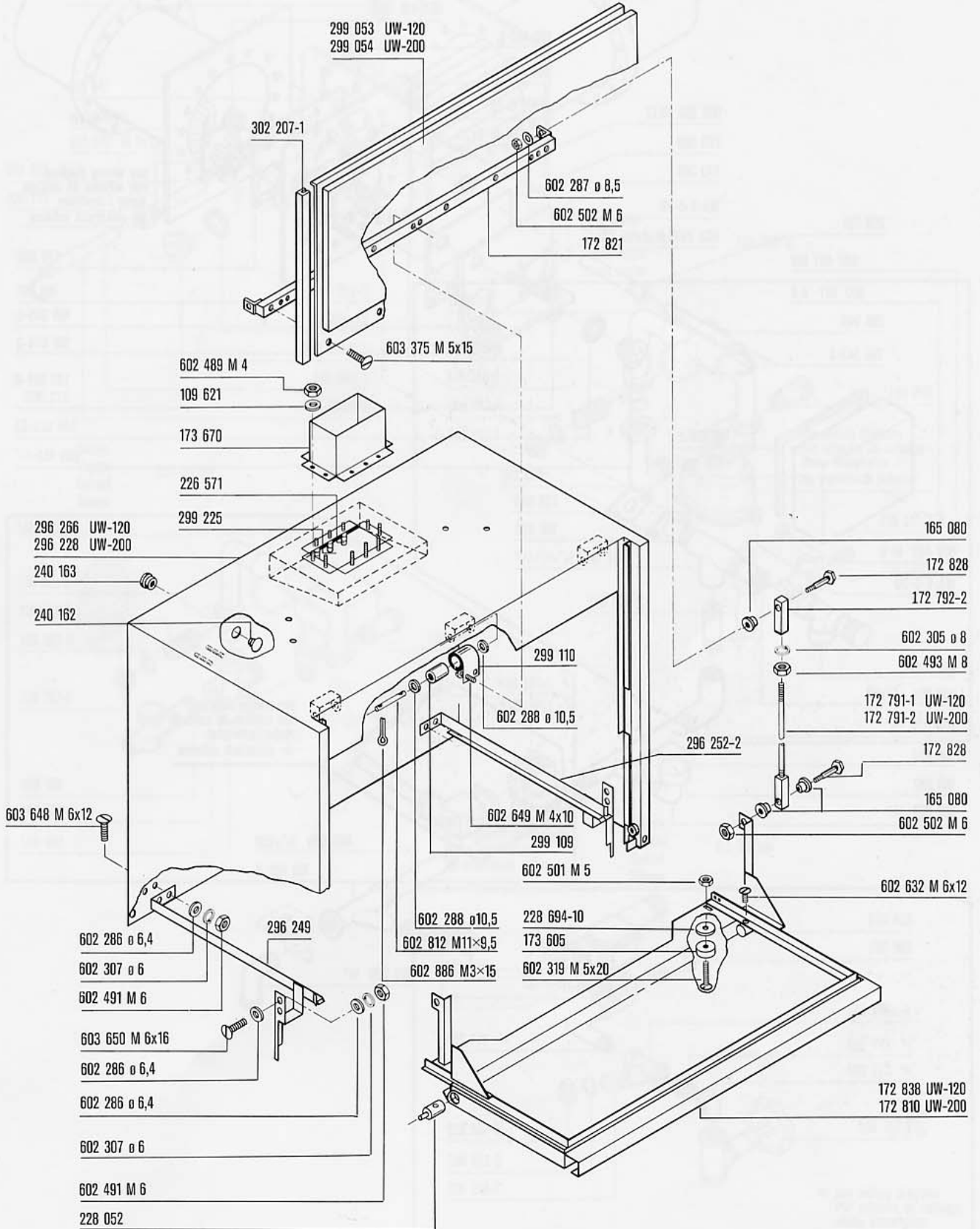

vsezip.ru

+7(812)987-0881

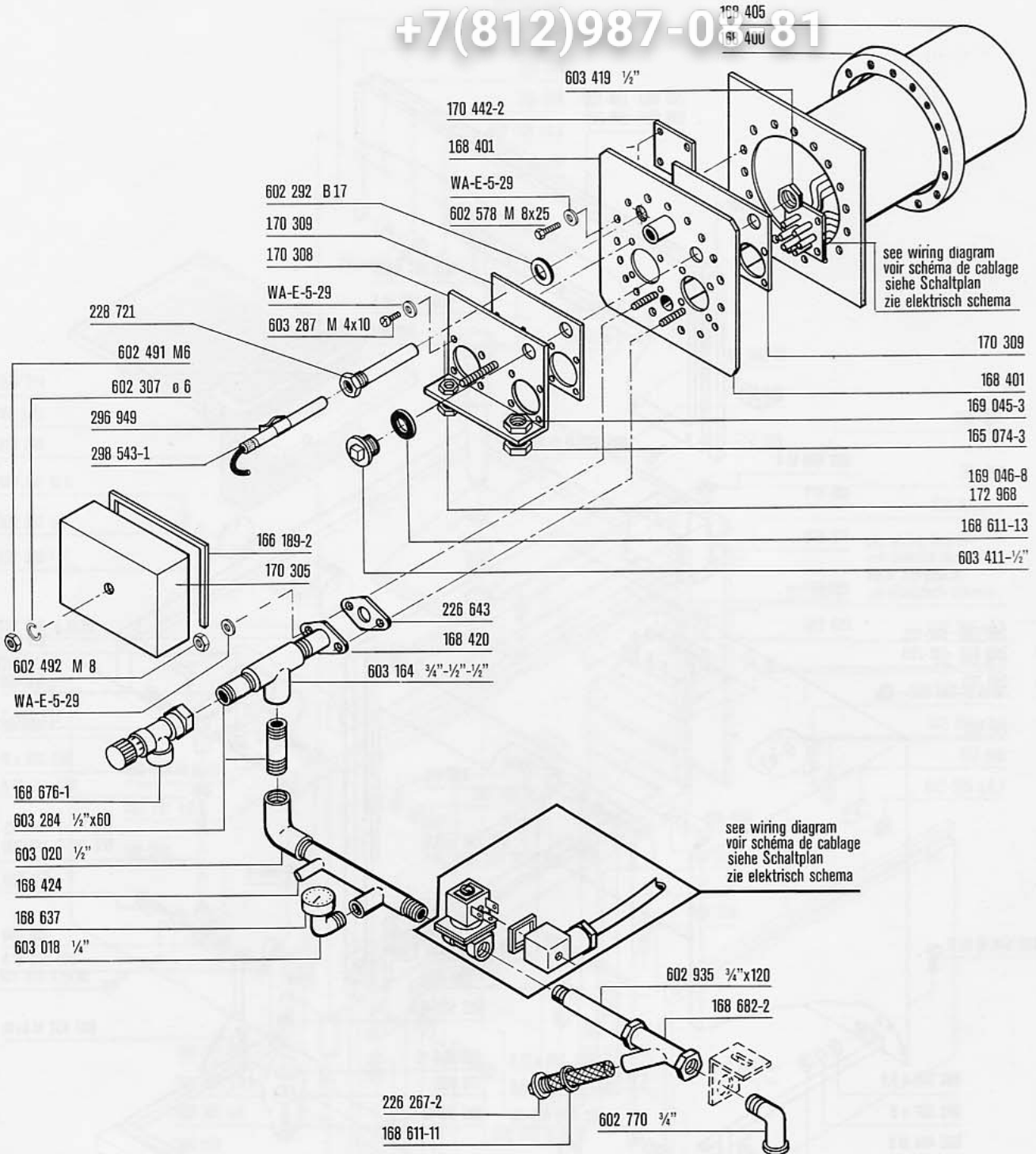

vsezip.ru
 +7(812)987-08-81

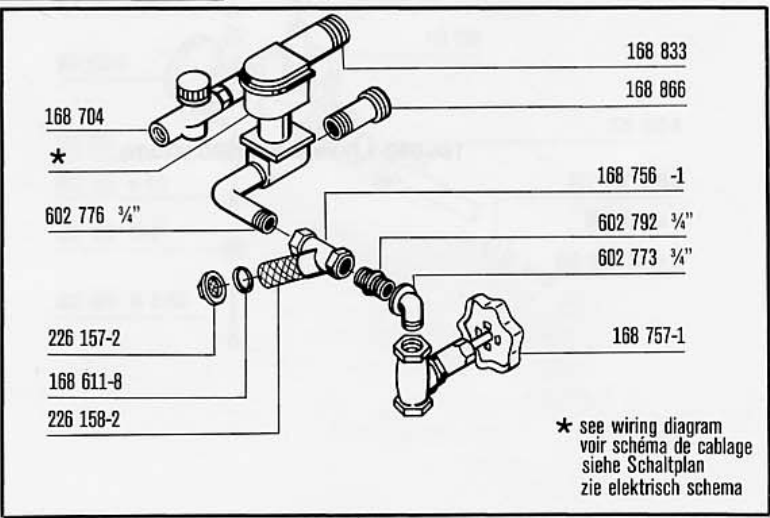
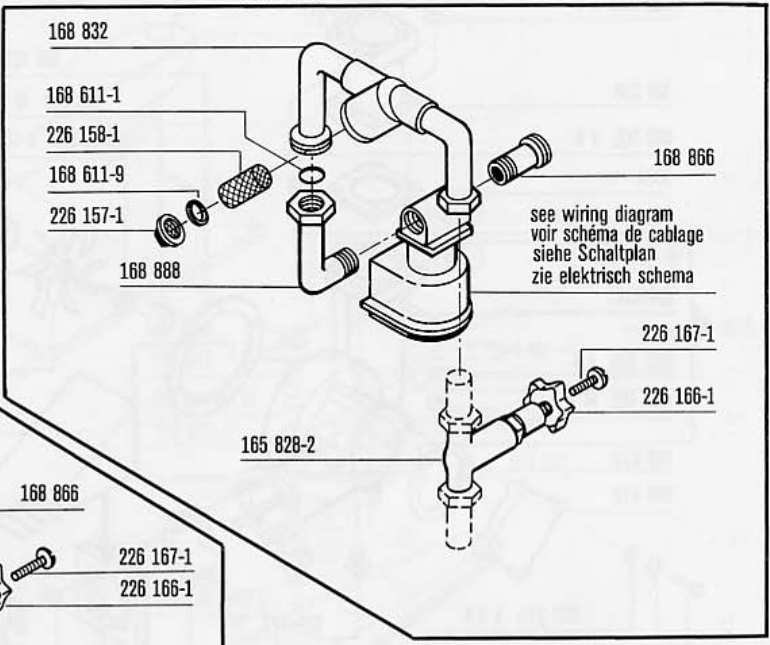
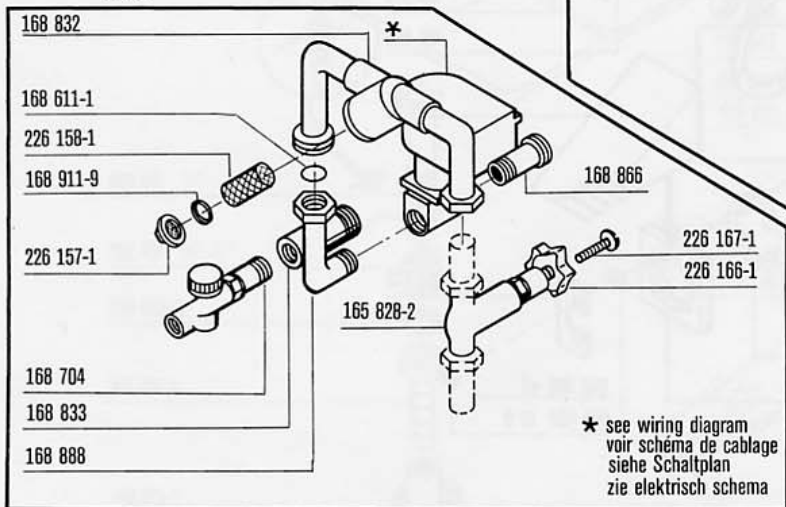
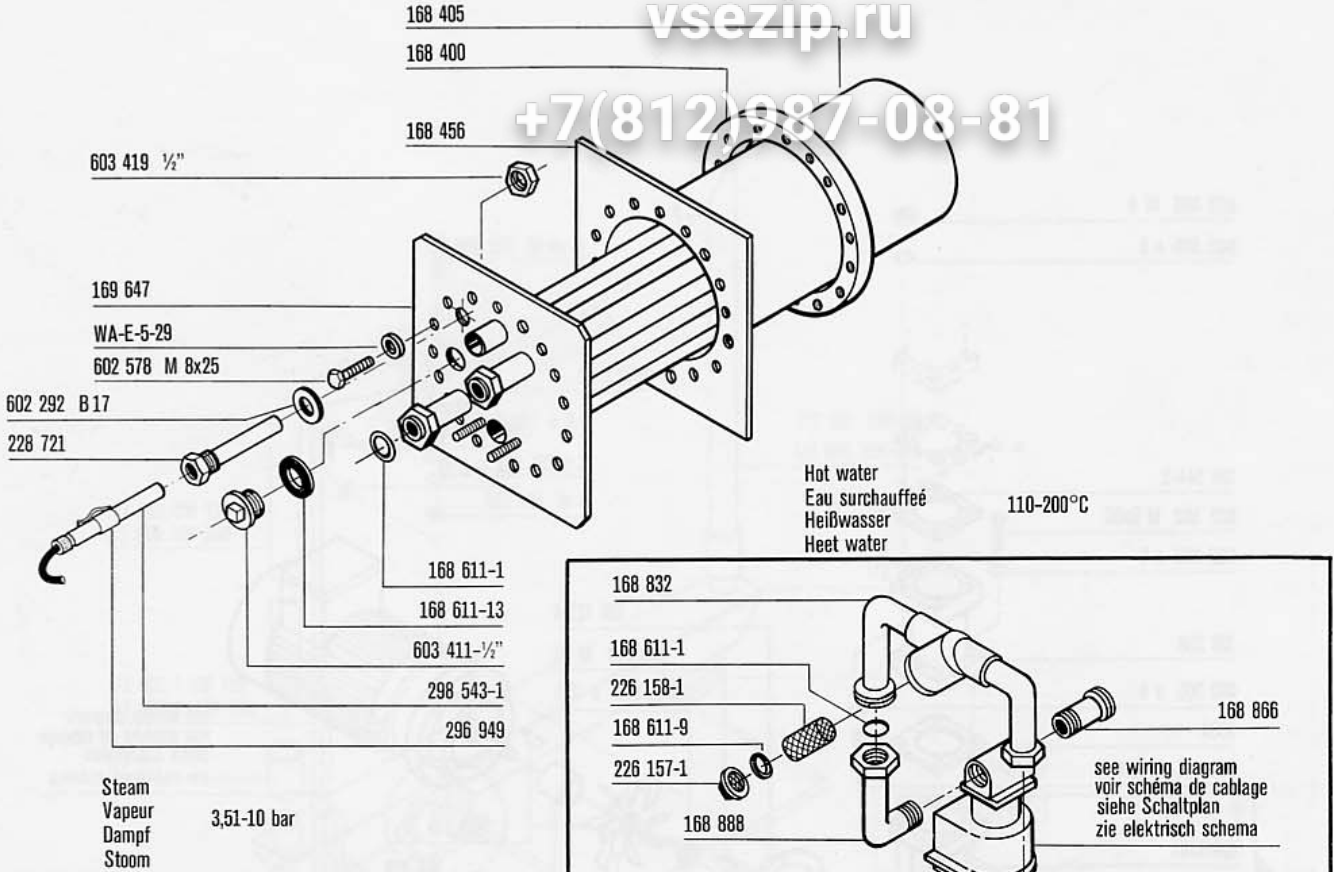

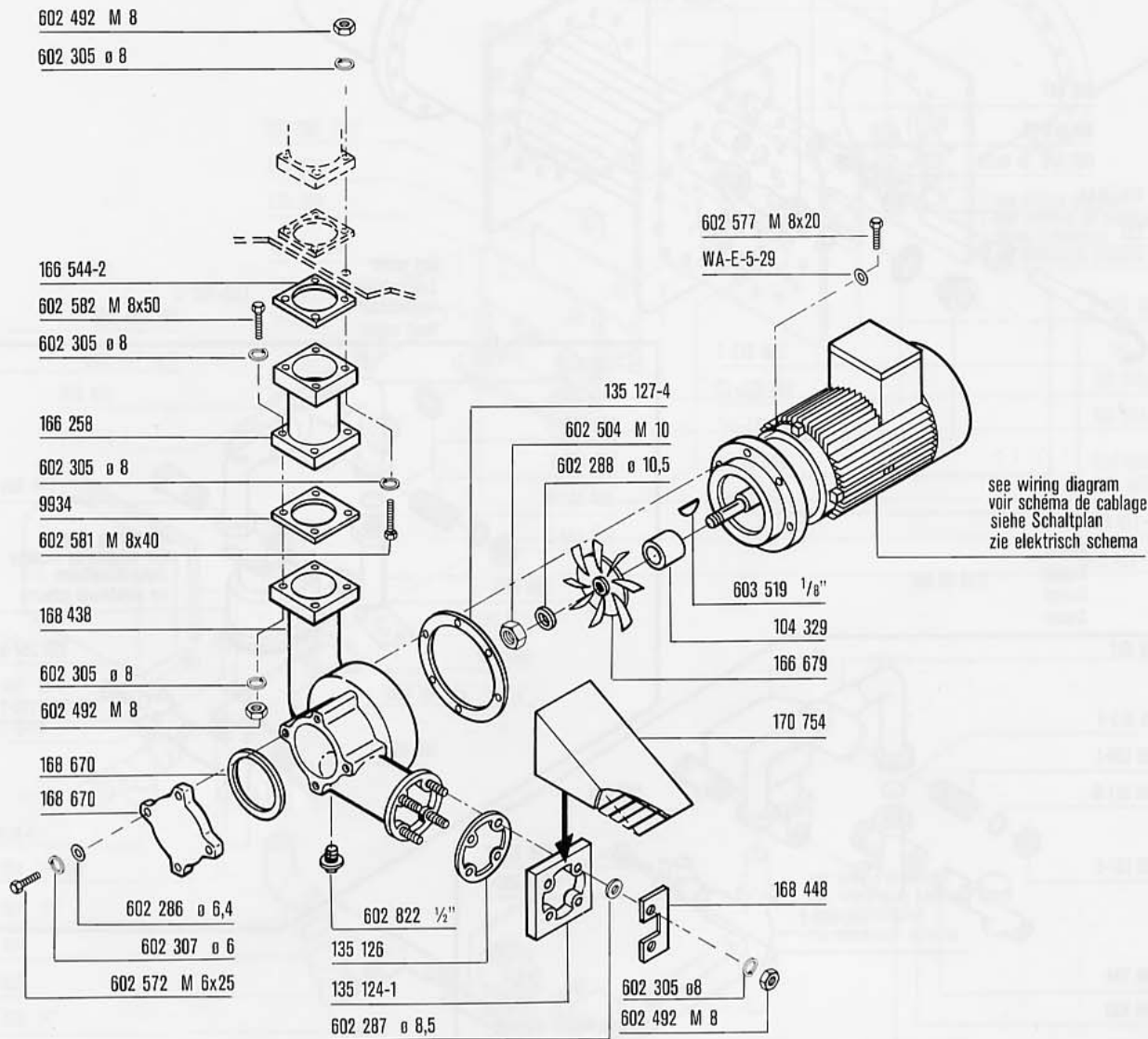

166 690-1 Pumpe kpl.(380/50/3/N)

всёzip.ru
 +7(812)987-08-81

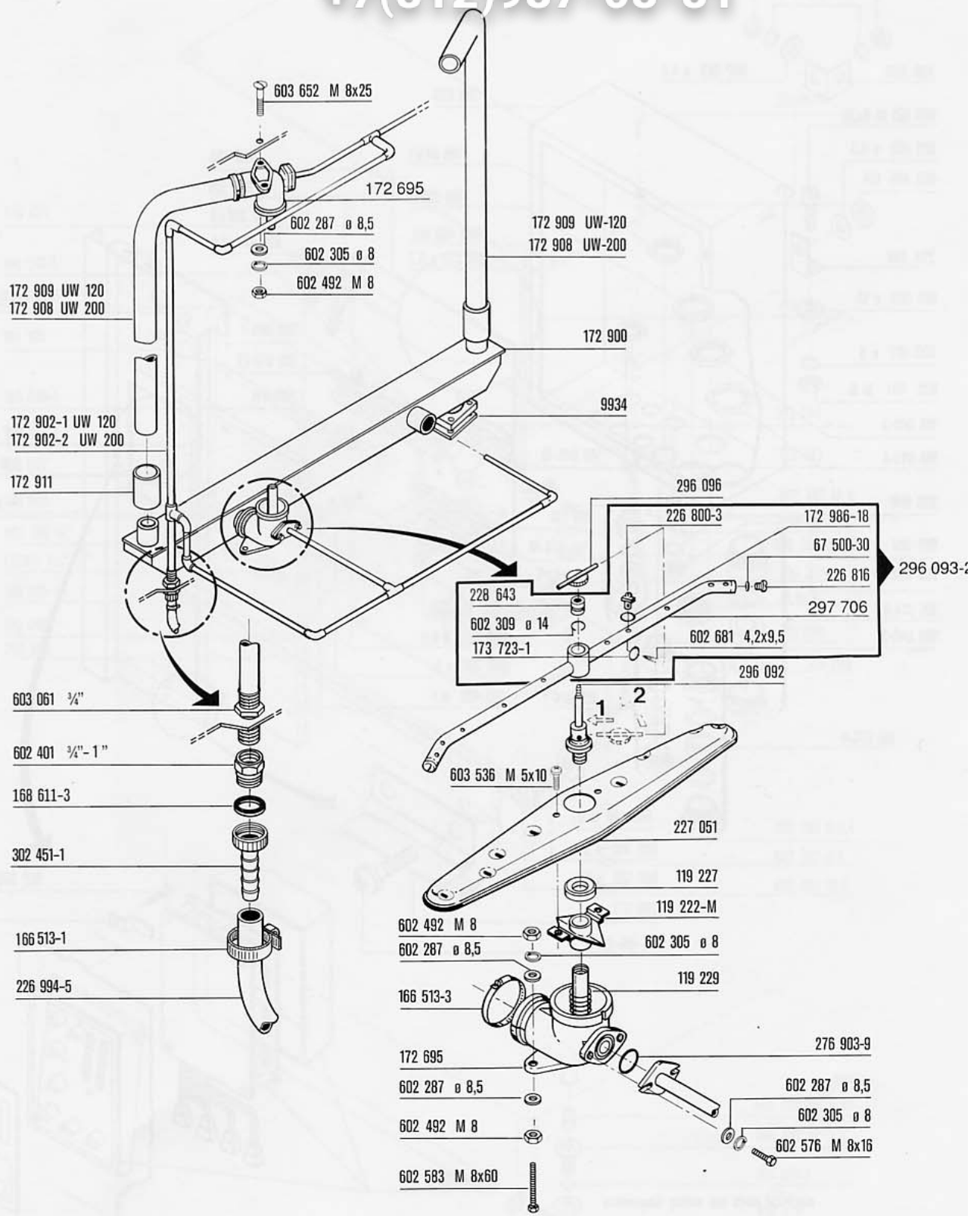

vsezip.ru

+7(812)987-08-81

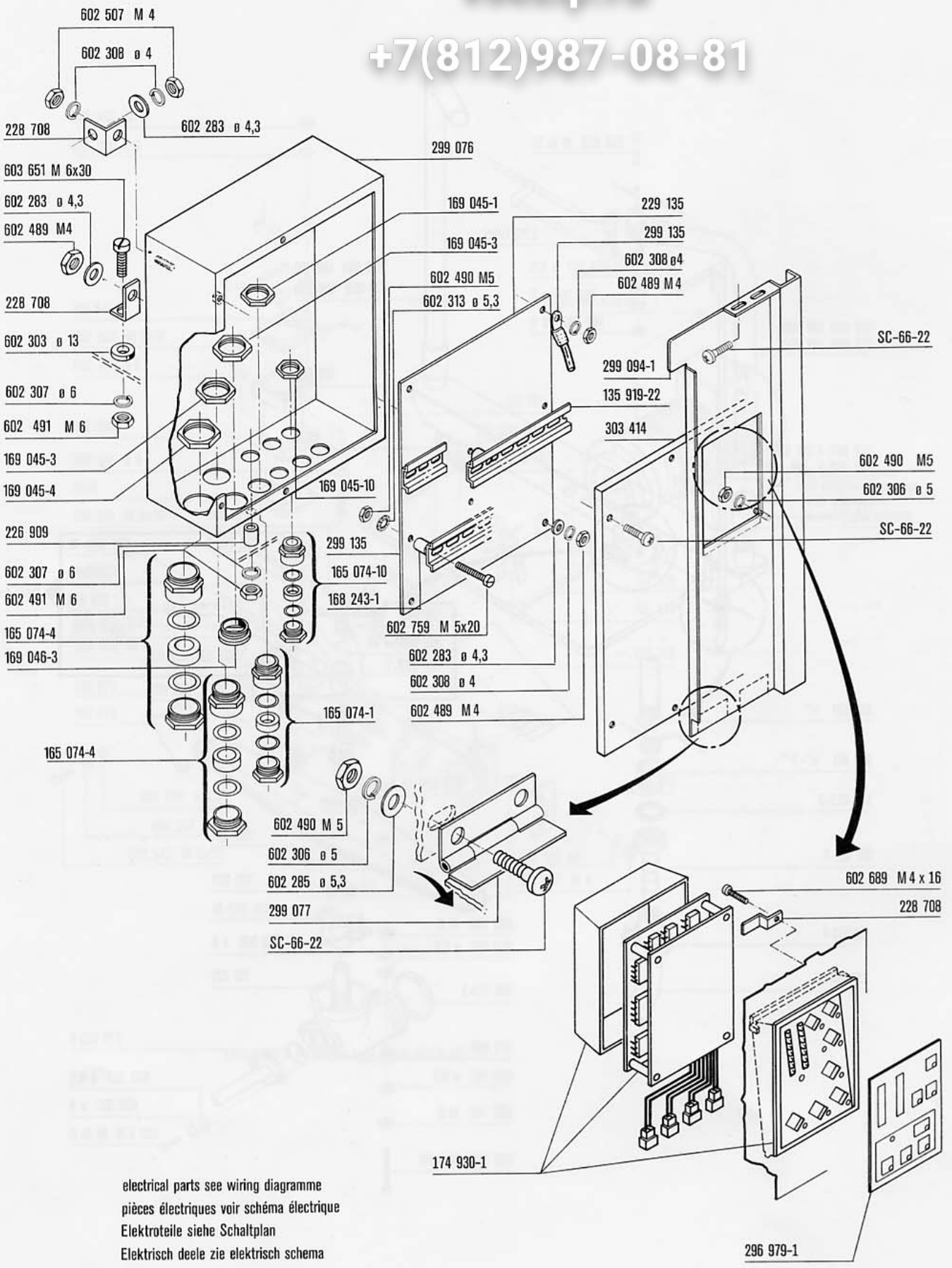

electrical parts see wiring diagramme
pièces électriques voir schéma électrique
Elektroteile siehe Schaltplan
Elektrisch deele zie elektrisch schema

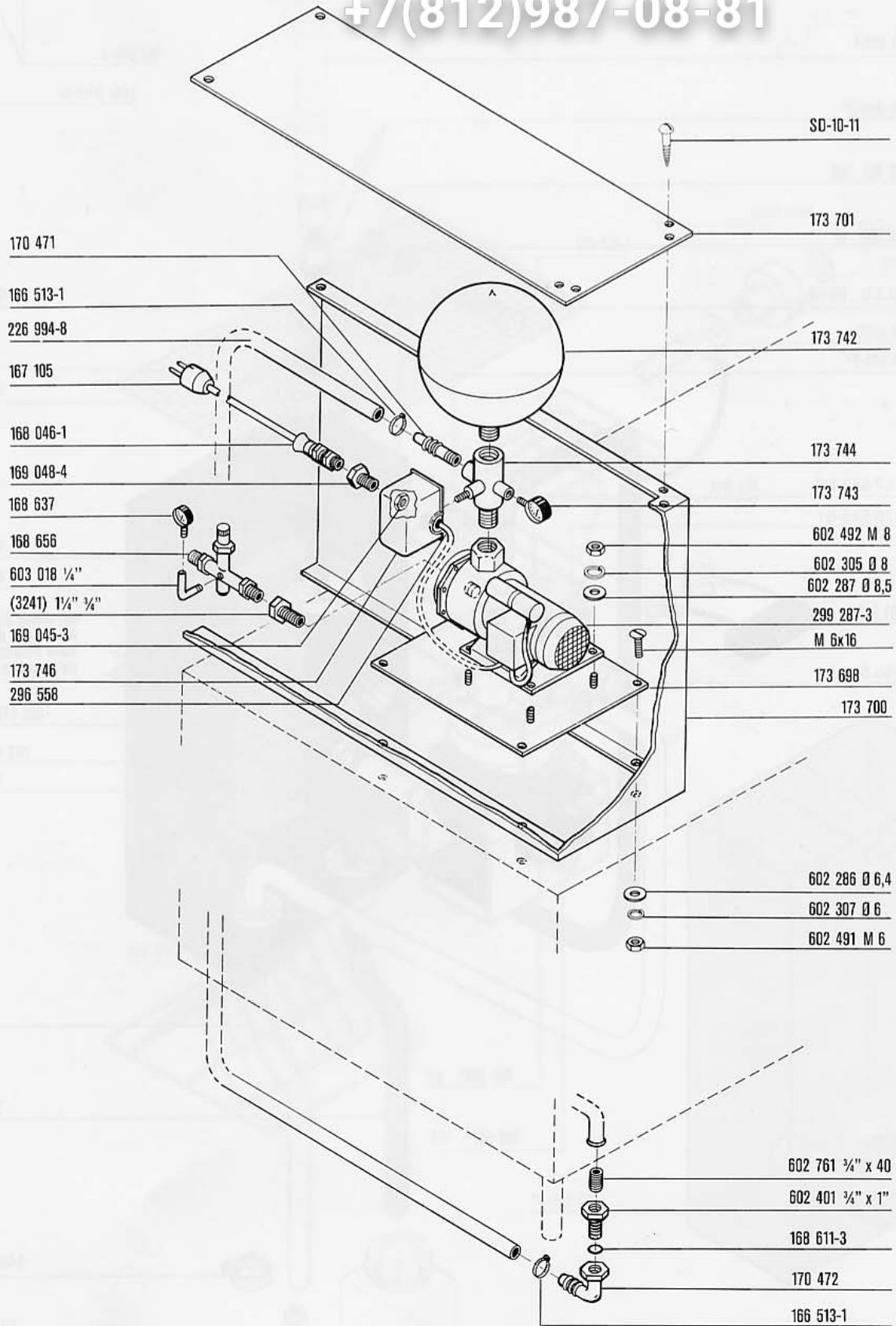

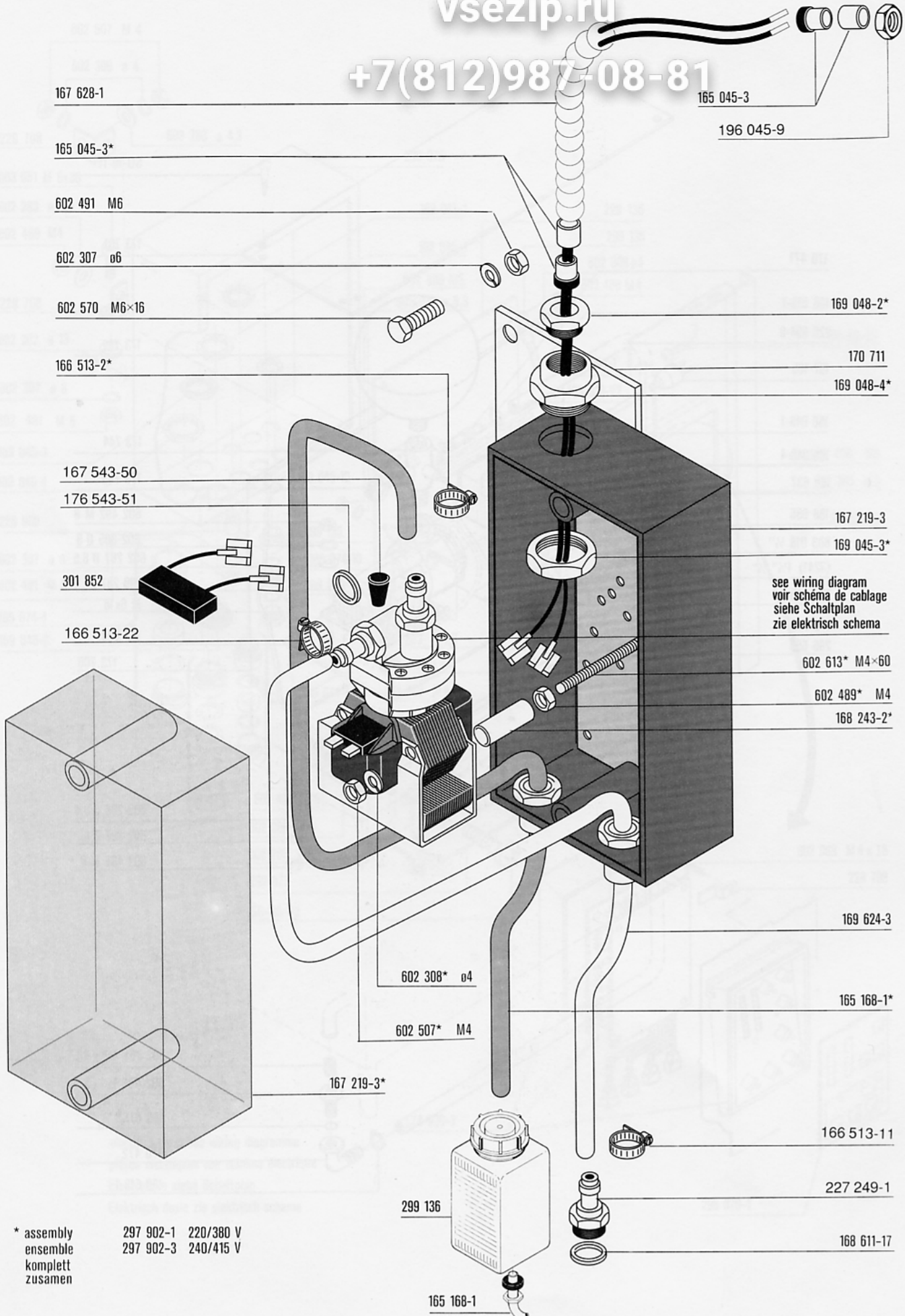

* assembly
 ensemble
 komplett
 zusammen

297 902-1 220/380 V
 297 902-3 240/415 V

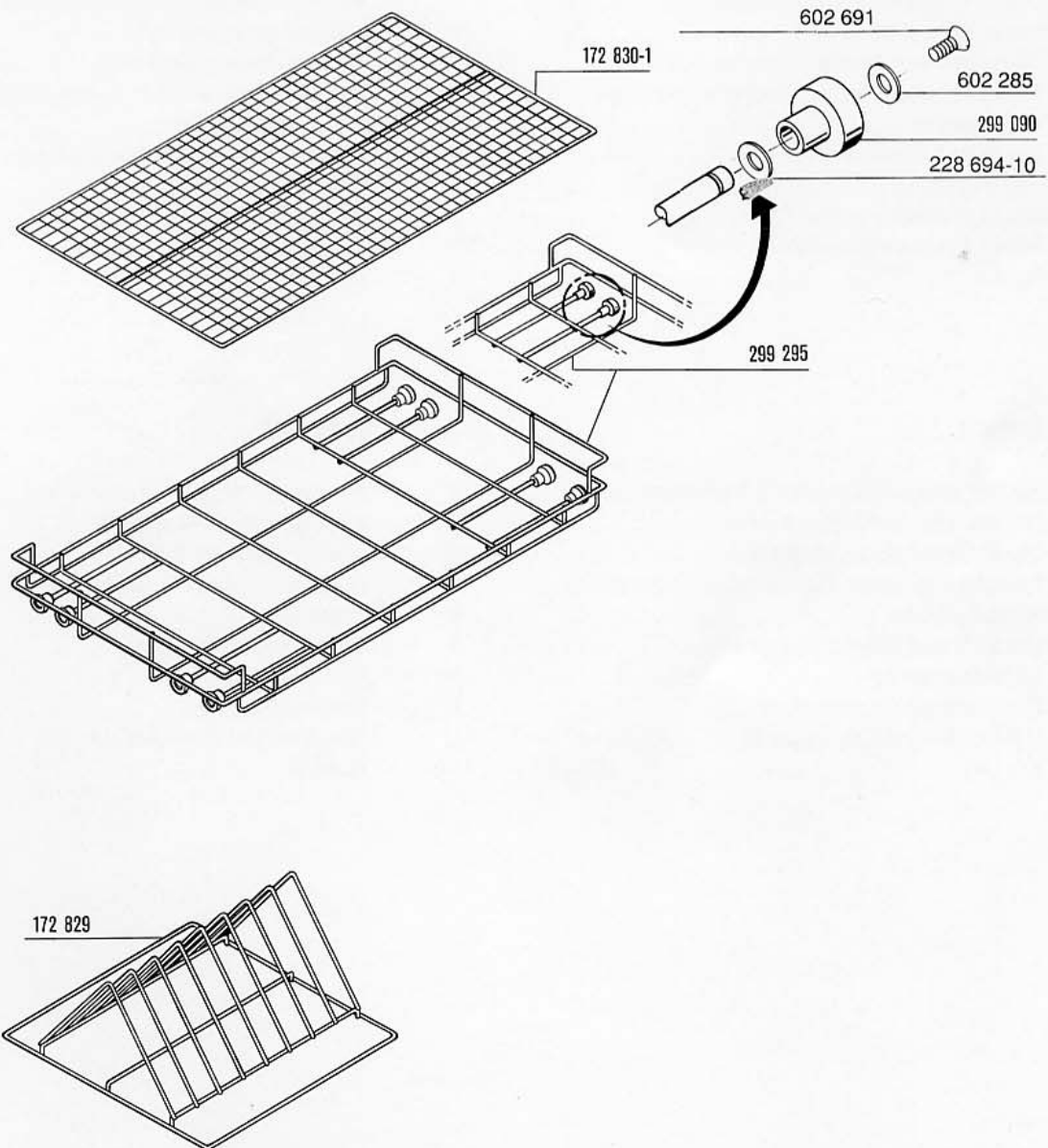

Зип Ощепит

vsezip.ru

+7(812)987-08-81

Contents

| | |
|--|----|
| Drain, strainers, frame and panels | 2 |
| Hood, door and track | 3 |
| Rinse booster heater, electric | 4 |
| Rinse booster heater, steam or hot water | 5 |
| Wash pump | 6 |
| Wash and rinse system | 7 |
| Control box | 8 |
| Rinse pressure pump | 9 |
| Rinse agent dispenser | 10 |
| Racks | 11 |

Sommaire

| | |
|---|----|
| Vidange, filtres, chassis et panneaux | 2 |
| Caisson, porte et rails | 3 |
| Surchauffeur, électrique | 4 |
| Surchauffeur, vapeur ou eau surchauffée | 5 |
| Pompe de lavage | 6 |
| Système de lavage et de rinçage | 7 |
| Coffret électrique | 8 |
| Pompe élévatrice de pression | 9 |
| Doseur de produit de rinçage | 10 |
| Paniers | 11 |

Inhalt

| | |
|--|----|
| Ablauf, Siebe, Gestell und Verkleidungen | 2 |
| Haube, Tür und Laufschiene | 3 |
| Durchlauferhitzer, elektrisch | 4 |
| Durchlauferhitzer, Dampf oder Heißwasser | 5 |
| Waschpumpe | 6 |
| Wasch- und Klarspülsystem | 7 |
| Schaltkasten | 8 |
| Drucksteigerungspumpe | 9 |
| Klarspülmittel-Dosiergerät | 10 |
| Körbe | 11 |

Inhoud

| | |
|--------------------------------------|----|
| Afvoer, zeven, tank en panelen | 2 |
| Kap, deur en rekkenrails | 3 |
| Booster, elektrisch | 4 |
| Booster, stoom of heet water | 5 |
| Waspomp | 6 |
| Was en spoelsysteem | 7 |
| Schakelkast | 8 |
| Spoeldrukomp | 9 |
| Spoelmiddel-doseerapparaat | 10 |
| Rekken | 11 |

As continued product improvement is a policy of HOBART, specifications are subject to change without notice.

Ce catalogue n'est pas contractuel. HOBART se réserve le droit, et sans préavis, d'apporter toutes modifications ou améliorations à ses matériels.

HOBART behält sich das Recht vor, an allen Produkten technische Änderungen und Verbesserungen ohne Ankündigung vorzunehmen.

Voortdurende produktverbetering vormt een wezenlijk onderdeel van het beleid van HOBART. Specificaties kunnen zonder kennisgeving gewijzigd worden.