

Зип Общепит

vsezip.ru

НОВАРТ +7(812)987-08-81



UW120

UW200

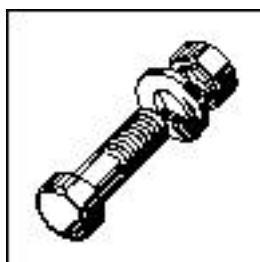

Spare Parts

+7(812)987-08-81

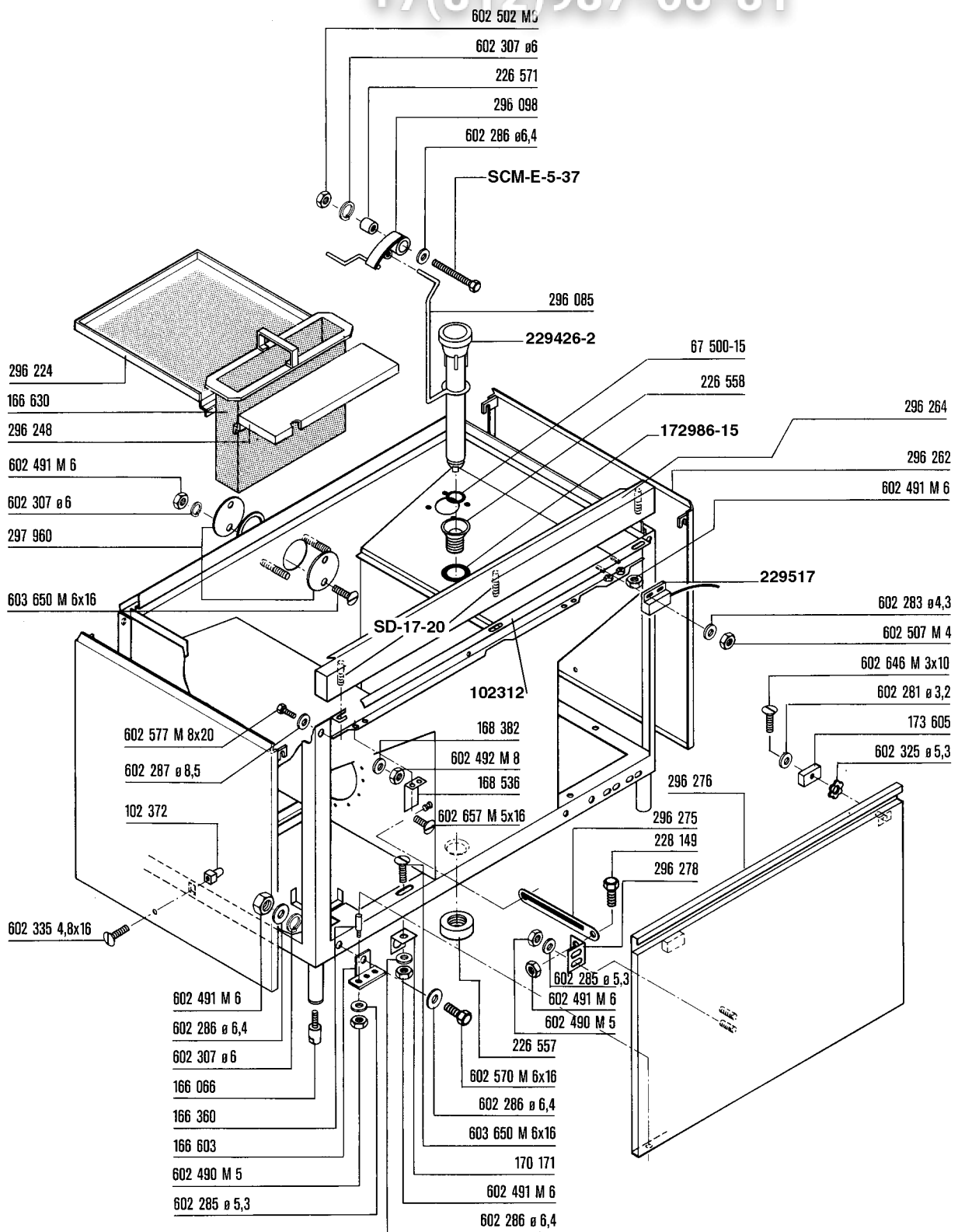

+7(812)987-08-81

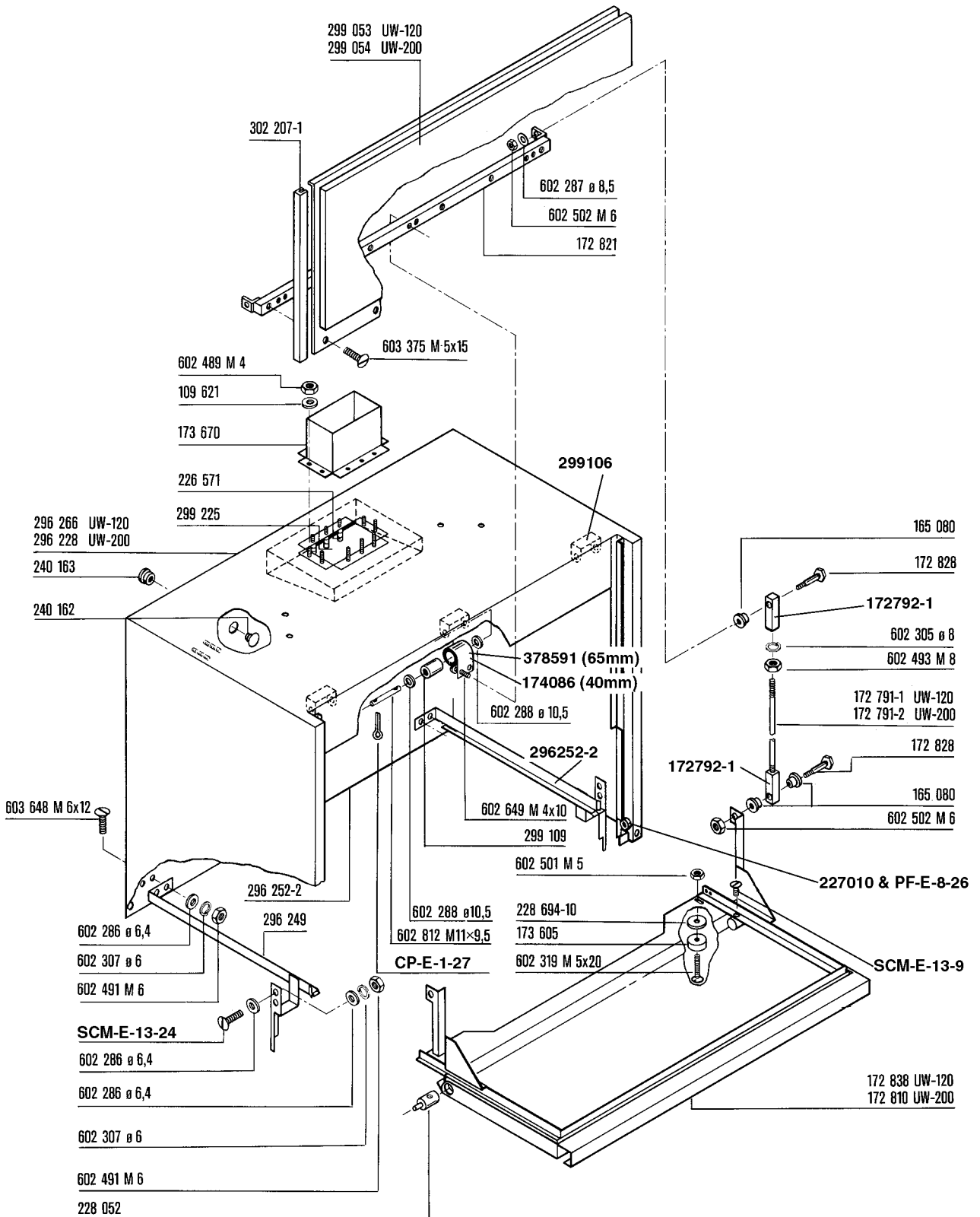

+7(812)987-08-81

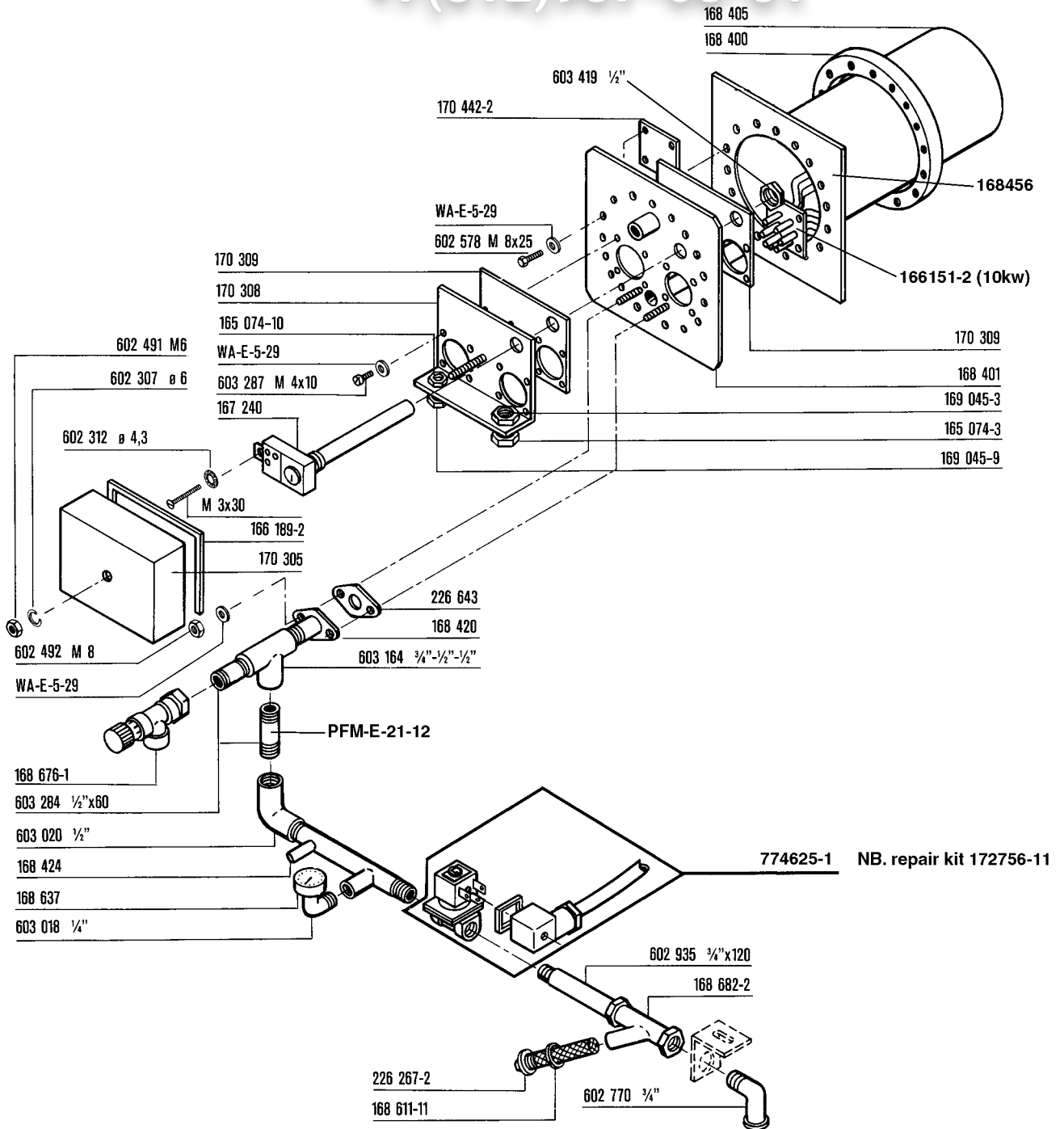

+7(812)987-08-81

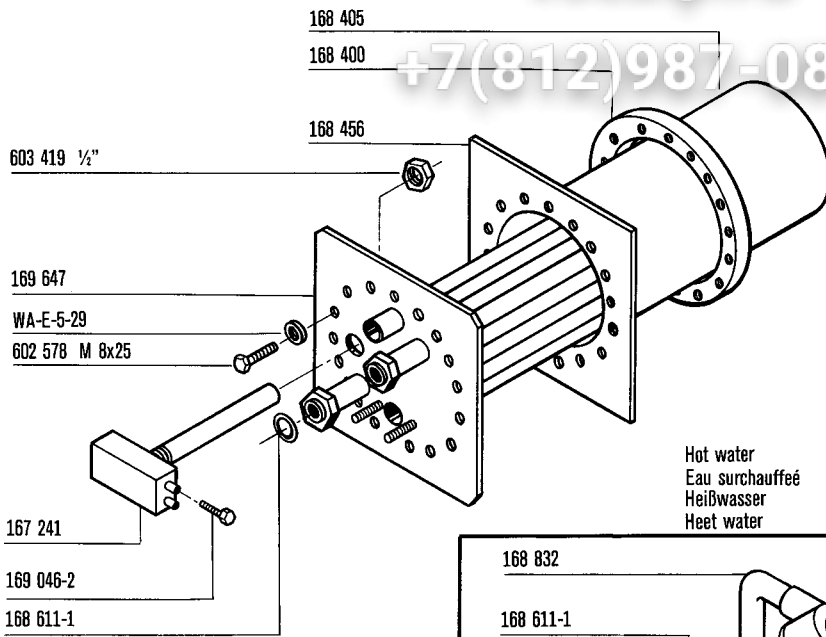

Hot water
 Eau surchauffée
 Heißwasser
 Heet water
 110-200°C

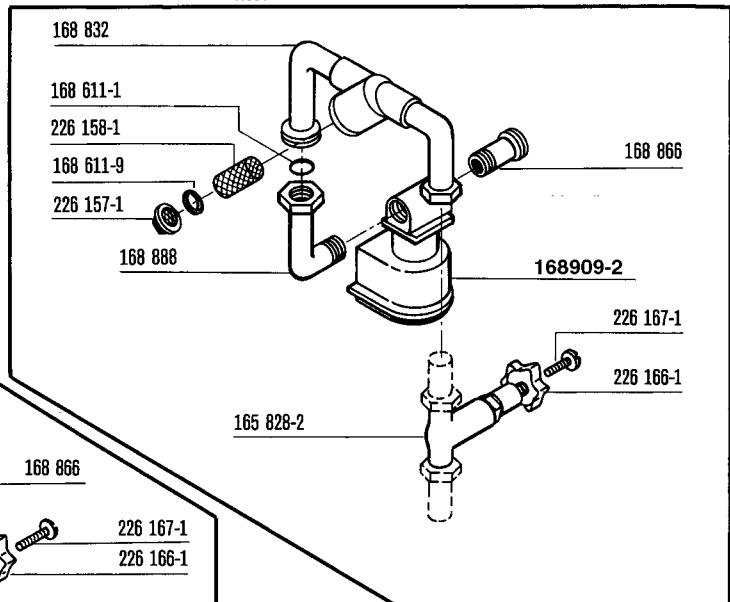
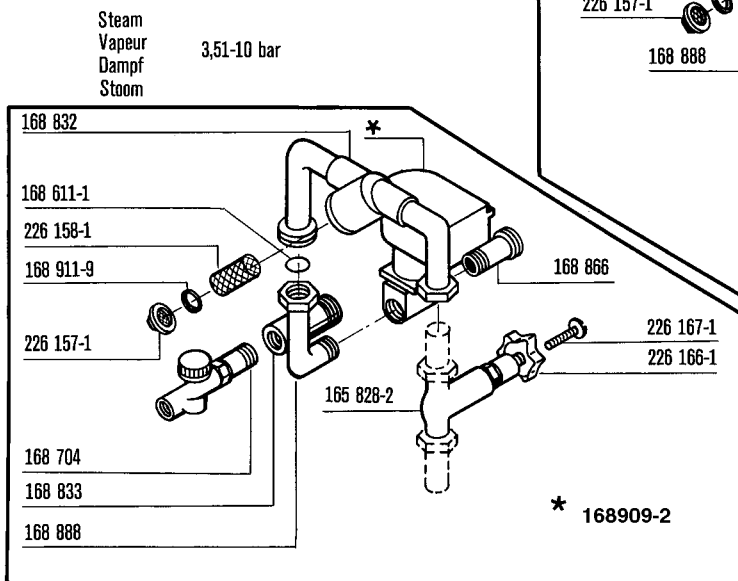

Steam
 Vapeur
 Dampf
 Stoom
 0.1-3.5 bar

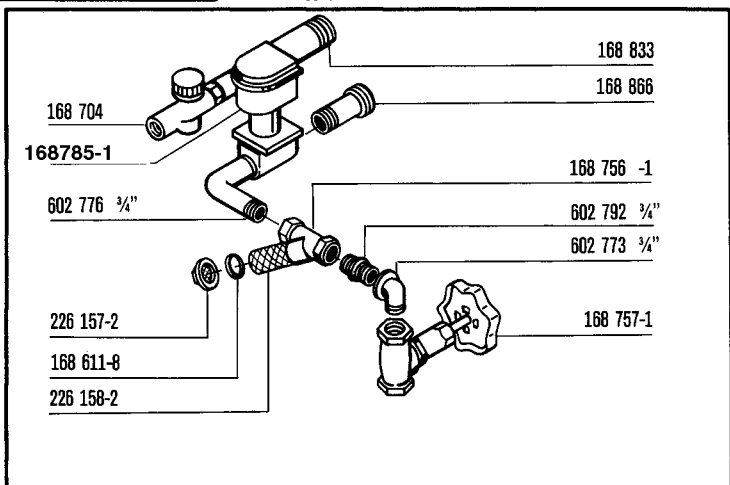

+7(812)987-08-81

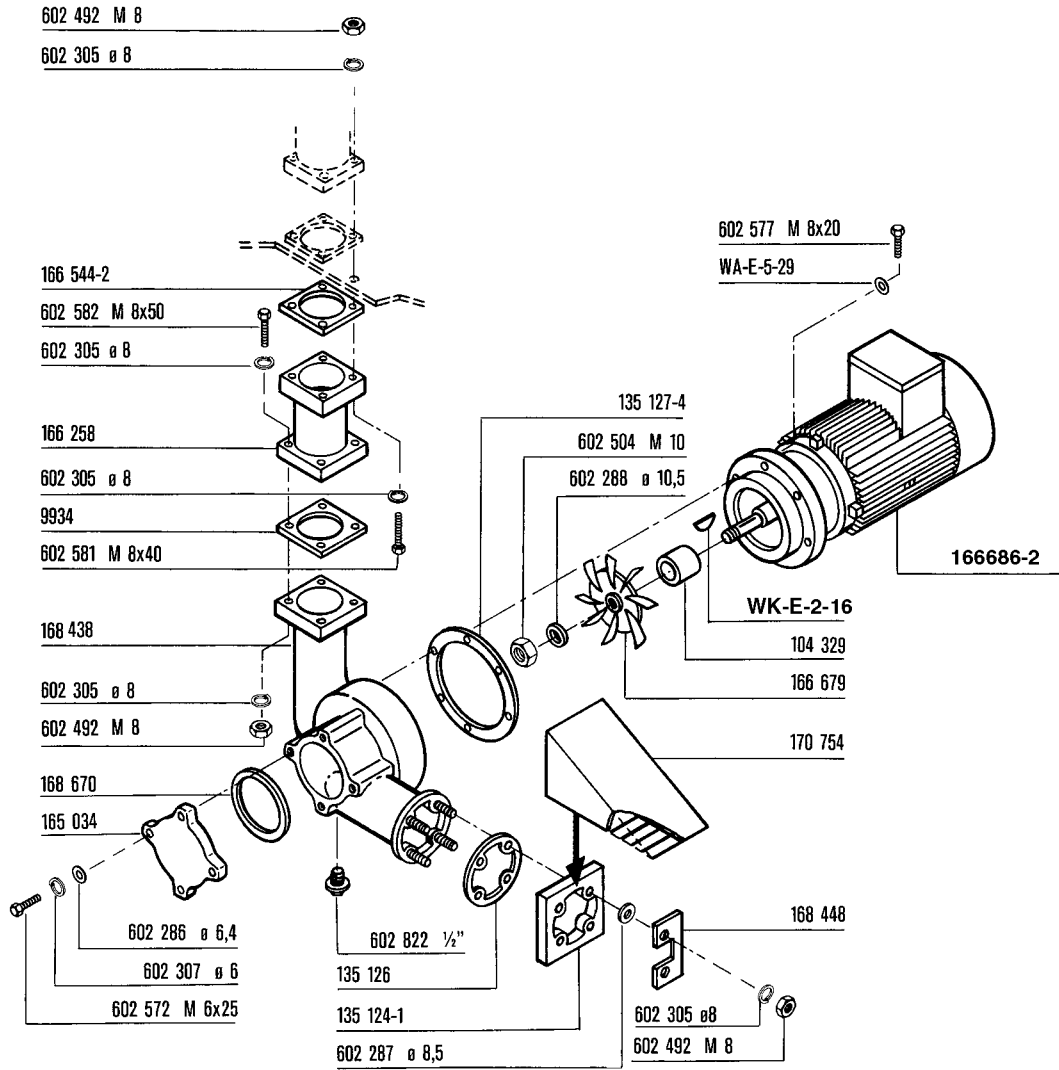

MOTOR BEARINGS
 BB-E-3-36 OR BB-E-2-44

+7(812)987-08-81

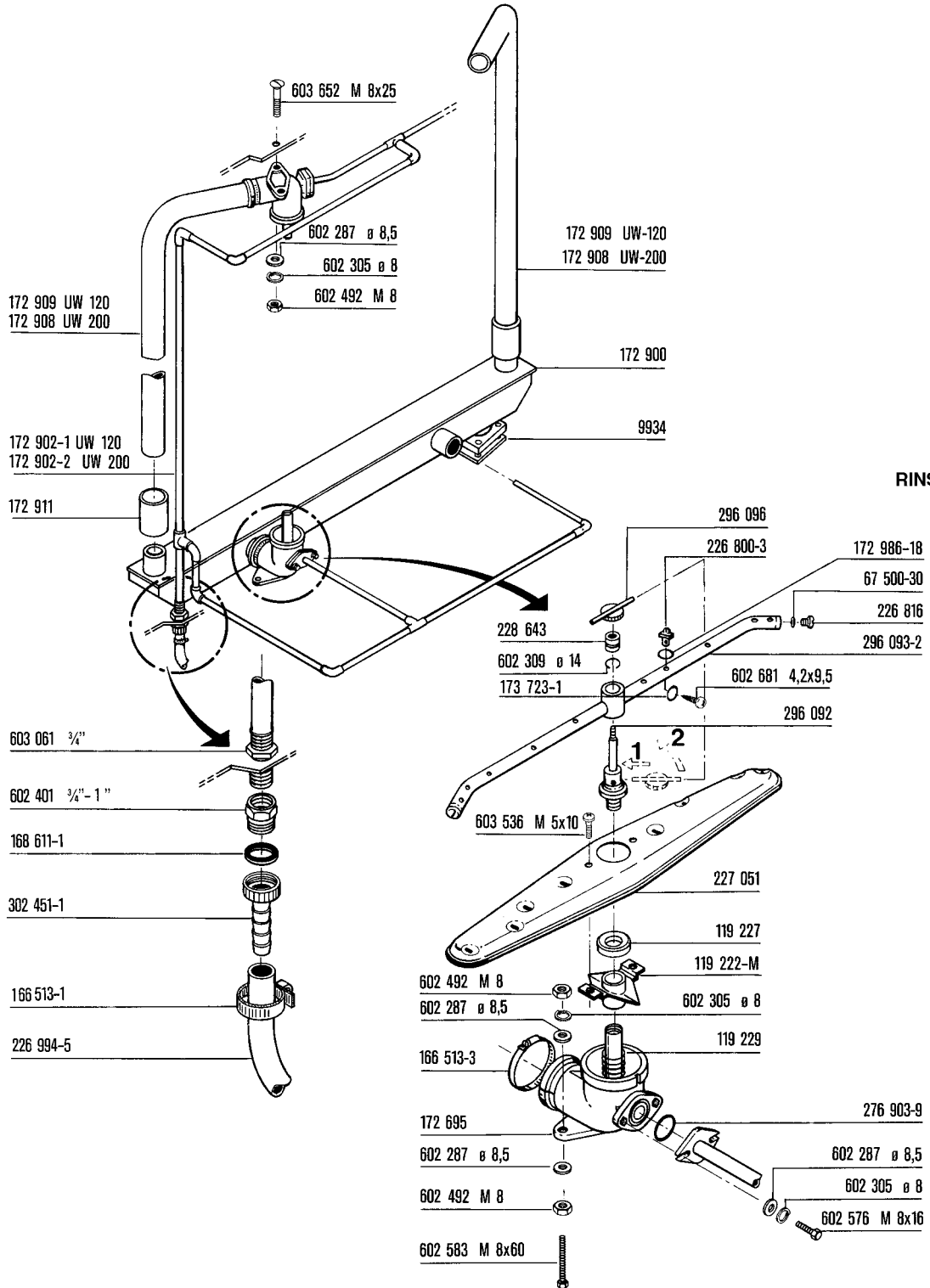

+7(812)987-08-81

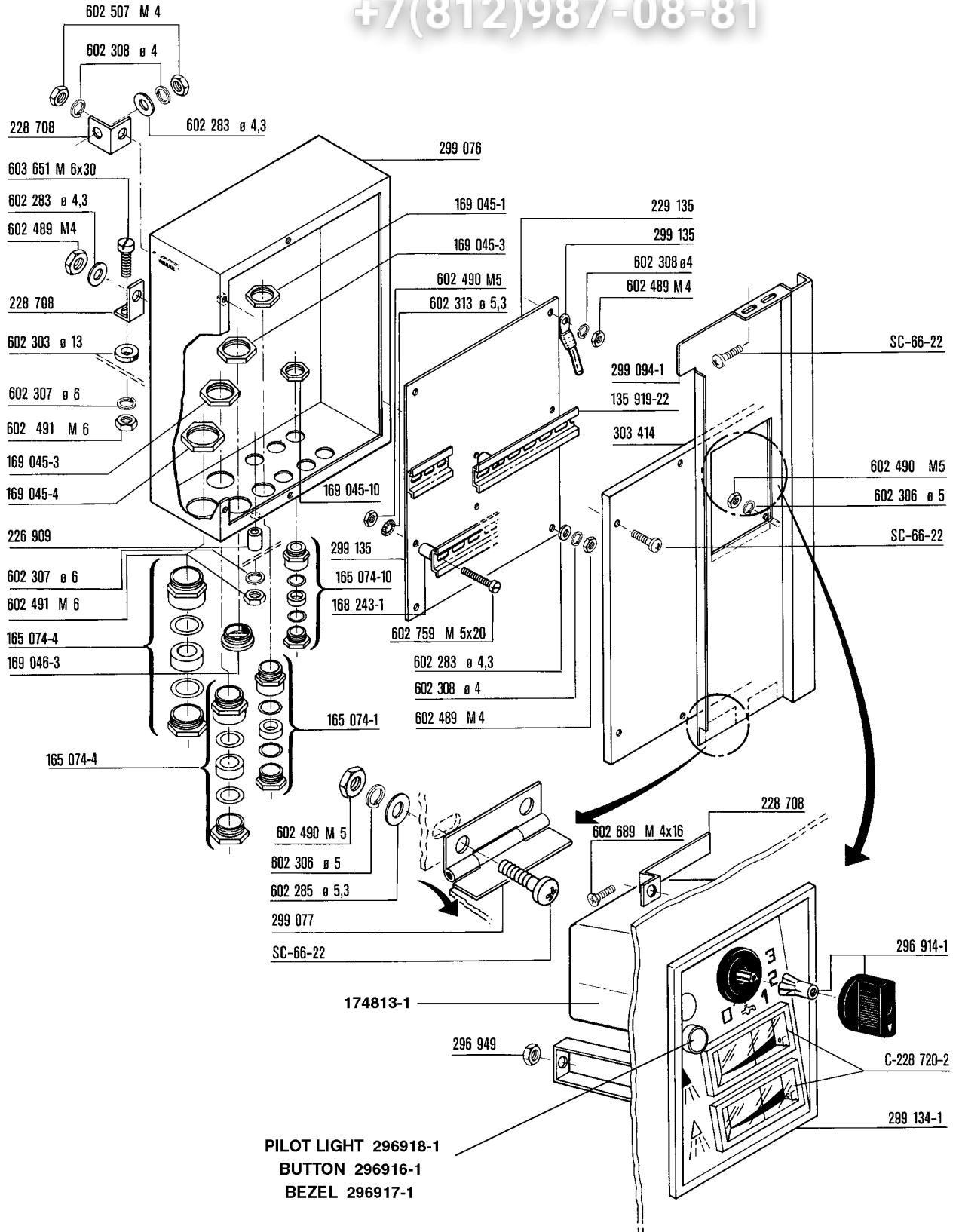

+7(812)987-08-81

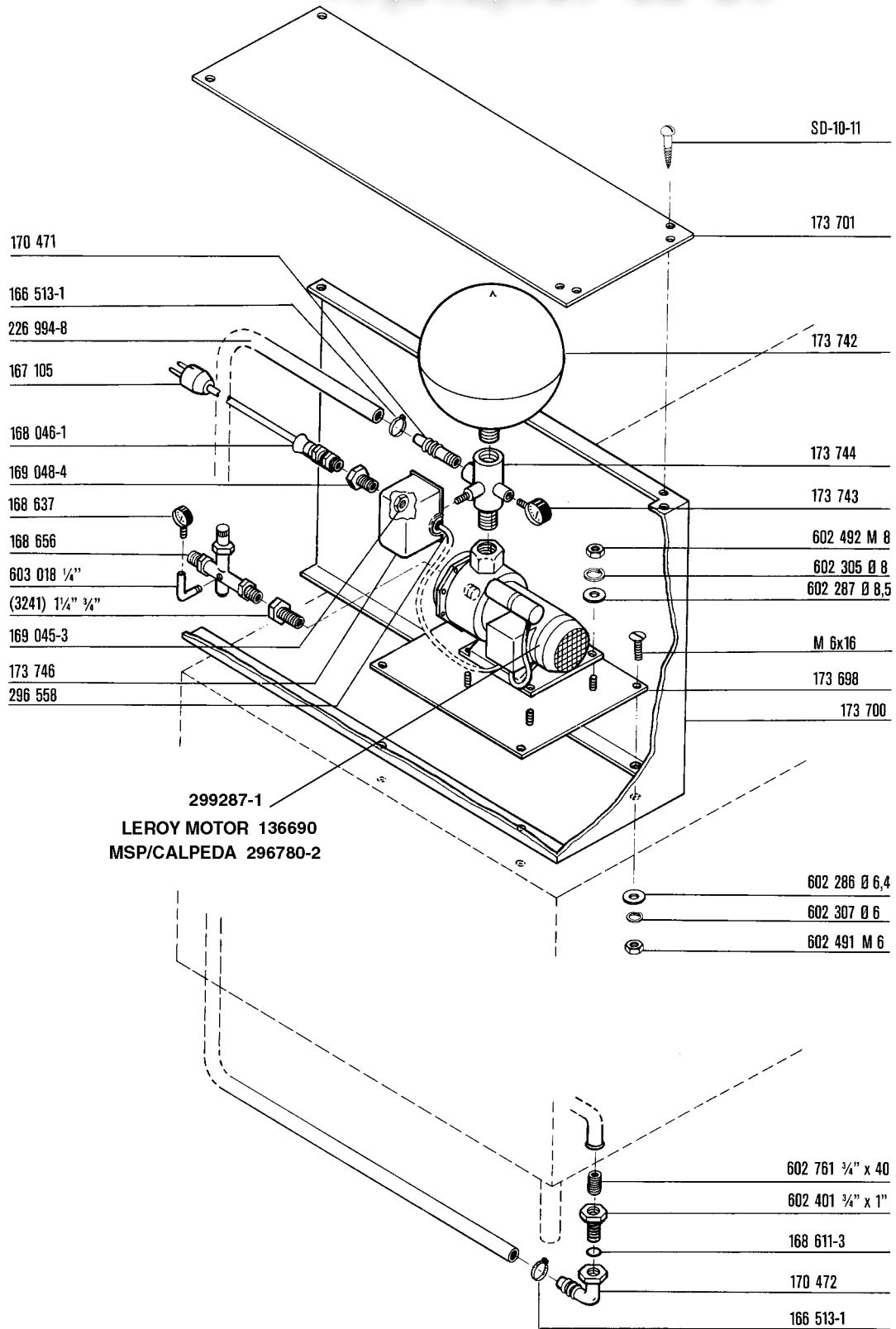

+7(812)987-08-81

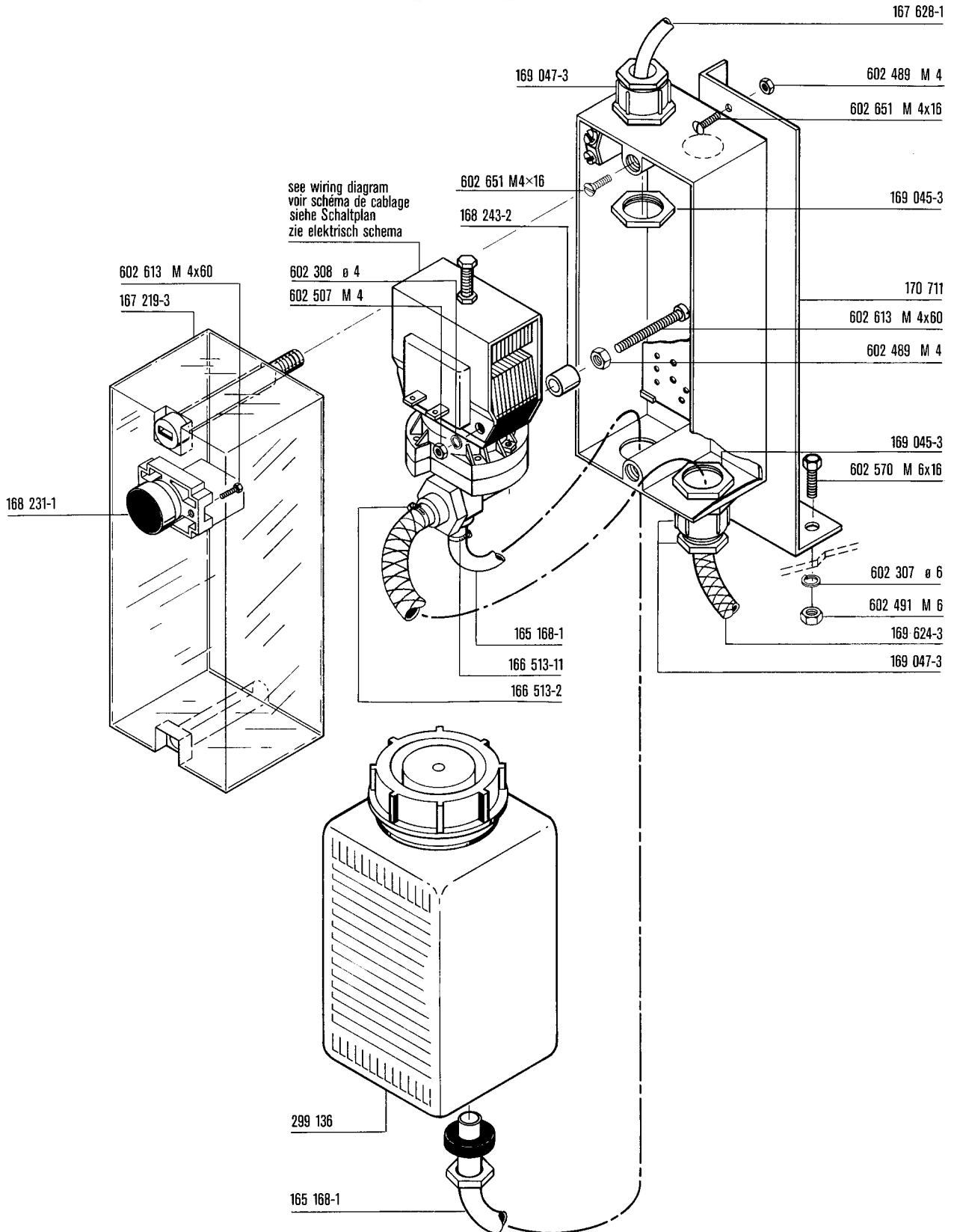

+7(812)987-08-81

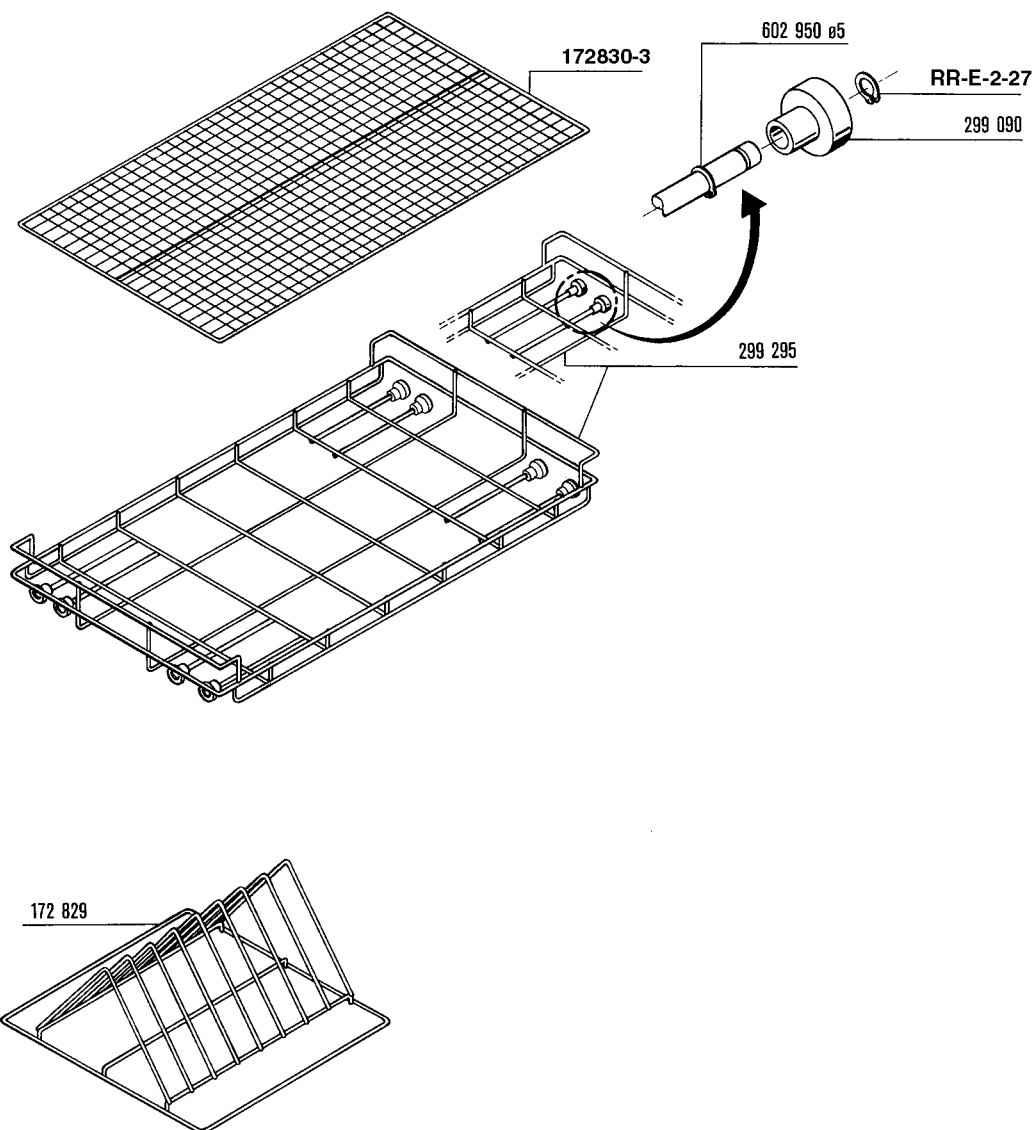

Зип Общепит

vsezip.ru

+7(812)987-08-81

Contents

Drain, strainers, frame and panels	2
Hood, door and track	3
Rinse booster heater, electric	4
Rinse booster heater, steam or hot water	5
Wash pump	6
Wash and rinse system	7
Control box	8
Rinse pressure pump	9
Rinse agent dispenser	10
Racks	11

Inhalt

Ablauf, Siebe, Gestell und Verkleidungen	2
Haube, Tür und Laufschiene	3
Durchlauferhitzer, elektrisch	4
Durchlauferhitzer, Dampf oder Heißwasser	5
Waschpumpe	6
Wasch- und Klarspülsystem	7
Schaltkasten	8
Drucksteigerungspumpe	9
Klarspülmittel-Dosiergerät	10
Körbe	11

Sommaire

Vidange, filtres, chassis et panneaux	2
Caisson, porte et rails	3
Surchauffeur, électrique	4
Surchauffeur, vapeur ou eau surchauffée	5
Pompe de lavage	6
Système de lavage et de rinçage	7
Coffret électrique	8
Pompe élévatrice de pression	9
Doseur de produit de rinçage	10
Paniers	11

Inhoud

Afvoer, zeven, tank en panelen	2
Kap, deur en rekkenrails	3
Booster, elektrisch	4
Booster, stoom of heet water	5
Waspomp	6
Was en spoelsysteem	7
Schakelkast	8
Spoeldrukomp	9
Spoelmiddel-doseerapparaat	10
Rekken	11

As continued product improvement is a policy of HOBART, specifications are subject to change without notice.

Ce catalogue n'est pas contractuel. HOBART se réserve le droit, et sans préavis, d'apporter toutes modifications ou améliorations à ses matériels.

HOBART behält sich das Recht vor, an allen Produkten technische Änderungen und Verbesserungen ohne Ankündigung vorzunehmen.

Voortdurende produktverbetering vormt een wezenlijk onderdeel van het beleid van HOBART. Specificaties kunnen zonder kennisgeving gewijzigd worden.