



Зип Общепит

CATALOG OF

vsezip.ru

+7(812)987-08-81
REPLACEMENT PARTS

MODEL C44A, C44AW, & C54A SERIES DISHWASHERS

C44A

ML-104047 R-L

ML-104050 L-R

C44AW

ML-104082 R-L

ML-104083 L-R

C54A

ML-104199 R-L

ML-104198 L-R

PRIOR MLS COVERED IN THIS MANUAL:

C44A

ML-38898 R-L

ML-38899 L-R

C44AW

ML-103946 R-L

ML-103947 L-R

Page	Description
3	Conduit – Waterproof
5	Control Box
6	Component Panel (Control Box) W/O 120 V. Pilot Circuit
8	Component Panel (Control Box) 120 V. Pilot Circuit
11	Wash Motor And Pump Unit
13	Conveyor Drive Unit (C44A Series – 1/4 Hp.)
15	Conveyor Drive Unit (C54A, C44A, & AW Series – 1/6 Hp.)
17	Conveyor Drive Train
18	Conveyor Drive – Motor Parts (Von Weise – 1/4 Hp.)
19	Conveyor Drive – Motor Parts (Bison – 1/4 Hp.)
21	Track And Cradle (Wash Section)
23	Wash Arms And Tubes (Wash Section – Previous Construction)
25	Wash Arms And Tubes (Wash Section)
26	Fill And Outside Rinse Piping (Previous Construction)
29	Fill And Outside Rinse Piping (Current Construction)
31	Inside Metallic Rinse Piping
33	Inside Non-Metallic Rinse Piping (C44A & AW Series)
35	Actuator Mechanism And Rinse Drain-Off Pan
37	Drain Unit (Wash Section)
39	Door, Curtains, Baffles, And Strainers
41	Vent Hood
43	Extended Hood
45	Miscellaneous (Wash Section)
47	Low Water Protection (Steam Heat/Wash Tank)
49	Steam Coil Heat
51	Piping – Steam Coils
53	Steam Injector Heat
54	Control Box – Gas Heat
57	Gas Burner And Flue
58	Gas Heat Components
61	Electric Heat
62	Dish Racks

This catalog contains parts for standard height as well as 6" higher than standard height. For proper identification of some parts, it is necessary to measure the door height; these parts are noted accordingly.

DOOR HEIGHT

26¹/₈ = Standard

32¹/₈ = 6" Higher than Standard

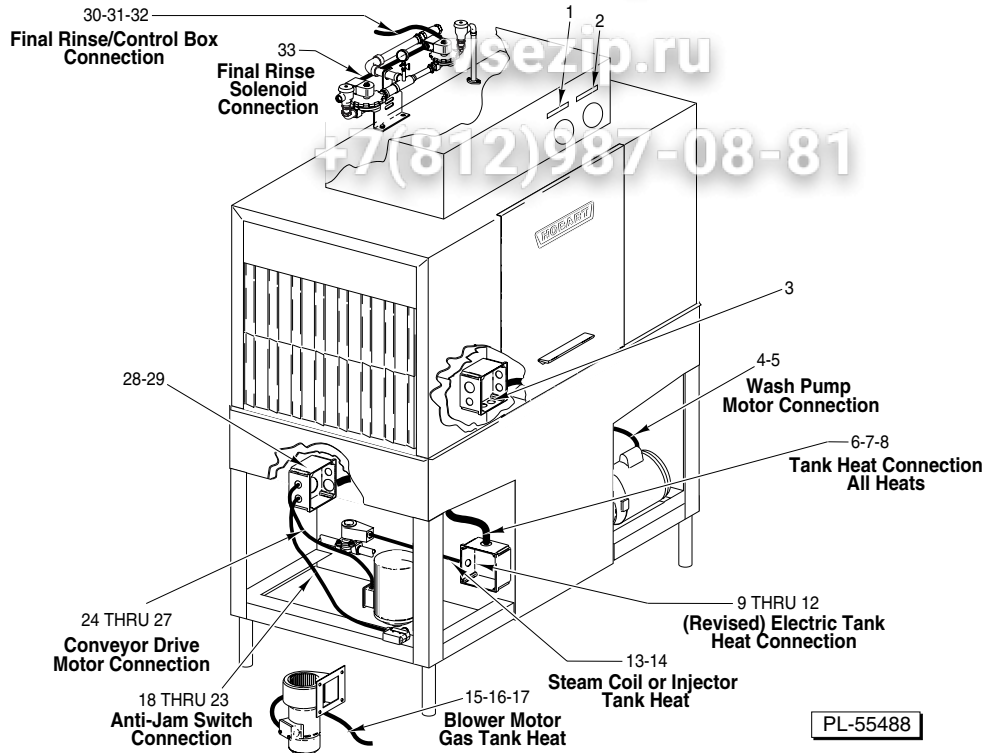

CONDUIT – WATERPROOF

ILLUS.	PART NO.	NAME OF PART	AMT.
PL-55488	Liquidtite	Non-Metallic	
1	00-329817	00-329817 Label – Temperature (Low Temp.)	1
2	00-329818	00-329818 Label – Temperature (High Temp.)	1
3	00-294947-00002	- Grounding Strap – Holes 1 1/8 Dia. & 7/8 Dia.	1
4	FE-007-07	FE-024-65 Connector – 90 Deg. Sealtite (1/2 Male Thd. x 1/2 Flex. Cnd.)	2
5	FE-008-10	FE-008-10 1/2 Gasket Assy.	AR
6	FE-008-33	FE-024-67 Connector – 90 Deg. Sealtite (1 Male Thd. x 1 Flex. Cnd.)	2
7	-	FE-006-50 Lock Nut 1 (Cnd.)	1
8	FE-008-12	FE-008-12 Gasket	AR
9	-	FE-024-59 Connector – Straight Sealtite (1 Male Thd. x 1 Flex Cnd.)	1
10	-	FE-024-63 Connector – 45 Deg. Sealtite (1 Male Thd. x 1 Flex Cnd.)	1
11	-	FE-006-50 Lock Nut 1 (Cnd.)	1
12	-	FE-008-12 Gasket	1
13	FE-007-01	- Connector – Straight Sealtite (1/2 Male Thd. x 3/8 Flex. Cnd.)	2
14	-	FE-024-57 Connector – Straight Sealtite (1/2 Male Thd. x 1/2 Flex Cnd.)	2
15	FE-007-05	FE-024-61 Connector – 45 Deg. Sealtite (1/2 Male Thd. x 1/2 Flex. Cnd.)	2
16	FE-007-04	FE-024-57 Connector – Straight Sealtite (1/2 Cable x 1/2 Flex. Cnd.)	1
17	FE-008-10	- 1/2 Gasket Assy.	2
18	FE-007-01	- Connector – Straight Sealtite (1/2 Male Thd. x 3/8 Flex. Cnd.)	1
19	-	FE-024-57 Connector – Straight Sealtite (1/2 Male Thd. x 1/2 Flex Cnd.)	1
20	FE-007-02	- Connector – 45 Deg. Sealtite (1/2 Male Thd. x 3/8 Flex. Cnd.)	1
21	-	FE-024-61 Connector – 45 Deg. Sealtite (1/2 Male Thd. x 1/2 Flex Cnd.)	1
22	FE-006-07	FE-006-07 Lock Nut 1/2 (Cnd.)	1
23	FE-008-10	FE-008-10 1/2 Gasket Assy.	AR
24	FE-007-05	FE-024-61 Connector – 45 Deg. Sealtite (1/2 Male Thd. x 1/2 Flex. Cnd.)	1
25	FE-007-07	FE-024-65 Connector – 90 Deg. Sealtite (1/2 Male Thd. x 1/2 Flex. Cnd.)	1
26	FE-006-07	FE-006-07 Lock Nut 1/2 (Cnd.)	1
27	FE-008-10	FE-008-10 1/2 Gasket Assy.	2
28	00-294947-00001	- Grounding Strap – Holes 1" Dia. & 1" Dia.	1
29	00-294947-00003	- Grounding Strap – Holes 1 1/8 Dia. & 1 3/8 Dia.	1
30	FE-007-05	FE-024-61 Connector – 45 Deg. Sealtite (1/2 Male Thd. x 1/2 Flex. Cnd.)	1
31	FE-007-07	FE-024-65 Connector – 90 Deg. Sealtite (1/2 Male Thd. x 1/2 Flex. Cnd.)	1
32	FE-008-10	- 1/2 Gasket Assy.	1
33	FE-007-04	FE-024-57 Connector – Straight Sealtite (1/2 Cable x 1/2 Flex. Cnd.)	2

vsezip.ru

+7(812)987-08-81

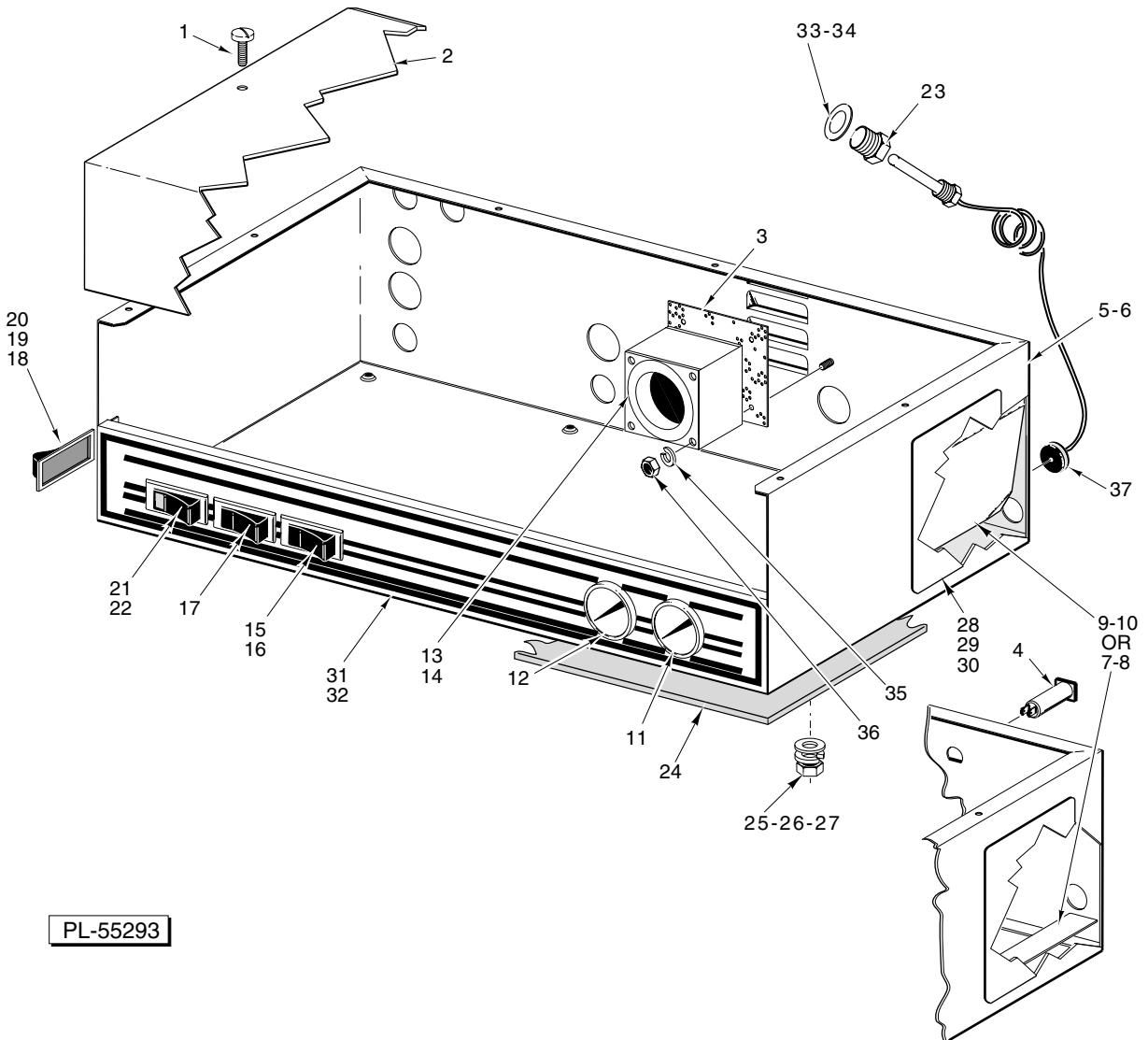

PL-55293

CONTROL BOX

vsezip.ru

+7(812)987-08-81

CONTROL BOX

ILLUS.	PART NO.	NAME OF PART	AMT.
PL-55293			
1	SC-066-05	Mach. Screw 10-24 x 3/8 Phil. Truss Hd.	2
2	00-436755-00001	Cover – Control Box	1
3	00-274884	Guard – Fan	1
*4	00-256154	Circuit Breaker	1
*5	00-271069	Control Box (Give Electric Spec., Machine Model, & Serial Number)	1
**6	00-435505-00001	Control Box (Give Electric Spec., Machine Model, & Serial Number)	1
7	00-274948	Shield	1
8	SD-008-25	Self-Tapping Screw 10-16 x 1/2 Phil. Pan Hd., Type B	1
9	00-328137	Shield	1
10	NS-031-15	Stop Nut 10-24 Hex (SST)	2
11	00-437041-00003	Thermometer (8 Ft.) (Rinse)	1
12	00-437041-00004	Thermometer (11 Ft.) (Wash)	1
*13	00-415207-00002	Fan Cooling (230 V.)	1
**14	00-355504-00001	Fan (115 V.)	1
**15	00-087711-241-2	Switch – Rocker (DPDT) (Conveyor Dwell)	1
*16	00-087711-192-2	Switch – Rocker (On/Off) (Conveyor Dwell)	1
17	00-087711-228-1	Switch – Rocker (Motor On/Off)	1
**18	00-087711-241-2	Switch – Rocker (On/Off) (Timer)	1
*19	00-087711-192-2	Switch – Rocker (On/Off) (Timer)	1
20	00-271840	Label – Timer	1
**21	00-087711-198-2	Switch – Rocker (Power On/Off) (115 V.)	1
*22	00-087711-198-6	Switch – Rocker (Power On/Off) (240 V.)	1
23	00-107218	Coupling – Thermometer Bulb	2
24	00-435072	Gasket	1
25	WS-022-01	Washer	6
26	WL-006-17	Lockwasher 1/4 Medium	6
27	NS-031-21	Stop Nut – Special 1/4-20 Hex	6
28	00-274962	Label – Instruction (C44A Series)	1
29	00-436354	Label – Instruction (C44AW Series)	1
30	00-475088	Label – Instruction (C54A Series)	1
31	00-812850	Label – Control Box (W/O Conveyor Dwell)	AR
32	00-812852	Label – Control Box (Conveyor Dwell)	AR
33	WS-012-40	Washer	4
34	FP-053-05	Pipe Locknut 1/2 NPSL (SST)	2
35	WL-006-42	Lockwasher #6 Medium	3
36	NS-011-07	Mach. Nut 6-32 Hex	3
37	00-274947	Grommet	1
	FE-021-12	Plug – 1/2 Knockout (Plastic)	AR
	FE-023-26	Plug – 1 Knockout (Plastic)	AR

* Machines W/O 120 V. pilot circuit.

** Machines W/ 120 V. pilot circuit.

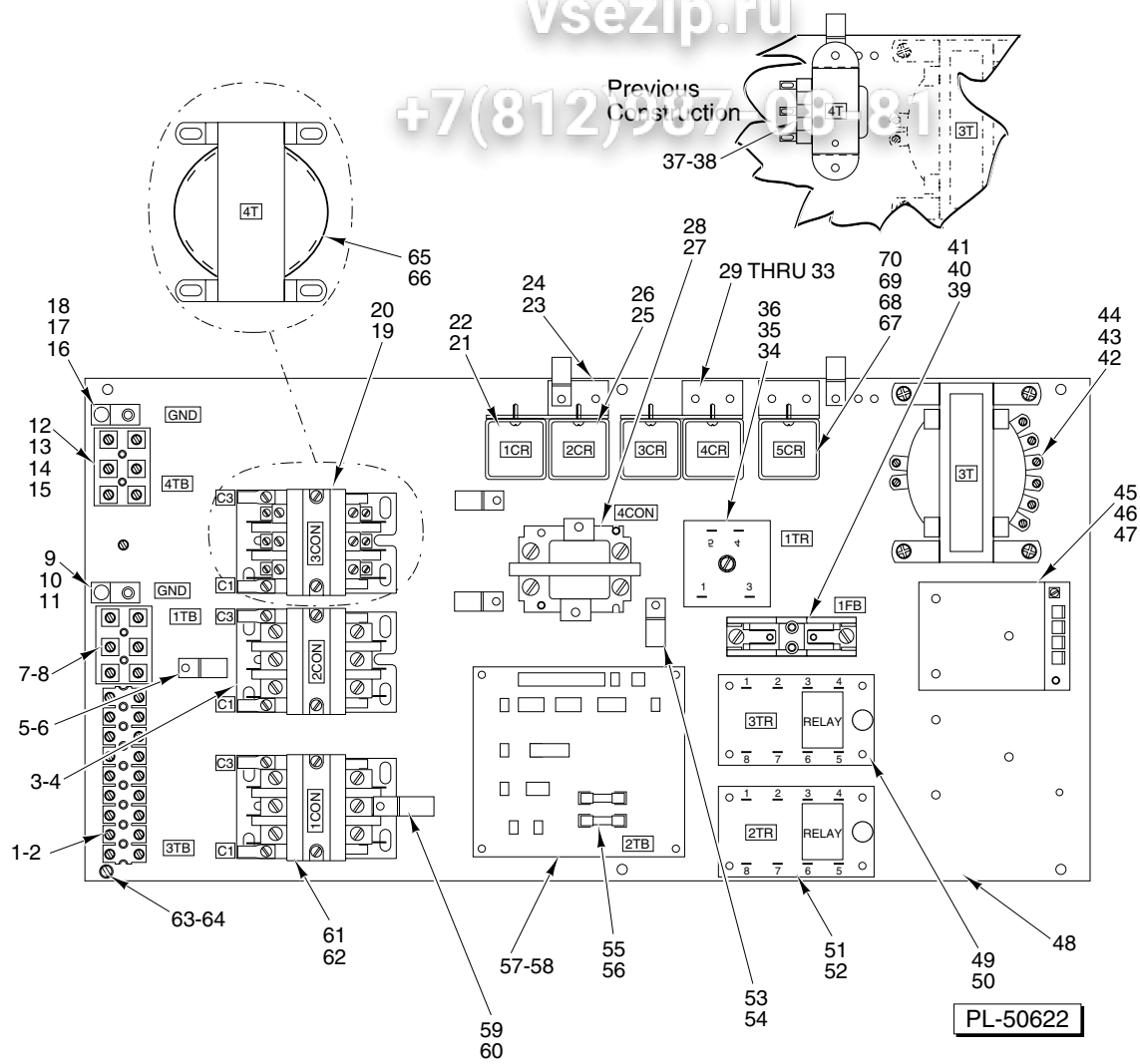

**COMPONENT PANEL
(CONTROL BOX)
W/O 120 V. PILOT CIRCUIT**

ILLUS.	PART NO.	NAME OF PART	AMT.
	PL-50622		
1	00-294325-013-1	Terminal Block	1
2	SD-019-29	Self-Tapping Screw 6-20 x 1/2 Phil. Pan Hd., Type B	2
3	00-087713-040-1	Contactator 30 Amp. 3 Pole (Machines W/Conveyor Dwell)	1
4	SD-008-25	Self-Tapping Screw 10-16 x 1/2 Phil. Pan Hd., Type B	2
5	00-294677-00002	Clamp - Wire (1/2 I.D.)	1
6	SD-008-25	Self-Tapping Screw 10-16 x 1/2 Phil. Pan Hd., Type B	1
7	00-294325-003-1	Block - Terminal	AR
8	SD-037-21	Self-Tapping Screw 8-32 x 1 Phil. Hd., Type F	AR
9	00-118544-00002	Lug - Grounding	AR
10	SD-008-25	Self-Tapping Screw 10-16 x 1/2 Phil. Pan Hd., Type B	AR
11	WL-007-12	Lockwasher #10 External Shakeproof	AR
12	00-294325-003-1	Block - Terminal	AR
*13	00-294325-004-1	Terminal Block	1

**COMPONENT PANEL (Cont.)
(CONTROL BOX)
W/O 120 V. PILOT CIRCUIT**

+7(812)987-08-81

ILLUS. PL-50622	PART NO.	NAME OF PART	AMT.
14	SD-037-21	Self-Tapping Screw 8-32 x 1 Phil. Fil Hd., Type F (Use with Item 12 on 3 Ph. Machines)	2
15	SD-008-36	Self-Tapping Screw 8-18 x 7/16 Phil. Rd. Hd., Type B (Use with Item 13 or 12 on 1 Ph. Mach.) ...	2
16	00-118544-00002	Lug – Grounding	1
17	SD-008-25	Self-Tapping Screw 10-16 x 1/2 Phil. Pan Hd., Type B	1
18	WL-007-12	Lockwasher #10 External Shakeproof	1
19	00-087713-041-1	Contactor 40 Amp. 3 Pole (Electric Heat)	1
20	SD-008-25	Self-Tapping Screw 10-16 x 1/2 Phil. Pan Hd., Type B	2
21	00-205113-00002	Relay 3 P.D.T.	1
22	SD-019-29	Self-Tapping Screw 6-20 x 1/2 Phil. Pan Hd., Type B	1
23	00-271066	Bracket	1
24	SD-008-18	Self-Tapping Screw 8-18 x 3/8 Phil. Bind Hd., Type B	2
25	SD-019-29	Self-Tapping Screw 6-20 x 1/2 Phil. Pan Hd., Type B	2
26	00-087714-007-3	Relay D.P.D.T.	1
27	SD-008-25	Self-Tapping Screw 10-16 x 1/2 Phil. Pan Hd., Type B	2
28	00-087713-049-2	Contactor (Machines W/Vent Fan Control)	1
29	00-271066	Bracket	1
30	SD-008-18	Self-Tapping Screw 8-18 x 3/8 Phil. Bind Hd., Type B	2
31	00-205113-00002	Relay 3 P.D.T.	1
32	00-205113-00002	Relay 3 P.D.T.	1
33	SD-019-29	Self-Tapping Screw 6-20 x 1/2 Phil. Pan Hd., Type B	2
34	00-087714-031-1	Relay Time Delay	1
35	SD-034-70	Self-Tapping Screw 1/4-20 x 1 Slotted Hex Washer Hd.	1
36	WL-007-15	Lockwasher 1/4 External Shakeproof	1
37	00-294500-00017	Transformer 24 V. (Gas Heat)	1
38	SD-008-25	Self-Tapping Screw 10-16 x 1/2 Phil. Pan Hd., Type B	2
39	00-294436-00005	Fuse Block (Gas Heat)	1
40	SD-008-18	Self-Tapping Screw 8-18 x 3/8 Phil. Bind Hd., Type B (Gas Heat)	2
41	FE-022-45	Fuse (5 Amp.) (300 V.) (Gas Heat)	1
42	00-294500-018-1	Transformer (150 VA) Pilot Control	1
43	00-294500-018-2	Transformer (250 VA) Pilot Control (Machines W/Blower Dryer or Condenser)	1
44	SD-008-25	Self-Tapping Screw 10-16 x 1/2 Phil. Pan Hd., Type B	4
45	00-274629-00002	Thermostat – Solid State (230 V.)	1
46	SC-098-07	Mach. Screw 4-40 x 1 3/4 Rd. Hd. (SST)	3
47	WS-028-12	Washer	3
48	00-271065	Base Plate	1
49	00-087714-028-2	Time Delay Relay (Machines W/Vent Fan Control)	1
50	SD-014-26	Self-Tapping Screw 6-32 x 3/4 Slotted Pan Hd., Type D	2
51	00-087714-028-2	Relay Time Delay	1
52	SD-014-26	Self-Tapping Screw 6-32 x 3/4 Slotted Pan Hd., Type D	2
53	00-294677-00003	Clamp – Wire (3/4 I.D.)	3
54	SD-008-25	Self-Tapping Screw 10-16 x 1/2 Phil. Pan Hd., Type B	3
55	FE-022-74	Fuse (0.6 Amp.) (500 V.) (380-480 V. Mach. W/O Blower Dryer or Condenser)	2
56	FE-022-86	Fuse (0.8 Amp.) (500 V.) (380-480 V. Mach. W/Blower Dryer and/or Condenser)	2
57	00-294676	PCB – Terminal & Fuse	1
58	SD-008-18	Self-Tapping Screw 8-18 x 3/8 Phil. Bind Hd., Type B	4
59	00-294677-00004	Clamp – Wire (1 I.D.)	3
60	SD-008-25	Self-Tapping Screw 10-16 x 1/2 Phil. Pan Hd., Type B	2
61	00-087713-040-1	Contactor 30 Amp., 3 Pole	1
62	SD-008-25	Self-Tapping Screw 10-16 x 1/2 Phil. Pan Hd., Type B	2
63	WL-007-12	Lockwasher #10 External Shakeproof	6
64	SC-053-05	Mach. Screw 10-24 x 3/8 Truss Hd., Slotted	6
65	00-294500-021-1	Transformer 24 & 120 V. Secondary (Gas Heat)	1
66	SD-008-25	Self-Tapping Screw 10-16 x 1/2 Phil. Pan Hd., Type B	4
67	00-205113-00002	Relay 3 P.D.T.	1
68	SD-019-29	Self-Tapping Screw 6-20 x 1/2 Phil. Pan Hd., Type B	1
69	00-186748	Relay Mounting	1
70	SD-008-18	Self-Tapping Screw 8-18 x 3/8 Phil. Bind Hd., Type B	2

* Single point electrical connection, 3 Ph., or 200-240 V., 1 Ph. machines
W/O single point electrical connection. Electric heat only.

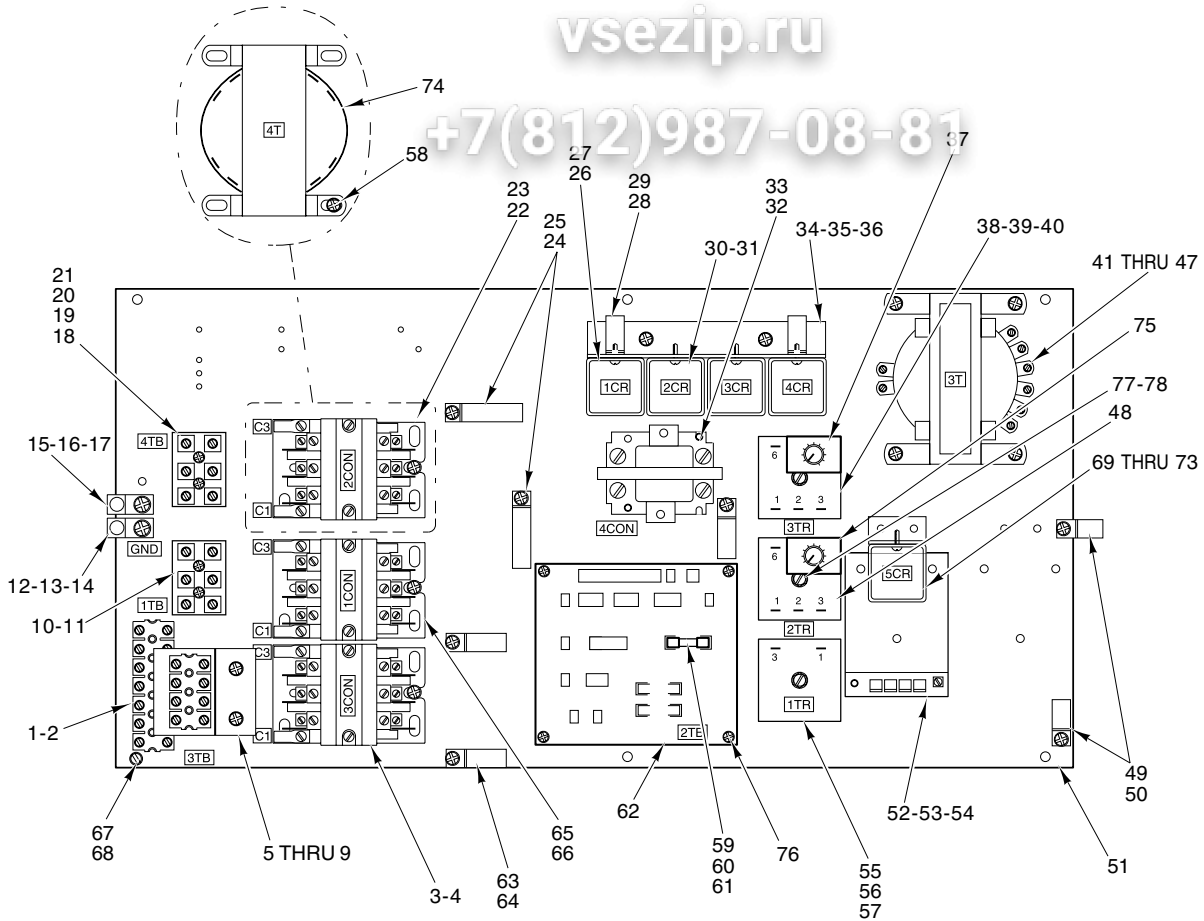

PL-51065

**COMPONENT PANEL
(CONTROL BOX)
120 V. PILOT CIRCUIT**

ILLUS.	PART NO.	NAME OF PART	AMT.
PL-51065			
1	00-294325-013-5	Block – Terminal	1
2	SD-019-29	Self-Tapping Screw 6-20 x 1/2 Phil. Pan Hd., Type B	2
3	00-087713-041-2	Contactors 40 Amp. 3 Pole (Machines W/Conveyor Dwell)	1
4	SD-008-25	Self-Tapping Screw 10-16 x 1/2 Phil. Pan Hd., Type B	2
5	00-294325-013-4	Terminal – Block (Machines W/Vent Fan Control)	1
6	00-437101	Bracket – Vent Fan Control	1
7	SD-008-25	Self-Tapping Screw 10-16 x 1/2 Phil. Pan Hd., Type B	2
8	WL-014-07	Lockwasher #10 External Shakeproof (SST)	2
9	SD-019-29	Self-Tapping Screw 6-20 x 1/2 Phil. Pan Hd., Type B	2
10	00-294325-015-1	Block – Terminal	1
11	SD-037-21	Self-Tapping Screw 8-32 x 1 Phil. Hd., Type F	2
12	00-118544-00002	Lug – Grounding	1
13	SD-035-77	Self-Tapping Screw 1/4-20 x 3/8 Phil. Pan Hd., Type TT	1
14	WL-007-15	Lockwasher 1/4 External Shakeproof	1
15	00-118544-00002	Lug – Grounding (Electric Heat)	1
16	SD-035-77	Self-Tapping Screw 1/4-20 x 3/8 Phil. Pan Hd., Type TT	1
17	WL-007-15	Lockwasher 1/4 External Shakeproof	1
18	00-294325-015-1	Block – Terminal (200-240 V., 380-480 V., 3 Ph. Electric Heat)	2
19	00-294325-004-1	Block – Terminal (Not Shown) (200-240 V., 1 Ph., Electric Heat) (S.P.E.C.)	2

COMPONENT PANEL (Cont.)
(CONTROL BOX)

+7(812)987-08-81

ILLUS.	PART NO.	NAME OF PART	AMT.
PL-51065			
20	SD-037-21	Self-Tapping Screw 8-32 x 1 Fil. Phil. Hd. Type F (Use W/Item 18 on 3 Ph. Machines)	2
21	SD-008-36	Self-Tapping Screw 8-18 x 7/8 Phil. Rd. Hd. Type B (Use W/Item 19 on 1 Ph. Machines)	2
22	00-087713-041-2	Contactor 40 Amp. 3 Pole (Electric Heat)	1
23	SD-008-25	Self-Tapping Screw 10-16 x 1/2 Phil. Pan Hd., Type B	2
24	00-294677-00005	Clamp - Wire (1 1/2 I.D.)	2
25	SD-008-25	Self-Tapping Screw 10-16 x 1/2 Phil. Pan Hd., Type B	2
26	00-205113-00001	Relay - 3 PDT (1CR, 3CR, & 4CR)	3
27	SD-019-29	Self-Tapping Screw 6-20 x 1/2 Phil Pan Hd., Type B	3
28	00-294677-00004	Clamp - Wire (1 I.D.)	2
29	SD-008-25	Self-Tapping Screw 10-16 x 1/2 Phil. Pan Hd., Type B	2
30	00-087714-007-2	Relay - D.P.D.T. (115 V.)	1
31	SD-019-29	Self-Tapping Screw 6-20 x 1/2 Phil. Pan Hd., Type B	2
32	00-112527	Contactor (Machines W/Vent Fan Control)	1
33	SD-008-25	Self-Tapping Screw 10-16 x 1/2 Phil. Pan Hd., Type B	2
34	00-437103	Bracket - Relay Mounting	1
35	SD-008-25	Self-Tapping Screw 10-16 x 1/2 Phil. Pan Hd., Type B	2
36	WL-014-07	Lockwasher #10 External Shakeproof (SST)	2
37	00-437070-00001	Plug On Module (Machines W/Vent Fan Control)	1
38	00-087714-00036	Relay Time Delay (Variable) (Machines W/Vent Fan Control)	1
39	SD-036-13	Self-Tapping Screw 1/4-20 x 1 1/4 Hex Washer Hd., Type T	1
40	WL-007-15	Lockwasher 1/4 External Shakeproof	1
41	00-294500-046-1	Transformer (150 VA) Pilot Control	1
42	00-294500-046-2	Transformer (300 VA) Pilot Control	1
43	00-294500-046-3	Transformer (500 VA) Pilot Control	1
44	SD-008-25	Self-Tapping Screw 10-16 x 3/8 Phil. Bind Hd., Type B (Use W/Item 41 or 42)	4
45	WL-014-07	Lockwasher #10 External Shakeproof (SST) (Use W/Item 41 or 42)	4
46	SD-035-77	Self-Tapping Screw 1/4-20 x 3/8 Phil. Pan Hd., Type TT (Use W/Item 43)	4
47	WL-007-15	Lockwasher 1/4 External Shakeproof (Use W/item 43)	4
48	00-087714-00036	Relay Time Delay (Variable)	1
49	00-294677-00005	Clamp - Wire (1 1/2 I.D.)	2
50	SD-008-25	Self-Tapping Screw 10-16 x 1/2 Phil. Pan Hd., Type B	2
51	00-435508	Base Plate	1
52	00-274629-00001	Thermostat - Solid State (120 V.)	1
53	SC-098-07	Mach. Screw 4-40 x 1 3/4 Rd. Hd.(SST)	3
54	WS-028-12	Washer	3
55	00-087714-031-2	Relay Time Delay (5 Sec.)	1
56	SD-036-13	Self-Tapping Screw 1/4-20 x 1 1/4 Hex Washer Hd., Type T	1
57	WL-007-15	Lockwasher 1/4 External Shakeproof	1
58	SD-008-25	Self-Tapping Screw 10-16 x 1/2 Phil. Pan Hd., Type B	4
59	FE-022-39	Fuse (1.5 Amp.) (250 V.) (60 Hz. Machines W/O Blower Dryer or Condenser)	1
60	FE-021-19	Fuse (3.2 Amp.) (125 V.) (50 Hz. & 50/60 Hz. Machines W/Blower Dryer and/or Condens	1
61	FE-023-25	Fuse (5 Amp.) (125 V.) (380-480 V. Gas Heat Machine W/Blower Dryer and/or Condenser) ...	1
62	00-294676	P.C.B. - Terminal & Fuse	1
63	00-294677-00004	Clamp - Wire (1 I.D.)	3
64	SD-008-25	Self-Tapping Screw 10-16 x 1/2 Phil. Pan Hd., Type B	3
65	00-087713-040-2	Contactor - 30 Amp., 3 Pole	1
66	SD-008-25	Self-Tapping Screw 10-16 x 1/2 Phil. Pan Hd., Type B	2
67	SC-053-05	Mach. Screw 10-24 x 3/8 Truss Hd., Slotted	6
68	WL-007-12	Lockwasher #10 External Shakeproof	6
69	00-205113-00001	Relay - 3 PDT (5CR)	1
70	00-437102	Bracket - Relay Mounting	1
71	SD-008-18	Self-Tapping Screw 8-18 x 3/8 Phil. Bind Hd., Type B	2
72	WL-014-05	Lockwasher #8 External Shakeproof	2
73	SD-019-29	Self-Tapping Screw 6-20 x 1/2 Phil. Pan Hd., Type B	2
74	00-294500-021-1	Transformer 24 & 120 V. Secondary (Gas Heat)	1
75	00-437070-00001	Plug On Module	1
76	SD-008-18	Self-Tapping Screw 8-18 x 3/8 Phil. Bind Hd., Type B	4
77	SD-036-13	Self-Tapping Screw 1/4-20 x 1 1/4 Hex Washer Hd., Type T	1
78	WL-007-15	Lockwasher 1/4 External Shakeproof	1

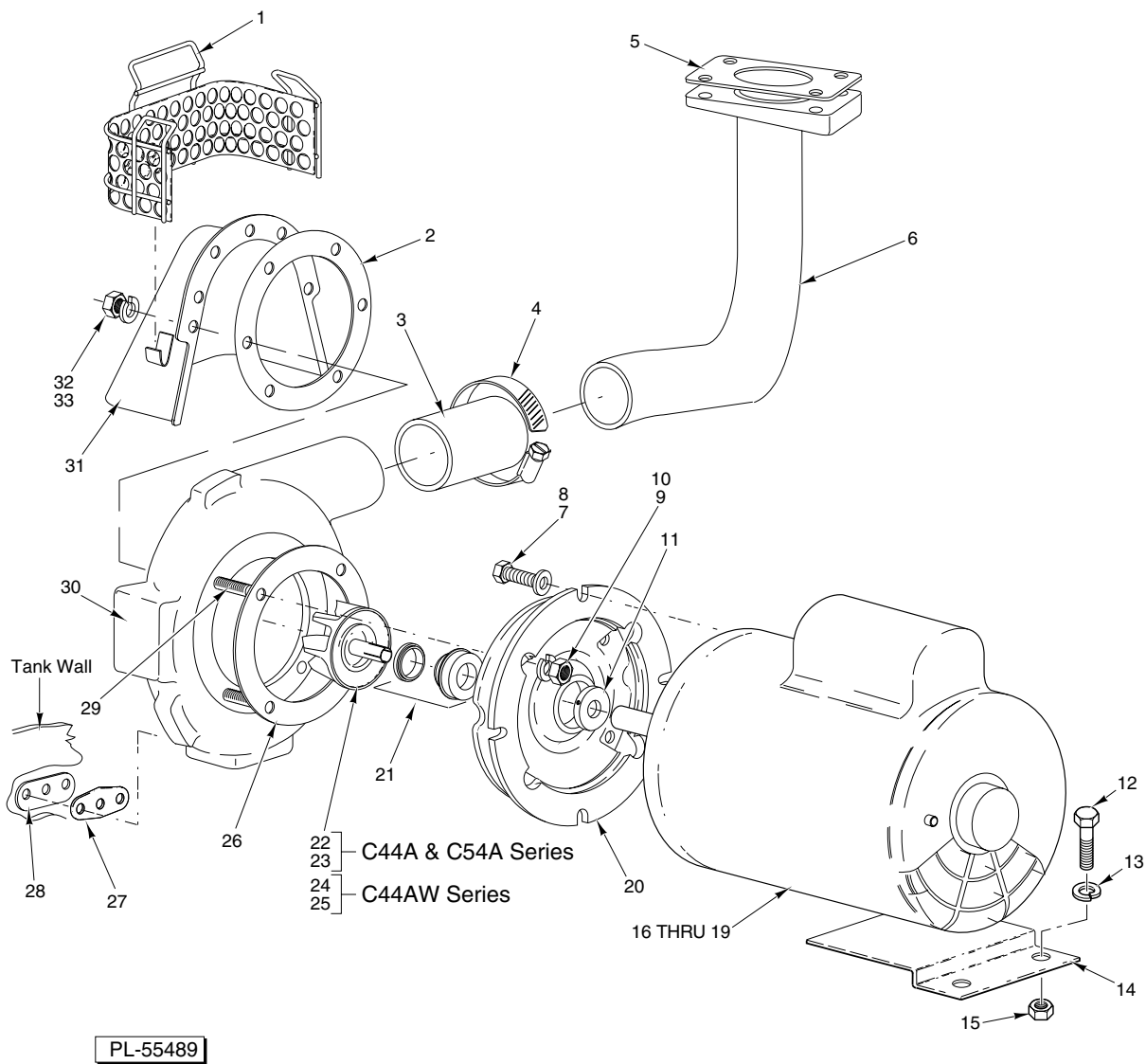

WASH MOTOR AND PUMP UNIT

vsezip.ru

+7(812)987-08-81

WASH MOTOR AND PUMP UNIT

ILLUS.	PART NO.	NAME OF PART	AMT.
PL-55489			
1	00-328362	Strainer – Pump	1
2	00-119050	Gasket	1
3	00-749586	Hose – Discharge	1
4	00-542337	Clamp – Hose	2
5	00-270968	Gasket – Wash Pipe	1
6	00-270970	Tube – Discharge	1
7	SC-041-29	Cap Screw 3/8-16 x 7/8 Hex Hd. (SST)	4
8	WS-06-44	Washer	4
9	WL-006-22	Lockwasher 5/16 Light	4
10	NS-015-11	Nut 5/16-18 Hex	4
11	00-274227-00002	Clamp	1
12	SC-041-05	Cap Screw 1/4-16 x 5/8 Hex Hd. (SST)	2
13	WL-007-16	Lockwasher 1/4	2
14	00-812069	Bracket – Motor Support	1
15	NS-015-01	Nut 1/4-20 Hex (SST)	2
16	00-274230-00001	Motor (1 Ph., 60 Hz.) (2 Hp.)	1
17	00-274230-00002	Motor (3 Ph., 60 Hz.) (2 Hp.)	1
18	00-274230-00003	Motor (1 Ph., 50 Hz.) (2 Hp.)	1
19	00-274230-00004	Motor (3 Ph., 50 Hz.) (2 Hp.)	1
20	00-274227-00003	Adapter	1
21	00-274227-00006	Seal – Shaft	1
*22	00-274227-00007	Impeller & Sleeve (60 Hz.)	1
*23	00-274227-00010	Impeller & Sleeve (50 Hz.)	1
**24	00-274227-00012	Impeller & Sleeve (60 Hz.)	1
**25	00-274227-00007	Impeller & Sleeve (60 Hz.)	1
26	00-274227-00004	Gasket	1
27	00-119051	Gasket	2
28	00-812776	Plate – Support	2
29	00-274227-00005	Stud	AR
30	00-274227-00001	Pump Shell (Incls. Items 19)	1
31	00-274246	Shroud	1
32	WL-006-23	Lockwasher 5/16 Medium (SST)	10
33	NS-015-11	Nut 5/16-18 Hex	10

* C44A & C54A Series

** C44AW Series

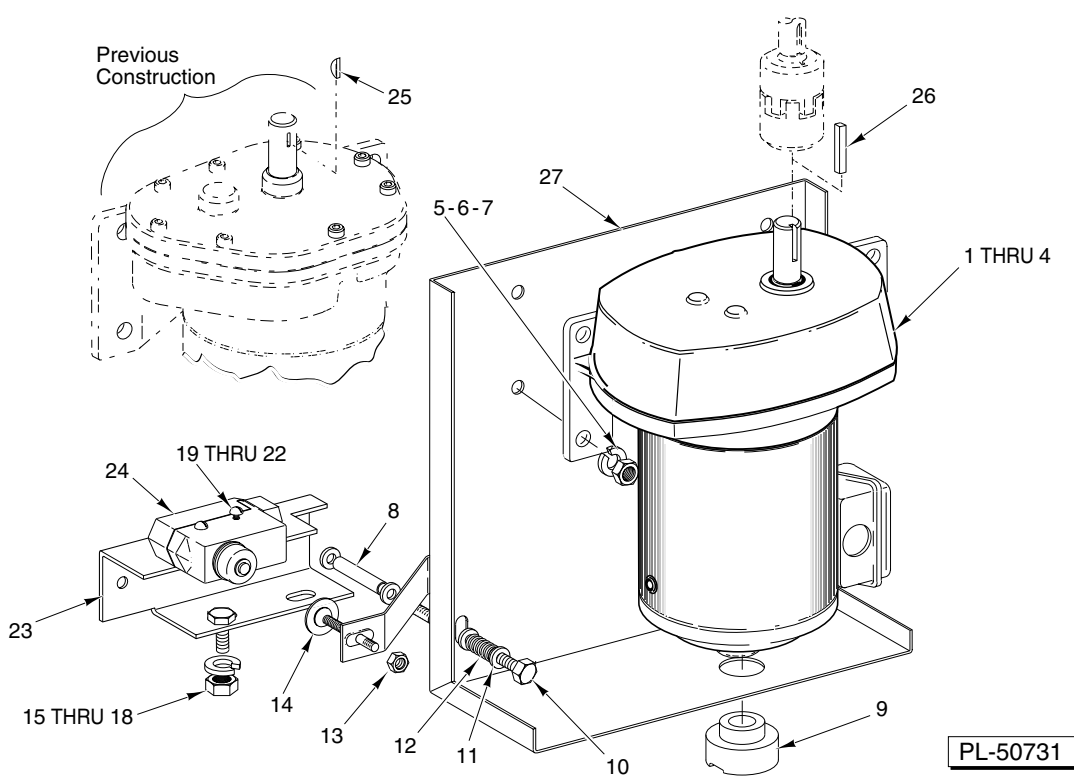

**CONVEYOR DRIVE UNIT
(C44A SERIES 1/4 Hp.)**

vsezip.ru

+7(812)987-08-81

**CONVEYOR DRIVE UNIT
(C44A SERIES 1/4 Hp.)**

ILLUS.	PART NO.	NAME OF PART	AMT.
PL-50731			
1	00-270930-00001	Motor – Conveyor Drive (208-240/480 V., 60 Hz., 3 Ph.) (Incls. Item 26)	1
2	00-270930-00002	Motor – Conveyor Drive (208-240 V., 60 Hz., 1 Ph.) (Incls. Item 26)	1
3	00-270930-00003	Motor – Conveyor Drive (200-240 V., 50 Hz., 1 Ph.) (Incls. Item 26)	1
4	00-270930-00004	Motor – Conveyor Drive (200-240/380-415 V., 50 Hz., 3 Ph.) (Incls. Item 26)	1
5	SC-041-30	Cap Screw 3/8-16 x 1 Hex Hd. (SST)	4
6	WL-006-29	Lockwasher 3/8 Hi-Collar	4
7	NS-015-13	Nut 3/8-16 Hex (SST)	4
8	00-271083	Spacer – Overload	1
9	00-270927	Pilot Bearing	1
10	SC-120-72	Cap Screw 5/16-18 x 4 1/2 Hex Hd.	1
11	WS-029-05	Washer	4
12	00-270935	Spring – Overload	1
13	NS-032-33	Stop Nut 1/4-28 Flexloc	1
14	00-289256	Actuator – Switch	1
15	SC-041-10	Cap Screw 5/16-18 x 5/8 Hex Hd.	3
16	WL-006-23	Lockwasher 5/16 Medium (SST)	3
17	NS-015-11	Nut 5/16-18 Hex	3
18	WS-029-05	Washer	1
19	SC-027-24	Mach. Screw 6-32 x 1 1/2 Rd. Hd.	2
20	WL-010-22	Lockwasher #6 External Shakeproof	2
21	WS-002-06	Washer	4
22	NS-010-06	Mach. Nut 6-32 Hex	2
23	00-270933-00001	Bracket – Anti-Jam Switch	1
24	00-087711-060-1	Switch – Interlock (Incls. Items 19, 20, 21, & 22)	1
25	00-274231-00011	Key – Woodruff #605	1
26	00-274231-00057	Key – 3/16 x 3/16 x 1 1/8 Lg. (Bison)	1
27	00-270929-00001	Bracket – Motor	1
	00-103881-00038	Lubricant – Gear Case	AR

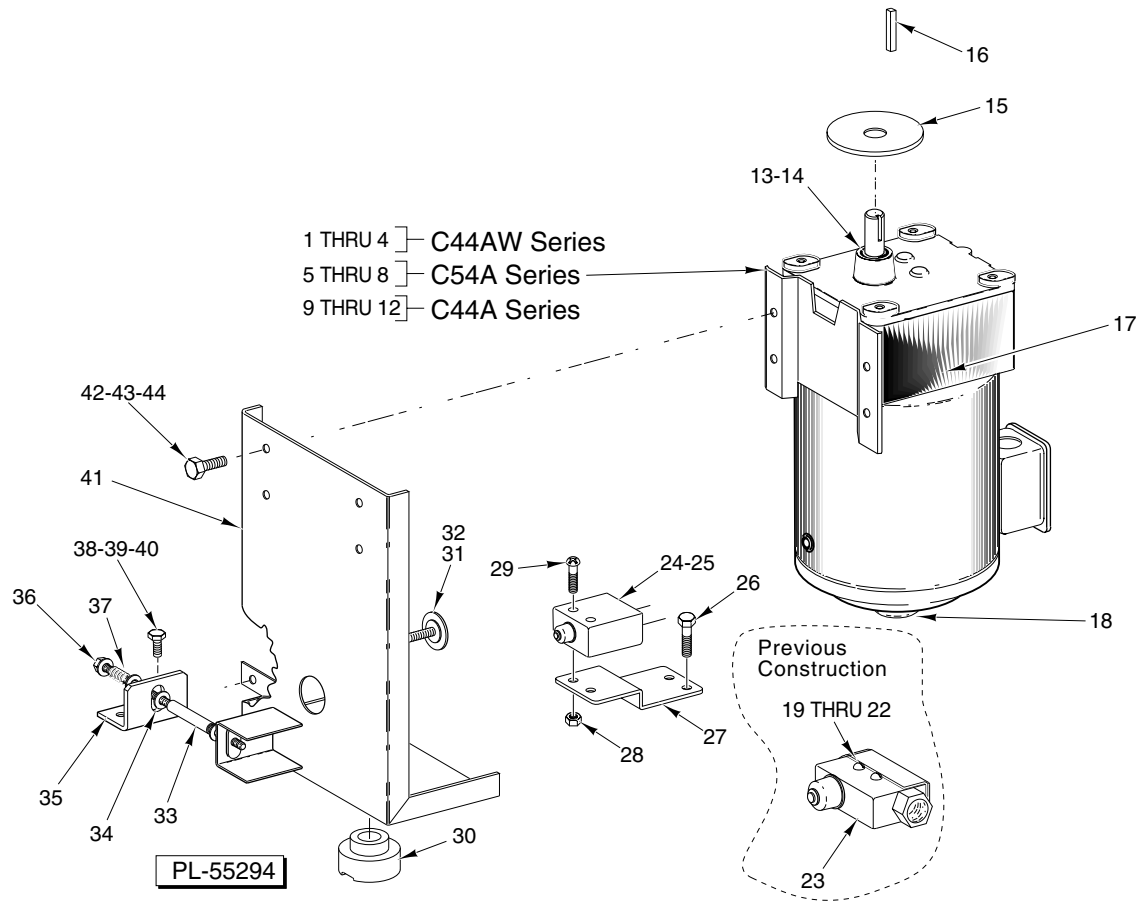

**CONVEYOR DRIVE UNIT
(C54A, C44A & AW SERIES 1/6 Hp.)**

vsezip.ru

+7(812)987-08-81

CONVEYOR DRIVE UNIT
(C54A, C44A & AW SERIES 1/6 Hp.)

ILLUS.	PART NO.	NAME OF PART	AMT.
PL-55294			
**1	00-328002-00001	Motor – Conveyor Drive (208-240/480 V., 60 Hz., 3 Ph.) (Incls. Items 27, 28, & 29)	1
**2	00-328002-00002	Motor – Conveyor Drive (208-240 V., 60 Hz., 1 Ph.) (Incls. Items 27, 28, & 29)	1
**3	00-328002-00003	Motor – Conveyor Drive (200-240 V., 50 Hz., 1 Ph.) (Incls. Items 27, 28, & 29)	1
**4	00-328002-00004	Motor – Conveyor Drive (200-240/380-415 V., 50 Hz., 3 Ph.) (Incls. Items 27 & 28)	1
***5	00-437044-00006	Motor – Conveyor Drive (208-240/480 V., 60 Hz., 3 Ph.) (Incls. Items 27, 28, & 29)	1
***6	00-437044-00007	Motor – Conveyor Drive (208-240 V., 60 Hz., 1 Ph.) (Incls. Items 27, 28, & 29)	1
***7	00-437044-00008	Motor – Conveyor Drive (200-240 V., 50 Hz., 1 Ph.) (Incls. Items 27, 28, & 29)	1
***8	00-437044-00009	Motor – Conveyor Drive (200-240/380-415 V., 50 Hz., 3 Ph.) (Incls. Items 27 & 28)	1
*9	00-437044-00001	Motor – Conveyor Drive (208-240/480 V., 60 Hz., 3 Ph.) (Incls. Items 27, 28, & 29)	1
*10	00-437044-00002	Motor – Conveyor Drive (208-240 V., 60 Hz., 1 Ph.) (Incls. Items 27, 28, & 29)	1
*11	00-437044-00003	Motor – Conveyor Drive (200-240 V., 50 Hz., 1 Ph.) (Incls. Items 27, 28, & 29)	1
*12	00-437044-00004	Motor – Conveyor Drive (200-240/380-415 V., 50 Hz., 3 Ph.) (Incls. Items 27 & 28)	1
13	00-328379-00001	Seal – Oil (Output Shaft-Shown)	1
14	00-328379-00002	Seal – Oil (Motor Drive Shaft)	1
15	00-474423	Flinger	1
16	00-274231-00057	Key – 3/16 x 3/16 x 1 1/8 Lg.	1
17	BB-005-19	Ball Bearing – Fafnir #H202PP	1
18	BB-020-18	Ball Bearing - N.D. #77503	1
19	SC-027-24	Mach. Screw 6-32 x 1 1/2 Rd. Hd.	2
20	WL-010-22	Lockwasher #6 External Shakeproof	2
21	WS-002-06	Washer	4
22	NS-010-06	Mach. Nut 6-32 Hex	2
23	00-087711-060-1	Switch – Interlock (Incls. Items 13 thru 16)	1
24	00-087711-00260	Switch – Interlock	1
25	FE-022-84	Strain Relief 1/2 NPT	1
26	SC-067-05	Mach. Screw 8-32 x 1/2 Hex Hd. (SST)	2
27	00-474488	Bracket – Switch	1
28	NS-031-16	Stop Nut 10-24 Hex (SST)	2
29	SC-127-89	Mach. Screw 10-24 x 3/4 Phil. Rd. Hd. (SST)	2
30	00-270927	Pilot Bearing	1
31	NS-032-33	Stop Nut 1/4-28 Flexloc	1
32	00-289256	Actuator – Switch	1
33	00-271083	Spacer – Overload	1
34	WS-029-05	Washer	4
35	00-436017	Bracket – Overload	1
36	SC-120-72	Cap Screw 5/16-18 x 4 1/2 Hex Hd.	1
37	00-270935	Spring – Overload	1
38	SC-041-10	Cap Screw 5/16-18 x 5/8 Hex Hd.	2
39	WL-006-23	Lockwasher 5/16 Medium (SST)	2
40	NS-015-11	Nut 5/16-18 Hex	2
41	00-328027	Bracket – Motor	1
42	SC-041-31	Cap Screw 3/8-16 x 1 1/4 Hex Hd.	4
43	WL-006-29	Lockwasher 3/8 Hi-Collar	4
44	NS-015-13	Nut 3/8-16 Hex (SST)	4

* C44A Series
** C44A Series
*** C54A Series

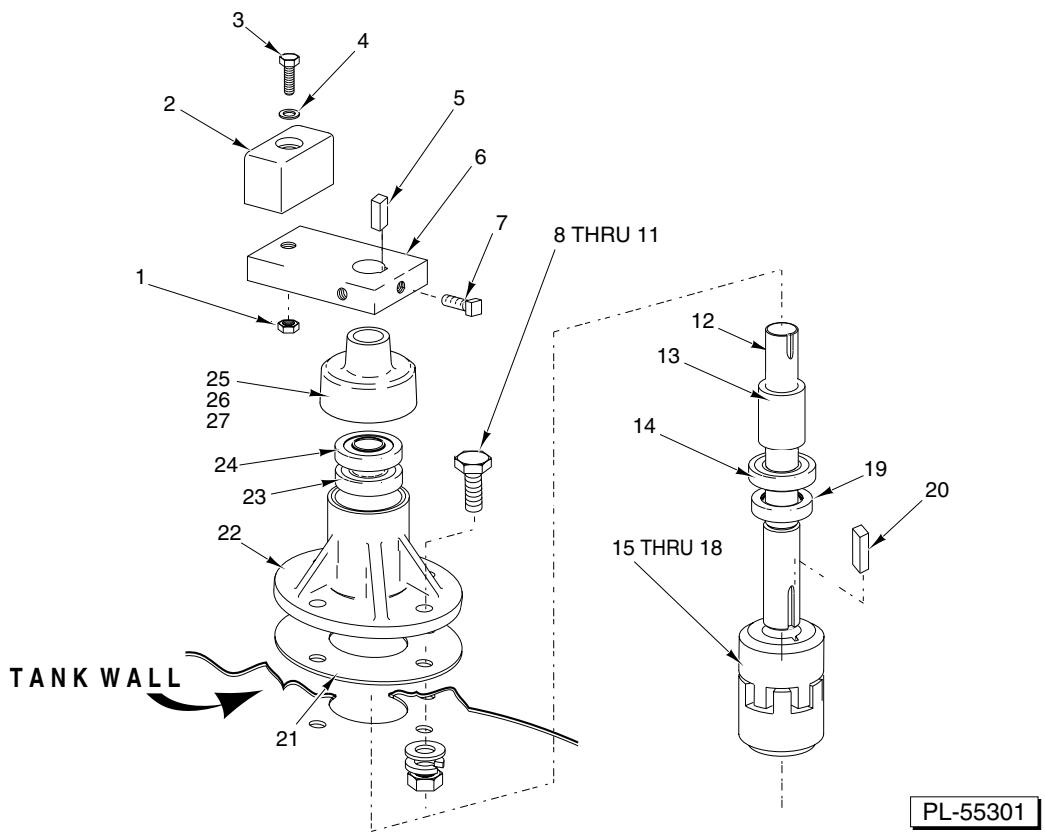

CONVEYOR DRIVE TRAIN

vsezip.ru

+7(812)987-08-81

CONVEYOR DRIVE TRAIN

ILLUS.	PART NO.	NAME OF PART	AMT.
PL-55301			
1	NS-032-35	Stop Nut ⁵ / ₁₆ -18 Flexloc	1
2	00-474660	Slide – Drive Crank	1
3	SC-041-20	Cap Screw ⁵ / ₁₆ -18 x 2 ¹ / ₈ Hex Hd.	1
4	WS-005-32	Washer	1
5	00-012430-00039	Key ³ / ₁₆ Sq. x ³ / ₈ Lg.	1
6	00-270943	Arm – Crank	1
7	SC-050-01	Set Screw ¹ / ₄ -20 x ¹ / ₂ Square Hd. Cup Pt.	2
8	SC-041-13	Cap Screw ⁵ / ₁₆ -18 x 1 Hex Hd. (SST)	4
9	WS-017-08	Washer	4
10	WL-006-23	Lockwasher ⁵ / ₁₆ Medium (SST)	4
11	NS-015-11	Nut ⁵ / ₁₆ -18 Hex	4
12	00-270937	Shaft – Crank	1
13	00-436879	Spacer – Bearing	1
14	BB-021-19	Ball Bearing – Hoover NSK 6003	1
15	00-328083	Coupling – Motor (C44AW & C54A Series) (C44A ¹ / ₆ Hp. Motor)	1
16	00-270931	Coupling – Motor (C44A Series ¹ / ₄ Hp. Motor)	1
17	00-274228-00002	Insert – Coupling Service (LoveJoy)	AR
18	00-274228-00001	Insert – Coupling Service (Browning)	AR
19	00-270939	Seal – Lower Housing	1
20	00-012430-00040	Key ³ / ₁₆ Sq. x ³ / ₄ Lg.	1
21	00-270942	Gasket	1
22	00-274749	Housing Assy. (Incls. Items 12 thru 14, 19, & 23 thru 25)	1
23	BB-021-19	Ball Bearing – Hoover NSK 6003	1
24	00-270940	Seal – Upper Housing	1
25	00-274748	Seal – Labyrinth	1
26	00-527042	Adhesive	AR
27	00-522696	Solvent	AR

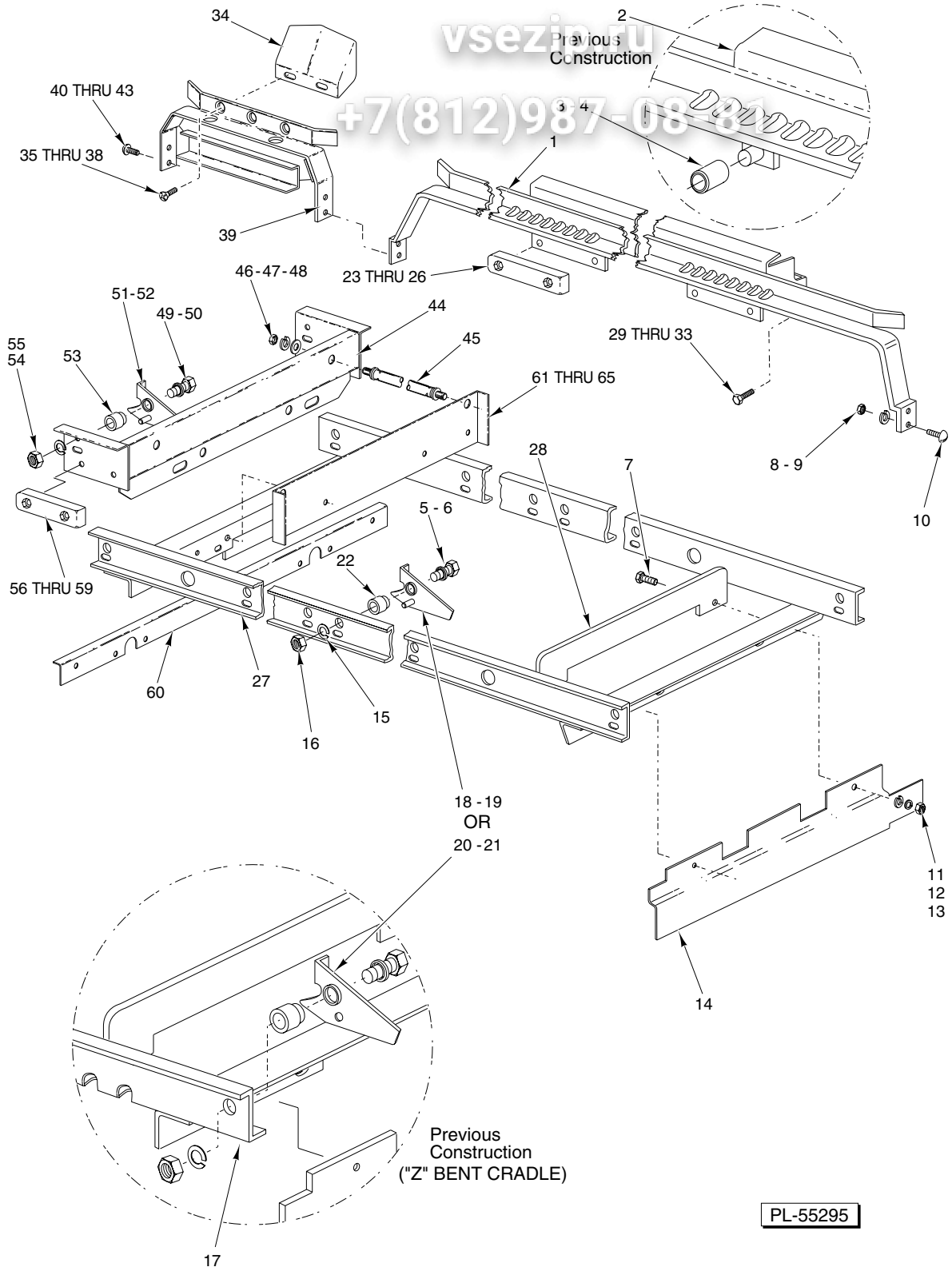

**TRACK AND CRADLE
(WASH SECTION)**

TRACK AND CRADLE
(WASH SECTION)

+7(812)987-08-81

ILLUS.	PART NO.	NAME OF PART	AMT.
	PL-55295		
1	00-436873-00001	Rack Track	2
2	-	Rack Track (Not Available) (Order *** Below)	2
3	00-270977	Roller	4
4	WS-018-04	Washer	4
*5	WS-018-04	Washer	6
*6	SC-041-31	Cap Screw ³ / ₈ -16 x 1 ¹ / ₄ Hex Hd.	6
7	SC-041-10	Cap Screw ⁵ / ₁₆ -18 x ⁵ / ₈ Hex Hd.	AR
8	NS-015-11	Nut ⁵ / ₁₆ -18 Hex	8
9	WL-006-23	Lockwasher ⁵ / ₁₆ Medium (SST)	8
10	SC-041-11	Cap Screw ⁵ / ₁₆ -18 x ³ / ₄ Hex Hd. (SST)	8
11	NS-015-11	Nut ⁵ / ₁₆ -18 Hex	AR
12	WS-017-08	Washer	AR
13	WL-006-23	Lockwasher ⁵ / ₁₆ Medium (SST)	AR
14	00-271074	Baffle – Lower (R-L Only)	1
*15	WL-006-28	Lockwasher ³ / ₈ Medium	6
*16	NS-046-09	Stop Nut ³ / ₈ -16 Elastic	6
17	-	Cradle (Not Available) (order one of the ** Below & ***; also order Item 29 & 31)	AR
*18	00-436704-00001	Dog (Front R-L) (Rear L-R)	3
*19	00-436704-00002	Dog – Not Shown (Front L-R) (Rear R-L)	3
*20	00-436703-00001	Dog (Front R-L) (Rear L-R) (Service for “Z” Bent Cradles Only)	3
*21	00-436703-00002	Dog (Front L-R) (Rear R-L) (Service for “Z” Bent Cradles Only)	3
*22	00-270983	Spacer	6
23	00-473231	Slider – Large	4
24	SC-041-14	Cap Screw ⁵ / ₁₆ -18 x 1 ¹ / ₈ Hex Hd. (SST)	8
25	WL-006-23	Lockwasher ⁵ / ₁₆ Medium (SST)	8
26	NS-015-11	Nut ⁵ / ₁₆ -18 Hex	8
27	00-436928	Cradle	1
28	00-271012	Baffle – Cradle Upper	AR
29	SC-041-13	Cap Screw ⁵ / ₁₆ -18 x 1 Hex Hd. (Mounts Front Track)	2
30	SC-041-11	Cap Screw ⁵ / ₁₆ -18 x ³ / ₄ Hex Hd. (SST)	10
31	WS-017-01	Washer	20
32	WL-006-23	Lockwasher ⁵ / ₁₆ Medium (SST)	14
33	NS-015-11	Nut ⁵ / ₁₆ -18 Hex	14
34	00-437047	Deflector – Silverware	1
35	SC-127-91	Mach. Screw ¹ / ₄ -20 x ⁵ / ₈ Flat Hd. (SST)	2
36	WS-003-47	Washer	2
37	WL-006-17	Lockwasher ¹ / ₄ Medium	2
38	NS-015-01	Nut ¹ / ₄ -20 Hex (SST)	2
39	00-328789	Rack Track (C54A)	2
40	SC-041-12	Cap Screw ⁵ / ₁₆ -18 x ⁷ / ₈ Hex Hd.	4
41	SC-041-11	Cap Screw ⁵ / ₁₆ -18 x ³ / ₄ Hex Hd. (SST)	4
42	WL-006-23	Lockwasher ⁵ / ₁₆ Medium (SST)	8
43	NS-015-11	Nut ⁵ / ₁₆ -18 Hex	8
44	00-328793	Cradle (C54A)	1
45	00-274559	Screw – Connecting (C54A)	2
46	WS-017-01	Washer	4
47	WL-006-23	Lockwasher ⁵ / ₁₆ Medium (SST)	4
48	NS-015-11	Nut ⁵ / ₁₆ -18 Hex	4
49	SC-041-31	Cap Screw ³ / ₈ -16 x 1 ¹ / ₄ Hex Hd.	2
50	WS-018-04	Washer	2
51	00-436704-00001	Dog (Front R-L) (Rear L-R) (C54A)	1
52	00-436704-00002	Dog (Front L-R) (Rear R-L) (C54A)	1
53	00-270983	Spacer	2
54	NS-046-09	Stop Nut ³ / ₈ -16 Elastic	2
55	WL-006-28	Lockwasher ³ / ₈ Medium	2
56	00-473231	Slider – Large (C54A)	2
57	SC-041-15	Cap Screw ⁵ / ₁₆ -18 x 1 ¹ / ₄ Hex Hd.	4
58	WL-006-23	Lockwasher ⁵ / ₁₆ Medium (SST)	4
59	NS-015-11	Nut ⁵ / ₁₆ -18 Hex	4
60	00-328795-00001	Support – Tank (C54A)	1
61	00-328790	Drive Bracket (C54A)	1
62	SC-041-12	Cap Screw ⁵ / ₁₆ -18 x ⁷ / ₈ Hex Hd.	4
63	WS-017-01	Washer	2
64	WL-006-23	Lockwasher ⁵ / ₁₆ Medium (SST)	4
65	NS-015-11	Nut ⁵ / ₁₆ -18 Hex	4
**	00-436927-00001	Cradle & Dog Assy. R-L (Standard Racks Only) (Incls. Items 5, 6, 15, 16, 18, 19, 22, & 27) ...	1
**	00-436927-00002	Cradle & Dog Assy. L-R (Standard Racks Only) (Incls. Items 5, 6, 15, 16, 18, 19, 22, & 27) ...	1
***	00-436968	Rack Track Assy. (Incls. Items 1 & 23 thru 26)	2
***	00-328794	Cradle & Dog Assy. (C54A) (Incls. Items 44 & 49 thru 59)	1

* Quantities listed are for 20 x 20 racks.

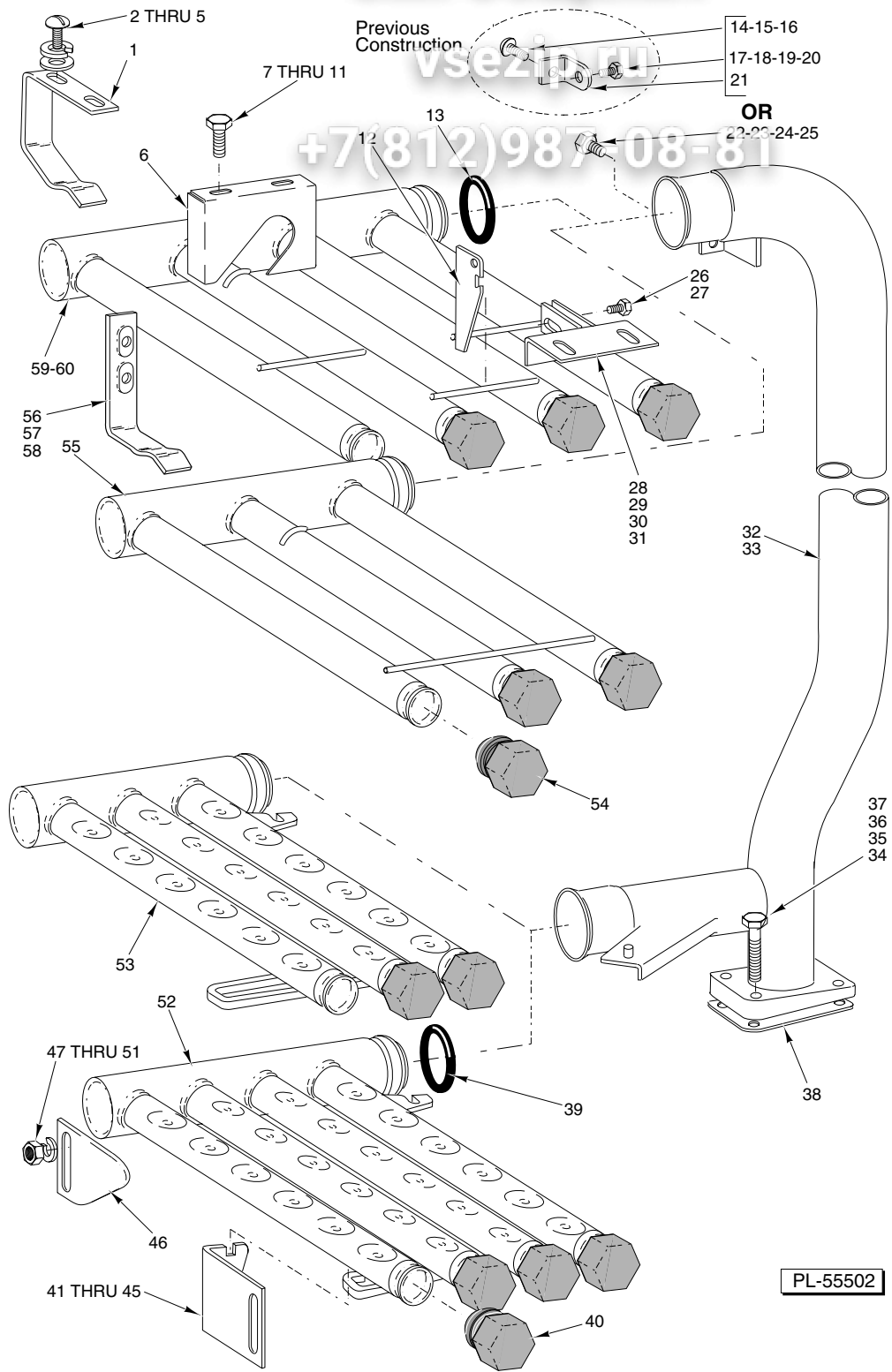

**WASH ARMS AND TUBES
(WASH SECTION – PREVIOUS CONSTRUCTION)**

**WASH ARMS AND TUBES
(WASH SECTION – PREVIOUS CONSTRUCTION)**

ILLUS. PL-55502	PART NO.	NAME OF PART	AMT.
1	00-271026	Hanger – Upper Wash Arm	AR
2	SC-053-42	Mach. Screw 1/4-20 x 5/8 Truss Hd. (SST)	AR
3	WS-022-01	Washer	AR
4	WL-006-17	Lockwasher 1/4 Medium	AR
5	NS-015-01	Nut 1/4-20 Hex (SST)	AR
6	00-271029	Guide – Upper Wash Arm	1
7	SC-041-11	Cap Screw 5/16-18 x 3/4 Hex Hd. (SST)	2
8	WS-017-01	Washer	2
9	WS-017-08	Washer	2
10	WL-006-23	Lockwasher 5/16 Medium (SST)	2
11	NS-015-11	Nut 5/16-18 Hex	2
12	00-289760	Latch	1
13	00-067500-00110	O-Ring	1
14	SC-053-42	Mach. Screw 1/4-20 x 5/8 Truss Hd. (SST)	AR
15	WL-006-17	Lockwasher 1/4 Medium	AR
16	NS-015-01	Nut 1/4-20 Hex (SST)	AR
17	SC-041-05	Cap Screw 1/4-20 x 5/8 Hex Hd. (SST)	AR
18	WS-022-01	Washer	AR
19	WL-006-17	Lockwasher 1/4 Medium	AR
20	NS-015-01	Nut 1/4-20 Hex (SST)	AR
21	00-185732	Bracket	AR
22	SC-041-01	Cap Screw 1/4-20 x 3/4 Hex Hd. (SST)	1
23	WS-022-01	Washer	2
24	WL-006-17	Lockwasher 1/4 Medium	1
25	NS-015-01	Nut 1/4-20 Hex (SST)	1
26	SC-041-09	Cap Screw 5/16-18 x 1/2 Hex Hd.	2
27	NS-031-19	Stop Nut 1/4-20 Elastic (SST)	2
28	00-271031	Bracket	1
29	WS-017-08	Washer	2
30	WL-006-23	Lockwasher 5/16 Medium (SST)	2
31	NS-015-11	Nut 5/16-18 Hex	2
32	00-274057	Wash Pipe (26 1/8 Door Height)	1
33	00-274721	Wash Pipe (32 1/8 Door Height)	1
34	SC-041-18	Cap Screw 5/16-18 x 1 3/4 Hex Hd. (SST)	4
35	WS-017-08	Washer	8
36	WL-006-23	Lockwasher 5/16 Medium (SST)	4
37	NS-015-11	Nut 5/16-18 Hex	4
38	00-270968	Gasket – Wash Pipe	1
39	00-067500-00110	O-Ring	1
40	00-435871	Plug – Wash Arm	AR
41	00-271034	Catch – Adjustable	1
42	NS-015-11	Nut 5/16-18 Hex	2
43	WL-006-23	Lockwasher 5/16 Medium (SST)	2
44	WS-017-08	Washer	2
45	SC-041-11	Cap Screw 5/16-18 x 3/4 Hex Hd. (SST)	2
46	00-274222	Support – Adjustable	1
47	SC-041-13	Cap Screw 5/16-18 x 1 Hex Hd. (AW Series)	2
48	SC-041-11	Cap Screw 5/16-18 x 3/4 Hex Hd. (SST) (A Series)	2
49	WL-006-23	Lockwasher 5/16 Medium (SST)	2
50	WS-017-08	Washer	2
51	NS-015-11	Nut 5/16-18 Hex	AR
52	00-271035	Wash Arm – Lower (A Series)	1
53	00-437065	Wash Arm – Lower (AW Series)	1
54	00-435871	Plug – Wash Arm	AR
55	00-436945	Wash Arm – Upper (R-L & L-R) (AW Series)	1
56	00-436947-00001	Hanger (AW Series)	1
57	SC-041-50	Cap Screw 1/4-20 x 1/2 Hex Hd. (AW Series)	2
58	WL-006-17	Lockwasher 1/4 Medium (AW Series)	2
59	00-271040	Wash Arm – Upper (R-L) (A Series)	1
60	00-271831	Wash Arm – Upper (L-R) (A Series)	1

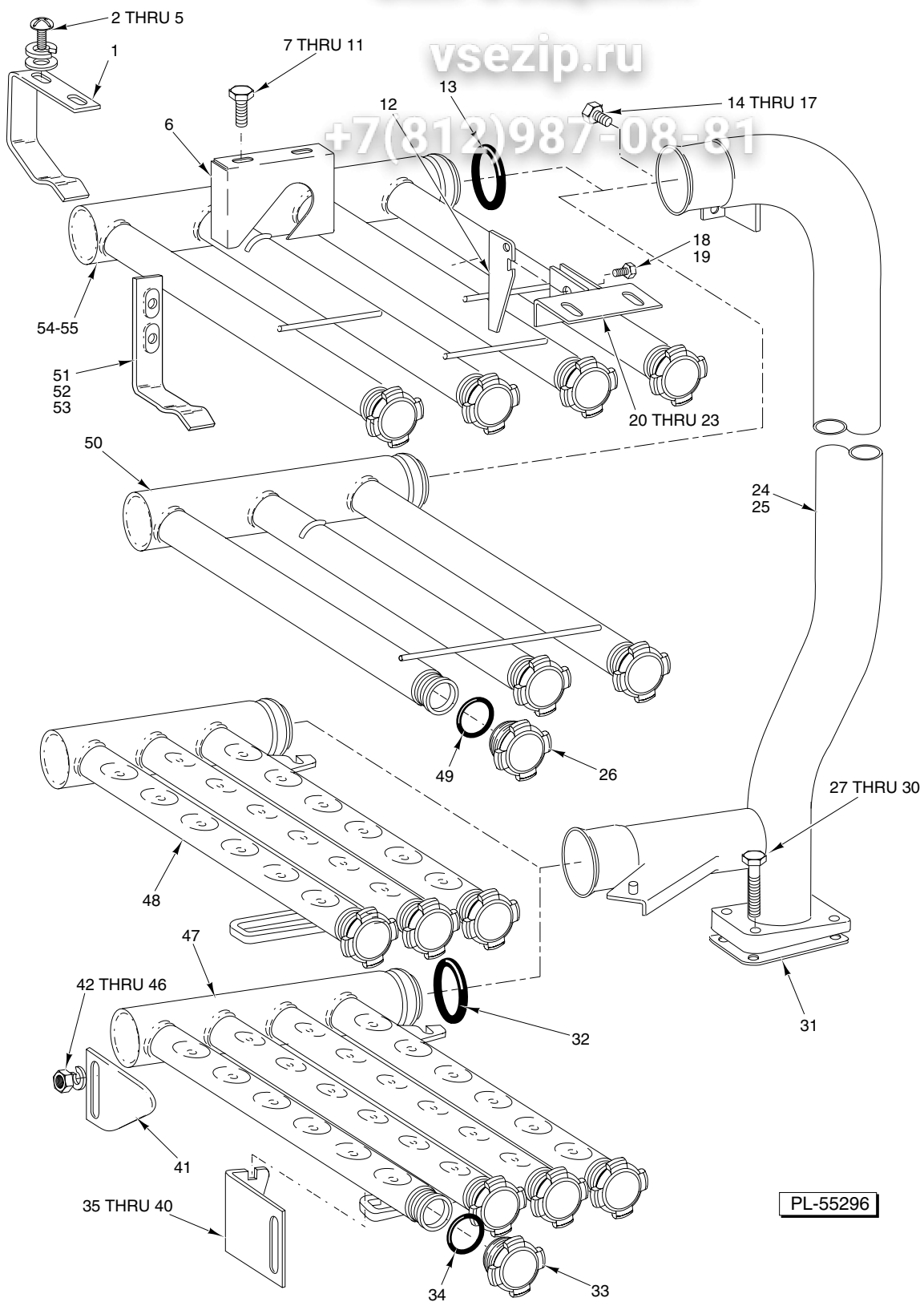

PL-55296

**WASH ARMS AND TUBES
(WASH SECTION)**

**WASH ARMS AND TUBES
(WASH SECTION)**

+7(812)987-08-81

ILLUS.	PART NO.	NAME OF PART	AMT.
	PL-55296		
1	00-271026	Hanger – Upper Wash Arm	AR
2	SC-125-85	Mach. Screw 1/4-20 x 5/8 Truss Hd. (SST)	AR
3	WS-022-01	Washer	AR
4	WL-006-17	Lockwasher 1/4 Medium	AR
5	NS-015-01	Nut 1/4-20 Hex (SST)	AR
6	00-436007	Guide – Upper Wash Arm	1
7	SC-041-11	Cap Screw 5/16-18 x 3/4 Hex Hd. (SST)	2
8	WS-017-01	Washer	2
9	WS-017-08	Washer	2
10	WL-006-23	Lockwasher 5/16 Medium (SST)	2
11	NS-015-11	Nut 5/16-18 Hex	2
12	00-289760	Latch	1
13	00-067500-00110	O-Ring	1
14	SC-041-01	Cap Screw 1/4-20 x 3/4 Hex Hd. (SST)	1
15	WS-022-01	Washer	2
16	WL-006-17	Lockwasher 1/4 Medium	1
17	NS-015-01	Nut 1/4-20 Hex (SST)	1
18	SC-041-01	Cap Screw 1/4-20 x 3/4 Hex Hd. (SST)	2
19	NS-031-19	Stop Nut 1/4-20 Elastic (SST)	2
20	00-812817	Bracket	1
21	WS-017-08	Washer	2
22	WL-006-23	Lockwasher 5/16 Medium (SST)	2
23	NS-015-11	Nut 5/16-18 Hex	2
24	00-329595	Wash Pipe (26 1/8 Door Height)	1
25	00-329597	Wash Pipe (32 1/8 Door Height)	1
26	00-475589	Plug – Wash Arm	AR
27	NS-015-11	Nut 5/16-18 Hex	4
28	WL-006-23	Lockwasher 5/16 Medium (SST)	4
29	WS-017-08	Washer	8
30	SC-041-18	Cap Screw 5/16-18 x 1 3/4 Hex Hd. (SST)	4
31	00-270968	Gasket – Wash Pipe	1
32	00-067500-00110	O-Ring	1
33	00-475589	Plug – Wash Arm	AR
34	00-067500-00127	O-Ring	AR
35	00-436939-00002	Catch – Adjustable (RH)	1
36	00-436939-00001	Catch – Adjustable (LH)	1
37	NS-015-11	Nut 5/16-18 Hex	2
38	WL-006-23	Lockwasher 5/16 Medium (SST)	2
39	WS-017-08	Washer	2
40	SC-041-11	Cap Screw 5/16-18 x 3/4 Hex Hd. (SST)	2
41	00-274222	Support – Adjustable	1
42	SC-041-13	Cap Screw 5/16-18 x 1 Hex Hd. (AW Series)	2
43	SC-041-11	Cap Screw 5/16-18 x 3/4 Hex Hd. (SST) (A Series)	2
44	WL-006-23	Lockwasher 5/16 Medium (SST)	2
45	WS-017-08	Washer	2
46	NS-015-11	Nut 5/16-18 Hex	AR
47	00-749405	Wash Arm – Lower (A Series)	1
48	00-749418	Wash Arm – Lower (AW Series)	1
49	00-067500-00127	O-Ring	AR
50	00-749419	Wash Arm – Upper (R-L & L-R) (AW Series)	1
51	00-436947-00001	Hanger (AW Series)	1
52	SC-041-50	Cap Screw 1/4-20 x 1 1/2 Hex Hd. (AW Series)	2
53	WL-006-17	Lockwasher 1/4 Medium (AW Series)	2
54	00-749406	Wash Arm – Upper (R-L) (A Series)	1
55	00-749407	Wash Arm – Upper (L-R) (A Series)	1

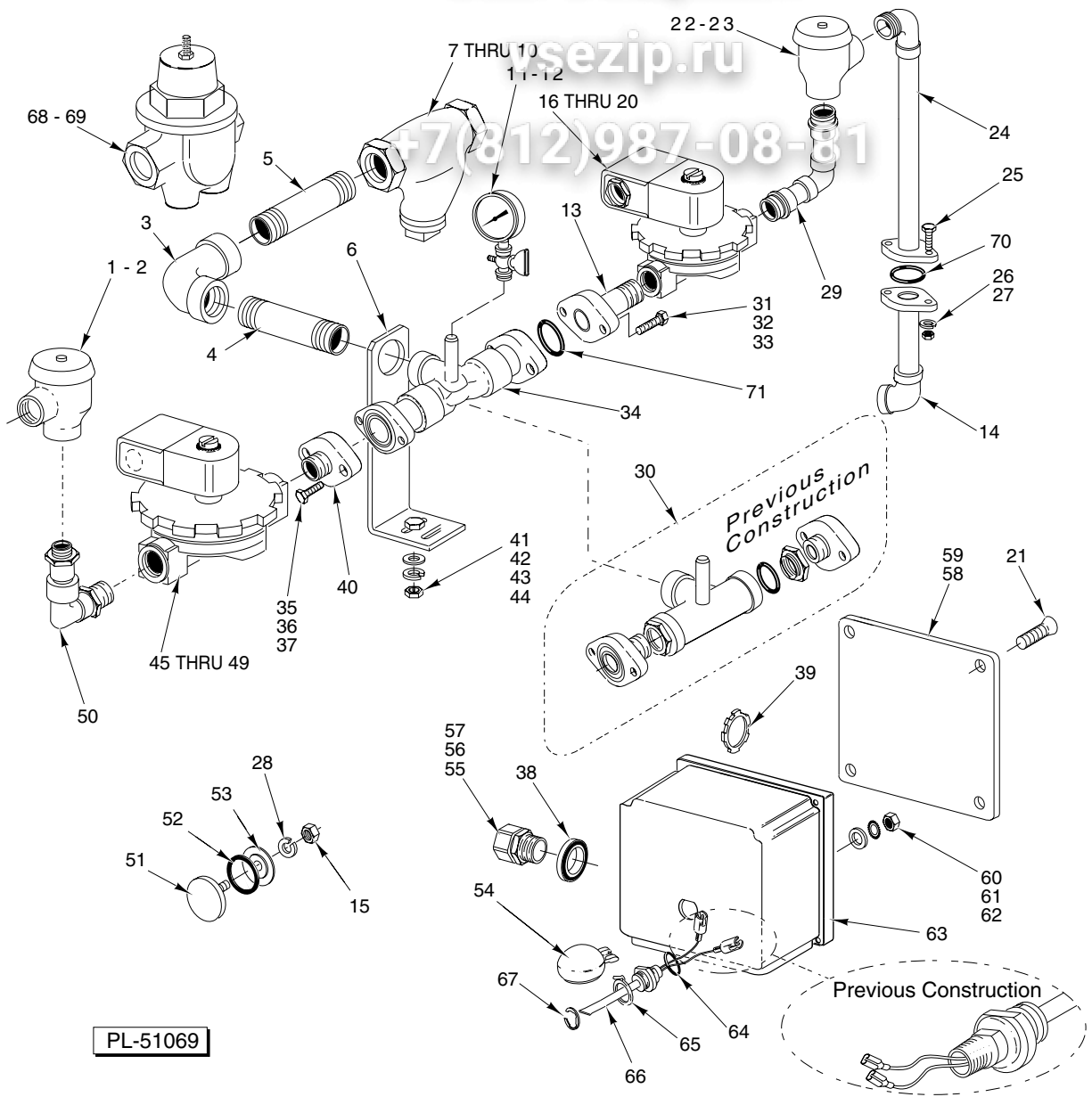

**FILL AND OUTSIDE RINSE PIPING
(PREVIOUS CONSTRUCTION)**

ILLUS.	PART NO.	NAME OF PART	AMT.
PL-51069			
1	00-277112	Vacuum Breaker (3/4)	1
2	00-118270	Service Kit – Vacuum Breaker (Float & Seal Assy.)	1
3	FP-015-23	Elbow – Pipe 3/4 x 90 Deg. (Brass)	1
4	FP-041-88	Nipple 3/4 x 5 Lg. TBE (Brass)	1
5	FP-042-12	Nipple 3/4 x 8 1/4 Lg. TBE (Brass)	1
6	00-271022	Bracket	1
7	00-186922	Line Strainer (3/4) (Incls. Items 8, 9, & 10)	1
8	00-186923	Plug – Branch	1
9	00-186924	Gasket – Branch Plug	1
10	00-186925	Screen – Line Strainer	1

FILL AND OUTSIDE RINSE PIPING (Cont.)
(PREVIOUS CONSTRUCTION)

ILLUS.	PART NO.	NAME OF PART	AMT.
	PL-51069		
11	00-328247	Gauge – Water Pressure	1
12	00-436319	Petcock 1/4	1
13	00-063262-00031	Flange & Nipple	1
14	00-271023	Piping – Inside	1
**15	NS-015-01	Nut 1/4-20 Hex (SST)	1
16	00-271006-00001	Solenoid Valve 3/8 (120 V.) (Incls. Items 18 & 20) (Fill)	1
***17	00-271006-00002	Solenoid Valve 3/8 (208-240 V.) (Incls. Items 19 & 20) (Fill)	1
18	00-271839-00001	Coil – Solenoid Valve	1
19	00-271839-00002	Coil – Solenoid Valve	1
20	00-271837	Service Kit – 1/2 Solenoid Valve	1
*21	SD-012-20	Self-Tapping Screw 8-32 x 1/2 Phil. Truss Hd., Type T	4
22	00-271008	Vacuum Breaker 3/8	1
23	00-274233	Service Kit – Vacuum Breaker	1
24	00-271007	Fill Piping – Outside	1
25	SC-041-15	Cap Screw 5/16-18 x 1 1/4 Hex Hd.	2
26	WL-006-23	Lockwasher 5/16 Medium (SST)	2
27	NS-015-11	Nut 5/16-18 Hex	2
**28	WL-006-17	Lockwasher 1/4 Medium	1
29	00-271009	Fill Piping	1
30	-	Piping – Common Connection (Not Available, Order Item 34)	1
31	SC-041-15	Cap Screw 5/16-18 x 1 1/4 Hex Hd.	2
32	WL-006-23	Lockwasher 5/16 Medium (SST)	2
33	NS-015-11	Nut 5/16-18 Hex	2
34	00-435074	Piping – Common Connection	1
35	SC-041-15	Cap Screw 5/16-18 x 1 1/4 Hex Hd.	2
36	WL-006-23	Lockwasher 5/16 Medium (SST)	2
37	NS-015-11	Nut 5/16-18 Hex	2
*38	FE-008-10	1/2 Gasket Assy.	2
*39	FE-006-07	Lock Nut 1/2 (Cnd.)	1
40	00-063262-00006	Flange & Nipple	1
41	NS-015-11	Nut 5/16-18 Hex	2
42	WL-006-23	Lockwasher 5/16 Medium (SST)	2
43	WS-029-05	Washer	2
44	SC-041-10	Cap Screw 5/16-18 x 5/8 Hex Hd.	2
45	00-271002-00001	Solenoid Valve 3/4 (120 V.) (Incls. Items 47 & 49) (Rinse)	1
***46	00-271002-00002	Solenoid Valve 3/4 (208-240 V.) (Incls. Items 48 & 49) (Rinse)	1
47	00-271839-00001	Coil – Solenoid Valve (120 V.)	1
48	00-271839-00002	Coil – Solenoid Valve (208-240 V.)	1
49	00-271838	Service Kit – 3/4 Solenoid Valve	1
50	00-271001	Piping – Final Rinse	1
**51	00-119244	Cap & Stud Assy.	1
**52	00-067500-00031	O-Ring	1
**53	00-119254	Retainer – Cap & Stud	1
*54	00-122674	Float Assy.	1
*55	FE-006-45	Connector – Straight 1/2 (Thinwall)	1
*56	FE-024-49	Connector – Straight 1/2 (Thinwall)	1
*57	FE-006-05	Lock Nut 1/2	1
*58	00-112007	Gasket	1
*59	00-288465	Lid & Gasket Assy. (Incls. Item 58)	1
*60	NS-018-28	Jam Nut 1/2-20 Hex	1
*61	WL-014-31	Lockwasher 1/2 External Shakeproof (SST)	1
*62	WS-010-40	Washer – Thrust	1
*63	00-270926	Junction Box – Auto Fill (RH) (R-L)	1
*64	00-067500-00072	O-Ring	1
*65	00-112467	Retainer – Float	1
***66	00-328486	Probe & Switch Assy. (2 Wire) (Water Level) (Incls. Items 54, 64, & 65)	1
*67	RR-010-13	Retaining Ring	1
68	00-119611	Valve – Pressure Regulating 3/4"	1
69	00-289091-00001	Kit – Service	1
70	00-067500-00012	O-Ring	1
71	00-067500-00012	O-Ring	2

* C54A, 44A, & AW.
 ** CRS76A, 66A/AW & CPW90A, 80A/AW.
 *** Used on machines W/O 120 V. pilot circuit.
 **** Must order two jumper wires, Part #328758.

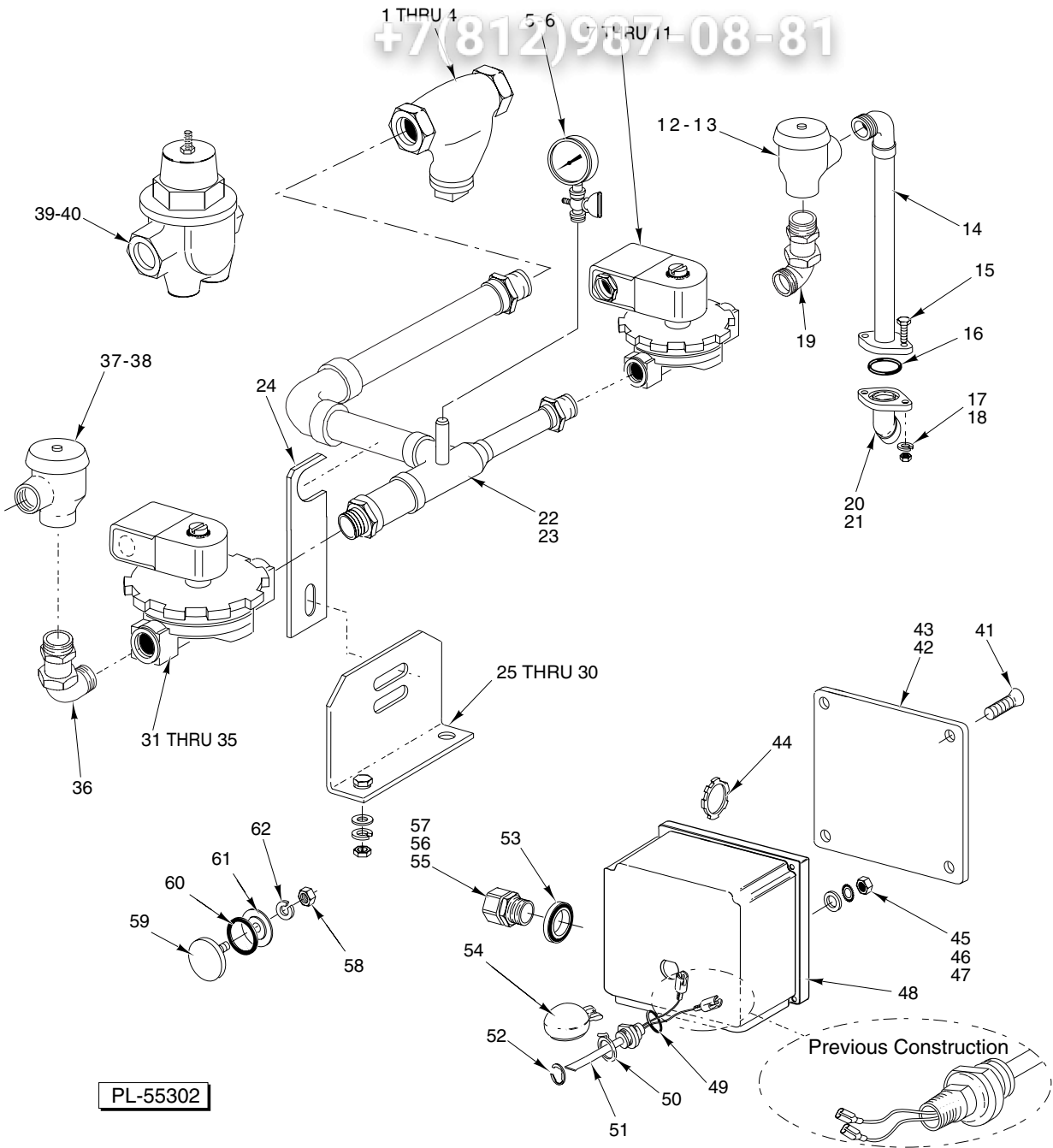

**FILL AND OUTSIDE RINSE PIPING
(CURRENT CONSTRUCTION)**

**FILL AND OUTSIDE RINSE PIPING
(CURRENT CONSTRUCTION)**

ILLUS.	PART NO.	NAME OF PART	AMT.
PL-55302			
1	00-186922	Line Strainer (3/4) (Incls. Items 2, 3, & 4)	1
2	00-186923	Plug – Branch	1
3	00-186924	Gasket – Branch Plug	1
4	00-186925	Screen – Line Strainer	1
5	00-328247	Gauge – Water Pressure	1
6	00-436319	Petcock 1/4	1
7	00-271006-00001	Solenoid Valve 3/8 (120 V.) (Incls. Items 9 & 11)	1
***8	00-271006-00002	Solenoid Valve 3/8 (208-240 V.) (Incls. Items 10 & 11)	1
9	00-271839-00001	Coil – Solenoid Valve	1
10	00-271839-00002	Coil – Solenoid Valve	1
11	00-271837	Service Kit – 1/2 Solenoid Valve	1
12	00-271008-00002	Vacuum Breaker 3/8	1
13	00-274233	Service Kit – Vacuum Breaker	1
14	00-329609	Fill Piping – Outside	1
15	SC-041-15	Cap Screw 5/16-18 x 1 1/4 Hex Hd.	2
16	00-067500-00012	O-Ring	1
17	WL-006-23	Lockwasher 5/16 Medium (SST)	2
18	NS-015-11	Nut 5/16-18 Hex	2
19	00-328765	Adapter – Elbow	1
20	00-435972-00002	Piping – Inside (RH)	1
21	00-435972-00001	Piping – Inside (LH)	1
22	00-812946-00001	Piping Sub-Assy. R-L	1
23	00-812946-00002	Piping Sub-Assy. L-R	1
24	00-435967	Plate – Fill Piping	1
25	00-435974	Bracket – Fill Piping	1
26	SC-041-12	Cap Screw 5/16-18 x 7/8 Hex Hd.	2
27	SC-041-11	Cap Screw 5/16-18 x 3/4 Hex Hd. (SST)	2
28	WS-029-05	Washer	6
29	WL-006-23	Lockwasher 5/16 Medium (SST)	4
30	NS-015-11	Nut 5/16-18 Hex	4
31	00-271002-00001	Solenoid Valve 3/4 (120 V.) (Incls. Items 33 & 35)	1
***32	00-271002-00002	Solenoid Valve 3/4 (208-240 V.) (Incls. Items 34 & 35)	1
33	00-271839-00001	Coil – Solenoid Valve	1
34	00-271839-00002	Coil – Solenoid Valve	1
35	00-271838	Service Kit – 3/4 Solenoid Valve	1
36	00-328764	Adapter Elbow 3/4 x 90 Deg.	1
37	00-277112-00003	Vacuum Breaker	1
38	00-118270	Service Kit – Vacuum Breaker (Float & Seal Assy.)	1
39	00-119611	Valve – Pressure Regulating 3/4"	1
40	00-289091-00001	Kit – Repair (Pressure Regulating Valve)	1
*41	SD-012-20	Self-Tapping Screw 8-32 x 1/2 Phil. Truss Hd., Type T	4
*42	00-288465	Lid & Gasket Assy. (Incls. Item 43)	1
*43	00-112007	Gasket	1
*44	FE-006-07	Lock Nut 1/2 (Cnd.)	1
*45	NS-018-28	Jam Nut 1/2-20 Hex	1
*46	WL-014-31	Lockwasher 1/2 External Shakeproof (SST)	1
*47	WS-010-40	Washer – Thrust	1
*48	00-270926	Junction Box – Auto Fill (RH) (R-L)	1
*49	00-067500-00072	O-Ring	1
*50	00-112467	Retainer – Float	1
****51	00-328486	Probe & Switch Assy. (Water Level) (Incls. Items 49, 50, & 54)	1
*52	RR-010-13	Retaining Ring	1
*53	FE-008-10	1/2 Gasket Assy.	2
*54	00-122674	Float Assy.	1
*55	FE-006-45	Connector – Straight 1/2 (Thinwall)	1
*56	FE-024-49	Connector – Straight 1/2 (Thinwall)	1
*57	FE-006-05	Lock Nut 1/2	1
*58	NS-015-01	Nut 1/4-20 Hex (SST)	1
**59	00-119244	Cap & Stud Assy.	1
*60	00-067500-00031	O-Ring	1
**61	00-119254	Retainer – Cap & Stud	1
**62	WL-006-17	Lockwasher 1/4 Medium	1

* C54A, 44A, & AW.
 ** CRS76A, 66A/AW & CPW90A, 80A/AW.
 *** Used on machines W/O 120 V. pilot circuit.
 **** Must order two jumper wires, Part #328758.

INSIDE METALLIC RINSE PIPING

ILLUS.	PART NO.	NAME OF PART	AMT.
	PL-55304		
1	00-271004	Final Rinse Outside Piping (R-L)	1
2	00-329610-00002	Final Rinse Outside Piping (L-R)	1
3	00-067500-00012	O-Ring	2
4	WL-006-23	Lockwasher ⁵ / ₁₆ Medium (SST)	2
5	NS-015-11	Nut ⁵ / ₁₆ -18 Hex	2
6	00-271010-00001	Final Rinse Inside Piping (R-L) (26 ¹ / ₈ Door Height) (C44A & AW)	1
7	00-271010-00002	Final Rinse Inside Piping (L-R) (26 ¹ / ₈ Door Height) (C44A & AW)	1
8	00-274707-00001	Final Rinse Inside Piping (R-L) (32 ¹ / ₈ Door Height) (C44A & AW)	1
9	00-274707-00002	Final Rinse Inside Piping (L-R) (32 ¹ / ₈ Door Height) (C44A & AW)	1
***10	00-328805-00001	Final Rinse Inside Piping (R-L) (26 ¹ / ₈ Door Height)	1
***11	00-328805-00002	Final Rinse Inside Piping (L-R) (26 ¹ / ₈ Door Height)	1
***12	00-328812-00001	Final Rinse Inside Piping (R-L) (32 ¹ / ₈ Door Height)	1
***13	00-328812-00002	Final Rinse Inside Piping (L-R) (32 ¹ / ₈ Door Height)	1
**14	00-328058-00001	Lower Rinse Arm (R-L) 6 Nozzles (Incls. Items 20, 33, & 40)	1
**15	00-328058-00002	Lower Rinse Arm (L-R) 6 Nozzles (Incls. Items 20, 33, & 40)	1
*16	00-271027-00001	Lower Rinse Arm (R-L) 5 Nozzles (Incls. Items 20, 33, & 41)	1
*17	00-271027-00002	Lower Rinse Arm (L-R) 5 Nozzles (Incls. Items 20, 33, & 41)	1
***18	00-328807-00001	Lower Rinse Arm (R-L) 5 Nozzles (Incls. Items 20, 33, & 42)	1
***19	00-328807-00002	Lower Rinse Arm (L-R) 5 Nozzles (Incls. Items 20, 33, & 42)	1
20	FP-030-27	Lock Nut ¹ / ₂ NPSL Pipe (Brass)	1
21	WL-006-23	Lockwasher ⁵ / ₁₆ Medium (SST)	1
22	FP-030-27	Lock Nut ¹ / ₂ NPSL Pipe (Brass)	1
**23	00-437063-00001	Upper Rinse Arm (R-L) 6 Nozzles (Incls. Items 22, 36, & 38)	1
**24	00-437063-00002	Upper Rinse Arm (L-R) 6 Nozzles (Incls. Items 22, 36, & 38)	1
*25	00-271088-00001	Upper Rinse Arm (R-L) 6 Nozzles (Incls. Items 22, 36, & 37)	1
*26	00-271088-00002	Upper Rinse Arm (L-R) 6 Nozzles (Incls. Items 22, 36, & 37)	1
***27	00-328808-00001	Upper Rinse Arm (R-L) 6 Nozzles (Incls. Items 22, 36, & 39)	1
***28	00-328808-00002	Upper Rinse Arm (L-R) 6 Nozzles (Incls. Items 22, 36, & 39)	1
29	SC-053-18	Mach. Screw ⁵ / ₁₆ -18 x ⁷ / ₈ Truss Hd. (SST)	2
30	00-067500-00012	O-Ring	1
31	SC-041-15	Cap Screw ⁵ / ₁₆ -18 x 1 ¹ / ₄ Hex Hd.	2
32	00-119127	Pipe Plug ¹ / ₈ Sq. Hd.	1
33	FP-029-08	Pipe Cap ¹ / ₂ (Brass)	1
34	SC-127-93	Mach. Screw ⁵ / ₁₆ -18 x ¹ / ₂ Truss Hd. (SST)	1
35	00-274058	Bracket	1
36	FP-029-08	Pipe Cap ¹ / ₂ (Brass)	1
*37	00-081812	Nozzle – Rinse (Brass) (0.078 Dia. Orifice)	6
**38	00-081812-00003	Nozzle – Rinse (Brass) (0.036 Dia. Orifice)	6
***39	00-081812-00004	Nozzles – Rinse (Brass) (0.094 Dia. Orifice)	6
**40	00-328059	Nozzle – Rinse (Brass) (0.041 Dia. Orifice)	6
*41	00-022731-00003	Nozzle – Rinse (SST) #50 Drill (0.070 Dia. Orifice)	5
***42	00-022731-00002	Nozzles – Rinse (SST) (0.093 Dia. Orifice)	5
***43	00-067500-00012	O-Ring	2
***44	00-328806	Connector – Rinse Piping	1
***45	SC-041-15	Cap Screw ⁵ / ₁₆ -18 x 1 ¹ / ₄ Hex Hd.	2
***46	WL-006-23	Lockwasher ⁵ / ₁₆ Medium (SST)	2
***47	NS-015-11	Nut ⁵ / ₁₆ -18 Hex	2
48	WL-006-23	Lockwasher ⁵ / ₁₆ Medium (SST)	2
49	NS-015-11	Nut ⁵ / ₁₆ -18 Hex	2
50	NS-015-11	Nut ⁵ / ₁₆ -18 Hex	1
51	SC-125-28	Mach. Screw 10-24 x 1 Truss Hd. (SST)	1
52	NS-031-16	Stop Nut 10-24 Hex (SST)	1
***53	00-122402-00002	Flange	1
***54	00-276407	Gasket – Rinse Pipe	1
***55	SC-127-94	Mach. Screw ⁵ / ₁₆ -18 x ⁷ / ₈ Truss Hd. (SST)	2
***56	WS-029-05	Washer	2
***57	WL-006-23	Lockwasher ⁵ / ₁₆ Medium (SST)	2
***58	NS-015-11	Nut ⁵ / ₁₆ -18 Hex	2

* C44A Series
 ** C44AW Series
 *** C54A Series

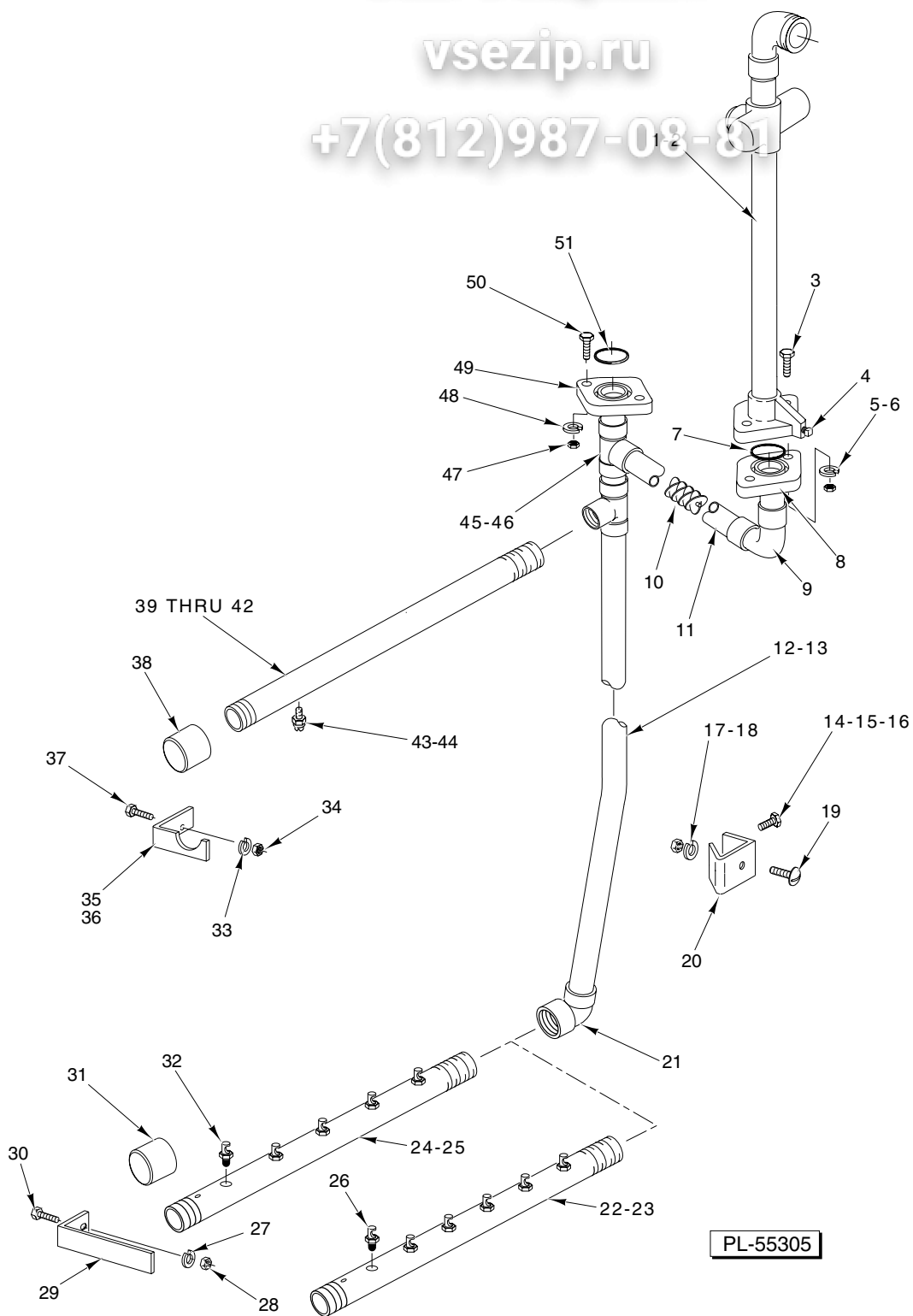

**INSIDE NON-METALLIC RINSE PIPING
(C44A AND AW SERIES)**

vsezip.ru

7(812)987-08-81
INSIDE NON-METALLIC RINSE PIPING - 81
(C44A AND AW SERIES)

ILLUS. PL-55305	PART NO.	NAME OF PART	AMT.
1	00-329608-00001	Final Outside Rinse Piping (R-L)	1
2	00-329608-00002	Final Outside Rinse Piping (L-R)	1
3	SC-041-15	Cap Screw ⁵ / ₁₆ -18 x 1 ¹ / ₄ Hex Hd.	2
4	00-119127	Pipe Plug ¹ / ₈ Sq. Hd.	2
5	WL-006-23	Lockwasher ⁵ / ₁₆ Medium (SST)	2
6	NS-015-11	Nut ⁵ / ₁₆ -18 Hex	2
7	00-067500-00012	O-Ring	2
8	00-274533	Flange	1
9	00-185781	Elbow – ¹ / ₂ " x 90 Deg. (PVC)	1
10	00-435070	Mixer – Spiral	1
11	00-274531-00001	Tube – Inside Rinse (6 ¹ / ₈ Lg.)	1
12	00-274708	Tube – Inside Rinse (32 ¹ / ₈ Door Height)	1
13	00-274536	Tube – Inside Rinse (26 ¹ / ₈ Door Height)	1
14	SC-053-50	Mach. Screw 10-24 x 1 ¹ / ₂ Truss Hd. (SST)	1
15	WL-006-07	Lockwasher #10 Medium	1
16	NS-011-18	Mach. Nut 10-24 Hex (SST)	1
17	NS-015-11	Nut ⁵ / ₁₆ -18 Hex	1
18	WL-006-23	Lockwasher ⁵ / ₁₆ Medium (SST)	1
19	SC-053-15	Mach. Screw ⁵ / ₁₆ -18 x ¹ / ₂ Truss Hd. (SST)	1
20	00-274058	Bracket	1
21	00-185781	Elbow – ¹ / ₂ " x 90 Deg. (PVC)	1
22	00-436355	Lower Rinse Arm (R-L) 6 Nozzles – C44AW (Incls. Items 19 & 26)	1
23	00-436355-00002	Lower Rinse Arm (L-R) 6 Nozzles – C44AW (Incls. Items 19 & 26)	1
24	00-274534	Lower Rinse Arm (R-L) 5 Nozzles – C44A (Incls. Items 26 & 27)	1
25	00-274534-00002	Lower Rinse Arm (L-R) 5 Nozzles – C44A (Incls. Items 26 & 27)	1
26	00-328059-00002	Nozzle – Rinse (SST)	6
27	WL-006-16	Lockwasher ¹ / ₄ Light	2
28	NS-015-01	Nut ¹ / ₄ -20 Hex (SST)	2
29	00-274570	Bracket	1
30	SC-128-05	Mach. Screw ¹ / ₄ -20 x ¹ / ₂ Fil. Hd. (SST)	2
31	00-276380-00002	Cap – Lower Rinse Arm	1
32	00-022731-00006	Nozzle – Rinse (SST) (0.035 Dia. Orifice)	5
33	WL-006-16	Lockwasher ¹ / ₄ Light	2
34	NS-015-01	Nut ¹ / ₄ -20 Hex (SST)	2
35	00-274532-00001	Bracket (R-L)	1
36	00-274532-00002	Bracket (L-R)	1
37	SC-024-06	Mach. Screw ¹ / ₄ -20 x ¹ / ₂ Fil. Hd. (SST)	2
38	00-276380-00002	Cap – Lower Rinse Arm	1
39	00-274535	Upper Rinse Arm (R-L) 6 Nozzles – C44A (Incls. Items 28 & 35)	1
40	00-274535-00002	Upper Rinse Arm (L-R) 6 Nozzles – C44A (Incls. Items 28 & 35)	1
41	00-436356	Upper Rinse Arm (R-L) 6 Nozzles – C44AW (Incls. Items 29 & 35)	1
42	00-436356-00002	Upper Rinse Arm (L-R) 6 Nozzles – C44AW (Incls. Items 29 & 35)	1
43	00-081812-00002	Nozzle – Rinse (SST) (0.078 Dia. Orifice)	6
44	00-081812-00006	Nozzle – Rinse (SST) (0.036 Dia. Orifice)	6
45	FP-085-51	Tee ¹ / ₂ x ¹ / ₂ x ¹ / ₂ NPT Schedule 80 PVC	2
46	00-274531-00002	Tube (1 ¹ / ₄ Lg.)	1
47	NS-015-11	Nut ⁵ / ₁₆ -18 Hex	2
48	WL-006-23	Lockwasher ⁵ / ₁₆ Medium (SST)	2
49	00-274533	Flange	1
50	SC-053-18	Mach. Screw ⁵ / ₁₆ -18 x ⁷ / ₈ Truss Hd. (SST)	2
51	00-067500-00012	O-Ring	1

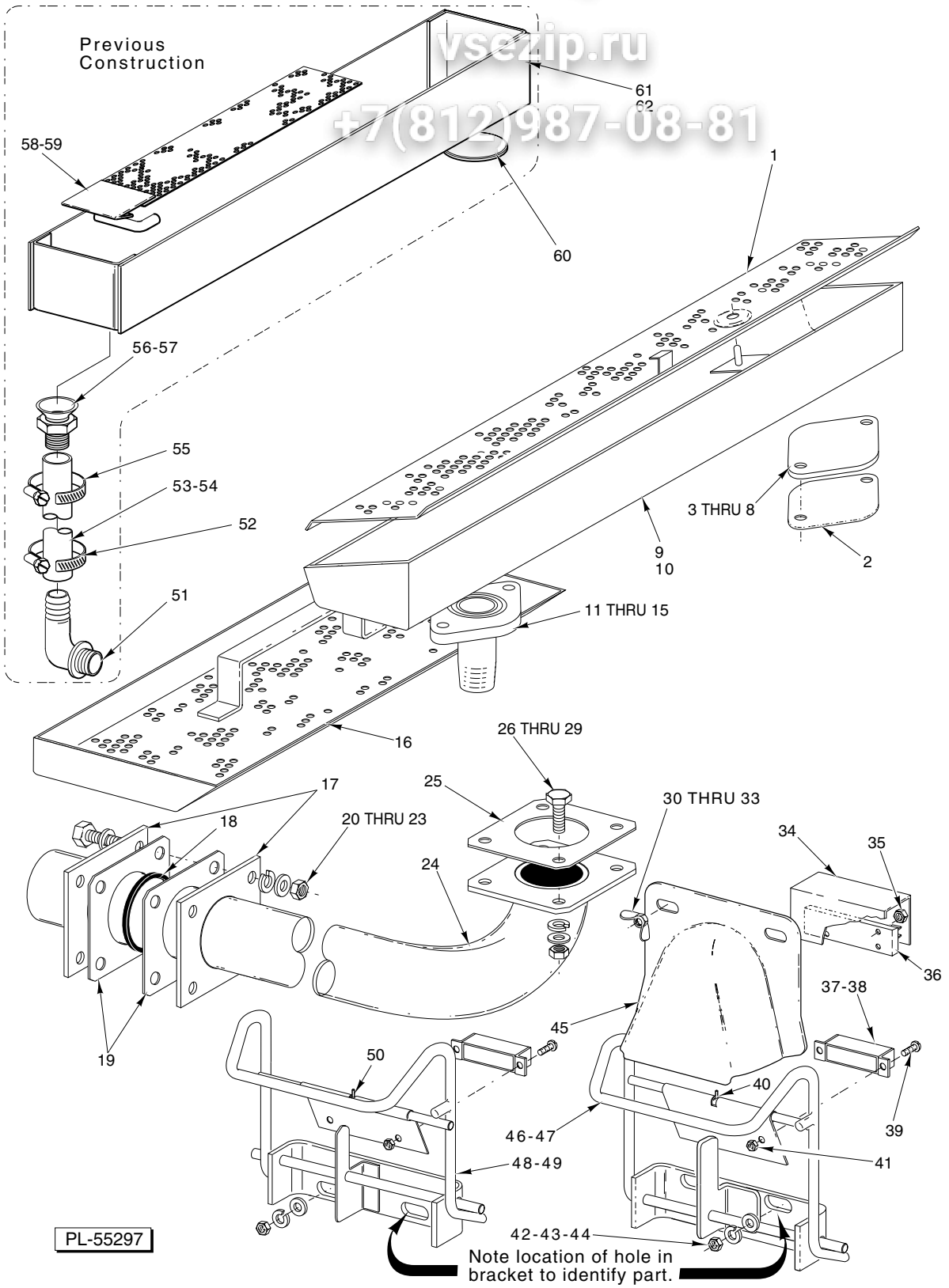

ACTUATOR MECHANISM AND RINSE DRAIN-OFF PAN

**ACTUATOR MECHANISM AND
RINSE DRAIN-OFF PAN**

ILLUS.	PART NO.	NAME OF PART	AMT.
	PL-55297		
1	00-812922-00001	Strainer	1
2	00-276407	Gasket – Rinse Pipe	1
3	00-122402-00002	Flange	1
4	SC-041-12	Cap Screw ⁵ / ₁₆ -18 x ⁷ / ₈ Hex Hd.	2
5	WS-029-05	Washer	2
6	WL-006-23	Lockwasher ⁵ / ₁₆ Medium (SST)	2
7	NS-015-11	Nut ⁵ / ₁₆ -18 Hex	2
8	00-545595	Sealer (¹ / ₈ Rd.)	AR
9	00-436828-00002	Rinse Pan Assy. (R-L)	1
10	00-436828-00001	Rinse Pan Assy. (L-R)	1
11	00-328326	Flange & Nipple Assy.	1
12	00-475056	Flange & Nipple Assy. – 1"	1
13	00-436827	Gasket	1
14	WL-006-23	Lockwasher ⁵ / ₁₆ Medium (SST)	2
15	NS-015-11	Nut ⁵ / ₁₆ -18 Hex	2
16	00-328803	Pan Rinse (C54A)	2
17	00-120115	Retainer – Seal	2
18	00-077621-00002	Ring – Sealing	1
19	00-120603	Gasket – Seal Retainer	2
20	NS-015-11	Nut ⁵ / ₁₆ -18 Hex	4
21	SC-041-15	Cap Screw ⁵ / ₁₆ -18 x 1 ¹ / ₄ Hex Hd.	4
22	WS-017-08	Washer	8
23	WL-006-23	Lockwasher ⁵ / ₁₆ Medium (SST)	4
24	00-328798	Flowback Pipe (C54A)	1
25	00-120603	Gasket – Seal Retainer	1
26	SC-041-11	Cap Screw ⁵ / ₁₆ -18 x ³ / ₄ Hex Hd. (SST)	4
27	WS-017-08	Washer	8
28	WL-006-23	Lockwasher ⁵ / ₁₆ Medium (SST)	4
29	NS-015-11	Nut ⁵ / ₁₆ -18 Hex	4
*30	NS-029-01	Wing Nut ¹ / ₄ -20	2
*31	WL-006-17	Lockwasher ¹ / ₄ Medium	2
*32	WS-017-06	Washer	2
*33	SC-053-42	Mach. Screw ¹ / ₄ -20 x ⁵ / ₈ Truss Hd. (SST)	AR
*34	00-270996	Insulator – Switch	1
*35	NS-031-50	Stop Nut 6-32 Hex (SST)	2
*36	00-749347	Switch – Reed Encapsulated	1
*37	00-290160	Magnet (Dot Toward Switch)	1
*38	00-290159	Retainer – Magnet	1
*39	SC-127-26	Mach. Screw 6-32 x ³ / ₈ Rd. Hd. (SST)	2
*40	PC-005-07	Cotter Pin ³ / ₃₂ x ¹ / ₂	1
*41	NS-031-50	Stop Nut 6-32 Hex (SST)	2
*42	WL-006-23	Lockwasher ⁵ / ₁₆ Medium (SST)	2
*43	WS-017-08	Washer	2
*44	NS-015-11	Nut ⁵ / ₁₆ -18 Hex	2
*45	00-436835	Shroud	1
46	00-435808	Actuator (C44A/AW & C54A, Front L-R; RS & PW, Rear R-L) (Previous Construction)	AR
47	00-435809	Actuator (C44A/AW & C54A, Front R-L; RS & PW, Rear L-R) (Previous Construction)	AR
48	00-436955	Actuator (C44A/AW & C54A, R-L) (Current Construction)	1
49	00-436027	Actuator (C44A/AW & C54A, L-R) (Current Construction)	1
50	PC-005-07	Cotter Pin ³ / ₃₂ x ¹ / ₂	1
51	FP-085-06	Elbow ³ / ₄ Hose Male to ³ / ₄ Male Pipe Thd. (PVC)	1
52	00-534177	Clamp – Hose #12	1
53	00-271013-00002	Hose – Drain (L-R)	1
54	00-271013-00001	Hose – Drain (R-L)	1
55	00-534177	Clamp – Hose #12	1
56	00-270948	Final Rinse Fitting	1
57	00-270949	Spacer – Final Rinse Fitting	1
58	00-271077	Strainer (L-R)	1
59	00-274258	Strainer (R-L)	1
60	FE-024-31	Cover – Electric Box	1
61	00-274256	Rinse Pan Assy. (R-L)	1
62	00-271843	Rinse Pan Assy. (L-R)	1

* Quantities are listed for one mechanism. Quantities will vary with machine type and side loader option.

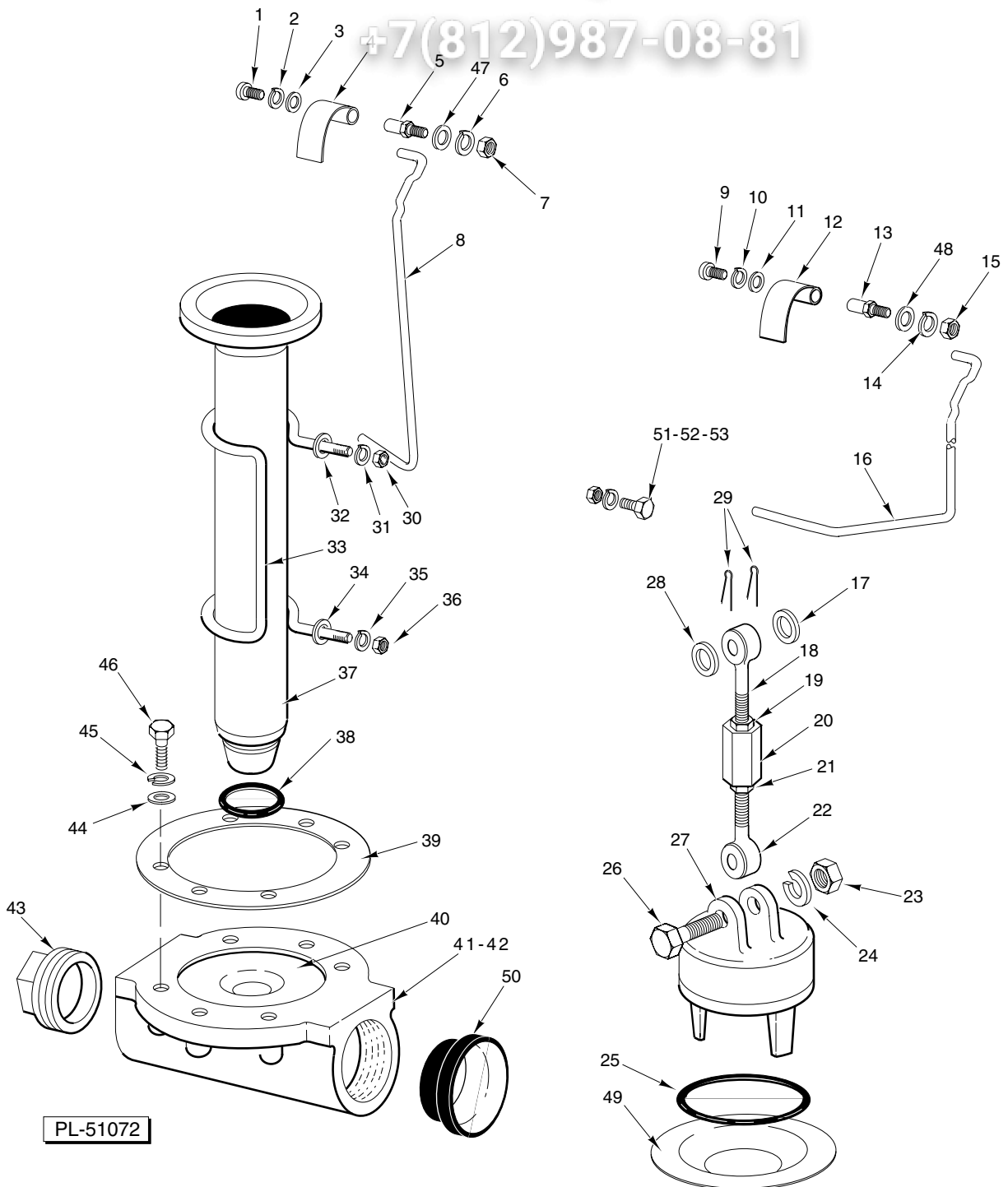

**DRAIN UNIT
(WASH SECTION)**

vsezip.ru
DRAIN UNIT
(WASH SECTION)
 +7(812)987-08-81
 NAME OF PART

ILLUS.	PART NO.	NAME OF PART	AMT.
	PL-51072		
1	SC-021-22	Mach. Screw 10-24 x 3/8 Rd. Hd. (SST)	1
2	WL-006-07	Lockwasher #10 Medium	1
3	WS-023-34	Washer	1
4	00-271070	Drain Lever (L-R)	1
5	00-119116	Axle – Drain Lever	1
6	WL-006-17	Lockwasher 1/4 Medium	1
7	NS-015-01	Nut 1/4-20 Hex (SST)	1
8	00-270953	Lift Rod Overflow	1
*	SC-021-22	Mach. Screw 10-24 x 3/8 Rd. Hd. (SST)	1
*10	WL-006-07	Lockwasher #10 Medium	1
*11	WS-023-34	Washer	1
*12	00-271070	Drain Lever (L-R)	1
*13	00-119116	Axle – Drain Lever	1
*14	WL-006-17	Lockwasher 1/4 Medium	1
*15	NS-015-01	Nut 1/4-20 Hex (SST)	1
*16	00-274147	Lift Rod – Drain	1
*17	WS-017-08	Washer	1
*18	00-079410	Pull Rod Assy. – Upper	1
*19	NS-018-06	Jam Nut 5/16-18 Hex	1
*20	00-016269	Nut – Pull Rod Adjustor	1
*21	NS-018-06	Jam Nut 5/16-18 Hex	1
*22	00-289519	Pull Rod Assy. – Lower	1
*23	NS-015-11	Nut 5/16-18 Hex	1
*24	WL-006-23	Lockwasher 5/16 Medium (SST)	1
*25	00-067500-00118	O-Ring	1
*26	SC-041-17	Cap Screw 5/16-18 x 1 1/2 Hex Hd. (SST)	1
*27	00-077466	Plug – Drain	1
*28	WS-017-08	Washer	1
*29	PC-005-02	Cotter Pin 1/16 x 1/2 (SST)	2
30	NS-015-11	Nut 5/16-18 Hex	2
31	WL-006-23	Lockwasher 5/16 Medium (SST)	1
32	WS-017-01	Washer	2
33	00-270952	Retainer	1
34	WS-017-01	Washer	2
35	WL-006-23	Lockwasher 5/16 Medium (SST)	1
36	NS-015-11	Nut 5/16-18 Hex	2
37	00-119099-00002	Tube – Overflow	1
38	00-067500-00120	O-Ring	1
39	00-289464	Gasket – Drain	1
40	00-270947	Sleeve – Drain Body	1
41	00-289465	Drain Body	1
42	00-270946	Drain Body (With 3/4-14 FPT Port on Side)	1
43	FP-028-32	Pipe Plug 2 Sq. Hd.	1
44	WS-006-44	Washer	6
45	WL-006-28	Lockwasher 3/8 Medium	6
46	SC-041-30	Cap Screw 3/8-16 x 1 Hex Hd. (SST)	6
47	WS-022-01	Washer	1
*48	WS-022-01	Washer	1
*49	00-106283	Sleeve – Drain Valve Body	1
50	00-328813	Bushing – Drain	1
*51	SC-041-10	Cap Screw 5/16-18 x 5/8 Hex Hd.	2
*52	WL-006-23	Lockwasher 5/16 Medium (SST)	2
*53	NS-015-11	Nut 5/16-18 Hex	2

* Use in wash on machines with RS or PW.

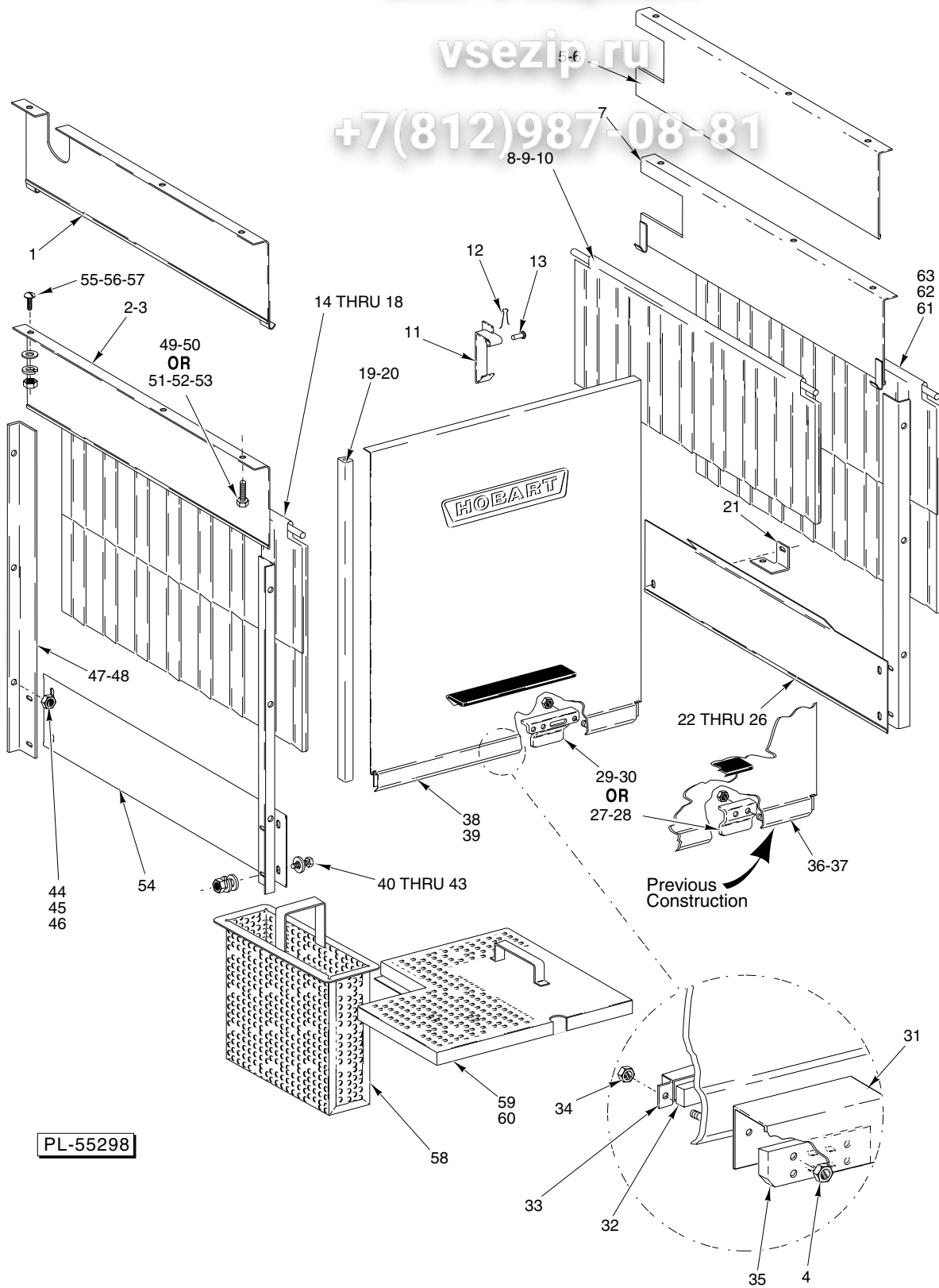

**DOOR, CURTAINS, BAFFLES,
AND STRAINERS**

DOOR, CURTAINS, BAFFLES,
AND STRAINERS

ILLUS.	PART NO.	NAME OF PART	AMT.
		+7(812)987-08-81	
1	00-271043-00001	Baffle – Unloading (R-L)	1
2	00-271048	Baffle – Loading (L-R Steam or Electric Heat, C44A Series)	1
3	00-271048-00002	Baffle – Loading (L-R Gas Heat, C44A Series) (L-R, C44AW, & C54A Series)	1
4	NS-031-50	Stop Nut 6-32 Hex (SST)	2
5	00-271046	Baffle – Loading (R-L Steam or Electric Heat, C44A Series)	1
6	00-271046-00002	Baffle – Loading (R-L Gas Heat, C44A Series) (R-L, C44AW, & C54A Series)	1
7	00-271047-00001	Baffle – Unloading (L-R)	1
8	00-120151-00001	Splash Curtain (10-C1)	AR
9	00-120151-00001	Splash Curtain (10-C1) (Gas Heat, C44A Series or All Heats, C54A, & C44AW Series)	1
10	00-120266-00001	Curtain Rod	AR
11	00-185864	Catch – Door	1
12	PC-005-02	Cotter Pin 1/16 x 1/2 (SST)	1
13	00-012114	Pin	1
14	00-271084	Splash Curtain (26 1/8 Door Height)	2
15	00-271084-00002	Splash Curtain (32 1/8 Door Height)	2
16	00-120266-00001	Curtain Rod	2
17	00-120152-00055	Splash Curtain Assy. (Incls. Items 14 & 16) (26 1/8 Door Height)	AR
18	00-120152-00056	Splash Curtain Assy. (Incls. Items 15 & 16) (32 1/8 Door Height)	AR
19	00-112378-00049	Door Slide (26 1/8 Door Height)	2
20	00-112378-00050	Door Slide (32 1/8 Door Height)	2
21	00-271834	Bracket	1
22	00-271833	Baffle – RH Lower (L-R Operation)	1
23	SC-041-05	Cap Screw 1/4-20 x 5/8 Hex Hd. (SST)	3
24	WL-006-17	Lockwasher 1/4 Medium	3
25	WS-017-06	Washer	6
26	NS-015-01	Nut 1/4-20 Hex (SST)	3
27	00-328065	Actuator – Lift Drain	1
28	NS-031-21	Stop Nut – Special 1/4-20 Hex	2
29	00-328065	Actuator – Lift Drain	1
30	NS-031-21	Stop Nut – Special 1/4-20 Hex	2
31	00-270996	Insulator – Switch	1
32	00-290160	Magnet	1
33	00-290159	Retainer – Magnet	1
34	NS-031-50	Stop Nut 6-32 Hex (SST)	2
35	00-749347	Switch – Reed Encapsulated	1
*36	-	Door (26 1/8)	1
*37	-	Door (32 1/8)	1
38	00-328064-00007	Door (26 1/8)	1
39	00-328079-00007	Door (32 1/8)	1
40	SC-041-05	Cap Screw 1/4-20 x 5/8 Hex Hd. (SST)	4
41	WS-017-06	Washer	8
42	WL-006-17	Lockwasher 1/4 Medium	4
43	NS-015-01	Nut 1/4-20 Hex (SST)	4
44	WS-022-01	Washer	9
45	WL-006-17	Lockwasher 1/4 Medium	9
46	NS-015-01	Nut 1/4-20 Hex (SST)	9
47	00-271049-00001	Baffle – Vertical (26-1/8 Door Height)	3
48	00-274720-00001	Baffle – Vertical (32-1/8 Door Height)	3
49	WL-006-17	Lockwasher 1/4 Medium	4
50	SC-041-50	Cap Screw 1/4-20 x 1/2 Hex Hd.	4
51	WS-022-01	Washer	4
52	WL-006-17	Lockwasher 1/4 Medium	4
53	NS-015-01	Nut 1/4-20 Hex (SST)	4
54	00-271832	Baffle – LH Lower	1
55	SC-053-41	Mach. Screw 1/4-20 x 1/2 Truss Hd. (SST)	2
56	WL-006-17	Lockwasher 1/4 Medium	2
57	NS-015-01	Nut 1/4-20 Hex (SST)	2
58	00-271100	Bucket – Strainer	1
59	00-271845	Strainer – Front	1
60	00-271847	Strainer – Rear (Not Shown)	1
61	00-271084	Splash Curtain (26 1/8 Door Height) (C54A)	1
62	00-271084-00002	Splash Curtain (32 1/8 Door Height) (C54A)	1
63	00-120266-00001	Curtain Rod	1

* No longer available. Order either Item 38 or 39 & Item 29 to convert to present style.

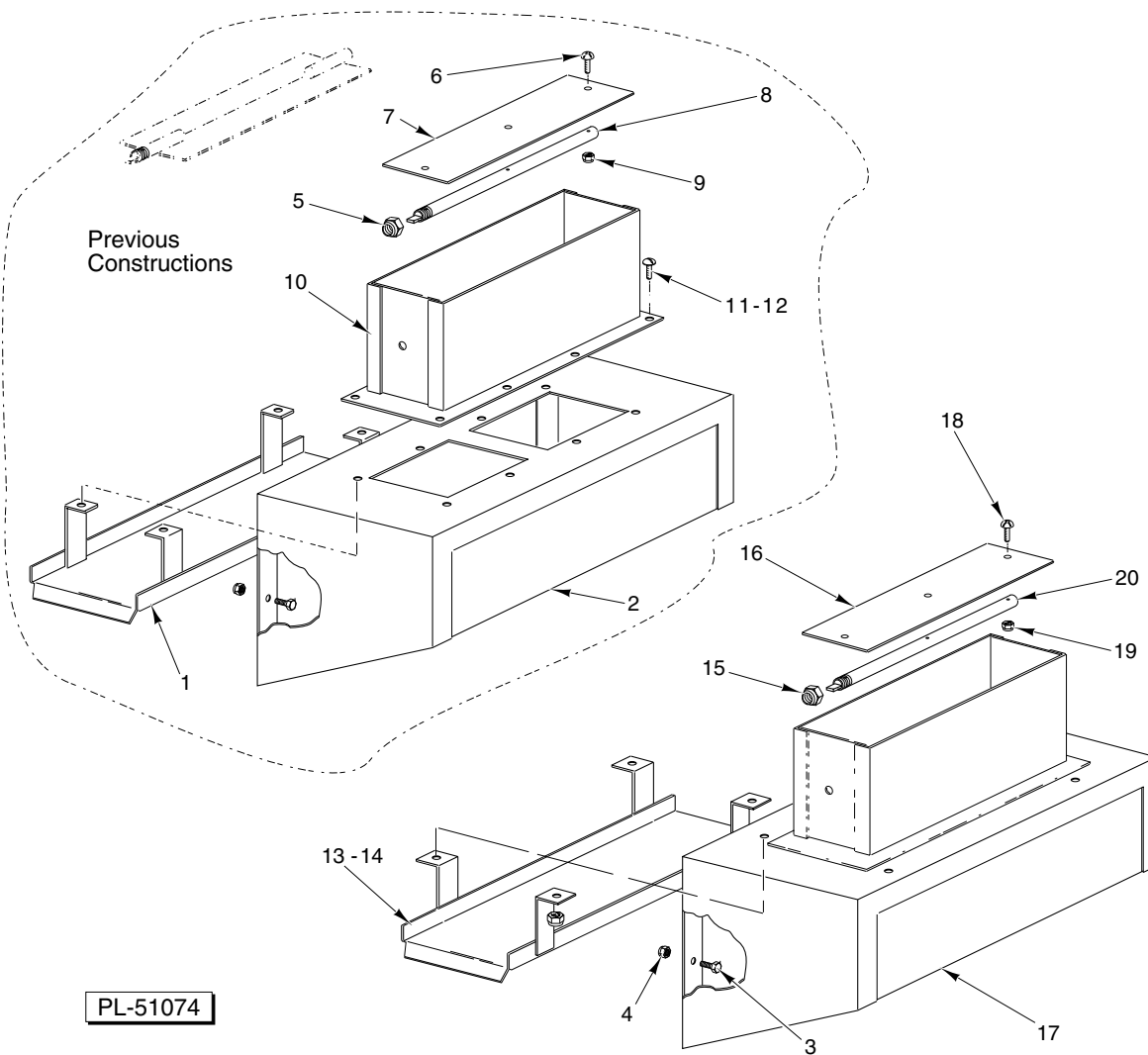

VENT HOOD

vsezip.ru

+7(812)987-08-81

VENT HOOD

ILLUS.	PART NO.	NAME OF PART	AMT.
PL-51074			
1	00-080553	Drip Shield Assy.	1
2	00-079467-00002	Vent Hood Assy.	1
3	SC-041-05	Cap Screw 1/4-20 x 5/8 Hex Hd. (SST)	11
4	NS-031-19	Stop Nut 1/4-20 Elastic (SST)	11
5	NS-036-12	Stop Nut 3/8-24 Elastic	1
6	SC-125-25	Mach. Screw 6-32 x 3/4 Rd. Hd. (SST)	3
7	00-075623	Damper – Vent Stack	1
8	00-064919	Shaft – Damper	1
9	NS-031-50	Stop Nut 6-32 Hex (SST)	3
10	00-075621	Vent Stack Assy.	1
11	SC-053-02	Mach. Screw 10-24 x 1/2 Truss Hd. (SST)	8
12	NS-031-15	Stop Nut 10-24 Hex (SST)	8
13	00-435799	Drip Shield Assy.	1
14	NS-031-15	Stop Nut 10-24 Hex (SST)	4
15	NS-036-12	Stop Nut 3/8-24 Elastic	1
16	00-075623	Damper – Vent Stack	1
17	00-435794-00001	Vent Hood Assy. (Incls. Items 13 thru 16, 18, 19, & 20)	1
18	SC-125-25	Mach. Screw 6-32 x 3/4 Rd. Hd. (SST)	3
19	NS-031-50	Stop Nut 6-32 Hex (SST)	3
20	00-064919	Shaft – Damper	1

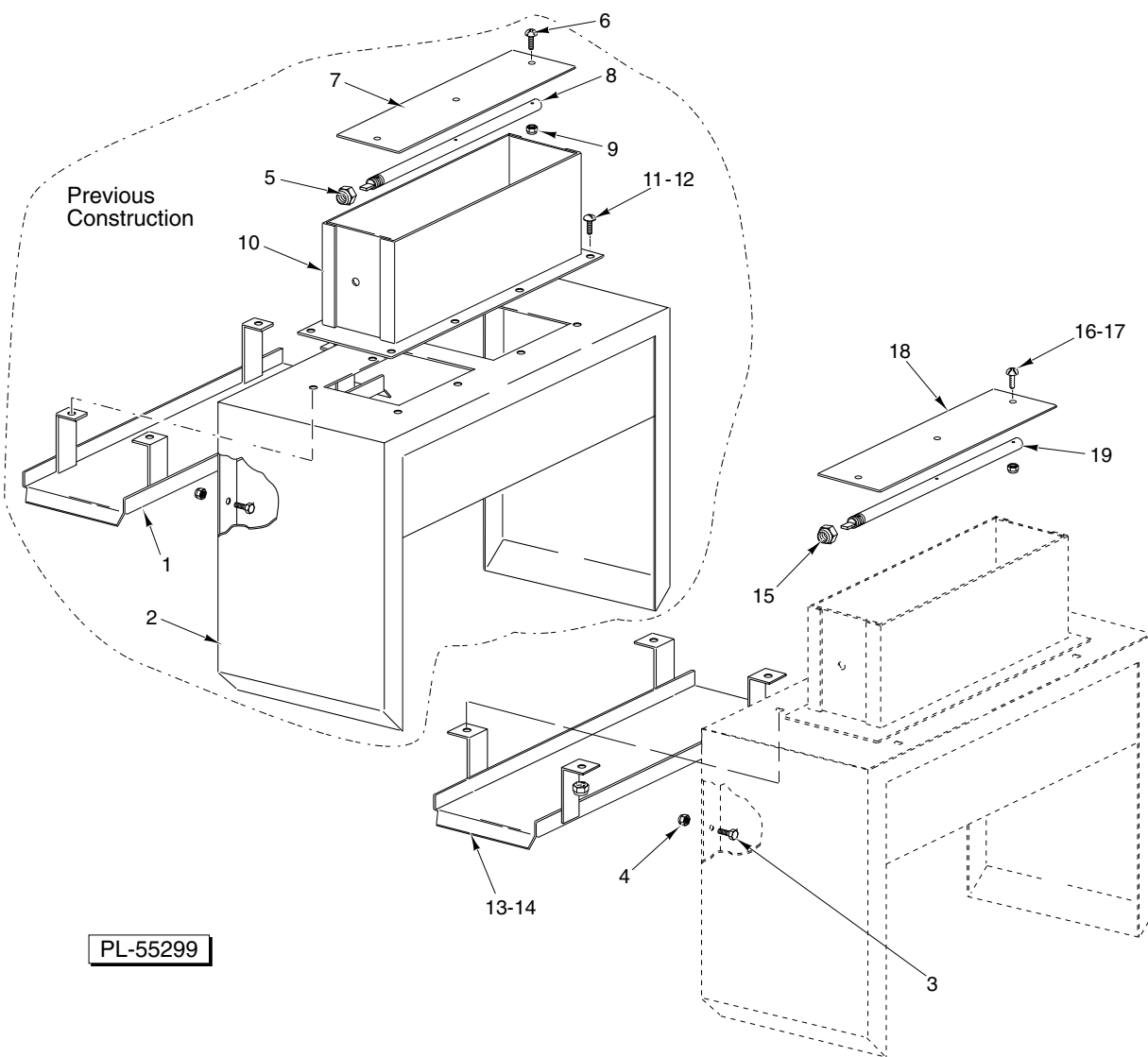

EXTENDED HOOD

vsezip.ru

+7(812)987-08-81

EXTENDED HOOD

ILLUS.	PART NO.	NAME OF PART	AMT.
	PL-55299		
1	00-080553	Drip Shield Assy.	1
2	00-079463-00002	Extended Hood Assy.	1
3	SC-041-05	Cap Screw 1/4-20 x 5/8 Hex Hd. (SST)	13
4	NS-031-19	Stop Nut 1/4-20 Elastic (SST)	13
5	NS-036-12	Stop Nut 3/8-24 Elastic	1
6	SC-125-25	Mach. Screw 6-32 x 3/4 Rd. Hd. (SST)	3
7	00-075623	Damper – Vent Stack	1
8	00-064919	Shaft – Damper	1
9	NS-031-50	Stop Nut 6-32 Hex (SST)	3
10	00-075621	Vent Stack Assy.	1
11	SC-053-02	Mach. Screw 10-24 x 1/2 Truss Hd. (SST)	8
12	NS-031-15	Stop Nut 10-24 Hex (SST)	8
13	00-435799	Drip Shield Assy.	1
14	NS-031-15	Stop Nut 10-24 Hex (SST)	4
15	NS-036-12	Stop Nut 3/8-24 Elastic	1
16	SC-125-25	Mach. Screw 6-32 x 3/4 Rd. Hd. (SST)	3
17	NS-031-50	Stop Nut 6-32 Hex (SST)	3
18	00-075623	Damper – Vent Stack	1
19	00-064919	Shaft – Damper	1

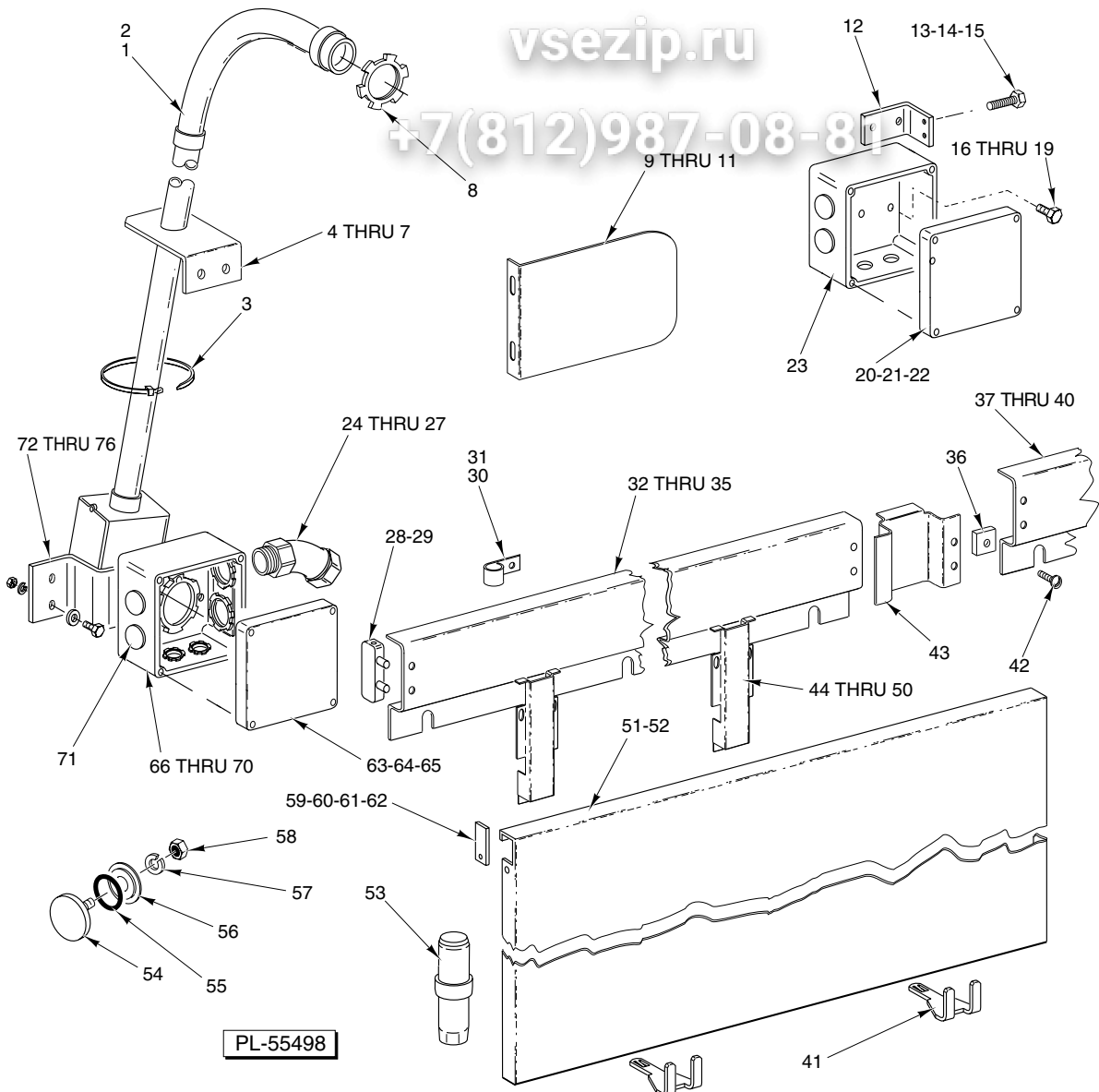

**MISCELLANEOUS
(WASH SECTION)**

ILLUS.	PART NO.	NAME OF PART	AMT.
PL-55498			
1	00-274232	Conduit – PVC (26 ¹ / ₈ Door Height) (Incls. Item 4)	1
2	00-274709	Conduit – PVC (32 ¹ / ₈ Door Height) (Incls. Item 4)	AR
3	00-122577-00002	Wire Tie	2
4	00-271044	Bracket	2
5	SC-041-50	Cap Screw 1/4-20 x 1/2 Hex Hd.	1
6	WL-006-17	Lockwasher 1/4 Medium	2
7	NS-015-01	Nut 1/4-20 Hex (SST)	2
8	FE-009-07	Lock Nut 1 1/4	2
9	00-287625	Splash Shield (26 ¹ / ₈ Door Height)	2
10	NS-031-15	Stop Nut 10-24 Hex (SST)	4

MISCELLANEOUS (Cont.)
(WASH SECTION)

ILLUS. PL-55498	PART NO.	NAME OF PART	AMT.
11	SC-053-02	Mach. Screw 10-24 x 1/2 Phil. Truss Hd. (SST)	4
12	00-270925	Bracket (RH)	1
13	SC-041-12	Cap Screw 5/16-18 x 7/8 Hex Hd.	2
14	WL-006-23	Lockwasher 5/16 Medium (SST)	2
15	NS-015-11	Nut 5/16-18 Hex	2
16	SC-041-05	Cap Screw 1/4-20 x 5/8 Hex Hd. (SST)	2
17	WS-003-49	Washer	2
18	WL-006-17	Lockwasher 1/4 Medium	2
19	NS-015-01	Nut 1/4-20 Hex (SST)	2
20	00-288465	Lid & Gasket Assy. (Incls. Item 21)	1
21	00-112007	Gasket	1
22	SD-012-20	Self-Tapping Screw 8-32 x 1/2 Phil. Truss Hd., Type T	4
23	00-270923-00002	Box – Junction (RH)	1
24	FE-008-44	Connector 45 Deg. (3/4 Male Thd. x 3/4 Thinwall)	2
25	FE-008-11	Gasket – Electrical	2
26	FE-006-06	Lock Nut 3/4	2
27	FE-007-32	Connector – Conduit 3/4 TS	2
28	00-271057	Cap – Wireway	2
29	SD-007-38	Self-Tapping Screw 8 x 1/4 Phil. Bind Hd., Type B	2
30	00-294677-00003	Clamp – Wire (3/4 I.D.)	AR
31	NS-047-94	Lock Nut Special 3/16	AR
32	00-271056	Wireway – Horizontal	1
33	WS-017-06	Washer	3
34	WL-006-17	Lockwasher 1/4 Medium	3
35	NS-015-01	Nut 1/4-20 Hex (SST)	3
36	00-072937	Speed Nut 4-40	2
37	00-328804	Wireway – Horizontal (C54A Series)	1
38	WS-017-06	Washer	2
39	WL-006-17	Lockwasher 1/4 Medium	2
40	NS-015-01	Nut 1/4-20 Hex (SST)	2
41	00-271061	Support	2
42	SC-127-55	Mach. Screw 4-40 x 3/8 Rd. Hd. (SST)	2
43	00-274252	Wire Raceway (C54A Series)	2
44	00-271055	Wireway – Vertical	2
45	SC-114-15	Mach. Screw 10-24 x 3/8 Rd. Hd. (SST)	2
46	WL-006-07	Lockwasher #10 Medium	2
47	WS-019-06	Washer	4
48	WL-006-17	Lockwasher 1/4 Medium	4
49	NS-015-01	Nut 1/4-20 Hex (SST)	4
50	WS-019-19	Washer	2
51	00-436798	Panel – Front Trim (C44A/AW)	1
52	00-328809	Panel – Front Trim (C54A)	1
53	00-288946-00002	Foot – Adjustable (1 1/2 to 2 3/4)	4
54	00-119244	Cap & Stud Assy.	1
55	00-067500-00031	O-Ring	1
56	00-119254	Retainer – Cap & Stud	1
57	WL-006-17	Lockwasher 1/4 Medium	1
58	NS-015-01	Nut 1/4-20 Hex (SST)	1
59	00-436888	Cover – Panel Notch	2
60	SC-066-05	Mach. Screw 10-24 x 3/8 Phil. Truss Hd.	2
61	WS-019-06	Washer	2
62	NS-031-16	Stop Nut 10-24 Hex (SST)	2
63	00-288465	Lid & Gasket Assy. (Incls. Item 64)	1
64	00-112007	Gasket	1
65	SD-012-20	Self-Tapping Screw 8-32 x 1/2 Phil. Truss Hd., Type T	4
66	00-270923-00001	Box – Junction (LH)	1
67	SC-041-05	Cap Screw 1/4-20 x 5/8 Hex Hd. (SST)	2
68	WS-003-49	Washer	2
69	WL-006-17	Lockwasher 1/4 Medium	2
70	NS-015-01	Nut 1/4-20 Hex (SST)	2
71	PB-004-08	Plug Button 7/8 (Heyco 2703)	AR
72	00-270922	Bracket (LH)	1
73	SC-041-12	Cap Screw 5/16-18 x 7/8 Hex Hd.	2
74	WS-017-08	Washer	2
75	WL-006-23	Lockwasher 5/16 Medium (SST)	2
76	NS-015-11	Nut 5/16-18 Hex	2

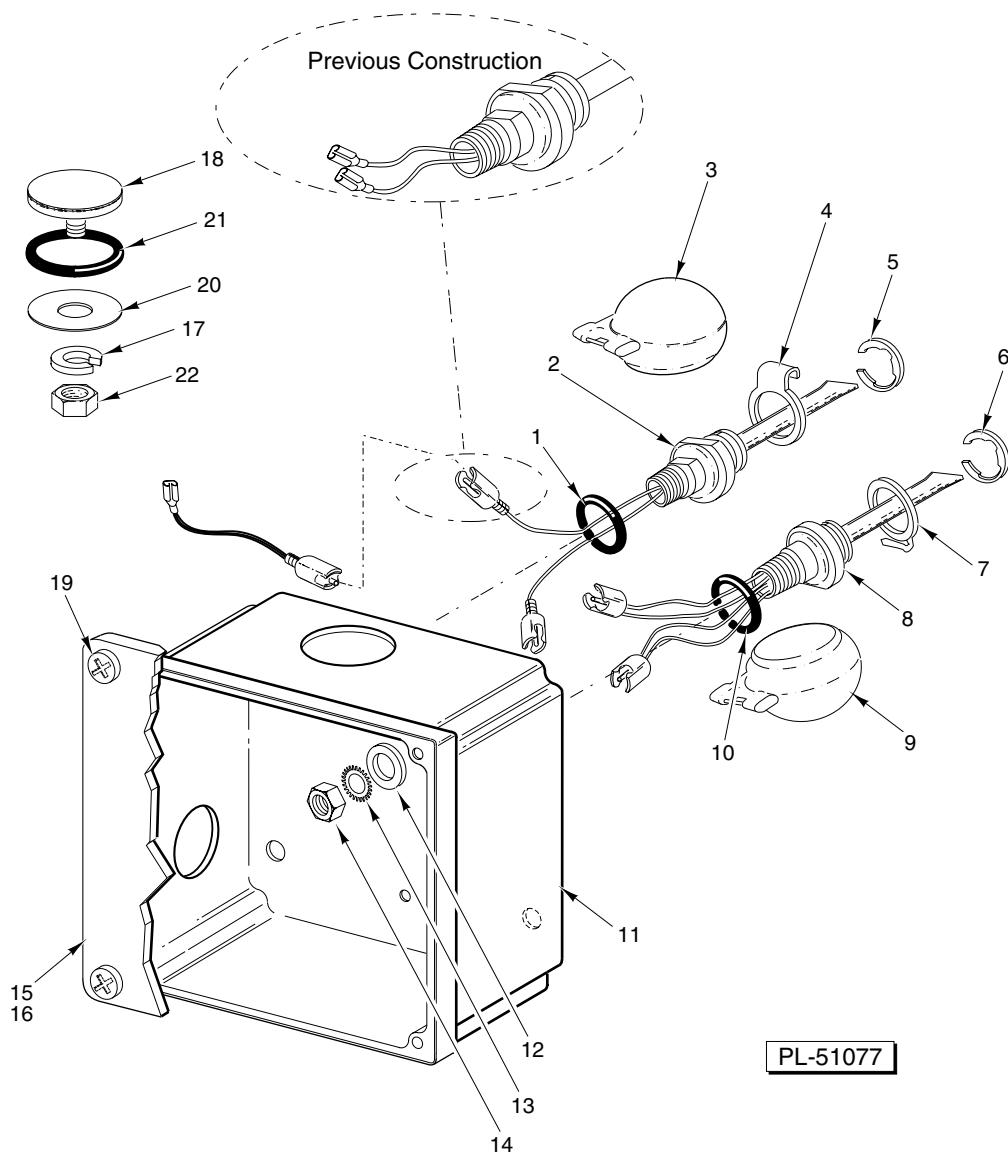

**LOW WATER PROTECTION
(STEAM HEAT/WASH TANK)**

vsezip.ru

+7(812)987-08-81

**LOW WATER PROTECTION
(STEAM HEAT/WASH TANK)**

ILLUS.	PART NO.	NAME OF PART	AMT.
PL-51077			
1	00-067500-00072	O-Ring	AR
*2	00-328495	Probe & Switch Assy. (2 Wire) (Water Level) (Incls. Items 3, 4, & 5)	AR
3	00-122674	Float Assy.	AR
4	00-112467	Retainer – Float	AR
5	RR-010-13	Retaining Ring	AR
6	RR-010-13	Retaining Ring	1
7	00-112467	Retainer – Float	1
8	00-186091	Probe & Switch Assy. (4 Wire) (Temperature & Water Level) (Incls. Items 6, 7, & 9)	1
9	00-122674	Float Assy.	1
10	00-067500-00072	O-Ring	1
11	00-271112-00001	Box – Steam Heat	1
12	WS-010-40	Washer – Thrust	AR
13	WL-014-31	Lockwasher 1/2 External Shakeproof (SST)	AR
14	NS-018-28	Jam Nut 1/2-20 Hex	AR
15	00-288465	Lid & Gasket Assy. (Incls. Item 16)	1
16	00-112007	Gasket	1
*17	WL-006-17	Lockwasher 1/4 Medium	AR
*18	00-119244-00002	Cap	AR
19	SD-012-20	Self-Tapping Screw 8-32 x 1/2 Phil. Truss Hd., Type T	4
*20	WS-003-47	Washer	AR
*21	00-067500-00031	O-Ring	AR
*22	NS-015-01	Nut 1/4-20 Hex (SST)	AR
	00-294357-00001	Housing – Connector (Nat)	AR
	00-294357-00002	Housing – Connector (Black)	AR
	00-065890-00029	Connector – Insulated	AR

* Used on CRS76A and CRS66A/AW in place of Items 1 thru 5 in wash tank.

** Must order two jumper wires, Part #328758.

vsezip.ru

Previous Construction

+7(812)987-08-81

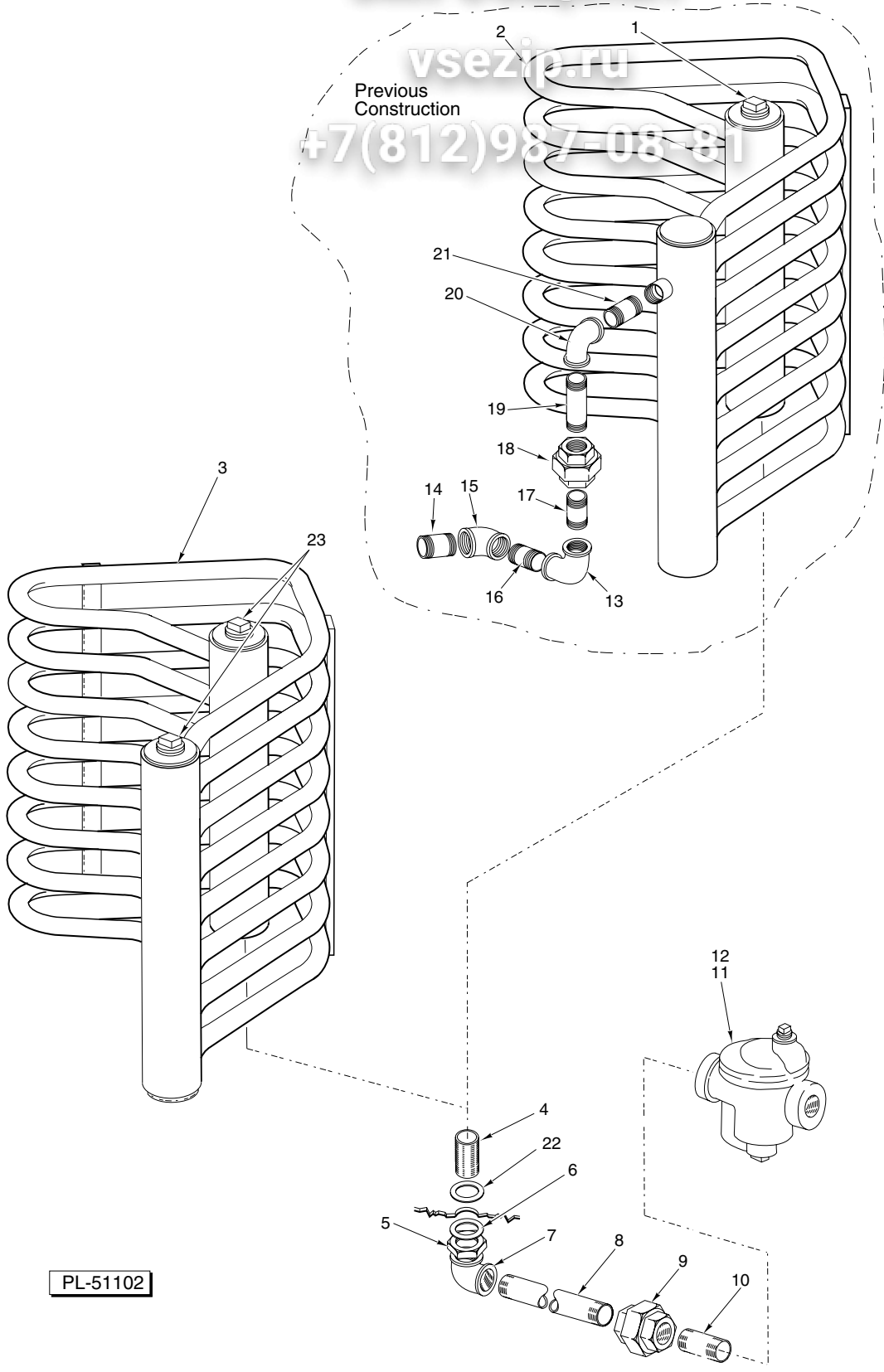

PL-51102

STEAM COIL HEAT

vsezip.ru

+7(812)987-08-81

STEAM COIL HEAT

ILLUS.	PART NO.	NAME OF PART	AMT.
PL-51102			
1	FP-052-09	Pipe Plug $\frac{3}{4}$ Sq. Hd. (SST)	1
2	00-274547	Coil – Steam (Side Inlet)	1
3	00-329243	Coil – Steam	1
4	FP-080-17	Nipple $\frac{3}{4}$ x 2 (TBE; 1 $\frac{1}{2}$ RTOE) (SST)	1
5	FP-053-09	Lock Nut $\frac{3}{4}$ NPSL (SST)	1
6	WS-013-45	Washer	1
7	FP-013-22	Elbow $\frac{3}{4}$ x 90 Deg.	1
8	FP-036-12	Nipple $\frac{3}{4}$ x 7 $\frac{3}{4}$ TBE	1
9	FP-022-17	Union $\frac{3}{4}$ (Grd. Seat)	1
10	FP-036-92	Nipple $\frac{3}{4}$ x 1 $\frac{3}{8}$ TBE	1
11	00-118316	Steam Trap (0-20 PSI)	1
12	00-118317	Steam Trap (21-50 PSI)	1
13	FP-049-15	Elbow $\frac{3}{4}$ x 90 Deg. (SST)	1
14	FP-054-27	Nipple $\frac{3}{4}$ x 1 $\frac{3}{8}$ TBE (SST)	1
15	FP-077-29	Elbow $\frac{3}{4}$ x 45 Deg. (SST)	1
16	FP-054-28	Nipple $\frac{3}{4}$ x 1 $\frac{1}{2}$ TBE (SST)	1
17	FP-054-27	Nipple $\frac{3}{4}$ x 1 $\frac{3}{8}$ TBE (SST)	1
18	FP-050-14	Union $\frac{3}{4}$ (Grd. Seat) (SST)	1
19	FP-054-44	Nipple $\frac{3}{4}$ x 2 $\frac{1}{2}$ TBE (SST)	1
20	FP-049-15	Elbow $\frac{3}{4}$ x 90 Deg. (SST)	1
21	FP-054-28	Nipple $\frac{3}{4}$ x 1 $\frac{1}{2}$ TBE (SST)	1
22	WS-013-45	Washer	1
23	FP-052-09	Pipe Plug $\frac{3}{4}$ Sq. Hd. (SST)	2

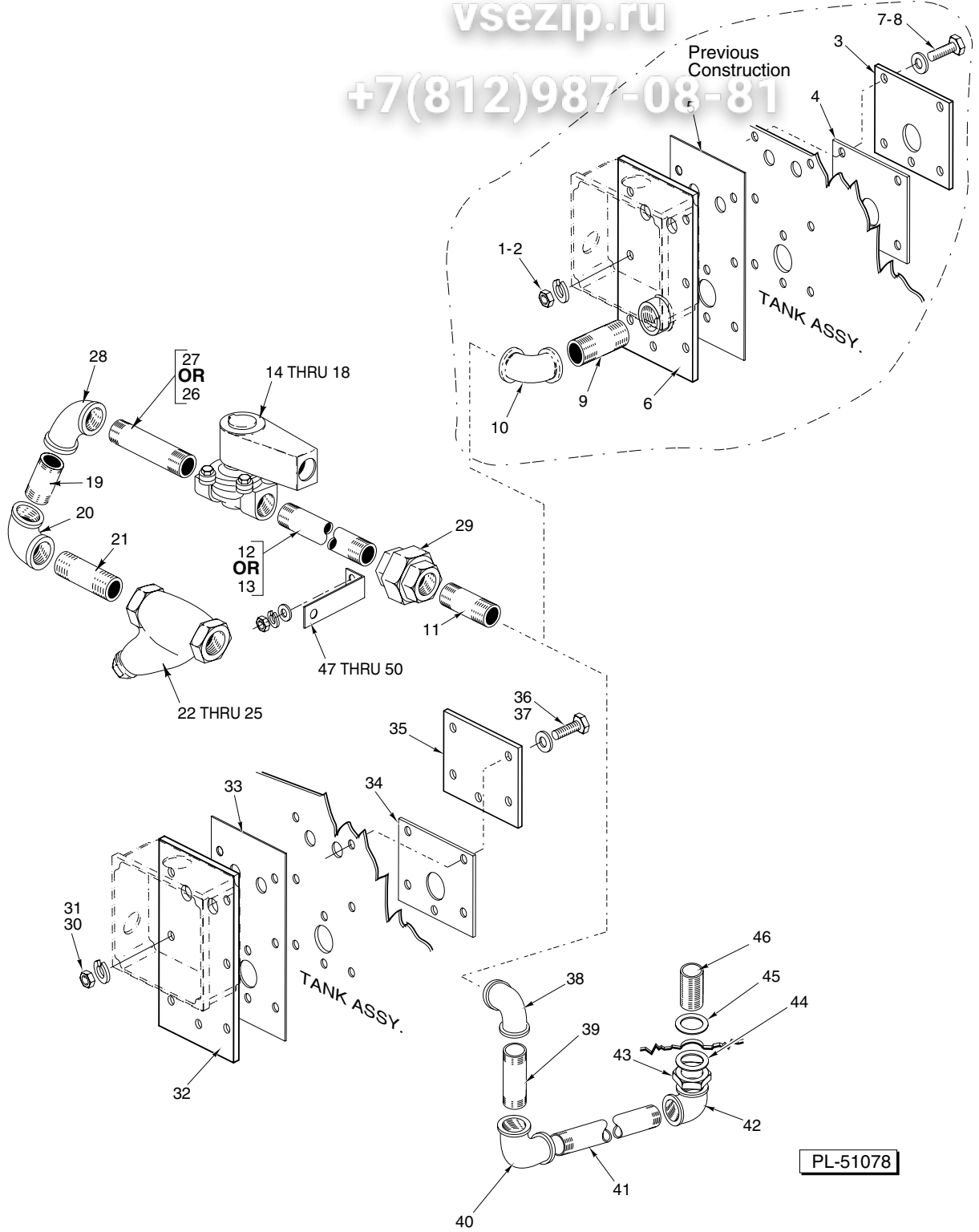

PIPING – STEAM COILS

vsezip.ru

PIPING - STEAM COILS
+7(812)987-08-81

ILLUS.	PART NO.	NAME OF PART	AMT.
PL-51078			
1	NS-015-11	Nut ⁵ / ₁₆ -18 Hex	7
2	WL-006-23	Lockwasher ⁵ / ₁₆ Medium (SST)	7
3	00-435027	Plate	1
4	00-435026	Gasket	1
5	00-271109	Gasket – Mounting	1
6	00-271108	Plate – Mounting	1
7	WS-017-08	Washer	14
8	SC-041-15	Cap Screw ⁵ / ₁₆ -18 x 1 ¹ / ₄ Hex Hd.	7
9	FP-036-92	Nipple ³ / ₄ x 1 ³ / ₈ TBE	1
10	FP-013-22	Elbow ³ / ₄ x 90 Deg.	1
11	FP-036-92	Nipple ³ / ₄ x 1 ³ / ₈ TBE	1
12	FP-036-13	Nipple ³ / ₄ x 7 ³ / ₈ TBE	1
13	FP-036-12	Nipple ³ / ₄ x 7 ³ / ₄ TBE (Used on Side Inlet Construction)	1
14	00-270329-00001	Solenoid Valve (120 V.) (Incls. Items 16 & 18)	1
*15	00-270329-00002	Solenoid Valve (240 V.) (Incls. Items 17 & 18)	1
16	00-270318-00001	Coil – Solenoid Valve (120 V.)	1
*17	00-270318-00002	Coil – Solenoid Valve (240 V.)	1
18	00-270336	Service Kit – Solenoid Valve	1
19	FP-036-92	Nipple ³ / ₄ x 1 ³ / ₈ TBE	1
20	FP-013-22	Elbow ³ / ₄ x 90 Deg.	1
21	FP-036-92	Nipple ³ / ₄ x 1 ³ / ₈ TBE	1
22	00-186922	Line Strainer ³ / ₄ (Brass) (Incls. Items 23 thru 25)	1
23	00-186923	Plug – Branch	1
24	00-186924	Gasket – Branch Plug	1
25	00-186925	Screen – Line Strainer	1
26	FP-059-76	Nipple ³ / ₄ x 2 ¹ / ₄ TBE (Used on Side Inlet Construction)	1
27	FP-059-22	Nipple ³ / ₄ x 1 ³ / ₄ TBE	1
28	FP-013-22	Elbow ³ / ₄ x 90 Deg.	1
29	FP-022-17	Union ³ / ₄ (Ground Seat)	1
30	NS-015-11	Nut ⁵ / ₁₆ -18 Hex	7
31	WL-006-23	Lockwasher ⁵ / ₁₆ Medium (SST)	7
32	00-328776	Plate – Outer	1
33	00-271109	Gasket – Mounting	1
34	00-435026	Gasket	1
35	00-328777	Plate – Inner	1
36	SC-041-15	Cap Screw ⁵ / ₁₆ -18 x 1 ¹ / ₄ Hex Hd.	7
37	WS-017-08	Washer	14
38	FP-013-22	Elbow ³ / ₄ x 90 Deg.	1
39	FP-036-05	Nipple ³ / ₄ x 3 TBE	1
40	FP-013-22	Elbow ³ / ₄ x 90 Deg.	1
41	FP-087-48	Nipple ³ / ₄ x 8 TBE	1
42	FP-013-22	Elbow ³ / ₄ x 90 Deg.	1
43	FP-053-09	Lock Nut ³ / ₄ NPSL (SST)	1
44	WS-013-45	Washer	1
45	WS-013-45	Washer	1
46	FP-080-17	Nipple ³ / ₄ x 2 (TBE; 1 ¹ / ₂ RTOE) (SST)	1
47	00-289721	Bracket – Air Baffle	1
48	WS-003-49	Washer	1
49	WL-006-17	Lockwasher ¹ / ₄ Medium	1
50	NS-015-01	Nut ¹ / ₄ -20 Hex (SST)	1

* Used on machines W/O 120 V. pilot circuit.

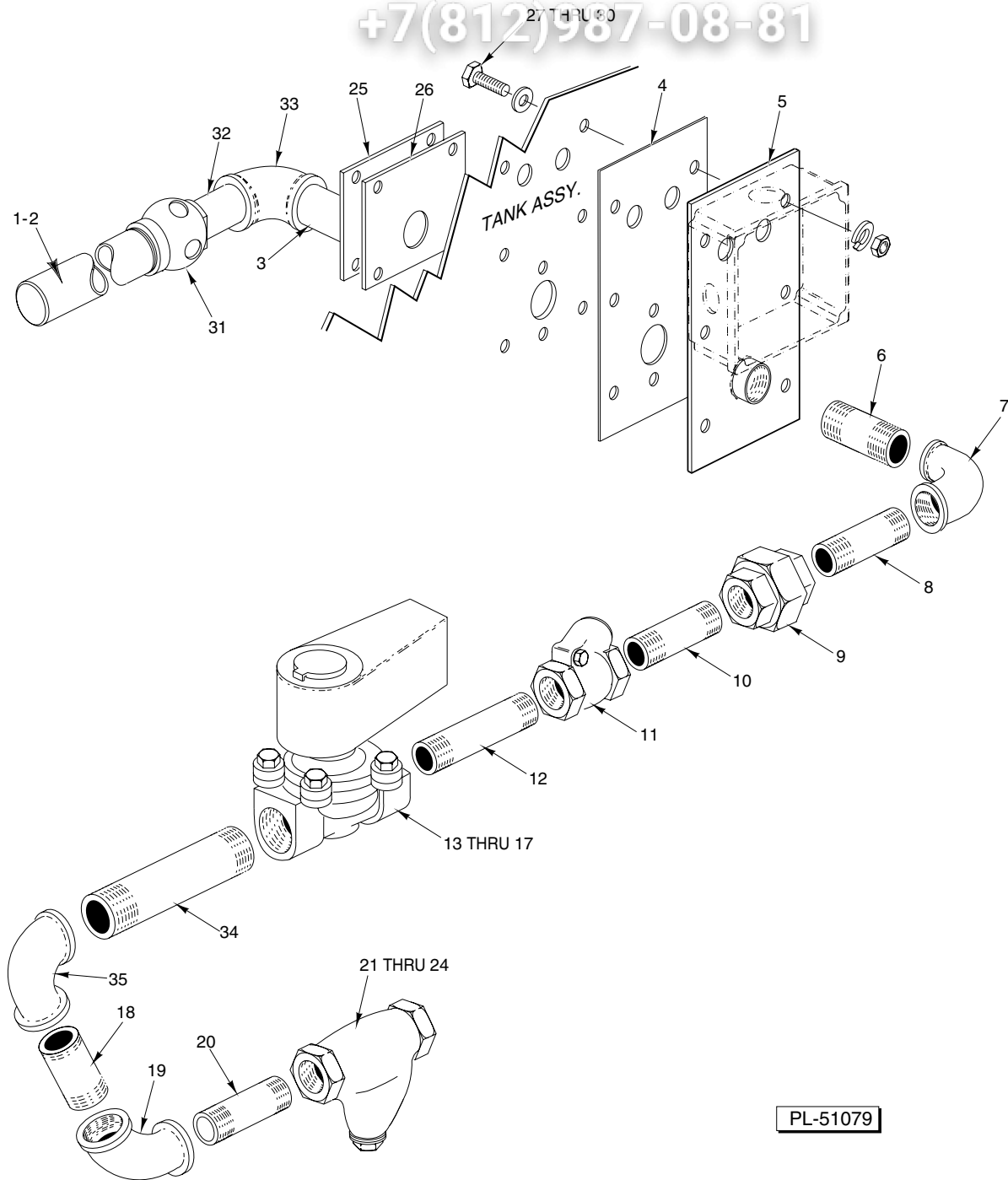

STEAM INJECTOR HEAT

vsezip.ru

+7(812)987-08-81

STEAM INJECTOR HEAT

ILLUS.	PART NO.	NAME OF PART	AMT.
	PL-51079		
1	00-271110	Piping – Steam Injector (Incls. Items 2, 31, & 32)	1
2	FP-085-05	Nipple 1 x 10 ¹ / ₂ S.T.O.E. (SST)	1
3	FP-054-32	Nipple ³ / ₄ x 4 ³ / ₈ Lg. TBE (SST)	1
4	00-271109	Gasket – Mounting	1
5	00-271108	Plate – Mounting	1
6	FP-036-92	Nipple ³ / ₄ x 1 ³ / ₈ TBE	1
7	FP-013-22	Elbow ³ / ₄ x 90 Deg.	1
8	FP-036-92	Nipple ³ / ₄ x 1 ³ / ₈ TBE	1
9	FP-022-17	Union ³ / ₄ (Ground Seat)	1
10	FP-036-92	Nipple ³ / ₄ x 1 ³ / ₈ TBE	1
11	00-074696	Check Valve ³ / ₄	1
12	FP-059-14	Nipple ³ / ₄ x 4 ¹ / ₂ TBE	1
13	00-270329-00001	Solenoid Valve ³ / ₄ (120 V.) (Incls. Items 15 & 17)	1
*14	00-270329-00002	Solenoid Valve ³ / ₄ (240 V.) (Incls. Items 16 & 17)	1
15	00-270318-00001	Coil – Solenoid Valve (120 V.)	1
*16	00-270318-00002	Coil – Solenoid Valve (240 V.)	1
17	00-270336	Service Kit – Solenoid Valve	1
18	FP-036-92	Nipple ³ / ₄ x 1 ³ / ₈ TBE	1
19	FP-013-22	Elbow ³ / ₄ x 90 Deg.	1
20	FP-036-92	Nipple ³ / ₄ x 1 ³ / ₈ TBE	1
21	00-186922	Line Strainer ³ / ₄ (Incls. Items 22, 23, & 24)	1
22	00-186923	Plug – Branch	1
23	00-186924	Gasket – Branch Plug	1
24	00-186925	Screen – Line Strainer	1
25	00-435027	Plate	1
26	00-435026	Gasket	1
27	SC-041-15	Cap Screw ⁵ / ₁₆ -18 x 1 ¹ / ₄ Hex Hd.	7
28	WS-017-08	Washer	14
29	WL-006-23	Lockwasher ⁵ / ₁₆ Medium (SST)	7
30	NS-015-11	Nut ⁵ / ₁₆ -18 Hex	7
31	00-288671	Heater – Water	1
32	FP-054-44	Nipple ³ / ₄ x 2 1/2 TBE (SST)	1
33	FP-049-15	Elbow ³ / ₄ x 90 Deg. (SST)	1
34	FP-059-76	Nipple ³ / ₄ x 2 1/4 TBE	1
35	FP-013-22	Elbow ³ / ₄ x 90 Deg.	1
	00-538850-00002	Sealer – Pipe	AR
	00-545595	Sealer (¹ / ₈ Rd.)	AR

* Used on machines W/O 120 V. pilot circuit.

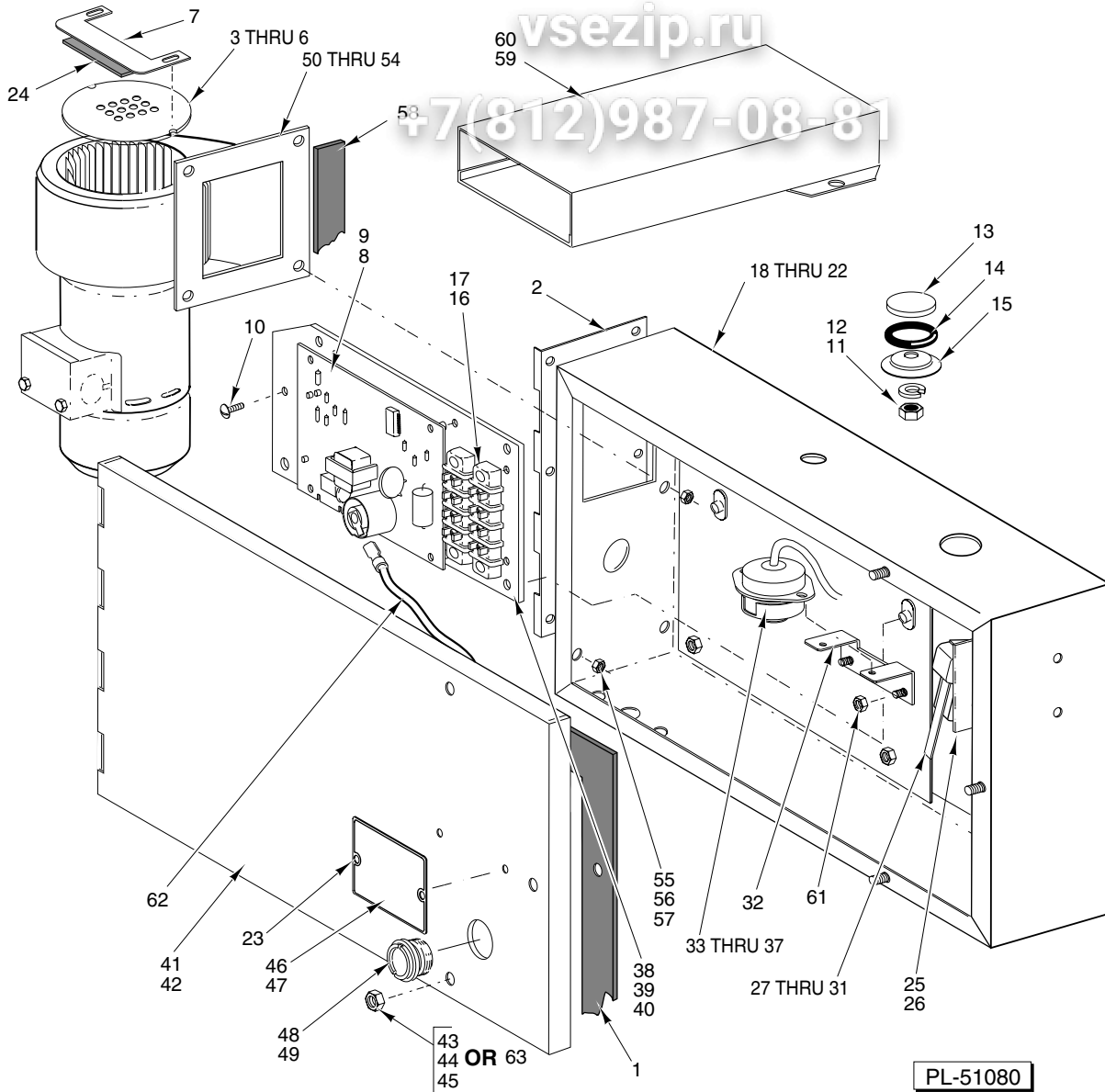

CONTROL BOX – GAS HEAT

ILLUS.	PART NO.	NAME OF PART	AMT.
PL-51080			
1	00-436745	Gasket-Lid	1
2	00-436102	Bracket – Lid Mounting (Use W/Item 42)	1
3	00-274569	Plate – Restrictor (12 Holes) (Marked NG 60 Hz.) (Shown)	AR
4	00-436065	Plate – Restrictor (16 Holes) (Marked NG & LP 60 Hz. or 60 Hz.) (Nat. or LP Gas)	AR
5	00-436763	Plate – Restrictor (24 Holes) (Marked NG 50 Hz.)	AR
6	00-436765	Plate – Restrictor (28 Holes) (Marked LP 50 Hz.)	AR
7	00-435539	Plate-Adjusting	1
8	00-436853	Ignitor Board 24 VAC	1
9	SD-009-40	Self-Tapping Screw 6-32 x 3/4 Phil. Pan Hd., Type F	4
10	SD-009-05	Self-Tapping Screw 6-32 x 5/16 Phil. Rd.Hd., Type F	1
11	NS-015-01	Nut 1/4-20 Hex (SST)	1
12	WL-006-17	Lockwasher 1/4 Medium	1
13	00-119244	Cap & Stud Assy.	1

CONTROL BOX & GAS HEAT (Cont.)

ILLUS.	PART NO.	NAME OF PART	AMT.
PL-51080			
14	00-067500-00031	O-Ring	1
15	00-119254	Retainer – Cap & Stud	1
16	00-294325-014-1	Block Terminal	2
17	SD-009-17	Self-Tapping Screw 8-32 x 5/8 Phil. Pan Hd., Type F	4
18	00-436757	Gas Heat Box (Shown) (Use W/Item 42)	1
19	00-435022	Gas Heat Box (Use W/Item 41)	1
20	NS-015-01	Nut 1/4-20 Hex (SST)	7
21	WL-006-17	Lockwasher 1/4 Medium	7
22	WS-017-06	Washer	7
23	00-114247-00001	Drive Rivet	2
24	00-526454	Foam Tape (1 Wide x 1/8 Thk.)	AR
25	00-274514-00001	Bracket	1
26	SC-067-07	Mach. Screw 10-24 x 1/2 Hex Hd. (SST)	2
27	00-087711-00221	Switch – Door S.P.D.T.	1
28	00-270280	Insulator – Door Switch	1
29	SC-112-90	Mach. Screw 4-40 x 1 Pan Hd.	2
30	WL-003-03	Lockwasher #4 Medium	2
31	NS-009-02	Mach. Nut 4-40 Hex	2
32	00-271122	Bracket – Thermostat	1
33	00-271123	Protector – High Limit	1
34	00-328758	Jumper Wire – Socket Type Connector (Use W/Item 33)	2
35	00-293946	Sleeve – Lead	1
36	SC-021-08	Mach. Screw 6-32 x 3/8 Rd. Hd. (SST)	2
37	NS-031-50	Stop Nut 6-32 Hex (SST)	2
38	00-435046	Control Plate	1
39	SC-018-01	Mach. Screw 10-24 x 3/8 Pan Hd.	3
40	WL-014-07	Lockwasher #10 External Shakeproof (SST)	3
41	00-435023-00001	Lid – Gas Heat Box (W/O Notches)	1
42	00-436101-00001	Lid – Gas Heat Box (Shown) (W/Notches)	1
43	WS-029-79	Washer	AR
44	WL-006-07	Lockwasher #10 Medium	AR
45	SC-067-07	Machine Screw 10-24 x 1/2 Hex Hd. (SST)	AR
46	00-435375	Data Plate (L.P. Gas)	1
47	00-435374	Data Plate (Natural Gas)	1
48	00-435024	Eye – Box	1
49	NS-035-25	Lock Nut 3/4-16 Palnut	1
*50	00-274524	Blower Motor (240 V.)	1
51	00-274524-00002	Blower Motor (120 V.)	1
52	SC-113-26	Mach. Screw 1/4-20 x 5/8 Hex Hd.	4
53	NS-031-21	Stop Nut – Special 1/4-20 Hex	4
54	WS-003-48	Washer – M6 Flat	4
55	SC-113-26	Mach. Screw 1/4-20 x 5/8 Hex Hd.	2
56	WS-003-48	Washer – M6 Flat	2
57	NS-031-21	Stop Nut – Special 1/4-20 Hex	2
58	00-529390	Foam Tape (3/4 Wide x 1/16 Thk.)	AR
59	00-328650	Air Inlet Channel (Nat. Gas)	1
60	SD-012-20	Self-Tapping Screw 8-32 x 1/2 Phil. Truss Hd., Type T	2
61	NS-031-15	Stop Nut 10-24 Hex (SST)	2
62	00-271146	Cable – High Voltage	1
63	NS-031-15	Stop Nut 10-24 Hex (SST)	3
	00-294357-00001	Housing – Connector (Nat)	AR
	00-294357-00002	Housing – Connector (Black)	AR
	00-294677-00003	Clamp – Wire (3/4 I.D.)	3
	NS-031-16	Stop Nut 10-24 Hex (SST)	3
	00-526408	Foam Tape	AR
	00-436766	Lid Assy. (Natural Gas) (Incls. Items 1, 23, 41, & 47)	1
	00-436767	Lid Assy. (Natural Gas) (Incls. Items 1, 23, 42, & 47)	1
	00-436768	Lid Assy. (L.P. Gas) (Incls. Items 1, 23, 42, & 46)	1

* Used on machines W/O 120 V. pilot circuit.

Запчасти

Previous Construction

+7(812)987-08-81

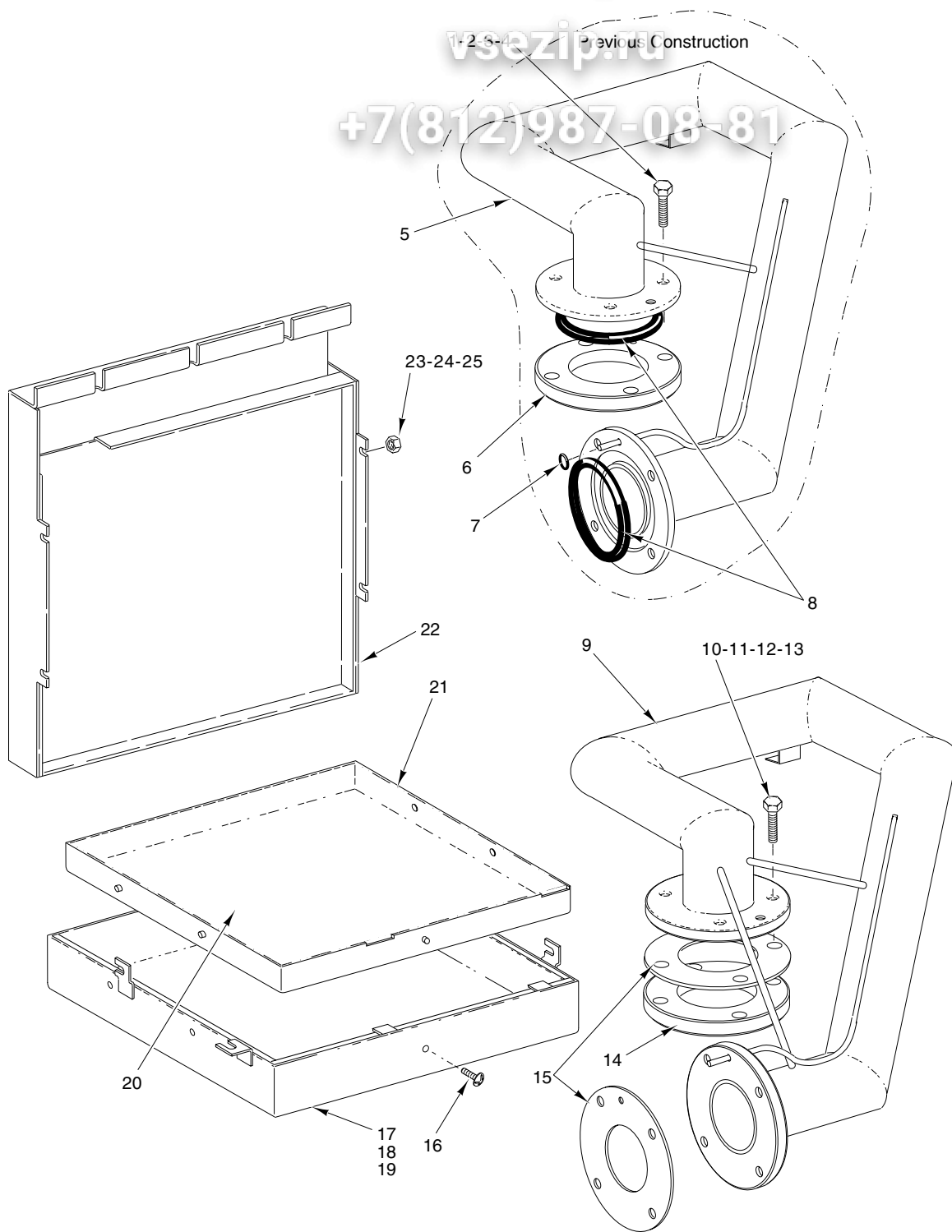

PL-55300

GAS BURNER AND FLUE

vsezip.ru

+7(812)987-08-81

GAS BURNER AND FLUE

ILLUS.	PART NO.	NAME OF PART	AMT.
PL-55300			
1	SC-041-14	Cap Screw ⁵ / ₁₆ -18 x 1 ¹ / ₈ Hex Hd. (SST)	AR
2	WS-017-08	Washer	AR
3	WL-006-22	Lockwasher ⁵ / ₁₆ Light	AR
4	NS-015-11	Nut ⁵ / ₁₆ -18 Hex	AR
5	00-274495	Tube – Immersion (W/O-Ring Sealing Flange)	1
6	00-435952	Flange – Immersion Tube	1
7	00-067500-00123	O-Ring	1
8	00-067500-00122	O-Ring	2
9	00-436087	Tube – Immersion (W/Gasket Sealing Flange)	1
10	SC-121-43	Cap Screw ⁷ / ₁₆ -14 x 1 ³ / ₄ Hex Hd.	AR
11	WS-021-07	Washer	AR
12	WL-019-77	Lockwasher ⁷ / ₁₆ Medium	AR
13	NS-047-97	Nut ⁷ / ₁₆ -14 Hex	AR
14	00-435952	Flange – Immersion Tube	1
15	00-436100	Gasket – Immersion Tube	2
16	SC-066-06	Mach. Screw 10-24 x ¹ / ₂ Phil. Truss Hd. (SST)	5
17	00-274496-00001	Shroud	1
18	00-274520	Insulation	1
19	00-274544	Shroud Assy. (Incls. Items 16, 17, 18, & 21)	1
20	00-274520	Insulation	1
21	00-274498-00001	Liner – Shroud	1
22	00-274565	Flue	1
23	NS-015-01	Nut ¹ / ₄ -20 Hex (SST)	11
24	WL-006-17	Lockwasher ¹ / ₄ Medium	11
25	WS-017-06	Washer	11

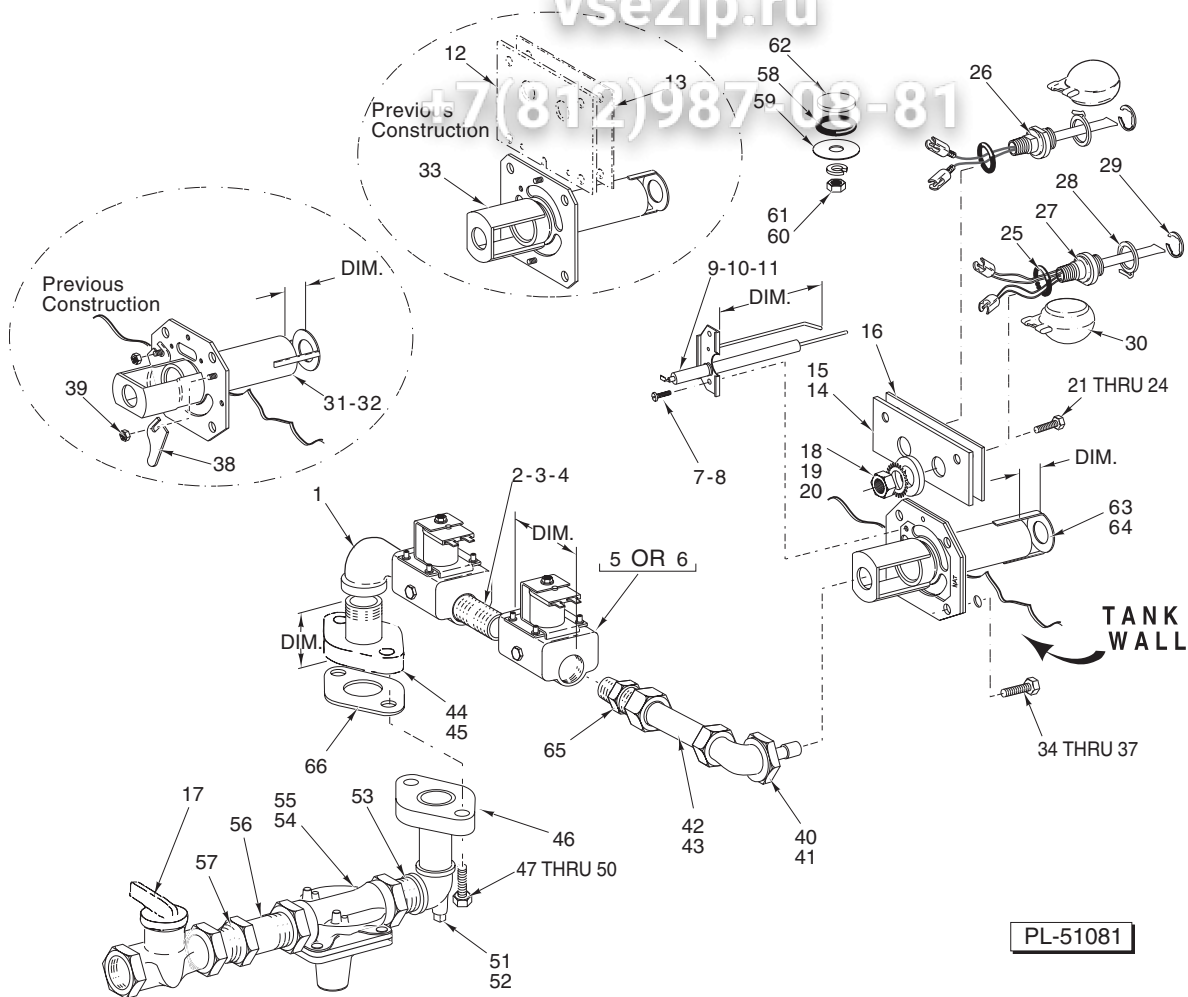

GAS HEAT COMPONENTS

ILLUS.	PART NO.	NAME OF PART	AMT.
PL-51081			
1	FP-015-10	Elbow – Street 3/8 x 90 Deg	1
2	FP-040-22	Nipple 3/8 x 2 TBE (Use W/two 2" Valves; Ref. Item 6)	AR
3	FP-040-18	Nipple 3/8 x 1 (Use W/two 2 1/2" Valves; Ref. Item 5)	AR
4	FP-076-07	Nipple 3/8 x 1 1/2 (Use W/one 2" Valve and one 2 1/2" Valve Combination)	AR
5	-	Gas Valve (Dim. 2 1/2) (Not Available) (Order Items 2, 3, or 4 & Item 6 as required)	AR
6	00-436118	Gas Valve (Dim. 2)	2
7	SC-093-03	Mach. Screw 8-32 x 3/8 Phil. Pan Hd. (SST)	2
8	WL-014-05	Lockwasher #8 External Shakeproof	2
9	00-435028	Electrode Ignition – Natural Gas (Dim. 3) (Marked 659)	AR
10	00-436792	Electrode Ignition – Natural Gas (Dim. 3 1/8) (Marked 665)	AR
11	00-436067	Electrode Ignition – L.P. Gas (Dim. 3 3/8) (Marked 662)	AR
12	-	Plate – Mounting (Not Available) (Order Items 14 & 16)	1
13	-	Gasket (Not Available) (Order Items 14 & 16)	1
14	00-435960-00002	Plate – Spacer (Shown)	AR
15	00-435960-00001	Plate – Spacer (W/O Mounting Holes)	AR
16	00-435961	Gasket (Service)	AR
17	00-291988-00003	Valve – Gas Cock	1
18	NS-018-28	Jam Nut 1/2-20 Hex	AR
19	WL-014-31	Lockwasher 1/2 External Shakeproof (SST)	AR

GAS HEAT COMPONENTS (Cont.)

ILLUS.	PART NO.	NAME OF PART	AMT.
PL-51081			
20	WS-010-40	Washer – Thrust	AR
21	SC-041-14	Cap Screw ⁵ / ₁₆ -18 x 1 ¹ / ₈ Hex Hd. (SST)	AR
22	WS-017-08	Washer	AR
23	WL-006-22	Lockwasher ⁵ / ₁₆ Light	AR
24	NS-015-11	Nut ⁵ / ₁₆ -18 Hex	AR
25	00-067500-00072	O-Ring	AR
26	00-328495	Probe & Switch Assy. (2 Wire) (Water Level) (Incls. Items 28, 29, & 30)	AR
27	00-186091	Probe & Swich Assy. (4 Wire) (Temperature & Water Level) (Incls. Items 28, 29, & 30)	1
28	00-112467	Retainer – Float	AR
29	RR-010-13	Retaining Ring	AR
30	00-122674	Float Assy.	AR
**31	-	Bracket – Orifice Natural Gas (Dim. ³ / ₄) (Marked NG)	AR
***32	00-436761	Bracket – Orifice L.P. Gas Only (Dim. ¹ / ₂) (Marked NAT/LP)	AR
33	00-435591	Bracket – Orifice	AR
34	SC-121-43	Cap Screw ⁷ / ₁₆ -14 x 1 ³ / ₄ Hex Hd.	4
35	WL-019-77	Lockwasher ⁷ / ₁₆ Medium	4
36	WS-021-07	Washer	8
37	NS-047-97	Nut ⁷ / ₁₆ -14 Hex	4
38	-	Cover – Adjusting (No Longer Available)	2
39	NS-031-15	Stop Nut 10-24 Hex (SST)	2
40	00-435701-00001	Angle Fitting Natural Gas #20 Drill (.161)	1
41	00-435701-00002	Angle Fitting L.P. Gas #43 Drill (.089)	1
42	00-435836-00002	Tube – Aluminum (2 ¹ / ₈ Lg.)	1
43	00-435836-00001	Tube – Aluminum (2 ¹ / ₄ Lg.) (Nat. Gas)	1
44	00-063262-00034	Flange & Nipple (Dim. 1 ⁵ / ₁₆)	1
45	00-063262-00033	Flange & Nipple (Dim. 2 ¹ / ₁₆) (Nat. Gas)	1
46	00-063262-00032	Flange & Nipple	1
47	SC-041-17	Cap Screw ⁵ / ₁₆ -18 x 1 ¹ / ₂ Hex Hd. (SST)	2
48	WS-017-08	Washer	4
49	WL-006-22	Lockwasher ⁵ / ₁₆ Light	2
50	NS-015-11	Nut ⁵ / ₁₆ -18 Hex	2
51	FP-028-07	Pipe Plug ¹ / ₄ Sq. Hd.	1
52	FP-086-62	Tee ³ / ₈ x ¹ / ₄ x ³ / ₈ Reducing	1
53	FP-086-63	Nipple ³ / ₈ x 1 ³ / ₈	1
54	00-435706-00001	Regulator – Natural Gas	1
55	00-435706-00002	Regulator – L.P. Gas	1
56	FP-035-58	Nipple ³ / ₈ x 2 ³ / ₄	1
57	FP-026-14	Bushing – ¹ / ₂ to ³ / ₈	1
*58	00-067500-00031	O-Ring	AR
*59	WS-003-47	Washer	AR
*60	NS-015-01	Nut ¹ / ₄ -20 Hex (SST)	AR
*61	WL-006-17	Lockwasher ¹ / ₄ Medium	AR
*62	00-119244-00002	Cap	AR
63	00-328649	Bracket – Orifice (Nat. Gas) (Shown) (Dim ¹ / ₂) (Marked NAT)	1
***64	00-436761	Bracket – Orifice (L.P. Gas Only) (Dim ¹ / ₂) (Marked LP)	1
65	00-435702	Connector – Male ⁷ / ₁₆	1
66	00-435762	Gasket	2
	00-508454	Sealer (¹ / ₈ Rd.)	AR
	00-526408	Foam Tape	AR
	00-546292	Sealer – Pipe	AR
	00-065890-00029	Connector – Insulated	2
	00-435538	Wire Harness – Ignitor Board	1

* Used on CRS76A, 66A/AW or CPW90A, 80A/AW machines in place of Item 26 in wash tank.
 ** No Longer Available. Order Items 1, 2, 6, 10, 40, 43, 45, 63, 65, & Part No. 436065 (Restrictor Plate) to convert to present style Natural Gas Heat System.
 *** Orifice bracket used previously on Nat. & L.P. Gas Heat Machines prior to serial #: C44A, 12-140-700; CRS66A, 12-139-031; CPW80A, 12-140-700. To convert to present style for Natural Gas only, order orifice bracket 328649.
 **** Orifice bracket used on L.P. Gas Heat machines after serial #: C44A, 12-140-700; CRS66A, 12-139-031; CPW80A, 12-140-700.

vsezip.ru

+7(812)987-08-81

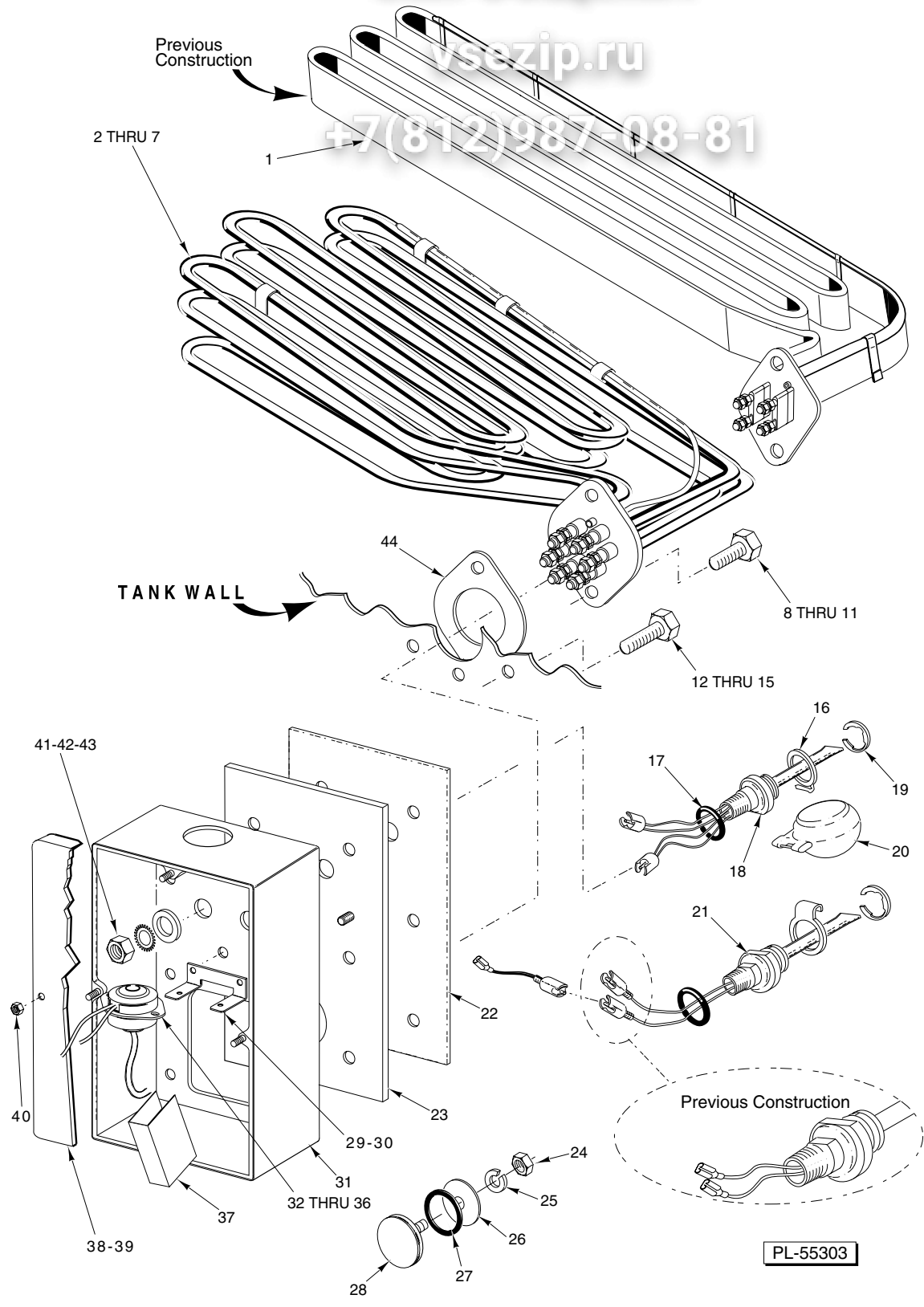

ELECTRIC HEAT

PL-55303

vsezip.ru

ELECTRIC HEAT

+7(812)987-08-81

ILLUS.	PART NO.	NAME OF PART	AMT.
PL-55303			
**1	-	Heater – Tank Electric (Flat Ribbon Type) (Not Available; See ** Below)	AR
2	00-435990-00001	Heater – Tank Electric (208 V., 60 Hz./200 V., 50 Hz.) (3 Ph.)	1
3	00-435990-00002	Heater – Tank Electric (240 V., 50/60 Hz.) (3Ph.)	1
4	00-435990-00003	Heater – Tank Electric (208 V., 60 Hz./200 V., 50 Hz.) (1 Ph.)	1
5	00-435990-00004	Heater – Tank Electric (240 V., 50/60 Hz.) (1 Ph.)	1
6	00-435990-00005	Heater – Tank Electric (480 V., 60 Hz.) (3 Ph.)	1
7	00-435990-00006	Heater – Tank Electric (380 V., 50 Hz.) (3 Ph.)	1
8	SC-041-13	Cap Screw ⁵ / ₁₆ -18 x 1 Hex Hd. (SST)	2
9	WS-017-08	Washer	2
10	WL-006-23	Lockwasher ⁵ / ₁₆ Medium (SST)	2
11	NS-015-11	Nut ⁵ / ₁₆ -18 Hex	2
12	SC-041-13	Cap Screw ⁵ / ₁₆ -18 x 1 Hex Hd. (SST)	6
13	WS-029-05	Washer	12
14	WL-006-23	Lockwasher ⁵ / ₁₆ Medium (SST)	6
15	NS-015-11	Nut ⁵ / ₁₆ -18 Hex	6
16	00-112467	Retainer – Float	AR
17	00-067500-00072	O-Ring	AR
18	00-186091	Probe & Switch Assy. (4 Wire) (Temperature & Water Level) (Incls. Items 16, 19, & 20)	1
19	RR-010-13	Retaining Ring	AR
20	00-122674	Float Assy.	AR
***21	00-328495	Probe & Switch Assy. (2 Wire) (Water Level) (Incls. Items 16, 19, & 20)	AR
22	00-271109	Gasket – Mounting	1
23	00-271118-00001	Plate – Mounting	1
*24	NS-015-01	Nut ¹ / ₄ -20 Hex (SST)	AR
*25	WL-006-17	Lockwasher ¹ / ₄ Medium	AR
*26	WS-003-47	Washer	AR
*27	00-067500-00031	O-Ring	AR
*28	00-119244-00002	Cap	AR
29	00-271122	Bracket – Thermostat	1
30	NS-031-15	Stop Nut 10-24 Hex (SST)	2
31	00-474512-00001	Box – Electric Heat	1
32	00-293946	Sleeve – Lead	1
33	00-271123	Protector – High Limit (Order Item 37 As Required)	1
34	SC-021-08	Mach. Screw 6-32 x ³ / ₈ Rd. Hd. (SST)	2
35	NS-031-50	Stop Nut 6-32 Hex (SST)	2
36	00-328758	Jumper Wire – Socket-Type Connector (Use W/Item 33)	2
37	00-271168	Insulator – Terminal (Above 250 V.)	1
38	00-474574-00002	Lid Assy. (Incls. Item 39)	1
39	00-474569	Gasket – Electric Heat Box	1
40	NS-031-15	Stop Nut 10-24 Hex (SST)	6
41	WS-010-40	Washer – Thrust	AR
42	WL-014-31	Lockwasher ¹ / ₂ External Shakeproof (SST)	AR
43	NS-018-28	Jam Nut ¹ / ₂ -20 Hex	AR
44	00-293598	Gasket – Heater Mounting	1
	00-526454	Foam Tape	AR
	00-545595	Sealer (¹ / ₈ Rd.)	AR
	00-294357-00001	Housing – Connector (Nat)	AR
	00-294357-00002	Housing – Connector (Black)	AR
	00-065890-00029	Connector – Insulated	2

* Used on CRS76A, CRS66A/AW, CPW90A, or CPW80A/AW machines in place of Item 21 in wash tank.

** Order tubular-type heater, Items 2 thru 7, as required & either wiring kit 436074 (3 Ph.) or wiring kit 436075 (1 Ph.).

*** Must order two jumper wires, Part #328758.

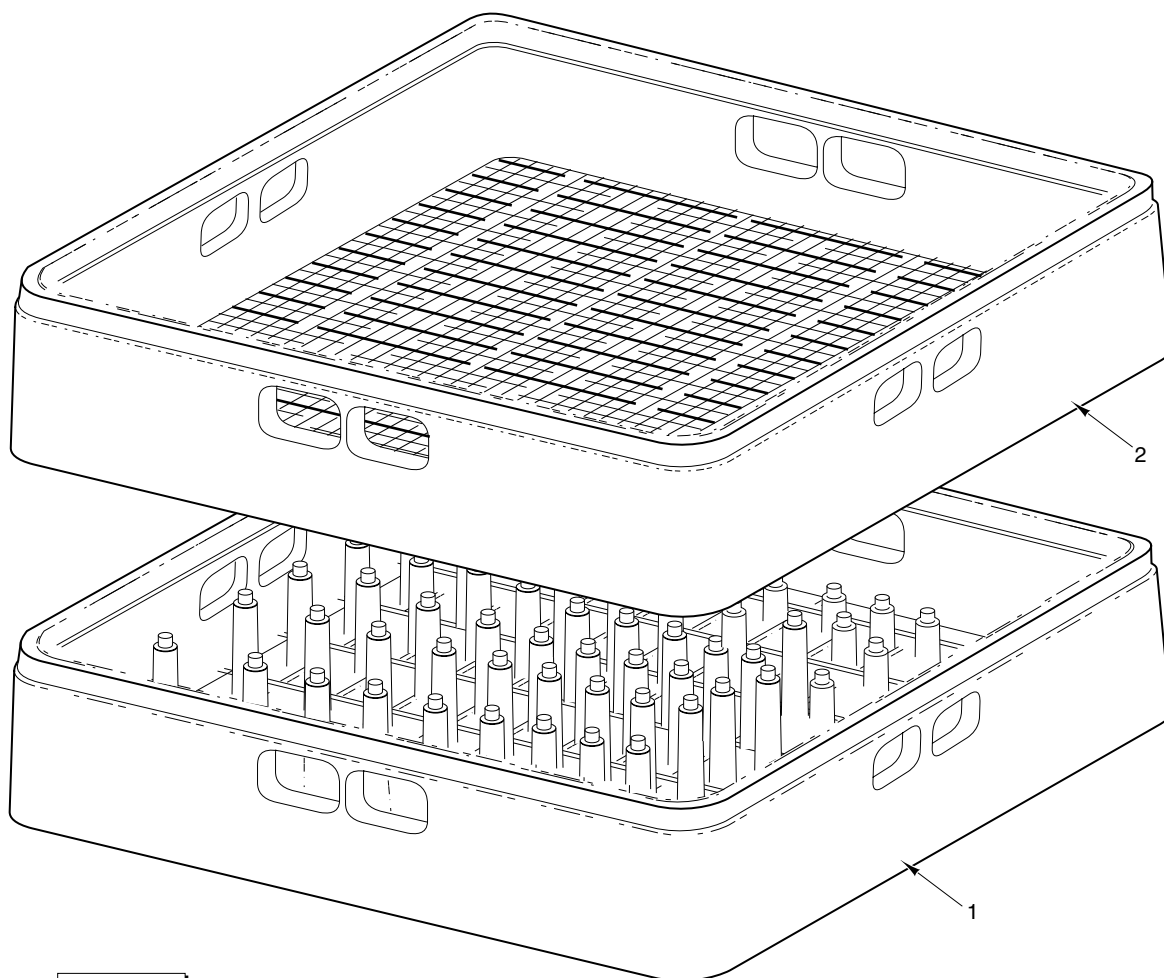

PL-51083

DISH RACKS

311 06 00 01 11

vsezip.ru

+7(812)987-08-81

DISH RACKS

ILLUS.	PART NO.	NAME OF PART	AMT.
PL-51083			
1	00-315191	Rack – Peg (Packaged)	1
2	00-315193	Rack – Combination (Packaged)	1
	00-295288	Peg Type Tray Rack (P1400)	1
	00-295372	Rack Assy. (250TX) (Tray & Bun Pans) (Packaged)	1

Всё.zip.ру

vsezip.ru

+7(812)987-08-81