

Зип Общепит

vsezip.ru

DESPIECE TECNICO

+7(812)987-08-81

**Freidoras
Fryers
Friteuse
Fritteusen
Friggitrici
Fritadeiras**

GAMA 700

Modelos:

FG7-05

FG7-10

FE7-05

FE7-10

Junio 2008 June

Revisado Marzo 2014 March Revised

FAGOR 

F A G O R I N D U S T R I A L

Зип Общепит

vsezip.ru

+7(812)987-08-81

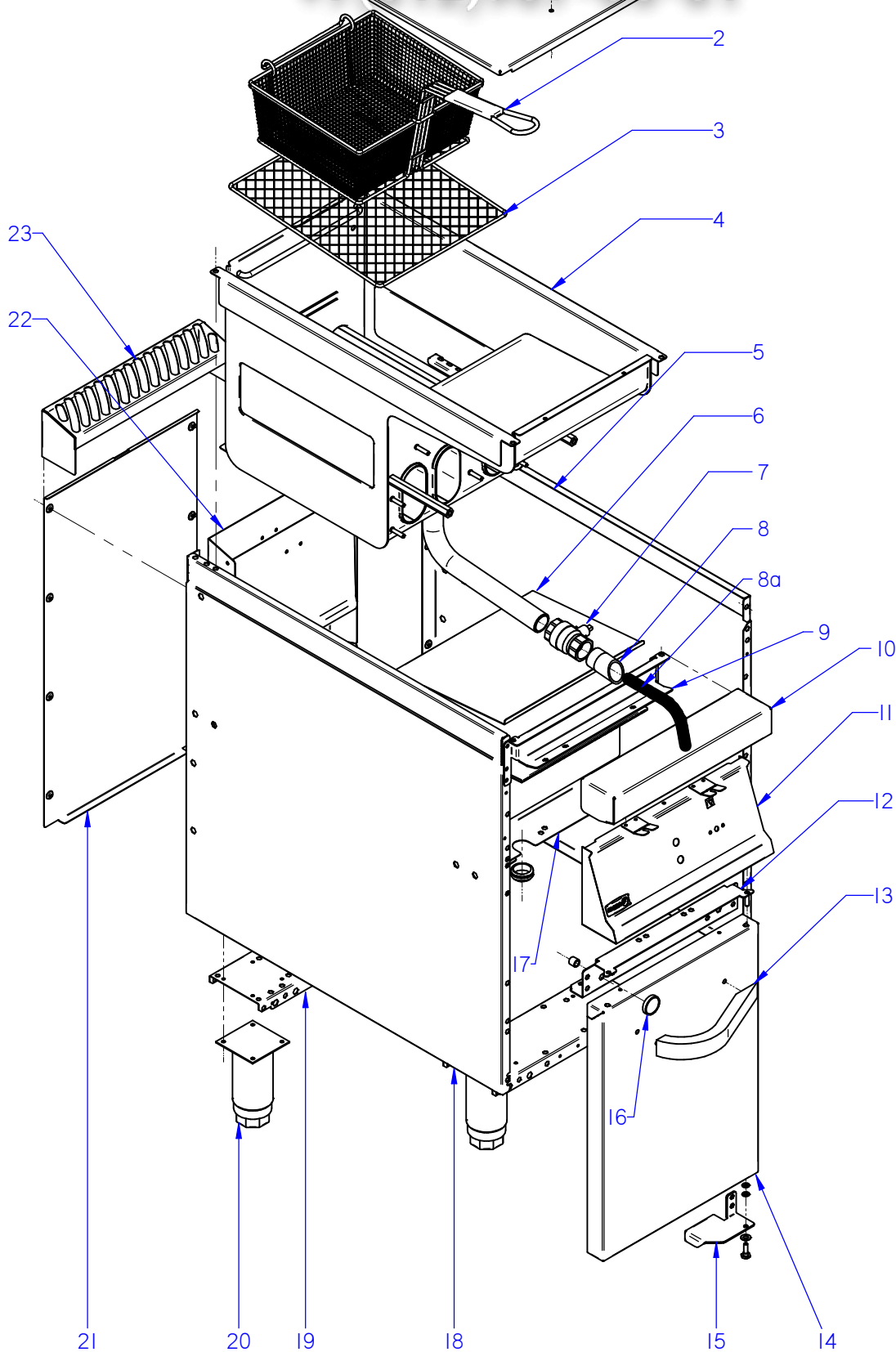

ITEM MARCADO EN COLOR = REPUESTO RECOMENDADO
COLOURED ITEM = RECOMMENDED SPARE PART

N plano	Firma	Fecha	Aparato	MUEBLE	Lamina	Fagor Industrial S.Coop. FAGOR
C-2091	<i>(Signature)</i>	2008-06	FREIDORA G-700		1	Oñate

Зип Общепит

MOD.		FREIDORAS		vsezip.ru		MUEBLE			
ITEM	CODIGO	DENOMINACION	TEXTO	FG7-05 1C	FG7-05 2C	FG7-10 2C	FG7-10 4C		
1	X606110000	TAPA FG-700	COVER FG-700	1	1	2	2		
	X166154000	POMO PARA TAPA	COVER KNOB	1	1	2	2		
	Q152004000	TORNIL. APLASTADO M5X13 A 304	FLAT HEADED SCREW M5x13 A 3	1	1	2	2		
2	X316531000	CESTILLO GRANDE G700	LARGE BASKET G700	1		2			
2	X316532000	CESTILLO PEQUEÑO G700	SMALL BASKET G700		2		4		
3	X316502000	REJILLA COMPLETA	COMPLETE GRILLE	1	1	2	2		
4	X606104000	CUBA COMPLETA FG-705	COMPLETE TUB FG-705	1	1	2	2		
	X316111000	AISLANTE 360X360X20 AL2C	INSULATION 360X360X20 AL2C	1	1	2	2		
	Q012031000	TORNILLO EXAGONAL M5X10 A.304	HEXAGONAL BOLT M5X10 A.304	4	4	8	8		
5	U912802000	PANEL LATERAL DCHO. G700	RIGHT SIDE PANEL G700	1	1	2	2		
	Q221342000	REMACHE EXAGONAL M5	HEXAGONAL RIVET M5	6	6	12	12		
	Q221343000	REMACHE EXAGONAL M6	HEXAGONAL RIVET M6	11	11	22	22		
6	X606109000	CHAPA PROTECCION CUBA G700	TUB PROTECTION PLATE G700	1	1	2	2		
	Q163040000	TUERCA EXAGONAL M6 LATON	HEXAGONAL NUT M6 BRASS	3	3	6	6		
	Q302022000	ARANDELA 16X6X1.2 A.304	WASHER 16X6X1.2 A.304	3	3	6	6		
7	X036107000	VALVULA ESFERA PASO TOTAL 1	SPHERICAL VALVE TOTAL PASS	1	1	2	2		
8	X506129000	PUNTA DESAGÜE (CUBA LIMPIA)	DRAINAGE POINT (CLEAN TUB)	1	1	2	2		
8a	11000006	TUBO SILICONA BAJA Tª D 38*31	SILICONE PIPE Tª D 38 * 31	1	1	2	2		
9	X602606000	ESCUADRA AMARRE ANTER. FG7-	FRONT FASTENING BRACKET FG	1	1	2	2		
	Q221342000	REMACHE EXAGONAL M5	HEXAGONAL RIVET M5	5	5	10	10		
	Q012031000	TORNILLO EXAGONAL M5X10 A.304	HEXAGONAL BOLT M5X10 A.304	6	6	12	12		
10	H125403000	ANTERIOR MESA 1/2M G-700	FRONT BENCH 1/2M G-700	1	1				
10	H125409000	ANTERIOR MESA 1M G-700	FRONT BENCH 1M G-700			1	1		
	Q152004000	TORNIL. APLASTADO M5X13 A 304	FLAT HEADED SCREW M5x13 A 3	2	2	4	4		
	Q302022000	ARANDELA 16X6X1.2 A.304	WASHER 16X6X1.2 A.304	2	2	4	4		
11	X602802000	PORTAMANDOS COMP. FG-705	COMP. CONTROL HOLDER FG-70	1	1				
11	X602804000	PORTAMANDOS COMP. FG-710	COMP. CONTROL HOLDER FG-71			1	1		
	Q152004000	TORNIL. APLASTADO M5X13 A 304	FLAT HEADED SCREW M5x13 A 3	2	2	4	4		
	Q302022000	ARANDELA 16X6X1.2 A.304	WASHER 16X6X1.2 A.304	2	2	4	4		
	U912805000	ESCUDO FAGOR G700	FAGOR EMBLEM G700	1	1	1	1		
	Q221023000	CLIP SUJECIÓN RÁPIDA Ø5	RAPID CONNECT CLIP Ø5	2	2	2	2		

Зип Общепит

vsezip.ru

+7(812)987-08-81

MOD.		FREIDORAS		MUEBLE			
ITEM	CODIGO	DENOMINACION	TEXTO	FG7-05 1C	FG7-05 2C	FG7-10 2C	FG7-10 4C
12	X602603000	LISTON BISAGRA SUPERIOR DCHA	UPPER RIGHT HINGE STRIP	1	1	1	1
S/Nº	X602610000	LISTON BISAGRA SUPERIOR IZDA.	UPPER LEFT HINGE STRIP	1	1	1	1
	Q221342000	REMACHE EXAGONAL M5	HEXAGONAL RIVET M5	7	7	12	12
	Q152004000	TORNIL. APLASTADO M5X13 A 304	FLAT HEADED SCREW M5x13 A 304	2	2	4	4
13	U910506000	ASA ARMARIO COMPLETO G700	FULL CUPBOARD HANDLE G700	1	1	2	2
	Q162040000	TUERCA EXAGONAL M6	HEXAGONAL NUT M6	2	2	4	4
	Q232040000	ARANDELA A6	WASHER A6	2	2	4	4
14	U910503000	PUERTA LATERAL G700	SIDE DOOR G700	1	1	2	2
	U910504000	CONTRAPUERTA LATERAL G 700	SIDE DOOR REVERSE G 700	1	1	2	2
	Q419005000	REMACHE 4X8 ALMG3 / ALUMINIO	RIVET 4X8 ALMG3 / ALUMINIUM	4	4	8	8
15	U020511000	BISAGRA DERECHA INFERIOR	LOWER RIGHT HINGE	1	1	1	1
	U020517000	BISAGRA IZQUIERDA INFERIOR	LEFT LOWER HINGE	1	1	1	1
	X960504000	TORNILLO DE GIRO M8	ROTATION BOLT M8	1	1	2	2
	Q232040000	ARANDELA A6	WASHER A6	2	2	4	4
	Q232050000	ARANDELA A8	WASHER A8	1	1	2	2
	Q221342000	REMACHE EXAGONAL M5	HEXAGONAL RIVET M5	2	2	4	4
16	X960501000	IMAN	MAGNET	1	1	2	2
	X960502000	FIJACION IMAN	MAGNET ATTACHMENT	1	1	2	2
	Q012021000	TORNILLO EXAGONAL M4X10	HEXAGONAL BOLT M4x10	1	1	2	2
17	X612603000	CHAPA PROTECC. TERMOSTATO	THERMOSTAT PROTECTION PLATE	1	1	2	2
	Q221342000	REMACHE EXAGONAL M5	HEXAGONAL RIVET M5	2	2	4	4
	X723014000	PASAMUROS Ø 30	WALL BUSHING Ø 30	2	2	2	2
18	U912801000	PANEL LATERAL IZDO. G700	LEFT SIDE PANEL G700	1	1	2	2
	Q221342000	REMACHE EXAGONAL M5	HEXAGONAL RIVET M5	6	6	12	12
	Q221343000	REMACHE EXAGONAL M6	HEXAGONAL RIVET M6	4	4	8	8
	Q221343000	REMACHE EXAGONAL M6	HEXAGONAL RIVET M6	7	7	14	14
19	X602601000	LISTON SOPORTE PATAS FG7-05	LEG SUPPORT STRIP FG7-05	2	2	—	—
19	X602609000	LISTON SOPORTE PATAS FG7-10	LEG SUPPORT STRIP FG7-10	—	—	2	2
	Q221343000	REMACHE EXAGONAL M6	HEXAGONAL RIVET M6	4	4	4	4
20	X260151000	PATA REGULABLE	ADJUSTABLE LEG	4	4	4	4
	Q411304000	REMACHE AVIBULB Ø 4,8	AVIBULB RIVET Ø 4.8	16	16	16	16

Зип Общепит

vsezip.ru

+7(812)987-08-81

MOD.	FREIDORAS	MUEBLE					
ITEM	CODIGO	DENOMINACION	TEXTO	FE7-05 1C	FE7-05 2C	FE7-10 2C	FE7-10 4C
1	X616106000	TAPA FE-700	COVER FE-700	1	1	2	2
	X166154000	POMO PARA TAPA	COVER KNOB	1	1	2	2
	Q152004000	TORNIL. APLASTADO M5X13 A 304	FLAT HEADED SCREW M5x13 A 304	1	1	2	2
2	X316531000	CESTILLO GRANDE G700	LARGE BASKET G700	1	-	2	-
2	X316532000	CESTILLO PEQUEÑO G700	SMALL BASKET G700	-	2	-	4
3	X616501000	REJILLA FE7-00	GRILLE FE7-00	1	1	2	2
4	X616104000	CUBA COMPLETA FE-700	COMPLETE TUB FE-700	1	1	2	2
	Q012031000	TORNILLO EXAGONAL M5X10 A.304	HEXAGONAL BOLT M5X10 A.304	4	4	8	8
5	U912802000	PANEL LATERAL DCHO. G700	RIGHT SIDE PANEL G700	1	1	2	2
	Q221342000	REMACHE EXAGONAL M5	HEXAGONAL RIVET M5	6	6	12	12
	Q221343000	REMACHE EXAGONAL M6	HEXAGONAL RIVET M6	4	4	8	8
	Q221343000	REMACHE EXAGONAL M6	HEXAGONAL RIVET M6	7	7	14	14
6	X606109000	CHAPA PROTECCION CUBA G700	TUB PROTECTION PLATE G700	-	-	-	-
7	X036107000	VALVULA ESFERA PASO TOTAL 1	SPHERICAL VALVE TOTAL PASS	1	1	2	2
8	X506129000	PUNTA DESAGÜE (CUBA LIMPIA)	DRAINAGE POINT (CLEAN TUB)	1	1	2	2
9	X602606000	ESCUADRA AMARRE ANTER. FG7-	FRONT FASTENING BRACKET FG7-	1	1	2	2
	Q221342000	REMACHE EXAGONAL M5	HEXAGONAL RIVET M5	5	5	10	10
	Q012031000	TORNILLO EXAGONAL M5X10 A.304	HEXAGONAL BOLT M5X10 A.304	6	6	12	12
10	H125403000	ANTERIOR MESA 1/2M G-700	FRONT BENCH 1/2M G-700	1	1	-	-
10	H125409000	ANTERIOR MESA 1M G-700	FRONT BENCH 1M G-700	-	-	1	1
	Q152004000	TORNIL. APLASTADO M5X13 A 304	FLAT HEADED SCREW M5x13 A 304	2	2	4	4
	Q302022000	ARANDELA 16X6X1.2 A.304	WASHER 16X6X1.2 A.304	2	2	4	4
11	X602802000	PORTAMANDOS COMP. FG-705	COMP. CONTROL HOLDER FG-705	1	1	-	-
11	X602804000	PORTAMANDOS COMP. FG-710	COMP. CONTROL HOLDER FG-710	-	-	1	1
	Q152004000	TORNIL. APLASTADO M5X13 A 304	FLAT HEADED SCREW M5x13 A 304	2	2	4	4
	Q302022000	ARANDELA 16X6X1.2 A.304	WASHER 16X6X1.2 A.304	2	2	4	4
	U912805000	ESCUDO FAGOR G700	FAGOR EMBLEM G700	1	1	1	1
	Q221023000	CLIP SUJECIÓN RÁPIDA Ø5	RAPID CONNECT CLIP Ø5	2	2	2	2

Зип Общепит

vsezip.ru

+7(812)987-08-81

MOD.		FREIDORAS		MUEBLE			
ITEM	CODIGO	DENOMINACION	TEXTO	FE7-05 1C	FE7-05 2C	FE7-10 2C	FE7-10 4C
12	X602603000	LISTON BISAGRA SUPERIOR DCHA	UPPER RIGHT HINGE STRIP	1	1	1	1
S/Nº	X602610000	LISTON BISAGRA SUPERIOR IZDA.	UPPER LEFT HINGE STRIP	1	1	1	1
	Q221342000	REMACHE EXAGONAL M5	HEXAGONAL RIVET M5	7	7	12	12
	Q152004000	TORNIL. APLASTADO M5X13 A 304	FLAT HEADED SCREW M5x13 A 304	2	2	4	4
13	U910506000	ASA ARMARIO COMPLETO G700	FULL CUPBOARD HANDLE G700	1	1	2	2
	Q162040000	TUERCA EXAGONAL M6	HEXAGONAL NUT M6	2	2	4	4
	Q232040000	ARANDELA A6	WASHER A6	2	2	4	4
14	U910503000	PUERTA LATERAL G700	SIDE DOOR G700	1	1	2	2
	U910504000	CONTRAPUERTA LATERAL G 700	SIDE DOOR REVERSE G 700	1	1	2	2
	Q419005000	REMACHE 4X8 ALMG3 / ALUMINIO	RIVET 4X8 ALMG3 / ALUMINIUM	4	4	8	8
15	U020511000	BISAGRA DERECHA INFERIOR	LOWER RIGHT HINGE	1	1	1	1
	U020517000	BISAGRA IZQUIERDA INFERIOR	LEFT LOWER HINGE	1	1	1	1
	X960504000	TORNILLO DE GIRO M8	ROTATION BOLT M8	1	1	2	2
	Q232040000	ARANDELA A6	WASHER A6	2	2	4	4
	Q232050000	ARANDELA A8	WASHER A8	1	1	2	2
	Q221342000	REMACHE EXAGONAL M5	HEXAGONAL RIVET M5	2	2	4	4
16	X960501000	IMAN	MAGNET	1	1	2	2
	X960502000	FIJACION IMAN	MAGNET ATTACHMENT	1	1	2	2
	Q012021000	TORNILLO EXAGONAL M4X10	HEXAGONAL BOLT M4x10	1	1	2	2
17	X612603000	CHAPA PROTECC. TERMOSTATO	THERMOSTAT PROTECTION PLA	1	1	2	2
	Q221342000	REMACHE EXAGONAL M5	HEXAGONAL RIVET M5	2	2	4	4
	X723014000	PASAMUROS Ø 30	WALL BUSHING Ø 30	1	1	2	2
18	U912801000	PANEL LATERAL IZDO. G700	LEFT SIDE PANEL G700	1	1	2	2
	Q221342000	REMACHE EXAGONAL M5	HEXAGONAL RIVET M5	6	6	12	12
	Q221343000	REMACHE EXAGONAL M6	HEXAGONAL RIVET M6	4	4	8	8
	Q221343000	REMACHE EXAGONAL M6	HEXAGONAL RIVET M6	7	7	14	14
19	X602601000	LISTON SOPORTE PATAS FG7-05	LEG SUPPORT STRIP FG7-05	2	2	1	1
19	X602609000	LISTON SOPORTE PATAS FG7-10	LEG SUPPORT STRIP FG7-10	1	1	2	2
	Q221343000	REMACHE EXAGONAL M6	HEXAGONAL RIVET M6	4	4	4	4
20	X260151000	PATA REGULABLE	ADJUSTABLE LEG	4	4	4	4
	Q411304000	REMACHE AVIBULB Ø 4,8	AVIBULB RIVET Ø 4.8	16	16	16	16

Зип Общепит

vsezip.ru

+7(812)987-08-81

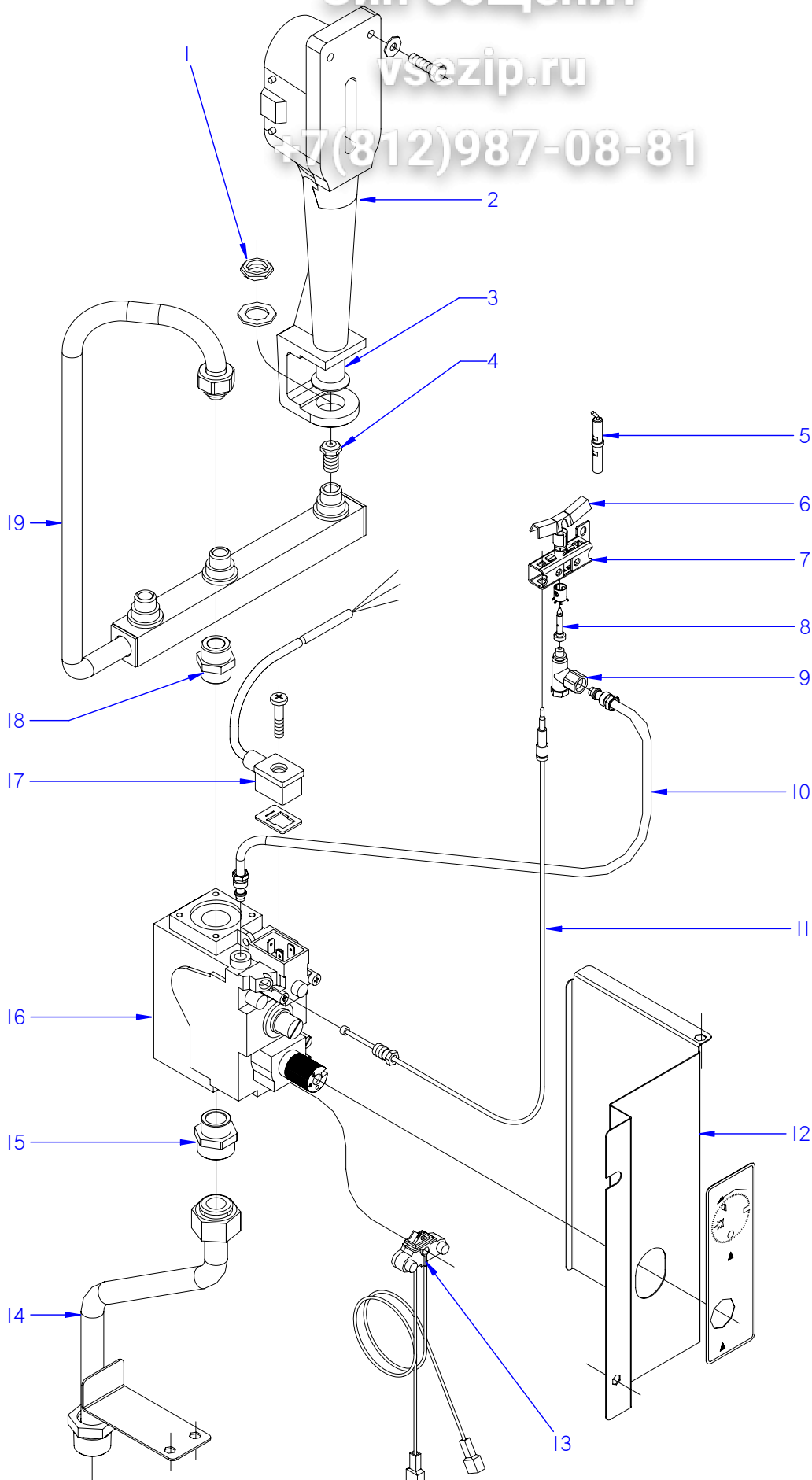

ITEM MARCADO EN COLOR = REPUESTO RECOMENDADO
COLOURED ITEM = RECOMMENDED SPARE PART

N plano	Firma	Fecha	Aparato	PARTE FUNCIONAL GAS	Lamina	Fagor Industrial S.Coop. FAGOR
C-2092	<i>(Signature)</i>	2008-06	FREIDORA FG7-05 / FG7-10		2	Oñate

Зип Общепит

MOD.

FREIDORAS

vsezip.ru

PARTE FUNCIONAL GAS

ITEM	CODIGO	DENOMINACION	TEXTO	FG7-05	FG7-10			
1	Q223021000	TUERCA EXAGONAL 15x1	HEXAGONAL NUT 15x1	3	6			
	Q301322000	ARANDELA PLANA 27x17x2	FLAT WASHER 27x17x2	3	6			
2	X015700000	QUEMADOR COMPLETO FG9-00	COMPLETE BURNER FG9-00	3	6			
	Q012043000	TORNILLO EXAGONAL M6x20 A304	HEXAGONAL BOLT M6x20 A304	6	12			
	Q302022000	ARANDELA 16x6x1,2 A.304	WASHER 16X6X1.2 A.304	6	12			
3	U325707000	REGULADOR DE AIRE	AIR REGULATOR	3	6			
	Q012031000	TORNILLO EXAGONAL M5X10 A304	HEXAGONAL BOLT M5x10 A304	3	6			
4	X312400000	TOBERA Ø 1,10 (BUTANO-PROP.)	NOZZLE Ø1.10 (BUT-PROP.)	3	6			
4	N502401000	TOBERA Ø 1,70 (GAS NATURAL)	NOZZLE Ø1.70 (GAS NATURAL)	3	6			
5	X012101000	BUJIA 915.037	SPARK PLUG 915.037	1	2			
6	X012117000	PILOTO	PILOT	1	2			
7	X012113000	AMARRE TRAS. PILOTO 978.003	REAR FASTENING PILOT 978.003	1	2			
	X012114000	AMARRE DELANT. PILOTO 978.004	FRONT FASTENING PILOT 978.004	1	2			
S/N	X012122000	REGULADOR DE AIRE 912.001	AIR CONTROL 912.001	1	2			
8	U442137000	INYECTOR Ø 0.4 (GAS NATURAL)	NOZZLE Ø0.4 (GAS NATURAL)	1	2			
9	X012126000	CUERPO SIN RAC. 901.210 (B-P)	BODY WITHOUT CONNEC. 901.210	1	2			
9	U442136000	CUERPO SIN RACORD (G-N)	BODY WITHOUT CONNEC. (G-N)	1	2			
	X012116000	TORNILLO AMARRE PILOTO	PILOT FASTENING BOLT	2	4			
10	X605007000	TUBO PILOTO COMPL FG-705	COMPL PILOT PIPE FG-705	1	2			
11	U562130000	TERMOPAR L=850	THERMOCOUPLE L=850	1	2			
12	X602607000	CHAPA PROT. ELECTROVALVULA	SOLENOID VALVE PROT. PLATE	1	2			
	X162617000	PEGATINA POSICION MANDO	CONTROL POSITION STICKER	1	2			
	Q221342000	REMACHE EXAGONAL M5	HEXAGONAL RIVET M5	1	2			
13	R275027000	CABLEADO ELECTROSIT 927.012	WIRING ELECTROSIT 927.012	1	2			
14	X605004000	ENTRADA GAS COMPL FG-705	COMPL GAS INPUT FG-705	1	2			
	Q306052000	ARANDELA Ø23,5x15,5x3	WASHER Ø23.5X15.5X3	1	2			
15	S502106000	MANGUITO DOBLE 3/4"- 1/2"	DOUBLE SLEEVE 3/4"- 1/2"	1	2			
15	12046984	MANGUITO 1/2"-3/4"	SLEEVE 3/4"- 1/2"	1	2			
	Q306013000	ARANDELA PLANA Ø30.4X22.4X3	FLAT WASHER Ø30.4X22.4X3	1	2			
16	12097292	VALVULA NOVA 820 REGULADA	VALVE REGULATED NOVA 820	1	2			
16	12024777	ELECTROVALV. 820 NOVA 60 Hz.	SOLENOID VALVE. 820 NOVA 60 Hz.	1	2			

Зип Общепит

vsezip.ru

+7(812)987-08-81

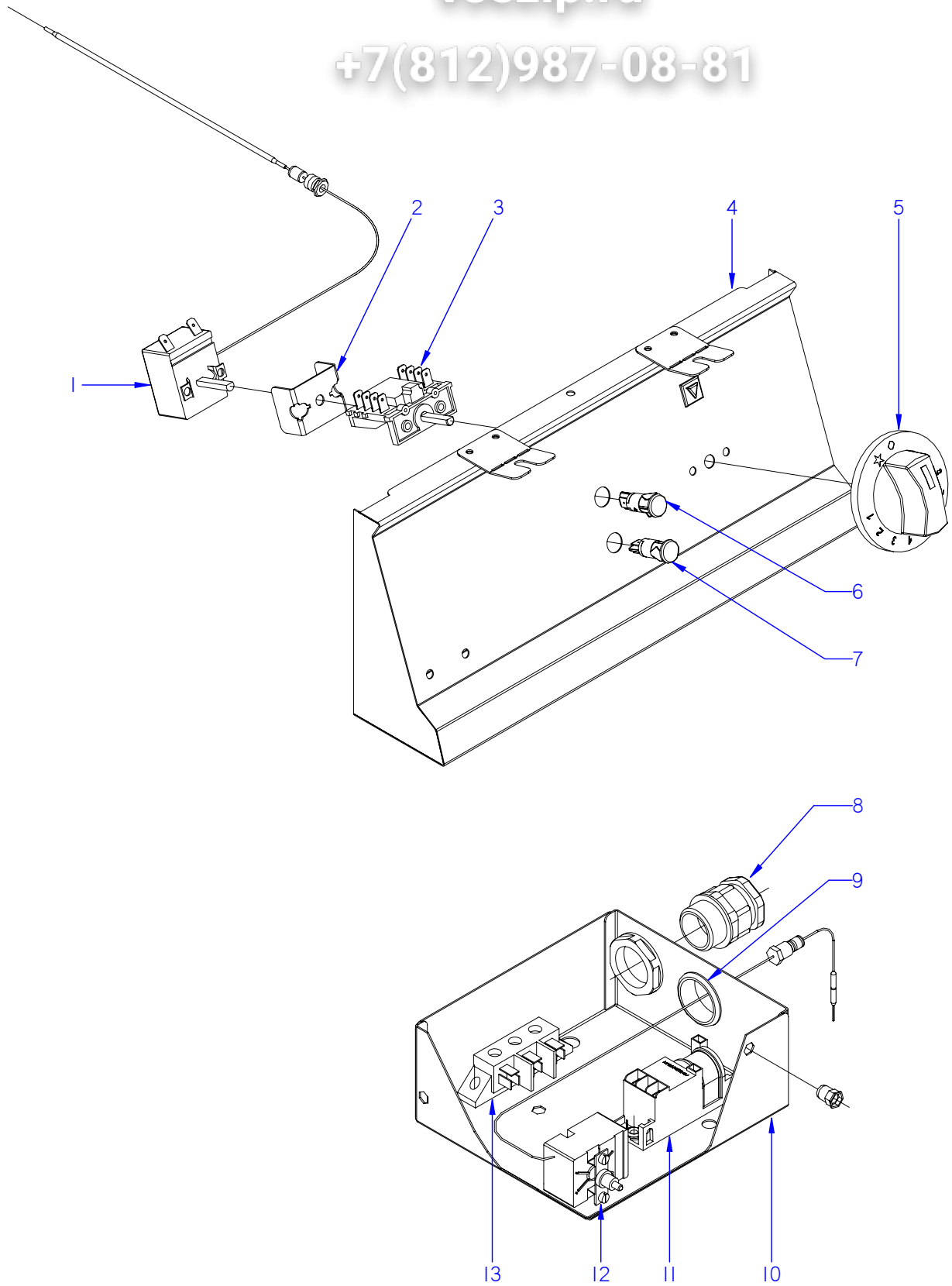

ITEM MARCADO EN COLOR = REPUESTO RECOMENDADO
COLOURED ITEM = RECOMMENDED SPARE PART

N plano	Firma	Fecha	Aparato	PARTE FUNCIONAL ELECTRICA	Lamina	Fagor Industrial S.Coop. FAGOR
C-2093	<i>(Signature)</i>	2008-06	FREIDORA FG7-05 / FG7-10	3	Oñate	

Зип Общепит

vsezip.ru

#(812)987-08-81

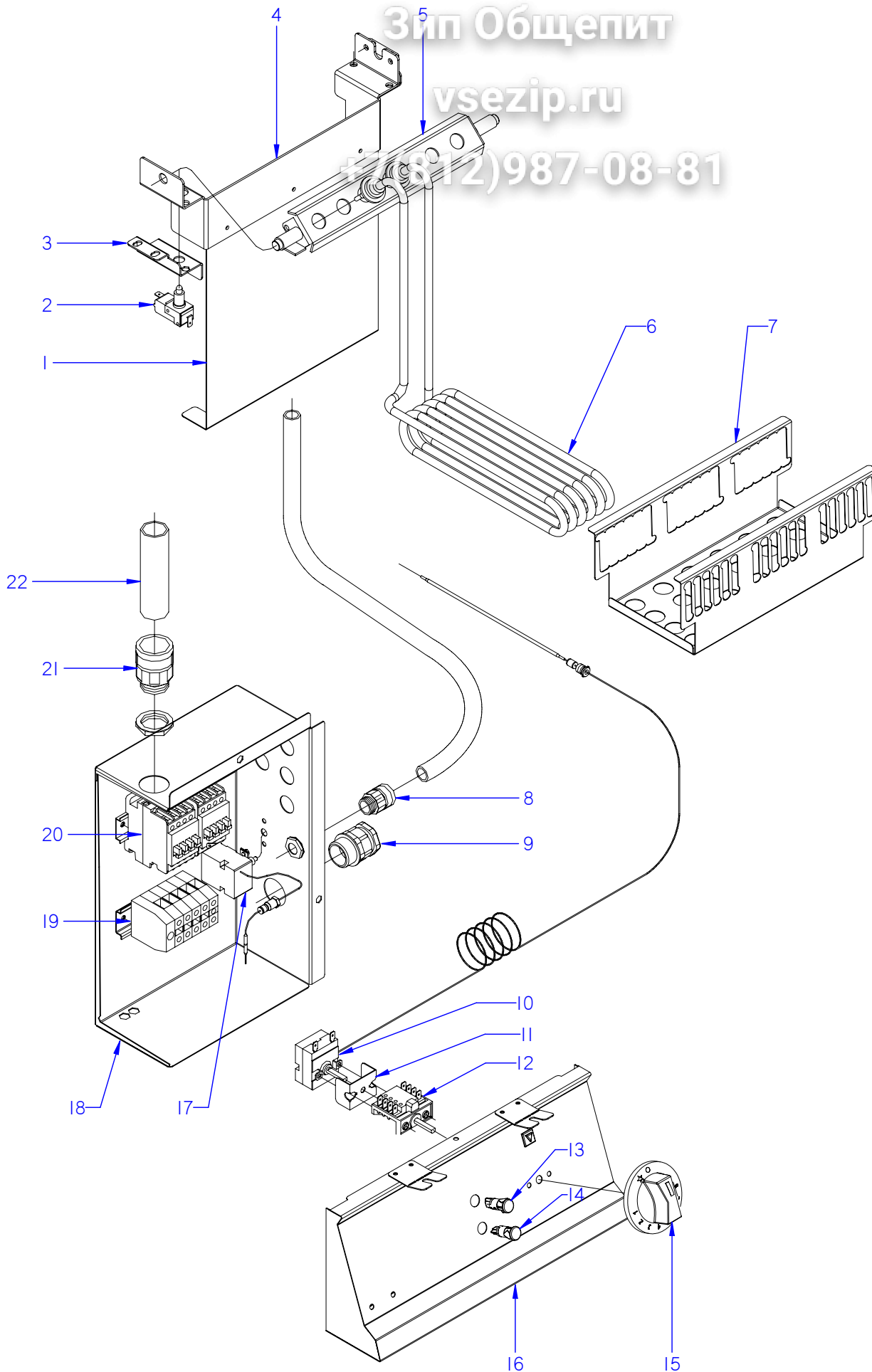

ITEM MARCADO EN COLOR = REPUESTO RECOMENDADO
COLOURED ITEM = RECOMMENDED SPARE PART

N plano	Firma	Fecha	Aparato	PARTE FUNCIONAL ELECTRICA	Lamina	Fagor Industrial S.Coop. FAGOR
C-2094	<i>(Signature)</i>	2008-06	FREIDORA FE7-05 / FE7-10		4	Oñate

MOD.	FREIDORAS ELECTRICAS	ZONA	PARTE FUNCIONAL ELECTRICA
-------------	-----------------------------	-------------	----------------------------------

ITEM	CODIGO	DENOMINACION	TEXTO	FE7-05	FE7-10			
1	X322620000	SUPLEMENTO GUIA CABLES	CABLE GUIDE SUPPLEMENT	1	2			
2	X343015000	MICRORRUPTOR COD.32280001	MICROSWITCH COD.32280001	1	2			
3	X612604000	ESCUADRA IZQUIERDO GIRO G700	LEFT ROTATION BRACKET G700	1	2			
	X612605000	ESCUADRA DERECHA GIRO G700	RIGHT ROTATION BRACKET G700	1	2			
	Q012031000	TORNILLO EXAGONAL M5X10 A304	HEXAGONAL BOLT M5x10 A304	6	12			
4	X322619000	SOPORTE GIRO RESISTENCIAS	RESISTOR ROTATION SUPPORT	1	2			
	Q419005000	REMACHE 4x8 ALMG3 / ALUMINIO	RIVET 4X8 ALMG3 / ALUMINIUM	6	12			
	Q012031000	TORNILLO EXAGONAL M5X10 A304	HEXAGONAL BOLT M5x10 A304	6	12			
5	X612602000	GIRO RESISTENCIAS COMPLETO	COMPLETE RESISTOR ROTATIO	1	2			
S/Nº	X322623000	ESCUADRA PROT. CONEXIONES	CONNECTION PROT. BRACKET	1	2			
	Q152004000	TORNILLO APLAST, M5x13 A304	FLAT HEADED BOLT M5x13 A304	2	4			
6	X613006000	RESISTENCIA IZQUIERDA	LEFT RESISTOR	1	2			
6	X323010000	RESISTENCIA IZQUIERDA	LEFT RESISTOR	1	2			
S/Nº	X613005000	RESISTENCIA DECHA.CENTRAL	RIGHT CENTRAL RESISTOR	2	4			
S/Nº	X323009000	RESISTENCIA DECHA.CENTRAL	RIGHT CENTRAL RESISTOR	2	4			
7	X613001000	CHAPA FIJACION RESIST. FE-700	RESISTOR FASTENING PLATE FE	1	2			
S/Nº	12020909	BRIDA ALTA TEMPERATURA 130°	CLAMP HIGH TEMPERATUR. 130	3	6			
8	X033027000	RACORD QUICK 5020.049.011	QUICK CONNECTION 5020.049.0	4	8			
	X033028000	CONTRATUERCA 790.1100.0	COUNTERNUT 790.1100.0	4	8			
9	R023013000	PRENSA ESTOPAS	STUFFING BOX	1	2			
	R023025000	CONTRATUERCA GAES	COUNTERNUT GAES	1	2			
	R023026000	JUNTA DE GOMA GAES	RUBBER SEAL GAES	1	2			
10	X163010000	TERMOSTATO	THERMOSTAT	1	2			
11	X313001000	U SOPORTE TERMOSTATO	THERMOSTAT U SUPPORT	1	2			
	Q151320000	TORNILLO ALOMADO M4x6 H,ZINC.	CURVED SCREW M4x6 H,ZINC.	2	4			
12	X163007000	CONMUTADOR ACOPLA TERMOS.	THERMOSTAT CONNECT SWITC	1	2			
13	R693055000	PILOTO VERDE 41227000C7	GREEN PILOT 41227000C7	1	2			
13	12047390	PILOTO VERDE 230V AC 8KW 16MM	GREEN PILOT 230V AC 8KW 16M	1	2			
14	R693056000	PILOTO AMBAR 41227000A4	AMBER PILOT 41227000A4	1	2			
14	12024669	PILOTO AMBAR Ø18	AMBER PILOT Ø18	1	2			
15	X613002000	BOTON DE MANDO Ø6 FE-700	CONTROL BUTTON Ø6 FE-700	1	2			

MOD.		FREIDORAS		ZONA		REPUESTOS RECOMENDADOS RECOMMENDED SPARE PART			
ITEM	CODIGO	DENOMINACION	TEXTO	FG7-05	FG7-10	FE7-05	FE7-10		
7	X036107000	VALVULA ESFERA PASO TOTAL 1	SPHERICAL VALVE TOTAL PASS	1	1	2	2		
5	X012101000	BUJIA 915.037	SPARK PLUG 915.037	1	2	-	-		
6	X012117000	PILOTO	PILOT	1	2	-	-		
7	X012113000	AMARRE TRAS. PILOTO 978.003	REAR FASTENING PILOT 978.003	1	2	-	-		
	X012114000	AMARRE DELANT. PILOTO 978.004	FRONT FASTENING PILOT 978.004	1	2	-	-		
S/N	X012122000	REGULADOR DE AIRE 912.001	AIR CONTROL 912.001	1	2	-	-		
8	U442137000	INYECTOR Ø 0.4 (GAS NATURAL)	NOZZLE Ø0.4 (GAS NATURAL)	1	2	-	-		
9	X012126000	CUERPO SIN RAC. 901.210 (B-P)	BODY WITHOUT CONNEC. 901.210	1	2	-	-		
9	U442136000	CUERPO SIN RACORD (G-N)	BODY WITHOUT CONNEC. (G-N)	1	2	-	-		
11	U562130000	TERMOPAR L=850	THERMOCOUPLE L=850	1	2	-	-		
13	R275027000	CABLEADO ELECTROSIT 927.012	WIRING ELECTROSIT 927.012	1	2	-	-		
14	X605004000	ENTRADA GAS COMPL FG-705	COMPL GAS INPUT FG-705	1	2	-	-		
	Q306052000	ARANDELA Ø23,5x15,5x3	WASHER Ø23.5X15.5X3	1	2	-	-		
16	12097292	VALVULA NOVA 820 REGULADA	VALVE REGULATED NOVA 820	1	2	-	-		
16	12024777	ELECTROVALV. 820 NOVA 60 Hz.	SOLENOID VALVE. 820 NOVA 60	1	2	-	-		
17	12046785	CABLE VALVULA GAS NOVA 960.015	VALVE GAS NOVA 960.015 CABL.	1	2	-	-		
1	X163010000	TERMOSTATO	THERMOSTAT	1	2	-	-		
3	X163007000	CONMUTADOR ACOUPLE TERMOS.	THERMOSTAT CONNECT SWITC	1	2	-	-		
6	12047390	PILOTO VERDE 230V AC 8KW 16MM	GREEN PILOT 230V AC 8KW 16M	1	2	-	-		
7	12024669	PILOTO AMBAR Ø18	AMBER PILOT Ø18	1	2	-	-		
11	X163014000	ENCENDEDOR PARA 2 BUJIAS	LIGHTER FOR 2 PLUGS	1	2	-	-		
12	12048400	TERMOSTATO SEGURIDAD 245°C U	SECURITY THERMOSTAT 245 °	1	2	-	-		
2	X343015000	MICRORRUPTOR COD.32280001	MICROSWITCH COD.32280001	-	-	1	2		
6	X323010000	RESISTENCIA IZQUIERDA	LEFT RESISTOR	-	-	1	2		
S/Nº	X323009000	RESISTENCIA DECHA.CENTRAL	RIGHT CENTRAL RESISTOR	-	-	2	4		
10	X163010000	TERMOSTATO	THERMOSTAT	-	-	1	2		
12	X163007000	CONMUTADOR ACOUPLE TERMOS.	THERMOSTAT CONNECT SWITC	-	-	1	2		
13	12047390	PILOTO VERDE 230V AC 8KW 16MM	GREEN PILOT 230V AC 8KW 16M	-	-	1	2		
14	12024669	PILOTO AMBAR Ø18	AMBER PILOT Ø18	-	-	1	2		
17	12048400	TERMOSTATO SEGURIDAD 245°C U	SECURITY THERMOSTAT 245 °	-	-	1	2		

Зип-Общепит

vsezip.ru

+7(812)987-08-81



K = Interruptor general
 L1 = Lámpara funcionamiento
 T = Termostato regulable (80-280°C)
 Ts = Limitador (245)
 L2 = Lámpara calentamiento
 E = Encendedor
 GV = Orificio válvula gas

m=maron-brown-marron
 n=negro-black-noir
 r=rojo-red-rouge
 b=blanco-white-blanc
 v=verde-green-vert
 g=gris-grey-gris
 a=azul-blue-bleu

X 163005

NOTAS:

- GRABACIONES: COLOR NEGRO
- FONDO: COLOR NATURAL
- LA PLACA SERA AUTOADHESIVA POR LA CARA POSTERIOR Y RECUBIERTO POR UN PAPEL PROTECTOR.
- LAS INSCRIPCIONES RESISTIRAN SIN MODIFICACION APRECIABLE, EL PROTAIMIENTO DURANTE 15 SEG. DE UN ALGODON EMPAPADO EN GASOLINA.

ALUMINIO BRILLO (SOLID-FOLI)
 e=ALUMINIO+PROTECTOR=0,2

Esquema teorico adhesivo FG-91,20			X 163005	
Nº	Pieza	Materia	Nº Clasificación	Acabado
Nº	Modificación	Propuesta de	FABOR	Tolerancias generales
1	Modificación general (pasar a fabrica inter.)	Plazapla	23-597	$5-10$ $5-25$: $50-100$ $25-50$: 100 $Ox.$
Dibujado	Firma	Fecha	 Fabor Industrial, R.o.p. E.K., Múgela	
Proyectado	JON	93-9-14		
Comprobado				
Escala				
FREIDORAS Para hacer cables cable controlado por termico gas			Mecanizado superficial Plano numero HB-14457-1 Sustituye al Nº Sustituido por	

Зип Общепит

vsezip.ru

+7(812)987-08-81

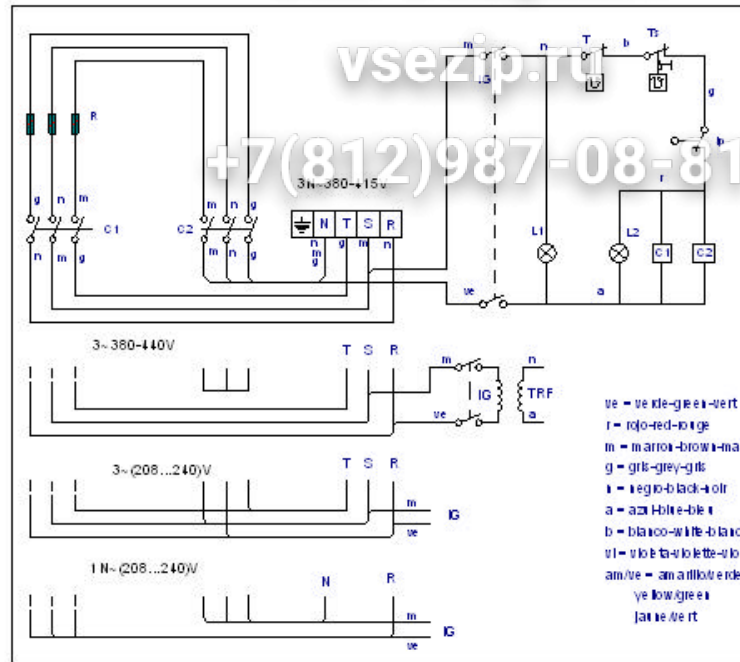

X183059

NOTAS

- Las inscripciones resistirán sin modificación apreciable el frotamiento durante 15 seg. de un algodón impregnado en gasolina.

Esquema teórico adhesivo		
Nº	Pieza	
Nº	Modificación	
⊕	Introducir texto componentes en placa.	
Dibujado		Fecha
Proyectado		23.6.98
Comprobado		
Escala		
1/1		FREID
Plano para el cableado de la placa		

Зип Общепит

vsezip.ru

+7(812)987-08-81

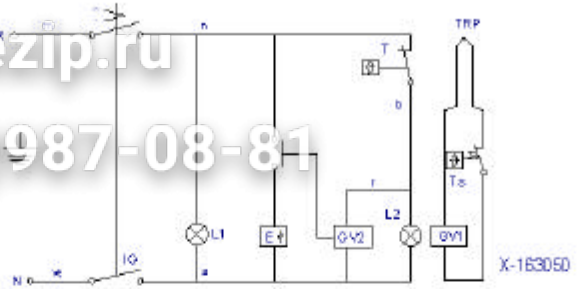

m=maron-brown-marron
 n=negro-black-noir
 r=rojo-red-rouge
 b=blanco-white-blanc
 v=verde-green-vert
 g=gris-grey-gris
 a=azul-blue-bleu

IG = Interruptor general
 L1 = Lámpara funcionamiento
 T = Termostato regulable (50-230C)
 Ts = Limitador (24h)
 L2 = Lámpara calentamiento
 E = Encendedor
 GV1 = Válvula gas (SEGURIDAD)
 GV2 = Válvula gas (CONTROL)
 TRP = Termopar

NOTA

- LAS INSCRIPCIONES RESISTIRAN SIN MODIFICACION
 APRECIABLE, EL FROTAMIENTO DURANTE 15 SEG. DE UN
 ALGODON EMPAPADO EN GASOLINA.

Plastico blanco alto brillo

Esquema teorico adhesivo FG-820 A		X-163050	
Nº	Pieza	Materia	Nº Clasificación
Nº	Modificación	Propuesta de	Fecha
1	Pasar de GV y VG a GV1 y GV2	Letona	97-1-18
2	Modific. general (pasar a fabric. interior)	Plazuela	97-4-23
			50-100
			5-25t : >100
			25-50t : >100
			OXt
Dibujado	Firma	Fecha	 Mecanizado superficial
Proyectado	JON	96-5-30	
Comprobado			
Escala			
FREIDORAS			Plano numero HB-70479
Plano homologado y certificado por fabricante gas			Sustituye al Nº Sustituido por