

Зип Общепит

vsezip.ru

DESPIECE TECNICO  
LISTE DE PIÉCES DÉTACHÉES  
SPARE PARTS LIST

Junio - 1994

## FREIDORAS GAMA 900

**Modelos:**

**FG-920**

**FG-940**

**FE-920**



**Proyectos e Instalaciones y S.A.T.**

Oñati, 16 de Mayo de 1994

Hostelería, Frío Comercial y Lavandería Industrial  
Grandes Cuisines, Froid Commercial et Buanderie  
Catering, Commercial Refrigeration and Laundry Equipment

**Fagor Industrial, S. Coop.**  
20560 - Oñati - España





Зип Общепит

vsezip.ru

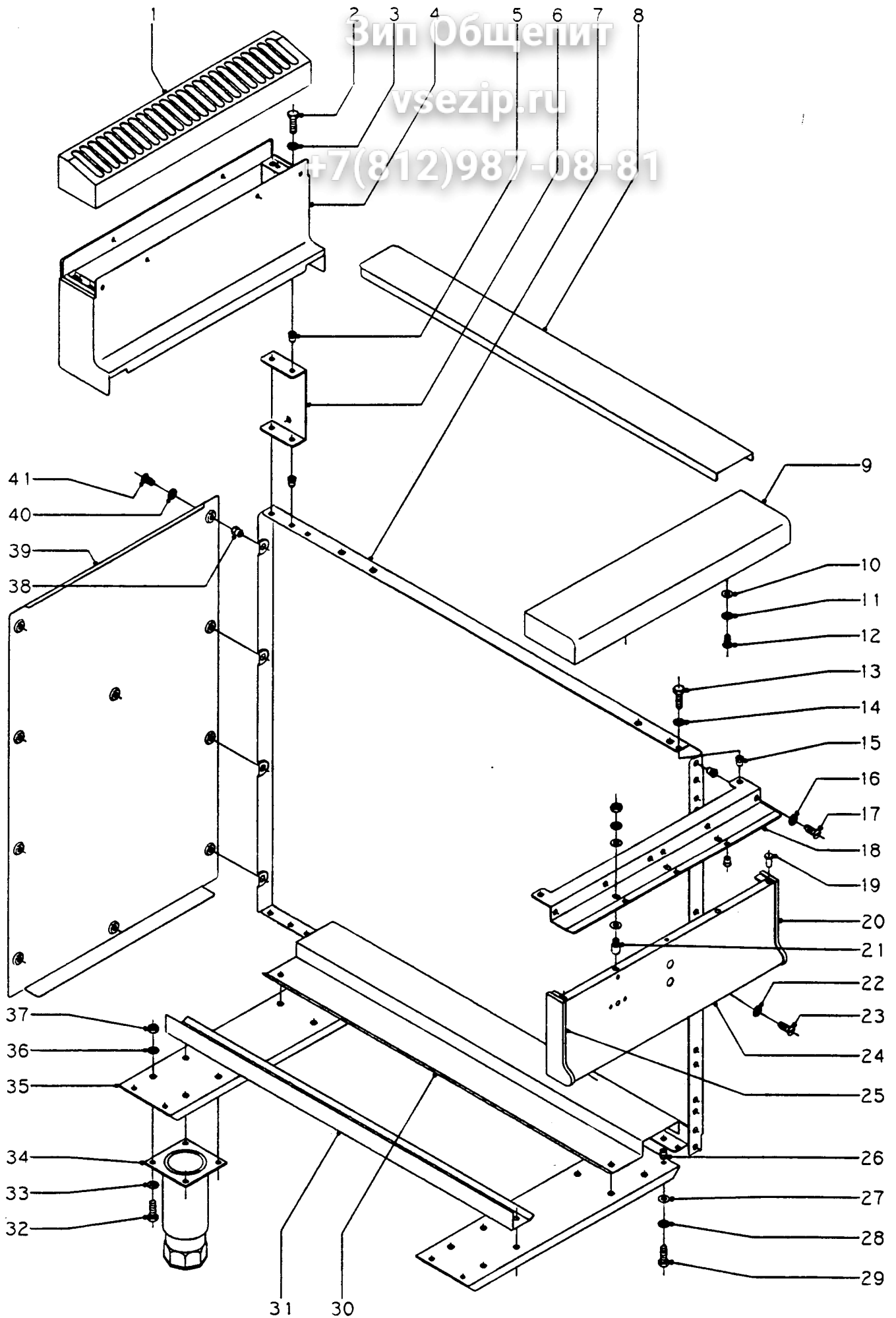
+7(812)987-08-81



N plano C-153	Firma 	Fecha IV-94	Aparato FREIDORAS 900	Lamina 1	Fagor Industrial S.Coop. <b>FAGOR</b>  Onete
------------------	--	----------------	--------------------------	-------------	--

# Зип Ощепит

vsezip.ru

+7(812)987-08-81

**CONCEPTO:** MUEBLE EXTERIOR  
**SUJET:** MEUBLE EXTERIEUR  
**CONCEPT:** EXTERNAL CABINET

**LAMINAN°**  
**VUE N°**  
**ILUSTR. N.**

1

**APARATO - APPAREIL - APPLIANCE:** FREIDORAS - FRITEUSES - FRYERS

**MODELO Y CANTIDAD - MOD. I**

N°	CODIGO	DENOMINACION	DENOMINATION	DESCRIPTION	FG-920	FG-940	FE-920
1	R205410	Embellecedor de chimenea	Enjoliveur de cheminée	Chimney	1	1	-
1	X185401	Embellecedor de chimenea	Enjoliveur de cheminée	Chimney	-	-	1
2	Q011431	Tornillo exagonal M.5x10	Vis M.5x10	Bolt M.5x10	8	8	8
3	Q242030	Arandela abanico A.5	Rondelle A.5	Washer A.5	8	8	8
4	R215402	Posterior de mesa 1/2 M.	Posterieur de table 1/2 M.	Front chimney panel	1	-	1
4	R205403	Posterior de mesa 1 M.	Posterieur de table 1 M.	Front chimney panel	-	1	-
5	Q221342	Remache exagonal M.5	Rivet M.5	Rivet M.5	8	8	8
6	R205409	Escuadra	Equerre	Bracket	2	4	2
7	R202800	Panel lateral	Panneau lateral	Side panel	2	4	2
8	X175400	"U" unión de módulos	"U" union de modules	Modular union "U"	-	1	-
9	R215401	Anterior de mesa 1/2 M.	Anterieur de table 1/2 M.	Front table panel 1/2 M	1	-	1
9	R205401	Anterior de mesa 1 M.	Anterieur de table 1 M.	Front table panel 1 M	-	1	-
10	Q301309	Arandela plana Ø16xØ6x1,2	Rondelle Ø16xØ6x1,2	Washer Ø16xØ6x1,2	2	2	2
11	Q242030	Arandela abanico A.5	Rondelle A.5	Washer A.5	2	2	2
12	Q152004	Tornillo aplastado M.5x10	Vis M.5x10	Bolt M.5x10	2	2	2
13	Q011431	Tornillo exagonal M.5x10	Vis M.5x10	Bolt M.5x10	4	8	4
14	Q242030	Arandela abanico A.5	Rondelle A.5	Washer A.5	4	8	4
15	Q221342	Remache exagonal M.5	Rivet M.5	Rivet M.5	6	12	6
16	Q242030	Arandela abanico A.5	Rondelle A.5	Washer A.5	2	4	2
17	Q152004	Tornillo aplastado M.5x10	Vis M.5x10	Bolt M.5x10	2	4	2
18	R212600	Escuadra fijación portamandos	Equerre fixation panneau	Control panel square fixation	1	2	1
19	Q419005	Remache tubular Ø4x8	Rivet Ø4x8	Rivet Ø4x8	4	4	4
20	U262809	Cantonera derecha portamandos	Cantonière droite pan.comman.	Control panel curb bar-right	1	1	1
21	Q151336	Tornillo soporte guía portam.	Vis support guide pan.comman.	Guide support bolt	2	2	2
	Q301309	Arandela plana Ø16xØ6x1,2	Rondelle Ø16xØ6x1,2	Washer Ø16xØ6x1,2	4	4	4
	Q242040	Arandela abanico A.6	Rondelle A.6	Washer A.6	2	2	2
	Q161440	Tuerca exagonal M.6	Ecrou M.6	Nut M.6	2	2	2
22	Q242030	Arandela abanico A.5	Rondelle A.5	Washer A.5	2	2	2
23	Q152004	Tornillo aplastado M.5x10	Vis M.5x10	Bolt M.5x10	2	2	2
24	X162800	Panel portamandos	Panneau de commande	Control panel	1	-	1
24	X172800	Panel portamandos	Panneau de commande	Control panel	-	1	-



Зип Общепит

vsezip.ru

+7(812)987-08-81

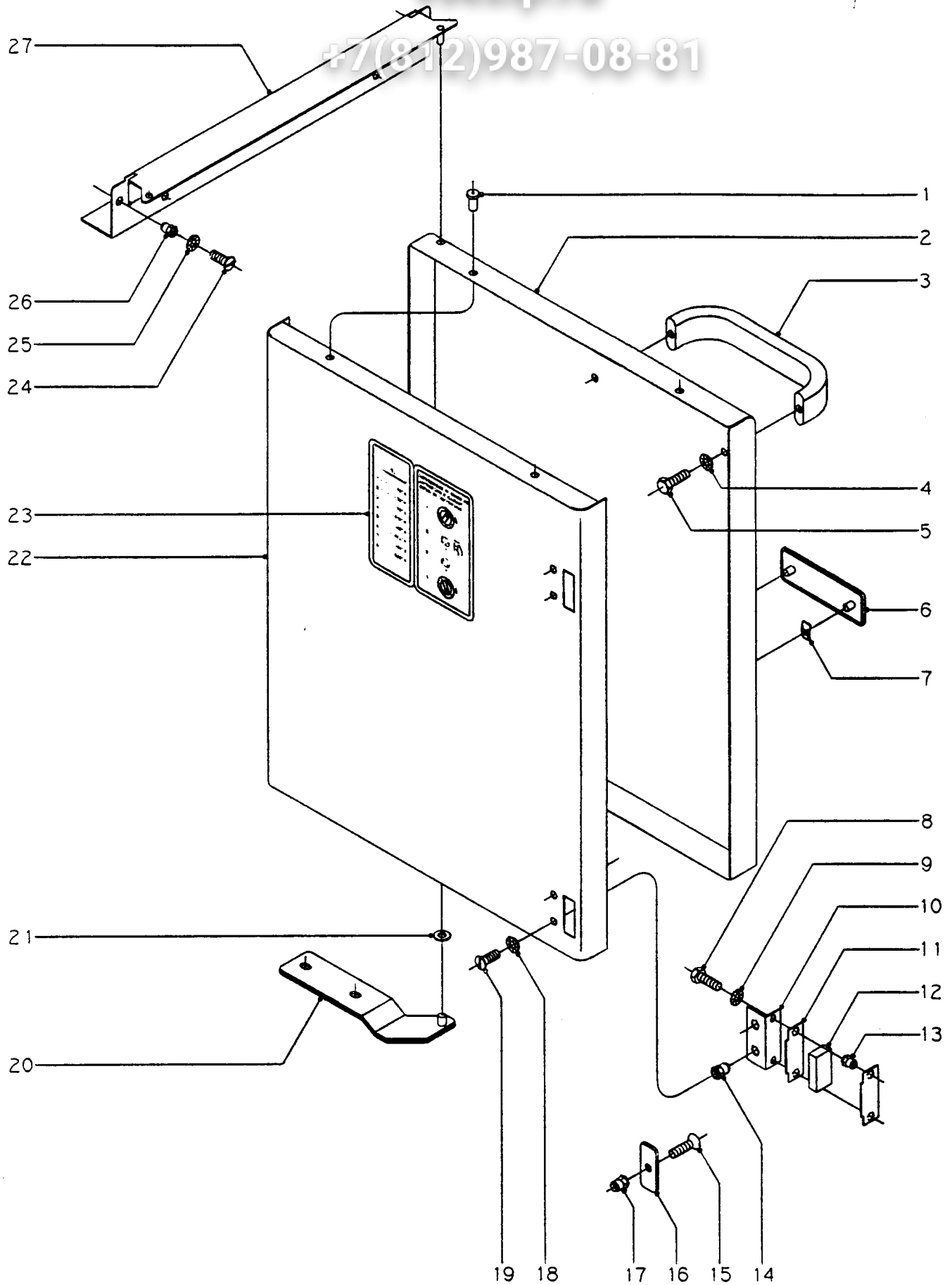

N plano

C-154

Firma



Fecha

IV-94

Aparato

FREIDORAS 900

Lamina

2

Fagor Industrial S.Coop. **FAGOR**

Onate



# Зип Ощепит

vsezip.ru

+7(812)987-08-81

CONCEPTO: PUERTA  
SUJET: PORTE  
CONCEPT: DOOR

LAMINAN°  
VUE N°  
ILUSTR. N.

2

APARATO - APPAREIL - APPLIANCE: FREIDORAS - FRITEUSES - FRYERS

MODELO Y CANTIDAD - MOD. I

N°	CODIGO	DENOMINACION	DENOMINATION	DESCRIPTION	FG-920	FG-940	FE-920
1	Q419005	Remache tubular Ø4x8	Rivet Ø4x8	Rivet Ø4x8	4	8	4
2	X160503	Puerta derecha	Porte droite	Right-hand door	1	1	1
s/n	X170500	Puerta izquierda	Porte gauche	Left-hand door	-	1	-
3	U580521	Asa puerta	Poignée de porte	Door handle	1	2	1
4	Q242040	Arandela abanico A.6	Rondelle A.6	Washer A.6	2	4	2
5	Q011341	Tornillo exagonal M.6x10	Vis M.6x10	Bolt M.6x10	2	4	2
6	U202899	Escudo FAGOR	Emblème FAGOR	FAGOR badge	1	1	1
7	Q221023	Clip sujeción escudo	Clip de fixation	Fixation clip	2	2	2
8	Q013023	Tornillo exagonal M.4x20	Vis M.4x20	Bolt M.4x20	4	8	4
9	Q242020	Arandela abanico A.4	Rondelle A.4	Washer A.4	4	8	4
10	X160508	Escuadra soporte imán	Equerre support aimant	"L" square	2	4	2
11	X160509	Chapa polar de imán	Plaque interieure pour aimant	Interior sheet	4	8	4
12	X160510	Imán	Aimant	Magnet	2	4	2
13	Q221341	Remache exagonal M.4	Rivet M.4	Rivet M.4	4	8	4
14	Q221342	Remache exagonal M.5	Rivet M.5	Rivet M.5	4	8	4
15	Q042032	Tornillo avellanado M.5x15	Vis M.5x15	Bolt M.5x15	2	4	2
16	X160511	Placa de imán	Plaque d'aimant	Steel sheet	2	4	2
17	Q221342	Remache exagonal M.5	Rivet M.5	Rivet M.5	2	4	2
18	Q242030	Arandela abanico A.5	Rondelle A.5	Washer A.5	4	8	4
19	Q152004	Tornillo aplastado M.5x10	Vis M.5x10	Bolt M.5x10	4	8	4
20	X160500	Bisagra inferior derecha	Charnière inferieure droite	Right hinge	1	1	1
s/n	X170501	Bisagra inferior izquierda	Charnière inferieure gauche	Left hinge	-	1	-
21	Q232040	Arandela plana A.6	Rondelle A.6	Washer A.6	1	2	1
22	X160504	Contrapuerta	Contre-porte	Rear door	1	2	1
23	X166511	Tabla temperaturas - instrucc.	Tableau d'instructions	Temperature table	1	1	1
24	Q152004	Tornillo aplastado M.5x10	Vis M.5x10	Bolt M.5x10	6	12	6
25	Q242030	Arandela abanico A.5	Rondelle A.5	Washer A.5	6	12	6
26	Q221342	Remache exagonal M.5	Rivet M.5	Rivet M.5	6	12	6
27	X162612	Listón bisagra superior dcha.	Listel de charnière sup.droite	Hinge right support	1	1	1
s/n	X172600	Listón bisagra superior izda.	Listel de charnière sup.gauche	Hinge left support	-	1	-

Зип Общепит

vsezip.ru

+7(812)987-08-81

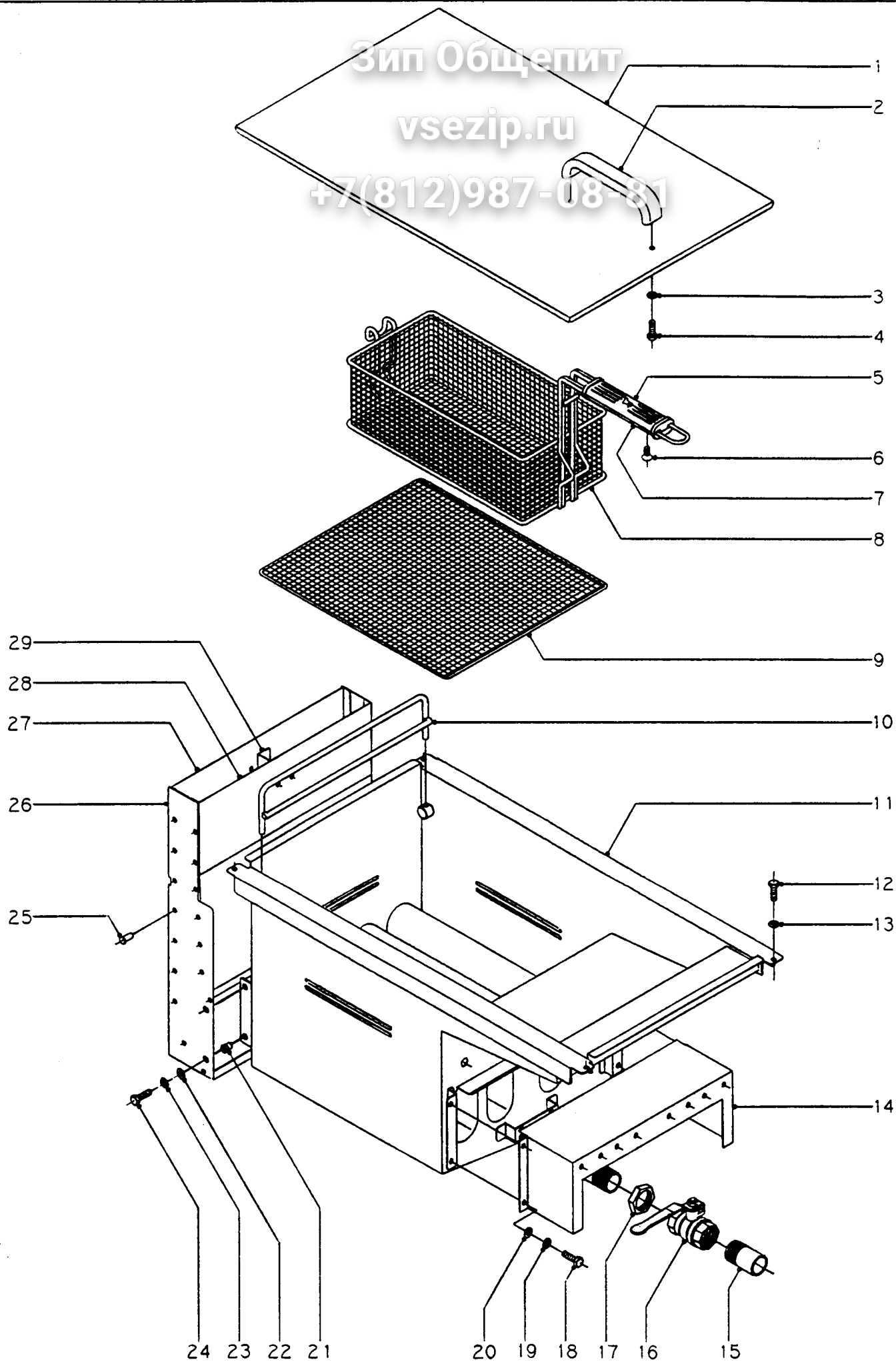

N plano C-155	Firma 	Fecha IV-94	Aparato FREIDORAS 900	Lamina 3	Fagor Industrial S.Coop. <b>FAGOR</b> Orate
------------------	-----------	----------------	--------------------------	-------------	--

# Зип Ощепит

vsezip.ru

+7(812)987-08-81

CONCEPTO: CUBA  
SUJET: CUVE  
CONCEPT: PAN

LAMINAN°  
VUE N°  
ILUSTR. N.

3

APARATO - APPAREIL - APPLIANCE: FREIDORAS - FRITEUSES - FRYERS

MODELO Y CANTIDAD - MOD. I

N°	CODIGO	DENOMINACION	DENOMINATION	DESCRIPTION	FG-920	FG-940	FE-920
1	X166107	Tapa de cuba	Couvercle de cuve	Lid	1	2	-
	X186105	Tapa de cuba	Couvercle de cuve	Lid	-	-	1
2	Z580521	Asa tapa	Poignée	Handle	1	1	1
3	Q242040	Arandela abanico A.6	Rondelle A.6	Washer A.6	2	2	2
4	Q011341	Tornillo exagonal M.6x10	Vis M.6x10	Bolt M.6x10	2	2	2
5	9616402	Cacha superior	Protection sup. de poignée	Top handle	2	4	2
6	Q041431	Tornillo avellanado M.5x10	Vis M.5x10	Bolt M.5x10	4	8	4
7	9616401	Cacha inferior	Protection inf. de poignée	Botton handle	2	4	2
8	X066590	Cestillo pequeño	Panier petit	Small basket	2	4	2
	X066595	Cestillo grande	Panier grand	Large basket	1	2	1
9	X166503	Rejilla	Grille	Grid	1	2	1
10	X166500	Soporte cestillo	Support du panier	Basket support	1	2	1
11	X166100	Cuba completa	Cuve complète	Fryer pan	1	2	-
	X186100	Cuba completa	Cuve complète	Fryer pan	-	-	1
12	Q011431	Tornillo exagonal M.5x10	Vis M.5x10	Bolt M.5x10	4	8	4
13	Q242030	Arandela abanico A.5	Rondelle A.5	Washer A.5	4	8	4
14	X162607	Caja amarre quemadores	Protection brûleurs	Burners protection	1	2	-
15	X396105	Tubo de evacuación	Tube d'evacuation	Drain pipe	1	2	1
16	X036107	Grifo de evacuación	Robinet d'evacuation	Drainage cock	1	2	1
17	Q223014	Contratuercas 1"	Contre-ecrou 1"	Lock-nut 1"	1	2	1
18	Q011431	Tornillo exagonal M.5x10	Vis M.5x10	Bolt M.5x10	4	8	-
19	Q242030	Arandela abanico A.5	Rondelle A.5	Washer A.5	4	8	-
20	Q231330	Arandela plana A.5	Rondelle A.5	Washer A.5	4	8	-
21	Q221343	Remache exagonal M.6	Rivet M.6	Rivet M.6	4	8	-
22	Q232040	Arandela plana A.6	Rondelle A.6	Washer A.6	4	8	-
23	Q242040	Arandela abanico A.6	Rondelle A.6	Washer A.6	4	8	-
24	Q011341	Tornillo exagonal M.6x10	Vis M.6x10	Bolt M.6x10	4	8	-
25	Q419005	Remache tubular Ø4x8	Rivet Ø4x8	Rivet Ø4x8	34	68	-
26	X162603	Lateral de chimenea	Lateral de cheminée	Lateral chimney	2	4	-
27	X162601	Posterior de chimenea	Panneau arrière sortie vapeur	Shaft rear panel	1	2	-
28	X162602	Anterior de chimenea	Panneau avant sortie vapeur	Shaft front panel	1	2	-





Зип-Общепит  
vsezip.ru

+7(812)987-08-81

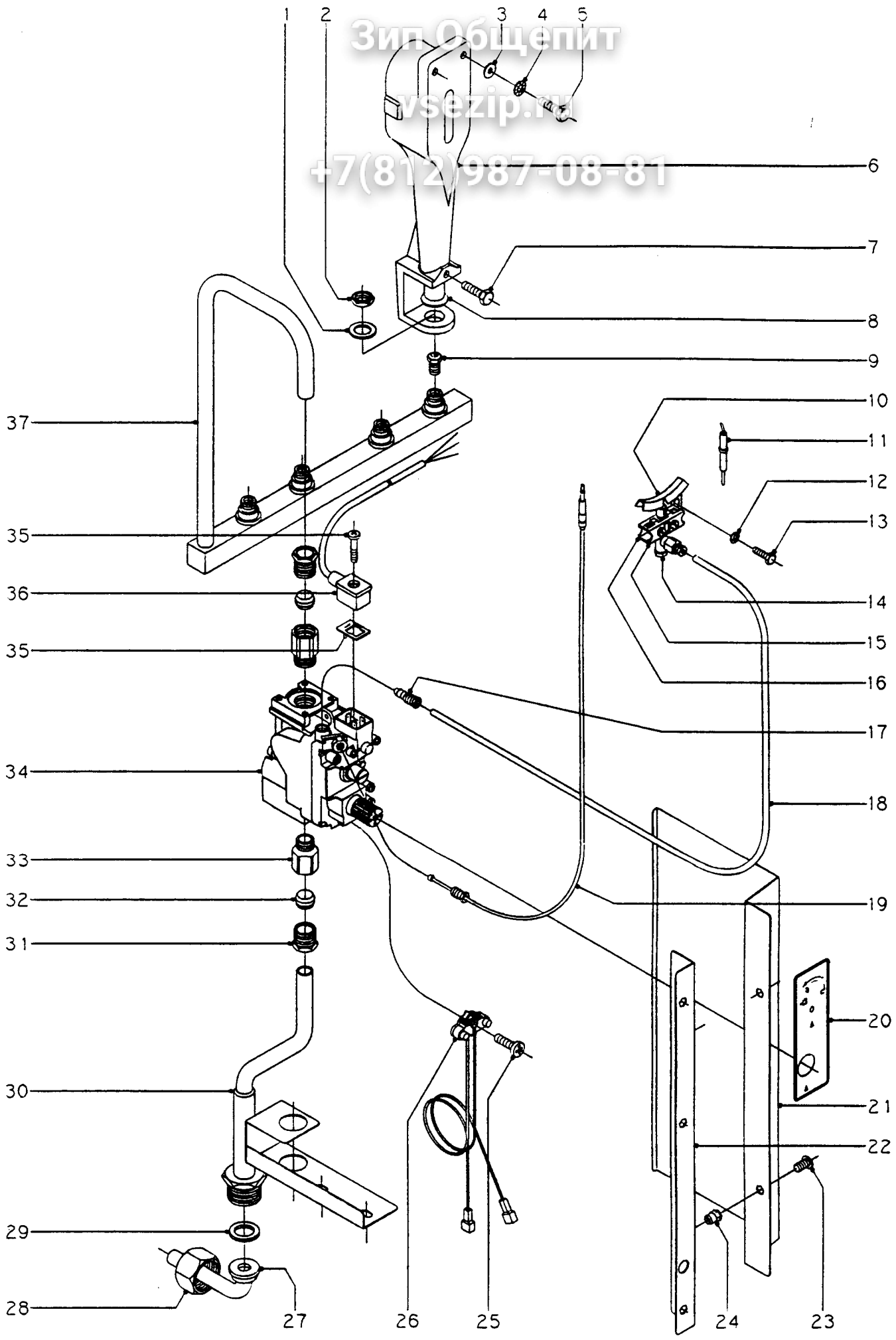

N piano	Firma	Fecha	Aparato	Lamina	Fagor Industrial S. Coop. <b>FAGOR</b>
C-156		IV-94	FREIDORAS 900	4	Orate

# Зип Общепит

vsezip.ru

+7(812)987-08-81

**CONCEPTO:** PARTE FUNCIONAL - GAS  
**SUJET:** PARTIE FONCTIONNELLE - GAZ  
**CONCEPT:** FUNCTIONAL PARTS - GAS

**LAMINAN°**  
**VUE N°**  
**ILUSTR. N.**

4

**APARATO-APPAREIL-APPLIANCE:** FREIDORAS - FRITEUSES - FRYERS

**MODELO Y CANTIDAD - MOD. I**

N°	CODIGO	DENOMINACION	DENOMINATION	DESCRIPTION	FG-920	FG-940	FE-920
1	Q301322	Arandela plana Ø27xØ17x2	Rondelle Ø27xØ17x2	Washer Ø27xØ17x2	4	8	
2	Q223021	Tuerca exagonal M.15x1	Ecrou M.15x1	Nut M.5x1	4	8	
3	Q301309	Arandela plana Ø16xØ6x1,2	Rondelle Ø16xØ6x1,2	Washer Ø16xØ6x1,2	8	16	
4	Q242040	Arandela abanico A.6	Rondelle A.6	Washer A.6	8	16	
5	Q012042	Tornillo exagonal M.6x15	Vis M.6x15	Bolt M.6x15	8	16	
6	X015700	Quemador completo	Brûleur complet	Complete burner	4	8	
7	Q011431	Tornillo exagonal M.5x10	Vis M.5x10	Bolt M.5x10	4	8	
8	X015705	Venturi (B.P. y Gas Natural)	Venturi (B.P. et Gaz Naturel)	Venturi (B.P. - Natural Gas)	4	8	
8	X014300	Venturi (Gas Villa)	Venturi (Gaz Ville)	Venturi (Town Gas)	4	8	
9	X162400	Tobera Ø 1,35 (B.P.)	Injecteur Ø 1,35 (B.P.)	Nozzle Ø 1,35 (B.P.)	4	8	
9	9429500	Tobera Ø 1,90 (Gas Natural)	Injecteur Ø 1,90 (Gaz Naturel)	Nozzle Ø 1,90 (Natural Gas)	4	8	
9	R642400	Tobera Ø 3,70 (Gas Villa)	Injecteur Ø 3,70 (Gaz Ville)	Nozzle Ø 3,70 (Town Gas)	4	8	
10	X012117	Piloto dos direcciones	Veilleuse à deux directions	Two direction pilot	1	2	
s/n	X012122	Regulador de aire piloto	Regulateur d'air veilleuse	Pilot air regulator	1	2	
11	X012101	Bujía	Bougie	Spark plug	1	2	
12	Q242030	Arandela abanico A.5	Rondelle A.5	Washer A.5	2	4	
13	Q011431	Tornillo exagonal M.5x10	Vis M.5x10	Bolt M.5x10	2	4	
14	X012126	Cuerpo piloto c/racord	Corp de veilleuse-racord	Body of pilot with coupling	1	2	
15	X012114	Amarre delantero piloto	Fixation veilleuse (avant)	Front pilot-fastening	1	2	
16	X012113	Amarre trasero piloto	Fixation veilleuse (arrière)	Rear pilot fastening	1	2	
s/n	X012116	Tornillo amarre piloto	Vis d'attachement	Bolt	2	4	
17	U134323	Racord c/bicono Ø6	Raccord avec bicône	Coupling with double cone	1	2	
18	X165006	Tubo piloto	Tube à veilleuse	Pilot tube	1	2	
19	X152120	Termopar L=700	Thermo-couple L=700	Thermocouple L=700	1	2	
20	X162617	Pegatina de posiciones	Adhesif de positions	Instruction label	1	2	
21	X162616	Chapa protección electroválv.	Plaque de protection	Valve protection sheet	1	2	
22	X162620	Amarre protección electroválv.	Fixation de soupape	Valve protection fixed	1	2	
23	Q152004	Tornillo aplastado M.5x10	Vis M.5x10	Bolt M.5x10	2	4	
24	Q221342	Remache exagonal M.5	Rivet M.5	Rivet M.5	2	4	
25	U134321	Tornillo alomado M.4x15	Vis M.4x15	Bolt M.4x15	1	2	
26	R275027	Cableado electrosit	Cablage electrosit	Electrosit wire	1	2	



Сит Общени

vsezip.ru

+7(812)987-08-81

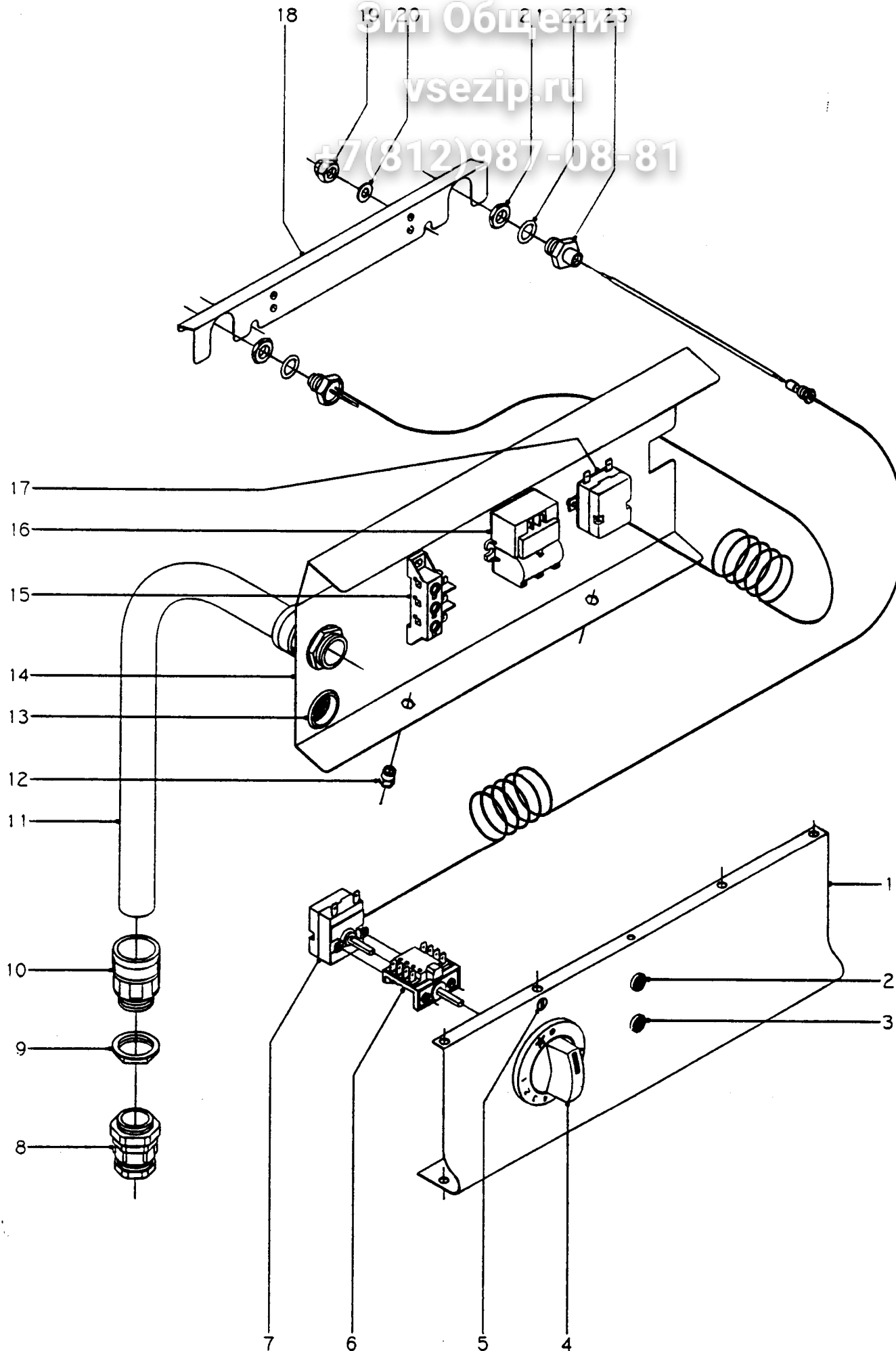

N plano C-157	Firma 	Fecha IV-94	Aparato FREIDORAS 900	Laminas 5	Fabor Industrial S.Coop. <b>FABOR</b> Oferta
------------------	-----------	----------------	--------------------------	--------------	---



Зипъ Общепит

vsezip.ru

+7(812)987-08-81

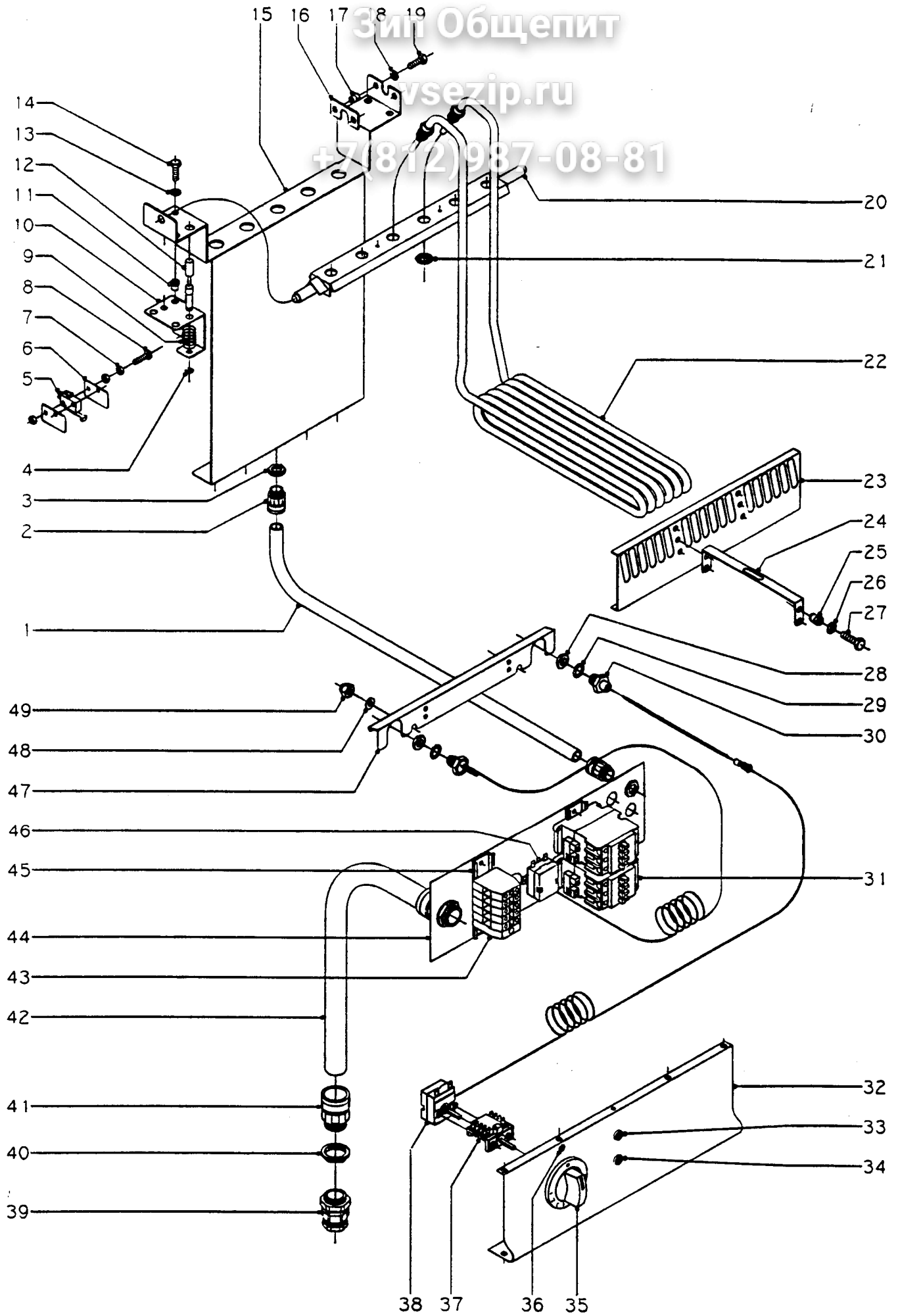

N plano C-158	Firma 	Fecha IV-94	Aparato FREIDORAS 900	Lamina 6	Fabrica Industrial S. Coop. <b>FAOR</b> Orate
------------------	-----------	----------------	--------------------------	-------------	--

# Зип Общепит

vsezip.ru

+7(812)987-08-81

**CONCEPTO:** PARTE FUNCIONAL ELECTRICA  
**SUJET:** PARTIE FONCTIONNELLE ELECTRIQUE  
**CONCEPT:** ELECTRIC PARTS

**LAMINAN°**  
**VUE N°**  
**ILUSTR. N.**

6

**APARATO - APPAREIL - APPLIANCE:** FREIDORAS - FRITEUSES - FRYERS

**MODELO Y CANTIDAD - MOD. I**

N°	CODIGO	DENOMINACION	DENOMINATION	DESCRIPTION	FG-920	FG-940	FE-920
1	X183013	Protección cableado	Protecteur du câblage	Flexible protection			4
2	X033027	Racord SEND-P112T	Raccord SEND-P112T	Racord SEND-P112T			4
3	X033028	Tuerca PG-11	Ecrou PG-11	Nut PG-11			4
4	Q301033	Arandela de seguridad A.6	Rondelle de securité A.6	Washer A.6			1
5	R010534	Micro de elevacion	Micro sécurité résistances	Switch			1
6	R010535	Placa separadora	Plaque à séparation	Separation sheet			2
7	Q161310	Tuerca exagonal M.3	Ecrou M.3	Nut M.3			6
8	Q033113	Tornillo alomado M.3x20	Vis M.3x20	Bolt M.3x20			2
9	R010511	Muelle	Ressort	Spring			1
10	X182606	Escuadra amarre micro	Equerre fixation micro	"L" square			1
11	Q221342	Remache exagonal M.5	Rivet M.5	Rivet M.5			2
12	R010533	Eje micro	Axe du micro	Switch shaft			1
13	Q242030	Arandela abanico A.5	Rondelle A.5	Washer A.5			2
14	Q011431	Tornillo exagonal M.5x10	Vis M.5x10	Bolt M.5x10			2
15	X182604	Soporte de giro	Plaque support	Rotating support			1
16	X182608	Fijación giro resistencias	Fixation pour le tour	Elements revolving fixation			1
17	Q221342	Remache exagonal M.5	Rivet M.5	Rivet M.5			2
18	Q242030	Arandela abanico A.5	Rondelle A.5	Washer A.5			2
19	Q011431	Tornillo exagonal M.5x10	Vis M.5x10	Bolt M.5x10			2
20	X182603	Giro resistencias	Axe du tour de résistances	Elements revolving			1
21		Tuerca (con resistencias)	Ecrou (avec résistances)	Nut (with heater element)			2
22	X183000	Resistencia 6 kW. (230 V.)	Résistance 6 kW. (230 V.)	Heater 6 kW. (230 V.)			3
23	X053001	Escuadra fijación resistencias	Equerre fixation resistances	Fixing element square			2
24	X053013	Escuadra distanciadora	Equerre separation	Square pitch			2
25	Q221342	Remache exagonal M.5	Rivet M.5	Rivet M.5			4
26	Q242030	Arandela abanico A.5	Rondelle A.5	Washer A.5			4
27	Q011431	Tornillo exagonal M.5x10	Vis M.5x10	Bolt M.5x10			4
28	X163012	Tuerca exagonal M.14x1	Ecrou M.14x1	Nut M.14x1			2
29	X012127	Junta tórica Ø20xØ14x3	Joint torique	O-ring			2
30	X166113	Manguito amarre bulbo	Manchon de fixation du bulbe	Tube fixation			1
31	X183011	Contactador 230 V. (50/60 Hz.)	Contacteur 230 V. (50/60 Hz.)	Contactador 230 V. (50/60 Hz.)			2







