

Зип Общепит

vsezip.ru

DESPIECE TECNICO

+7(812)987-08-81

**Sarten basculante eléctrica
Electric tilting Bratt Pan
Sauteuse basculante électriques
Elektro-kippbratpfannen
Brasiere electriche
Fritadeira baculante Elétrica**

GAMA 900

Modelos:

SBE9-10

SBE9-10 I

SBE9-10 M

SBE9-10 I M

SBE9-15 I M

Marzo 2009 March

Revisado Marzo 2014 March Revised



F A G O R I N D U S T R I A L

Зип Общепит

vsezip.ru

+7(812)987-08-81

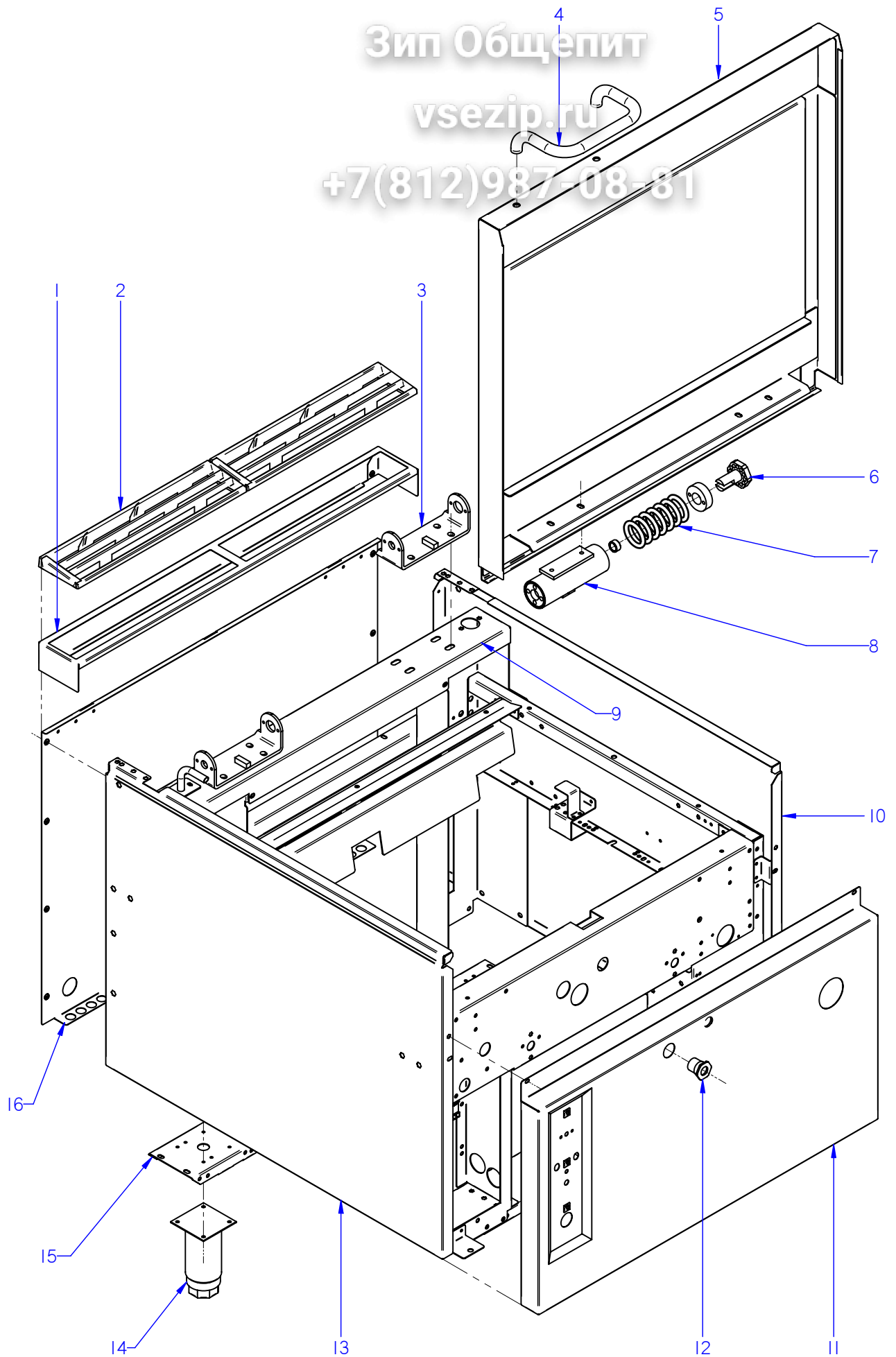

ITEM MARCADO EN COLOR = REPUESTO RECOMENDADO
COLOURED ITEM = RECOMMENDED SPARE PART

N plano	Firma	Fecha	Aparato	MUEBLE	Lamina	Fagor Industrial S.Coop. FAGOR
C-2180	<i>(Signature)</i>	2009-03	SARTEN BASCULANTE G-900		1	Oñate

MOD.		SARTEN BASCULANTE		ZONA		MUEBLE			
ITEM	CODIGO	DENOMINACION	TEXTO	SBE9-10 M	SBE9-10 S	SBE9-10 MS	SBE9-15 M	SBE9-15 MS	
1	R205439000	SOPORTE EMBELLECEDOR 1M	TRIM SUPPORT 1M	1	1				
1	R205440000	SOPORTE EMBELLECEDOR 1,5M	1.5 M TRIM SUPPORT				1	1	
	Q419005000	REMACHE 4x8 ALMG3 / ALUMINIO	RIVET 4X8 ALMG3 / ALUMINIUM	2	2		2	2	
2	R205425000	EMBELLECEDOR ESMALTE	ENAMEL TRIM	2	2		3	3	
3	X286102000	SOPORTE BISAGRA COMPLETA	COMPLETE HINGE SUPPORT	2	2		2	2	
3	X086106000	SOPORTE BISAGRA COMPLETA	COMPLETE HINGE SUPPORT	2	2		2	2	
	Q012053000	TORNILLO EXAGONAL M8x20 A304	HEXAGONAL BOLT M8x20 A304	8	8		8	8	
	Q262050000	ARANDELA GROW. A8 A304	WASHER GROW. A8 A304	8	8		8	8	
	Q232050000	ARANDELA A8	WASHER A8	8	8		8	8	
	Q162050000	TUERCA EXAGONAL M8x1 INOX.	HEXAGONAL NUT M8x1 INOX.	8	8		8	8	
4	S036123000	ASA DE TAPA	COVER HANDLE	1	1		1	1	
	X152809000	TORNILLO SUJEC. ASA DE TAPA	LID HANDLE FASTENING BOLT	2	2		2	2	
	Q302027000	ARANDELA 25x6x8,4x2	WASHER 25X6X8.4X2	2	2		2	2	
5	X022825000	TAPA COMPLETA GAMA 900 1M	LID COMPLETE RANGE 900 1M	1	1				
5	12098814	TAPA COMPLETA GAMA 900 1M	LID COMPLETE RANGE 900 1M	1	1				
5	X082813000	TAPA COMPLETA GAMA 900 1,5M	LID COMPLETE RANGE 900 1.5M				1	1	
5	12098812	TAPA COMPLETA GAMA 900 1,5M	LID COMPLETE RANGE 900 1.5M				1	1	
	Q012051000	TORNILLO EXAGONAL M8x10	HEXAGONAL BOLT M8x10	4	4		4	4	
6	S116120000	TENSOR MUELLE	TENSIONING SPRING	2	2		2	2	
	Q012042000	TORNILLO EXAGONAL M6x15	HEXAGONAL BOLT M6x15	4	4		4	4	
	Q262040000	ARANDELA GROW. A6 A304	WASHER GROW. A6 A304	4	4		4	4	
	S116118000	CASQUILLO	BUSHING	2	2		2	2	
7	S116121000	RESORTE TAPA 07199	SPRING COVER 07199	2	2		2	2	
8	X156101000	BISAGRA COMPLETA	COMPLETE HINGE	2	2		2	2	
	S116126000	COJINETE CILINDRICO	CYLINDRICAL BEARING	2	2		2	2	
	S116119000	GIRO DE ASA	HANDLE ROTATION	2	2		2	2	
	Q012041000	TORNILLO EXAGONAL M6x10 A304	HEXAGONAL BOLT M6x10 A304	4	4		4	4	
9	X020108000	CUBIERTA PUENTE	BRIDGE COVERING	1	1				
9	X080103000	CUBIERTA PUENTE G.900 1.5M	BRIDGE COVERING G.900 1.5M				1	1	
	Q411302000	REMACHE MONOBOLT Ø6.35	MONOBOLT RIVET D6.35	6	6		6	6	
	Q221342000	REMACHE EXAGONAL M5	HEXAGONAL RIVET M5	2	2		2	2	

MOD.		SARTEN BASCULANTE		ZONA vsezip.ru		MUEBLE			
ITEM	CODIGO	DENOMINACION	TEXTO	SBE9-10	SBE9-10 M	SBE9-10 S	SBE9-10 MS	SBE9-15 M	SBE9-15 MS
10	X042804000	PANEL LATERAL DERECHO	RIGHT SIDE PANEL	1	-	-	-	1	-
10	X022818000	PANEL LATERAL DERECHO SUSP.	SUSP. RIGHT SIDE PANEL	-	-	1	-	-	1
	Q221343000	REMACHE EXAGONAL M6	HEXAGONAL RIVET M6	11	-	-	-	11	-
	Q012042000	TORNILLO EXAGONAL M6x15	HEXAGONAL BOLT M6x15	4	-	-	-	4	-
	Q262040000	ARANDELA GROW. A6 A304	WASHER GROW. A6 A304	4	-	-	-	4	-
	Q221342000	REMACHE EXAGONAL M5	HEXAGONAL RIVET M5	3	-	3	-	3	3
	Q152004000	TORNILLO APLASTADO M5x13	FLAT HEAD SCREW M5X13	1	-	1	-	1	1
	Q162030000	TUERCA EXAGONAL M5	HEXAGONAL NUT M5	-	-	1	-	-	1
11	X022829000	PANEL FRONTAL SBG9-10	FRONT PANEL SBG9-10	-	-	-	-	-	-
11	X022830000	PANEL FRONTAL SBG9-10 M	FRONT PANEL SBG9-10 M	-	-	-	-	-	-
11	X042810000	PANEL FRONTAL SBE9-10	FRONT PANEL SBE9-10	1	-	1	-	-	-
11	X042809000	PANEL FRONTAL SBE9-10 M	FRONT PANEL SBE9-10 M	1	-	1	-	-	-
11	X082814000	PANEL FRONTAL SBG9-15	FRONT PANEL SBG9-15	-	-	-	-	-	-
11	X082815000	PANEL FRONTAL SBE9-15	FRONT PANEL SBE9-15	-	-	-	-	1	1
	Q152004000	TORNILLO APLASTADO M5X13	FLAT HEAD SCREW M5X13	2	-	2	-	2	2
	Q012042000	TORNILLO EXAGONAL M6x15	HEXAGONAL BOLT M6x15	2	-	2	-	2	2
	Q262040000	ARANDELA GROW. A6 A304	WASHER GROW. A6 A304	2	-	2	-	2	2
12	S112804000	EMBELLECEDOR TUBO	PIPE TRIM	-	-	-	-	-	-
13	X042803000	PANEL LATERAL IZQUIERDO	LEFT SIDE PANEL	1	-	-	-	1	-
13	X022817000	PANEL LATERAL IZQUIERDO SUSP.	SUSP. LEFT SIDE PANEL	-	-	1	-	-	1
	Q221343000	REMACHE EXAGONAL M6	HEXAGONAL RIVET M6	11	-	-	-	11	-
	Q012042000	TORNILLO EXAGONAL M6x15	HEXAGONAL BOLT M6x15	4	-	-	-	4	-
	Q262040000	ARANDELA GROW. A6 A304	WASHER GROW. A6 A304	4	-	-	-	4	-
	Q221342000	REMACHE EXAGONAL M5	HEXAGONAL RIVET M5	3	-	3	-	3	3
	Q152004000	TORNILLO APLASTADO M5x13	FLAT HEAD SCREW M5X13	1	-	1	-	1	1
	Q162030000	TUERCA EXAGONAL M5	HEXAGONAL NUT M5	-	-	1	-	-	1
14	X260151000	PATA REGULABLE	ADJUSTABLE LEG	4	-	-	-	4	-
	Q411304000	REMACHE AVIBULB Ø 4,8	AVIBULB RIVET Ø 4.8	16	-	-	-	16	-

Зип Общепит

vsezip.ru

+7(812)987-08 81

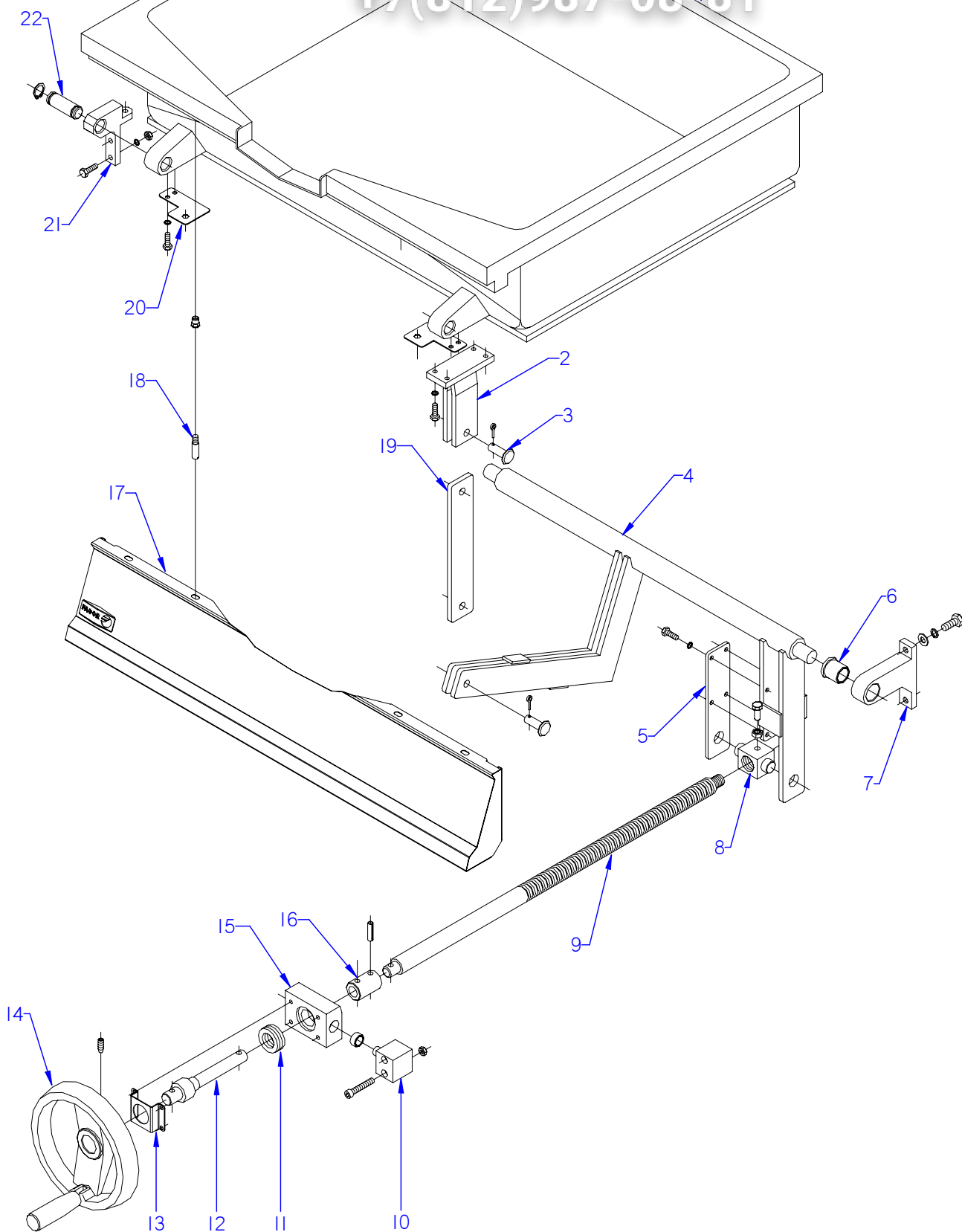

ITEM MARCADO EN COLOR = REPUESTO RECOMENDADO
COLOURED ITEM = RECOMMENDED SPARE PART

N plano	Firma	Fecha	Aparato	CUBA (ELEVACION MANUAL)	Lamina	Fagor Industrial S.Coop. FAGOR
C-2181	<i>[Signature]</i>	2009-03	SARTEN BASCULANTE G 900		2	Oñate

MOD.	SARTEN BASCULANTE	ZONA	CUBA (ELEVACION MANUAL)					
ITEM	CODIGO	DENOMINACION	TEXTO	SBE9-10	SBE9-10 I			
1	X156155000	CUBA FUNDIDA SBG9-10	CAST IRON TUB SBG9-10	1	—			
1	X146125000	CUBA FUNDIDA SBG9-10	CAST IRON TUB SBG9-10	1	—			
1	12007698	CUBA FUNDIDA SBG9-10	CAST IRON TUB SBG9-10	1	—			
1	12009588	CUBA INOXIDABLE SARTEN 910	INOX TUB FRYPAN 910	—	1			
2	X156157000	HORQUILLA DE GIRO	ROTATION FORK	1	—			
	Q012043000	TORNILLO EXAGONAL M6x20 A304	HEXAGONAL BOLT M6x20 A304	4	—			
	Q262040000	ARANDELA GROW. A6 A304	WASHER GROW. A6 A304	4	—			
3	X156123000	BULON Ø12	PIN Ø12	2	2			
	Q352024000	PASADOR DE ALETAS Ø4x25	COTTER PIN Ø4x25	2	2			
4	X156148000	BRAZO ELEVADOR COMPLETO	COMPLETE ELEVATION ARM	1	1			
	Q131555000	VARILLA ROSCADA M8x30	THREADED ROD M8X30	14	14			
	Q131558000	VARILLA ROSCADA M8x60	THREADED ROD M8X60	4	4			
	Q162050000	TUERCA EXAGONAL M8x1	HEXAGONAL NUT M8x1	4	4			
5	X156149000	BRAZO LATERAL	SIDE ARM	1	1			
	Q012042000	TORNILLO EXAGONAL M6x15	HEXAGONAL BOLT M6x15	4	4			
	Q262040000	ARANDELA GROW. A6 A304	WASHER GROW. A6 A304	4	4			
6	X109550000	COJINETE SELFOIL B11	BEARING SELFOIL B11	2	2			
7	X150108000	SOPORTE DE GIRO	ROTATION SUPPORT	2	2			
	Q012063000	TORNILLO EXAG. M10x20 A304	HEX BOLT M10x20 A304	4	4			
	Q261060000	ARANDELA MUELLE A10	SPRING WASHER A10	4	4			
	Q232060000	ARANDELA A10	WASHER A10	4	4			
8	X156154000	TUERCA HUSILLO	SPINDLE NUT	1	1			
8	X146136000	TUERCA HUSILLO	SPINDLE NUT	1	1			
8	12046610	TUERCA HUSILLO	SPINDLE NUT	1	1			
	Q011364000	TORNILLO EXAG. M10x25	HEX BOLT M10x25	1	1			
	Q161360000	TUERCA EXAG. M10 H. ZINCADA	HEXAG. SCREW M10 H. ZINC-CO	1	1			
9	X156152000	HUSILLO GAMA 900	SPINDLE RANGE 900	1	1			
9	X146134000	HUSILLO GAMA 900	SPINDLE RANGE 900	1	1			
9	12046627	HUSILLO GAMA 900	SPINDLE RANGE 900	1	1			

MOD.		SARTEN BASCULANTE		ZONA	CUBA (ELEVACION MANUAL)			
ITEM	CODIGO	DENOMINACION	TEXTO	SBE9-10	SBE9-10 I			
10	X156113000	PIVOTE DE GIRO	ROTATION PIVOT	2	2			
	S116126000	COJINETE CILINDRICO	CYLINDRICAL BEARING	2	2			
	Q052046000	TORNILLO ALLEN M6x40 A304	ALLEN BOLT M6x40 A304	4	4			
	Q162040000	TUERCA EXAGONAL M6	HEXAGONAL NUT M6	4	4			
11	X156125000	RODAMIENTO 51204	BEARING 51204	1	1			
12	X156161000	EJE VOLANTE COMPLETO	COMPLETE FLYSHAFT	1	1			
13	X152619000	SOPORTE EJE VOLANTE	FLYSHAFT SUPPORT	1	1			
	Q012041000	TORNILLO EXAGONAL M6x10 A304	HEXAGONAL BOLT M6x10 A304	4	4			
	Q262040000	ARANDELA GROW. A6 A304	WASHER GROW. A6 A304	4	4			
14	X156139000	VOLANTE ELESA	FLYSHAFT ELESA	1	1			
	Q131552000	VARILLA ROSCADA M8x15	THREADED ROD M8X15	2	2			
15	X156114000	SOPORTE RODAMIENTO	BEARING SUPPORT	1	1			
16	X156115000	CASQUILLO	BUSHING	1	1			
	Q371027000	MANGUITO DE SUJECCION Ø8x30	FASTENING SLEEVE Ø8x30	2	2			
17	X022822000	PORTAMANDOS SARTEN FUN. 1M	C.IRON FRYPAN CONTROL HOLD	1	—			
17	X022824000	PORTAMANDOS SARTEN INOX. 1M	INOX FRYPAN CONTROL HOLDEP	—	1			
	U022836000	ESCUDO FAGOR	FAGOR EMBLEM	1	1			
	Q012042000	TORNILLO EXAGONAL M6x15	HEXAGONAL BOLT M6x15	2	2			
	Q301304000	ARANDELA PLANA 23x6,5x2	FLAT WASHER 23X6.5X2	2	2			
	Q221023000	CLIP SUJECION RÁPIDA D-5	QUICK FASTENING CLIP D-5	2	2			
18	Q151336000	TORNILLO SOPORTE GUIAS	GUIDE SUPPORT BOLT	2	2			
19	X156151000	BRAZO	ARM	1	1			
20	X156156000	AMARRE PANEL PORTAMANDOS	CONTROL HOLDER PANEL FAST.	2	—			
	Q012041000	TORNILLO EXAGONAL M6x10 A304	HEXAGONAL BOLT M6x10 A304	4	—			
	Q262040000	ARANDELA GROW. A6 A304	WASHER GROW. A6 A304	4	—			
21	X156145000	SOPORTE GIRO CUBA	TUB ROTATION SUPPORT	2	2			
	Q012043000	TORNILLO EXAGONAL M6x20 A304	HEXAGONAL BOLT M6x20 A304	6	6			
	Q262040000	ARANDELA GROW. A6 A304	WASHER GROW. A6 A304	6	6			
	Q162040000	TUERCA EXAGONAL M6	HEXAGONAL NUT M6	6	6			
22	X109511000	BULON LATON	BRASS BOLT	2	2			
	Q301020000	ANILLO DE SEGURIDAD 20x1,2	CIRCLIP 20x1.2	4	4			

Зип Общепит

vsezip.ru

+7(812)987-08-81

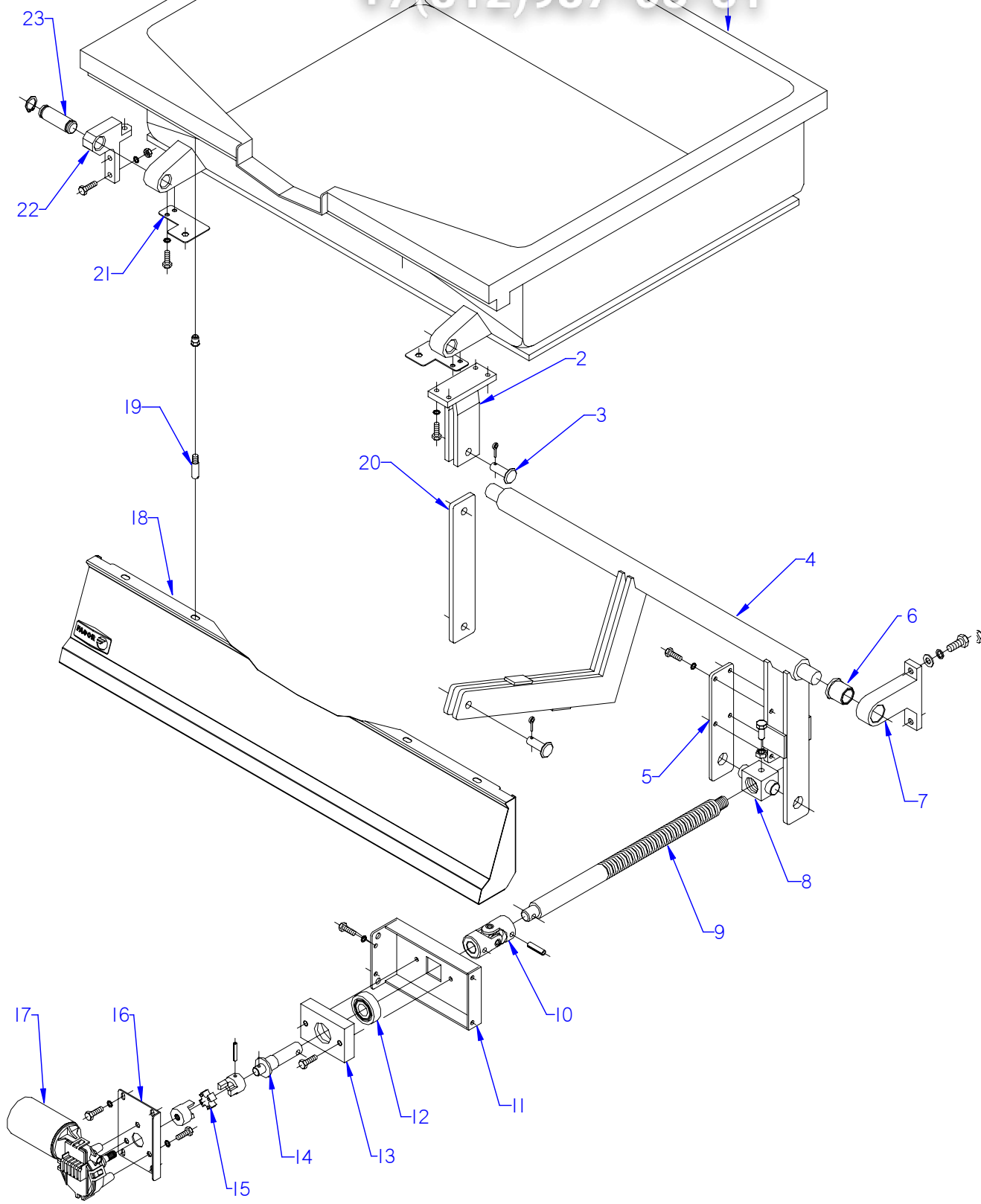

ITEM MARCADO EN COLOR = REPUESTO RECOMENDADO
COLOURED ITEM = RECOMMENDED SPARE PART

N plano	Firma	Fecha	Aparato	CUBA (ELEVACION MOTOR)	Lamina	Fagor Industrial S.Coop. FAGOR
C-2182	<i>(Signature)</i>	2009-03	SARTEN BASCULANTE G 900	3	Oñate	

MOD.		SARTEN BASCULANTE		ZONA	CUBA (ELEVACION MOTOR)		
ITEM	CODIGO	DENOMINACION	TEXTO	SBE9-10 M	SBE9-10 IM	SBE9-15 IM	
1	X156155000	CUBA FUNDIDA SBG9-10	CAST IRON TUB SBG9-10	-	-	-	
1	X146125000	CUBA FUNDIDA SBG9-10	CAST IRON TUB SBG9-10	-	-	-	
1	X146133000	CUBA INOXIDABLE SBG9-10	INOX TUB SBG9-10	-	-	-	
1	X146125000	CUBA FUNDIDA SBE9-10	CAST IRON TUB SBE9-10	1	-	-	
1	X146133000	CUBA INOXIDABLE SBE9-10	INOX TUB SBE9-10	-	1	-	
1	X286111000	CUBA INOXIDABLE SBG9-15	INOX TUB SBG9-15	-	-	-	
1	X426106000	CUBA INOXIDABLE SBE9-15	INOX TUB SBE9-15	-	-	1	
	Q221343000	REMACHE EXAGONAL M6	HEXAGONAL RIVET M6	2	2	2	
	Q221343000	REMACHE EXAGONAL M6	HEXAGONAL RIVET M6	2	2	2	
2	X156157000	HORQUILLA DE GIRO	ROTATION FORK	1	-	-	
	Q012043000	TORNILLO EXAGONAL M6x20 A304	HEXAGONAL BOLT M6x20 A304	4	-	-	
	Q262040000	ARANDELA GROW. A6 A304	WASHER GROW. A6 A304	4	-	-	
3	X156123000	BULON Ø12	PIN Ø12	2	2	2	
	Q352024000	PASADOR DE ALETAS Ø4x25	COTTER PIN Ø4x25	2	2	2	
4	X156148000	BRAZO ELEVADOR COMP.SB9-10	COMP. ELEVATION ARM SB9-10	1	1	-	
4	X286106000	BRAZO ELEVADOR COMP.SBG9-15	COMP. ELEVATION ARM SBG9-15	-	-	-	
4	X426103000	BRAZO ELEVADOR COMP.SBE9-15	COMP. ELEVATION ARM SBE9-15	-	-	1	
5	X156149000	BRAZO LATERAL	SIDE ARM	1	1	1	
	Q012042000	TORNILLO EXAGONAL M6x15	HEXAGONAL BOLT M6x15	4	4	4	
	Q262040000	ARANDELA GROW. A6 A304	WASHER GROW. A6 A304	4	4	4	
6	X109550000	COJINETE SELFOIL B11	BEARING SELFOIL B11	2	2	2	
7	X150108000	SOPORTE DE GIRO	ROTATION SUPPORT	2	2	2	
	Q012063000	TORNILLO EXAG. M10x20 A304	HEX BOLT M10x20 A304	4	4	4	
	Q261060000	ARANDELA MUELLE A10	SPRING WASHER A10	4	4	4	
	Q232060000	ARANDELA A10	WASHER A10	4	4	4	
8	X156154000	TUERCA HUSILLO	SPINDLE NUT	1	1	1	
8	X146136000	TUERCA HUSILLO	SPINDLE NUT	1	1	1	
8	12046610	TUERCA HUSILLO	SPINDLE NUT	1	1	1	
	Q011364000	TORNILLO EXAG. M10x25	HEX BOLT M10x25	1	1	1	
	Q161360000	TUERCA EXAG. M10 H. ZINCADA	HEXAG. SCREW M10 H. ZINC-CO	1	1	1	

MOD.		SARTEN BASCULANTE		ZONA	CUBA (ELEVACION MOTOR)		
ITEM	CODIGO	DENOMINACION	TEXTO	SBE9-10 M	SBE9-10 IM	SBE9-15 IM	
9	X156152000	HUSILLO GAMA 900	SPINDLE RANGE 900	1	1	1	
9	X146134000	HUSILLO GAMA 900	SPINDLE RANGE 900	1	1	1	
9	12046627	HUSILLO GAMA 900	SPINDLE RANGE 900	1	1	1	
10	X126114000	JUNTA UNIVERSAL 107A	UNIVERSAL JOINT 107A	1	1	1	
	Q371027000	MANGUITO DE SUJECCION Ø8x30	FASTENING SLEEVE Ø8x30	2	2	2	
11	X342607000	SOPORTE EJE MOTOR	MOTOR SHAFT SUPPORT	1	1	1	
	Q012032000	TORNILLO EXAGONAL M5x15 A304	HEXAGONAL BOLT M5x15 A304	4	4	4	
	Q262030000	ARANDELA GROW. A5 A304	WASHER GROW. A5 A304	4	4	4	
12	X346109000	RODAMIENTO SKF	SKF BEARING	1	1	1	
13	X346105000	SOPORTE RODAMIENTO	BEARING SUPPORT	1	1	1	
	Q012044000	TORNILLO EXAGONAL M6x25	HEXAGONAL BOLT M6x25	2	2	2	
14	X346106000	EJE MOTOR	MOTOR SHAFT	1	1	1	
15	X346107000	ACOPLAMIE. ELASTICO LOVEJOY	ELASTIC LOVEJOY COUPLING	1	1	1	
	Q371032000	PASADOR ELASTICO Ø5x30	ELASTIC PIN Ø5x30	2	2	2	
16	X342603000	SOPORTE MOTOR	MOTOR SUPPORT	1	1	1	
	Q012042000	TORNILLO EXAGONAL M6x15	HEXAGONAL BOLT M6x15	4	4	4	
	Q262040000	ARANDELA GROW. A6 A304	WASHER GROW. A6 A304	4	4	4	
17	X343020000	MOTORREDUCTOR (BOSCH)	GEAR MOTOR (BOSCH)	1	1	1	
	Q012042000	TORNILLO EXAGONAL M6x15	HEXAGONAL BOLT M6x15	3	3	3	
	Q262040000	ARANDELA GROW. A6 A304	WASHER GROW. A6 A304	3	3	3	
18	X022822000	PORTAMANDOS COMPL. SB9-10	COMPL. CONTROL HOLDER SB9	1			
18	X022824000	PORTAMANDOS COMPL. SB9-10 I	COMPL. CONTROL HOLDER SB9		1		
18	X082812000	PORTAMANDOS COMPL. SB9-15 I	COMPL. CONTROL HOLDER SB9			1	
	U022836000	ESCUDO FAGOR	FAGOR EMBLEM	1	1	1	
	Q301304000	ARANDELA PLANA 23x6,5x2	FLAT WASHER 23X6.5X2	2	2	2	
	Q012042000	TORNILLO EXAGONAL M6x15	HEXAGONAL BOLT M6x15	2	2	2	
	Q221023000	CLIP SUJECIÓN RÁPIDA D-5	QUICK FASTENING CLIP D-5	2	2	2	
19	Q151336000	TORNILLO SOPORTE GUIAS	GUIDE SUPPORT BOLT	2	2	2	
20	X156151000	BRAZO	ARM	1	1	1	

ЗипОбщепит

vsezip.ru

+7(812)987-08-81

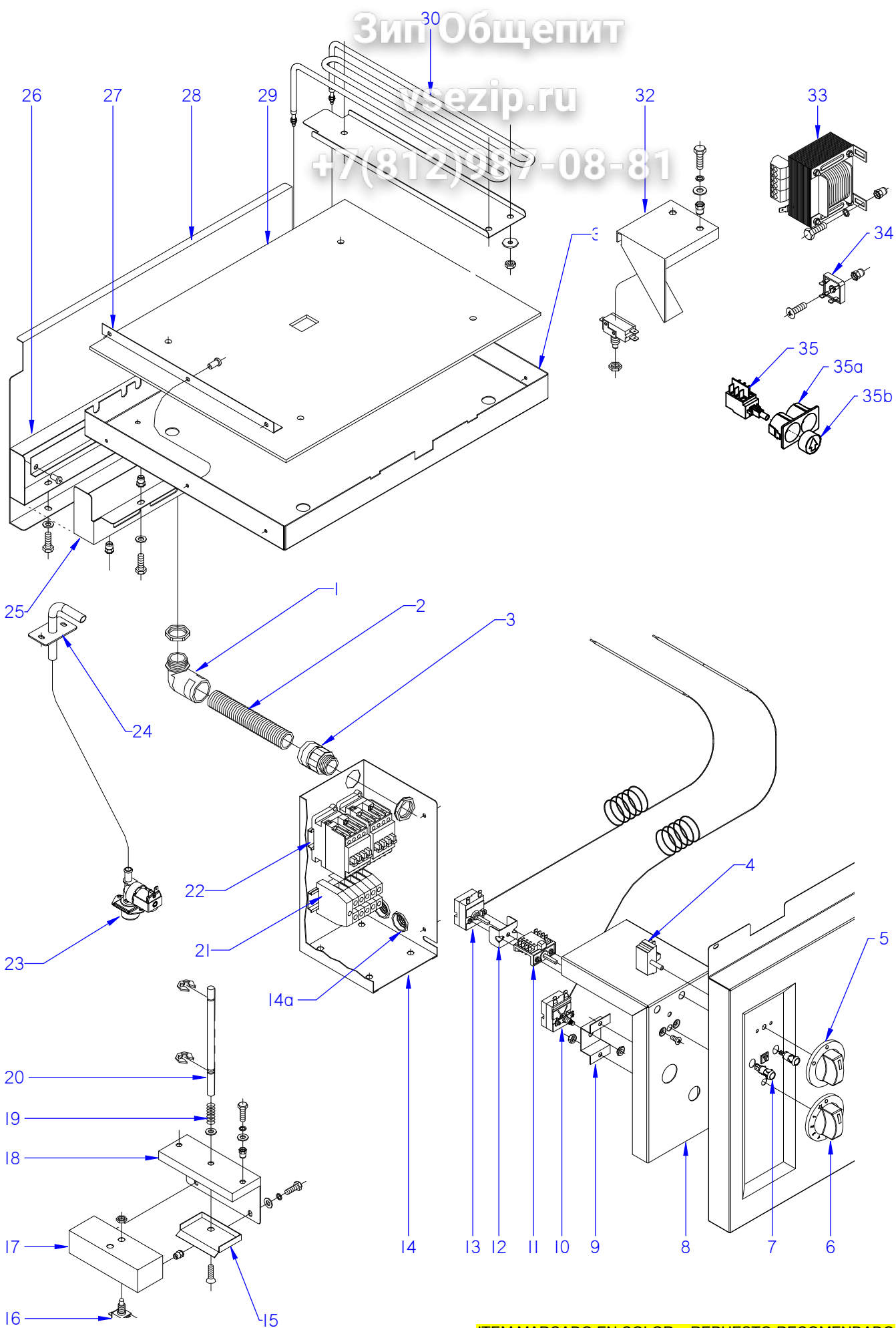

ITEM MARCADO EN COLOR = REPUESTO RECOMENDADO
COLOURED ITEM = RECOMMENDED SPARE PART

N plano	Firma	Fecha	Aparato	CONJUNTO FUNCIONAL ELECTRICO	Lamina	Fagor Industrial S.Coop. FAGOR
C-2185	<i>(Signature)</i>	2009-03	SARTEN BASCULANTE SBE		6	Oñate

Зип Общепит

MOD.	SARTEN BASCULANTE	ЗЧНА	CONJUNTO FUNCIONAL ELECTRICO
-------------	--------------------------	------	-------------------------------------

ITEM	CODIGO	DENOMINACION	TEXTO	SBE9-10	SBE9-10 M	SBE9-10 IM	SBE9-15 IM
1	Z703006000	RACORD A 90 SFWO-P213T	CONNECTION A 90 SFWO-P213T	1	1	1	1
	12010063	CONTRATUERCA GAES	COUNTERNUT GAES	1	1	1	1
2	3712300000	TUBO PG21 0233.204.023	PIPE PG21 0233.204.023	1	1	1	1
3	X713021000	RACORD ICK 5020	CONNECTION ICK 5020	1	1	1	1
	12010063	CONTRATUERCA GAES	COUNTERNUT GAES	1	1	1	1
4	T343008000	CONMUTADOR HGC	HGC SWITCH	1	1	1	1
	Q151320000	TORN. ALOMADO M4X6 H.ZINCADO	HEXAGONAL CURVED HEAD M4X6	2	2	2	2
5	X022133000	BOTON DE MANDO Ø6 (EN. AGUA)	CONTROL BUTTON Ø6 (WATER II	1	1	1	1
6	U173005000	BOTON DE MANDO Ø6	CONTROL BUTTON Ø6	1	1	1	1
7	X143017000	PILOTO VERDE SARTEN	GREEN FRYPAN PILOT	1	1	1	1
	12047390	PILOTO VERDE 230V AC 8KW 16MM	GREEN PILOT 230V AC 8KW 16MM	1	1	1	1
	X143018000	PILOTO AMBAR SARTEN	FRYING PAM AMBER PILOT	1	1	1	1
	12024669	PILOTO AMBAR Ø18	AMBER PILOT Ø18	1	1	1	1
8	X152667000	TAPA CAJA SOPORTE VALVULA	VALVE SUPPORT BOX COVER	1	1	1	1
9	X152661000	SOPORTE LIMITADOR	LIMITER SUPPORT	1	1	1	1
	Q162030000	TUERCA EXAGONAL M5	HEXAGONAL NUT M5	2	2	2	2
10	R612103000	TERMOSTATO LIMITADOR	THERMOSTAT LIMITER	1	1	1	1
	Q013023000	TORNILL. EXAGONAL M4x20 LATON	HEXAGONAL BOLT M4X20 BRASS	1	1	1	1
	Q163020000	TUERCA EXAGONAL M4 LATON	HEXAGONAL NUT M4 BRASS	1	1	1	1
	Q183001000	TUERCA CUADRADA M4	SQUARE NUT M4	1	1	1	1
	Q563004000	LENGÜETA COMPONENT. DOBLE	DOUBLE COMPONENT TONGUE	1	1	1	1
	Z603022000	PLACA ASIENTO CONEXIÓN MASA	SEATING PLATE EARTH CONNEC	1	1	1	1
11	X163007000	CONMUTADOR ACOPLE TERMOS	THERMOSTAT CONNECT SWITCH	1	1	1	1
12	X313001000	"U" SOPORTE TERMOSTATO	THERMOSTAT U SUPPORT	1	1	1	1
13	X153000000	TERMOSTATO 50-310 C	THERMOSTAT 50-310 C	1	1	1	1
	Q042021000	TORNIL. AVELLANADO M4x10 A304	COUNTERSUNK BOLT M4X10 A304	2	2	2	2
14	X152656000	SOPORTE VALVULA	VALVE SUPPORT	1	1	1	1
14a	12009973	CONTRATUERCA GAES	COUNTERNUT GAES	1	1	1	1
	X723014000	PASAMUROS Ø 30	WALL BUSHING Ø 30	3	3	3	3
	Q411304000	REMACHE AVIBULB Ø 4,8	AVIBULB RIVET Ø 4.8	4	4	4	4
15	X152646000	PROTECCION SUPERIOR	UPPER PROTECTION	1	1	1	1

Зип Общепит

MOD.	SARTEN BASCULANTE	ZCNA	CONJUNTO FUNCIONAL ELECTRICO
-------------	--------------------------	------	-------------------------------------

ITEM	CODIGO	DENOMINACION	TEXTO	SBE9-10	SBE9-10 M	SBE9-10 IM	SBE9-15 IM
16	X343015000	MICRORRUPTOR 32280001	MICROSWITCH 32280001	1	3	3	3
16	12040850	MICRORRUPTOR 250V AC 16A VDE	MICROSWITCH 250V AC 16A VDE	1	3	3	3
17	X152681000	CAJA PORTA MICRO	MICRO HOLDER BOX	1	1	1	1
18	X152680000	SOPORTE CAJA PORTA MICRO	MICRO HOLDER BOX SUPPORT	1	1	1	1
	Q221342000	REMACHE EXAGONAL M5	HEXAGONAL RIVET M5	2	2	2	2
	Q012031000	TORNILLO EXAGONAL M5x10 A304	HEXAGONAL BOLT M5x10 A304	2	2	2	2
	Q302022000	ARANDELA 16x6x1,2 A304	WASHER 16x6x1.2 A304	2	2	2	2
	Q262030000	ARANDELA GROW. A5 A304	WASHER GROW. A5 A304	2	2	2	2
19	Z700603000	MUELLE 07777	SPRING 07777	1	1	1	1
20	X152682000	EJE PULSADOR MICRO	MICRO BUTTON SHAFT	1	1	1	1
	Q271033000	ARANDELA DE SEGURIDAD Ø6	SAFETY WASHER Ø6	2	2	2	2
21	P453025000	BORNES 10 WDU-10203.O	TERMINALS 10 WDU-10203.O	3	3	3	
21	Z683069000	BORNA 16	TERMINAL 16				3
	Z263302000	BORNA DE PASO AZUL	BLUE THROUGH TERMINAL	1	1	1	
	P453026000	BORNE TIER 10 WPE-10103.O	TERMINAL TIER 10 WPE-10103.O	1	1	1	
	Z263303000	TOPE FINAL	END STOP	1	1	1	
	Z683097000	BORNA PASO WDU16 10204.8	STEP TERMINAL WDU16 10204.8				1
	Z683070000	BORNA A TIERRA WEIDMULLER	TERMINAL TO EARTH WEIDMULL				1
	Z683096000	TOPE FINAL WEW35 10590.0	END STOP WEW35 10590.0				1
	R663055000	GUIA CONTACTOR L-120	CONTACTOR GUIDE L-120	1	1	1	1
	Q419005000	REMACHE 4x8 ALMG3 / ALUMINIO	RIVET 4X8 ALMG3 / ALUMINIUM	2	2	2	2
22	Z203050000	CONTAC. SIRIUS 3R 230V.50-60	CONTACT. SIRIUS 3R 230V.50-60	2	2	2	
22	X183011000	CON.3RT1024-1AN20 230V 50H	CON.3RT1024-1AN20 230V 50H				2
	R663055000	GUIA CONTACTOR L-120	CONTACTOR GUIDE L-120	1	1	1	1
	Q419005000	REMACHE 4x8 ALMG3 / ALUMINIO	RIVET 4X8 ALMG3 / ALUMINIUM	2	2	2	2
23	Z701135000	E.V.SIMP.220V COD.255.208	E.V.SIMP.220V COD.255.208	1	1	1	1
	Z601156000	REGULADOR 8L RO. 254.034	REGULATOR 8L RED 254.034	1	1	1	1
	12096626	REGULADOR 8 L (ROJO)	REGULATOR 8L RED	1	1	1	1
24	X466119000	CONJUNTO TUBO LLENADO CR	FILLER PIPE ASSEMBLY CR	1	1	1	1
	Q152004000	TORN. APLASTADO M5x13 A304	HEXAGONAL FLAT SCREW M5x13	2	2	2	2

Зип Общепит

MOD. SARTEN BASCULANTE vsezip.ru ЗОНА CONJUNTO FUNCIONAL ELECTRICO

ITEM	CODIGO	DENOMINACION	TEXTO	SBE9-10	SBE9-10 M	SBE9-10 IM	SBE9-15 IM
S/Nº	3676900000	TUBO GOMA NEGRA D 17*10	BLACK RUBBER PIPE 17*10	1	1	1	1
	Q881308000	ABRAZADERA 8-14L	CLAMP 8-14L	2	2	2	2
25	X142651000	CUBIERTA BORNAS SBE-910	TERMINAL COVER SBE-910	1	1	1	—
25	X422616000	CUBIERTA BORNAS SBE-915	TERMINAL COVER SBE-915	—	—	—	1
	Q012032000	TORNILLO EXAGONAL M5x15 A304	HEXAGONAL BOLT M5x15 A304	3	3	3	3
	Q262030000	ARANDELA GROW. A5 A304	WASHER GROW. A5 A304	3	3	3	3
	Q221342000	REMACHE EXAGONAL M5	HEXAGONAL RIVET M5	5	5	5	5
26	X142660000	TAPA CUBIERTA BORNAS SBE-910	TERMINAL COVER LID SBE-910	1	1	—	—
26	X142652000	TAPA CUBIER. BORNAS SBE-910 I	TERMINAL COVER LID SBE-910 I	—	—	1	—
26	X422617000	TAPA CUBIER. BORNAS SBE-915	TERMINAL COVER LID SBE-915	—	—	—	1
	X402601000	ESCUADRA SEPARADOR RESIST.	RESIST. DIVIDER BRACKET	2	2	2	2
	Q012032000	TORNILLO EXAGONAL M5x15 A304	HEXAGONAL BOLT M5x15 A304	5	5	5	5
	Q262030000	ARANDELA GROW. A5 A304	WASHER GROW. A5 A304	5	5	5	5
	Q419005000	REMACHE 4x8 ALMG3 / ALUMINIO	RIVET 4X8 ALMG3 / ALUMINIUM	3	3	3	3
27	X142609000	AMARRE AISLANTE	INSULATION FASTENING	3	3	3	3
28	X142653000	PROTECCION AGUA SBE-910 I	WATER PROTECTION SBE-910 I	—	—	1	—
28	X422618000	PROTECCION AGUA SBE-915	WATER PROTECTION SBE-915	—	—	—	1
29	X142656000	AISLANTE 730X520X5	INSULATION 730X520X5	1	1	1	—
29	X083016000	BARLAN 575X515X5	BARLAN 575X515X5	—	—	—	2
30	X143010000	RESISTENCIA SBE9-00	RESISTOR SBE9-00	6	6	6	9
S/Nº	X142620000	AMARRE RESISTENCIAS SBE9-00	RESISTOR FASTENING SBE9-00	6	6	6	9
	Q162050000	TUERCA EXAGONAL M8x1 INOX.	HEXAGONAL NUT M8x1 INOX.	18	18	18	27
	Q302024000	ARANDELA Ø44x9x1,5	WASHER Ø44x9x1.5	18	18	18	27
31	X142650000	CUBIERTA RESISTENC. SBE9-10	RESISTOR COVER SBE9-10	1	1	1	—
31	X422615000	CUBIERTA RESISTENC. SBE9-15	RESISTOR COVER SBE9-15	—	—	—	1
32	X342602000	SOPORTE MICRO	MICRO BRACKET	—	1	1	1
	Q221342000	REMACHE EXAGONAL M5	HEXAGONAL RIVET M5	—	2	2	2
	Q012031000	TORNILLO EXAGONAL M5x10 A304	HEXAGONAL BOLT M5x10 A304	—	2	2	2
	Q302022000	ARANDELA 16x6x1,2 A304	WASHER 16x6x1.2 A304	—	2	2	2

Simb/LENG		ESPAÑOL	ENGLISH	FRANÇAIS	DEUTSCH
C1, C2	=	Contactador Calentamiento	Contacteur Chauffe	Heating Contactor	Heizschütz
CN	=	Control de Nivel de agua	Control of water Level	Commanche de niveau d'eau	Steuerung des Wasserspi
E	=	Generador de Chispa	Spark generator	Générateur d'étincelle	Funkengenerator
IB	=	Micro tope bajada	Microswitch of lowered Limit	Microcontact de la limite abaissée	Mikroschalter der gesenkt
IG	=	Interruptor general	General switch	Commutateur général	Allgemeiner Schalter
IGV	=	Interruptor electrovalvulas de agua	Switch electrovalvula water	Commutateur l'eau d'electrovalvula	Schalten Sie electrovalvula
IE	=	Pulsador de Encendido	Ignition Switch	Commutateur d'allumage	Zündung-Schalter
IMB	=	Pulsador bajada	lowered switch	commutateur abais	gesenkter Schalter
IMS	=	Pulsador subida	Raised switch	Commutateur augmenté	Angehobener Schalter
IP	=	Micro seguridad	security microswitch	microcontact de sécurité	Sicherheitsmikroschalter
IS	=	Micro tope subida	Microswitch of rise Limit	Microcontact de la limite d'élévation	Mikroschalter der Aufstieg
L1	=	Lámpara marcha	Operation Light	Lumière d'opération	Betriebs-Licht
L2	=	Lámpara calentamiento	Heating Light	Lumière de chauffage	Heizungs-Licht
M	=	Motor de elevacion	Motor of elevation	Moteur d'altitude	Motor des Aufzugs
P	=	Presostato de Camara	Water Level Switch	Commutateur de niveau d'eau	Wasserspiegel-Schalter
PR	=	Puente rectificador	Electrical bridge rectifier	Pont redresseur électrique	Elektrischer Brückengleich
R	=	Resistencia Calentamiento.	Resistance Chauffe	Heating Resistors	Widerstand Aufheizung
RE	=	Regulador Energia	Regulator of Energy	Régulateur d'énergie	Regler von Energie
T	=	Termostato	Thermostat	Thermostat	Thermostat
TRF	=	Transformador	Transformer	Transformateur	Transformator
TS	=	Termostato de seguridad	Security Thermostat	Thermostat de sécurité	Sicherheits-Thermostat
TRP	=	Termopar	Thermocouple	Thermocouple	Thermoelement
VG1,VG2	=	ElectroVálvula gas	Electrical gas valve	Clapet à gaz électrique	Elektrisches Gichtventil
V1	=	Valvula Agua CALIENTE	ElectroValve of Hot Water	Électrovalve d'eau chaude	Elektroventil des Heißwas
V2	=	Valvula Agua FRIA	ElectroValve of cold Water	Électrovalve d'eau froide	Elektroventil des kalten W
V3	=	Valvula Agua Caldera	electrovalve of water boiler	électrovalve de chauffe-eau	Elektroventil des Warmwa
	=	COLORES	COLOUR	COULEURS	FARBEN
a	=	Azul	Blue	Bleu	Blau
am	=	Amarillo	Yellow	Jaune	Gelb
am/ve	=	Amarillo/verde	Yellow / green	Jaune / vert	Gelb/grün
b	=	Blanco	White	Blanc	Weiß
g	=	Gris	Grey	Gris	Grau
m	=	Marrón	Brown	Marron	Braun
n	=	Negro	Black	Noir	Schwarz
na	=	Naranja	Orange	Orange	Orange
r	=	Rojo	Red	Rouge	Rot
rs	=	Rosa	Pink	Rose	Rosa
ve	=	Verde	Green	Vert	Grün
vi	=	Violeta	Purple	Violet	Violett