

Зип Общепит

vsezip.ru

DESPIECE TECNICO

+7(812)987-08-81

Sarten basculante a gas
Gas tilting Bratt Pan
Sauteuse basculante a gaz
Gas-kippbratpfannen
Brasiere a gas
Fritadeira baculante a gás

GAMA 900

Modelos:

SBG9-10

SBG9-10 I

SBG9-10 M

SBG9-10 I M

SBG9-15 I M

Marzo 2009 March

Revisado Marzo 2014 March Revised

FAGOR 

FAGOR INDUSTRIAL

Зип Общепит

vsezip.ru

+7(812)987-08-81

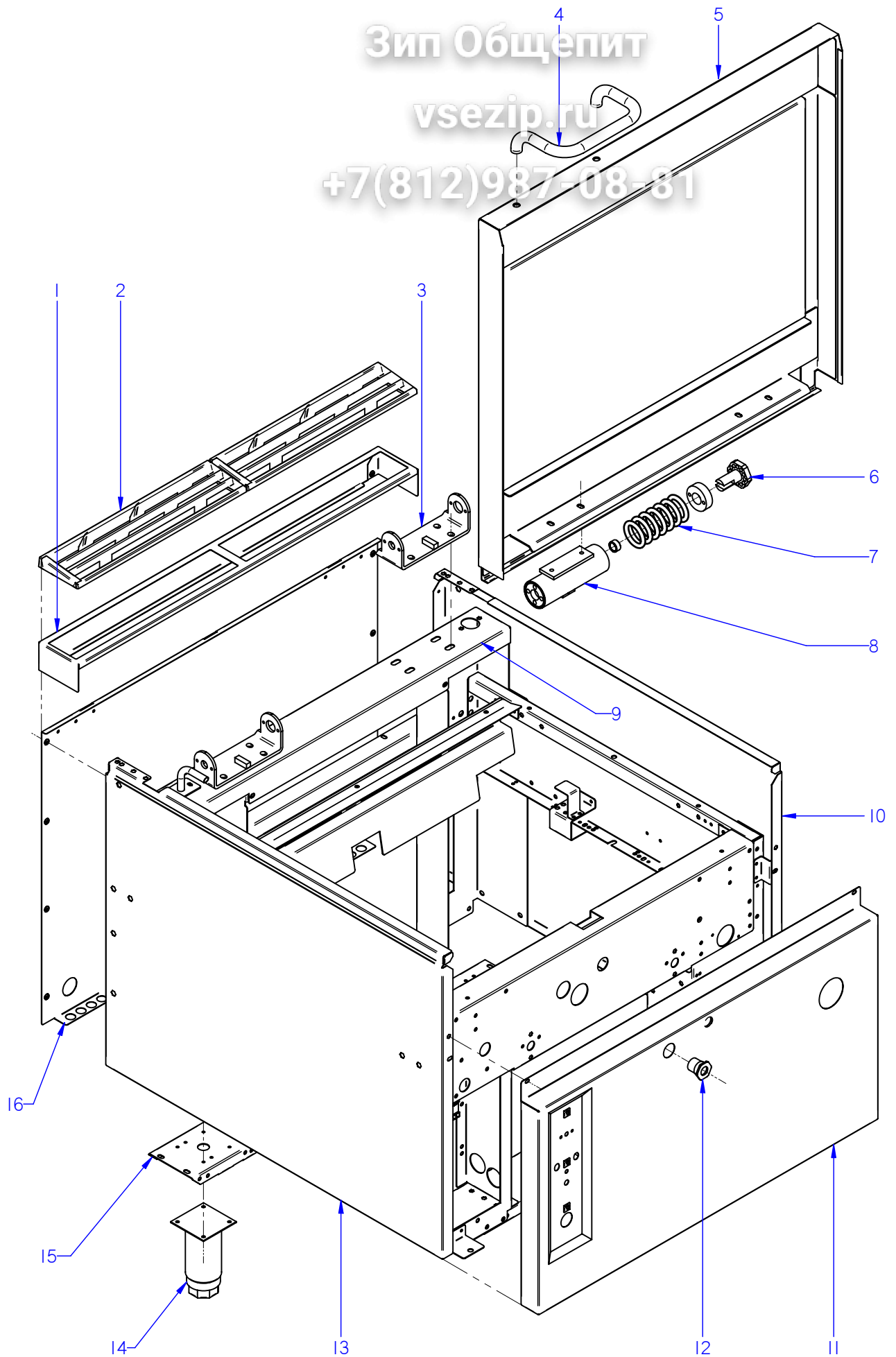

ITEM MARCADO EN COLOR = REPUESTO RECOMENDADO
COLOURED ITEM = RECOMMENDED SPARE PART

N plano	Firma	Fecha	Aparato	MUEBLE	Lamina	Fagor Industrial S.Coop. FAGOR
C-2180	<i>(Signature)</i>	2009-03	SARTEN BASCULANTE G-900		1	Oñate

MOD.		SARTEN BASCULANTE		ZONA		MUEBLE			
ITEM	CODIGO	DENOMINACION	TEXTO	SBG9-10 M	SBG9-10 S	SBG9-10 MS	SBG9-15 M	SBG9-15 MS	
1	R205439000	SOPORTE EMBELLECEDOR 1M	TRIM SUPPORT 1M	1	1				
1	R205440000	SOPORTE EMBELLECEDOR 1,5M	1.5 M TRIM SUPPORT				1	1	
	Q419005000	REMACHE 4x8 ALMG3 / ALUMINIO	RIVET 4X8 ALMG3 / ALUMINIUM	2	2		2	2	
2	R205425000	EMBELLECEDOR ESMALTE	ENAMEL TRIM	2	2		3	3	
3	X286102000	SOPORTE BISAGRA COMPLETA	COMPLETE HINGE SUPPORT	2	2		2	2	
3	X086106000	SOPORTE BISAGRA COMPLETA	COMPLETE HINGE SUPPORT	2	2		2	2	
	Q012053000	TORNILLO EXAGONAL M8x20 A304	HEXAGONAL BOLT M8x20 A304	8	8		8	8	
	Q262050000	ARANDELA GROW. A8 A304	WASHER GROW. A8 A304	8	8		8	8	
	Q232050000	ARANDELA A8	WASHER A8	8	8		8	8	
	Q162050000	TUERCA EXAGONAL M8x1 INOX.	HEXAGONAL NUT M8x1 INOX.	8	8		8	8	
4	S036123000	ASA DE TAPA	COVER HANDLE	1	1		1	1	
	X152809000	TORNILLO SUJEC. ASA DE TAPA	LID HANDLE FASTENING BOLT	2	2		2	2	
	Q302027000	ARANDELA 25x6x8,4x2	WASHER 25X6X8.4X2	2	2		2	2	
5	X022825000	TAPA COMPLETA GAMA 900 1M	LID COMPLETE RANGE 900 1M	1	1				
5	12098814	TAPA COMPLETA GAMA 900 1M	LID COMPLETE RANGE 900 1M	1	1				
5	X082813000	TAPA COMPLETA GAMA 900 1,5M	LID COMPLETE RANGE 900 1.5M				1	1	
5	12098812	TAPA COMPLETA GAMA 900 1,5M	LID COMPLETE RANGE 900 1.5M				1	1	
	Q012051000	TORNILLO EXAGONAL M8x10	HEXAGONAL BOLT M8x10	4	4		4	4	
6	S116120000	TENSOR MUELLE	TENSIONING SPRING	2	2		2	2	
	Q012042000	TORNILLO EXAGONAL M6x15	HEXAGONAL BOLT M6x15	4	4		4	4	
	Q262040000	ARANDELA GROW. A6 A304	WASHER GROW. A6 A304	4	4		4	4	
	S116118000	CASQUILLO	BUSHING	2	2		2	2	
7	S116121000	RESORTE TAPA 07199	SPRING COVER 07199	2	2		2	2	
8	X156101000	BISAGRA COMPLETA	COMPLETE HINGE	2	2		2	2	
	S116126000	COJINETE CILINDRICO	CYLINDRICAL BEARING	2	2		2	2	
	S116119000	GIRO DE ASA	HANDLE ROTATION	2	2		2	2	
	Q012041000	TORNILLO EXAGONAL M6x10 A304	HEXAGONAL BOLT M6x10 A304	4	4		4	4	
9	X020108000	CUBIERTA PUENTE	BRIDGE COVERING	1	1				
9	X080103000	CUBIERTA PUENTE G.900 1.5M	BRIDGE COVERING G.900 1.5M				1	1	
	Q411302000	REMACHE MONOBOLT Ø6.35	MONOBOLT RIVET D6.35	6	6		6	6	
	Q221342000	REMACHE EXAGONAL M5	HEXAGONAL RIVET M5	2	2		2	2	

MOD.	SARTEN BASCULANTE	ZONA	MUEBLE						
		vsezip.ru							
		+7(812)987-08-81							
ITEM	CODIGO	DENOMINACION	TEXTO	SBG9-10	SBG9-10 M	SBG9-10 S	SBG9-10 MS	SBG9-15 M	SBG9-15 MS
10	X042804000	PANEL LATERAL DERECHO	RIGHT SIDE PANEL	1	-	-	-	1	-
10	X022818000	PANEL LATERAL DERECHO SUSP.	SUSP. RIGHT SIDE PANEL	-	-	1	-	-	1
	Q221343000	REMACHE EXAGONAL M6	HEXAGONAL RIVET M6	11	-	-	-	11	-
	Q012042000	TORNILLO EXAGONAL M6x15	HEXAGONAL BOLT M6x15	4	-	-	-	4	-
	Q262040000	ARANDELA GROW. A6 A304	WASHER GROW. A6 A304	4	-	-	-	4	-
	Q221342000	REMACHE EXAGONAL M5	HEXAGONAL RIVET M5	3	-	3	-	3	3
	Q152004000	TORNILLO APLASTADO M5x13	FLAT HEAD SCREW M5X13	1	-	1	-	1	1
	Q162030000	TUERCA EXAGONAL M5	HEXAGONAL NUT M5	-	-	1	-	-	1
11	X022829000	PANEL FRONTAL SBG9-10	FRONT PANEL SBG9-10	1	-	1	-	-	-
11	X022830000	PANEL FRONTAL SBG9-10 M	FRONT PANEL SBG9-10 M	1	-	1	-	-	-
11	X042810000	PANEL FRONTAL SBE9-10	FRONT PANEL SBE9-10	-	-	-	-	-	-
11	X042809000	PANEL FRONTAL SBE9-10 M	FRONT PANEL SBE9-10 M	-	-	-	-	-	-
11	X082814000	PANEL FRONTAL SBG9-15	FRONT PANEL SBG9-15	-	-	-	-	1	1
11	X082815000	PANEL FRONTAL SBE9-15	FRONT PANEL SBE9-15	-	-	-	-	-	-
	Q152004000	TORNILLO APLASTADO M5X13	FLAT HEAD SCREW M5X13	2	-	2	-	2	2
	Q012042000	TORNILLO EXAGONAL M6x15	HEXAGONAL BOLT M6x15	2	-	2	-	2	2
	Q262040000	ARANDELA GROW. A6 A304	WASHER GROW. A6 A304	2	-	2	-	2	2
12	S112804000	EMBELLECEDOR TUBO	PIPE TRIM	1	-	1	-	1	1
13	X042803000	PANEL LATERAL IZQUIERDO	LEFT SIDE PANEL	1	-	-	-	1	-
13	X022817000	PANEL LATERAL IZQUIERDO SUSP.	SUSP. LEFT SIDE PANEL	-	-	1	-	-	1
	Q221343000	REMACHE EXAGONAL M6	HEXAGONAL RIVET M6	11	-	-	-	11	-
	Q012042000	TORNILLO EXAGONAL M6x15	HEXAGONAL BOLT M6x15	4	-	-	-	4	-
	Q262040000	ARANDELA GROW. A6 A304	WASHER GROW. A6 A304	4	-	-	-	4	-
	Q221342000	REMACHE EXAGONAL M5	HEXAGONAL RIVET M5	3	-	3	-	3	3
	Q152004000	TORNILLO APLASTADO M5x13	FLAT HEAD SCREW M5X13	1	-	1	-	1	1
	Q162030000	TUERCA EXAGONAL M5	HEXAGONAL NUT M5	-	-	1	-	-	1
14	X260151000	PATA REGULABLE	ADJUSTABLE LEG	4	-	-	-	4	-
	Q411304000	REMACHE AVIBULB Ø 4,8	AVIBULB RIVET Ø 4.8	16	-	-	-	16	-

Зип Общепит

MOD. SARTEN BASCULANTE

zcpna vsezip.ru

MUEBLE

ITEM	CODIGO	DENOMINACION	TEXTO		SBG9-10	SBG9-10 M	SBG9-10 S	SBG9-10 MS	SBG9-15 M	SBG9-15 MS	
15	X022603000	LISTON SOPORTE PATAS 1M	LEG SUPPORT STRIP 1M		2	1					
15	X082608000	LISTON SOPORTE PATAS 1,5M	LEG SUPPORT STRIP 1.5 M						2	1	
	Q221342000	REMACHE EXAGONAL M5	HEXAGONAL RIVET M5		4	2			4	4	
	Q221343000	REMACHE EXAGONAL M6	HEXAGONAL RIVET M6		2	2			2	2	
16	U562853000	PANEL POSTERIOR 1M	REAR PANEL 1M		1						
16	S372816000	PANEL POSTERIOR 1M SUSPEND.	REAR PANEL 1M SUSPENDED			1					
16	U582852000	PANEL POSTERIOR 1,5M	REAR PANEL 1.5 M						1		
16	X412802000	PANEL POSTERIOR 1,5M SUSPEN.	REAR PANEL 1.5 M SUSPENDED							1	
	Q419005000	REMACHE 4x8 ALMG3 / ALUMINIO	RIVET 4X8 ALMG3 / ALUMINIUM		8	8			8	8	

Зип Общепит

vsezip.ru

+7(812)987-08 81

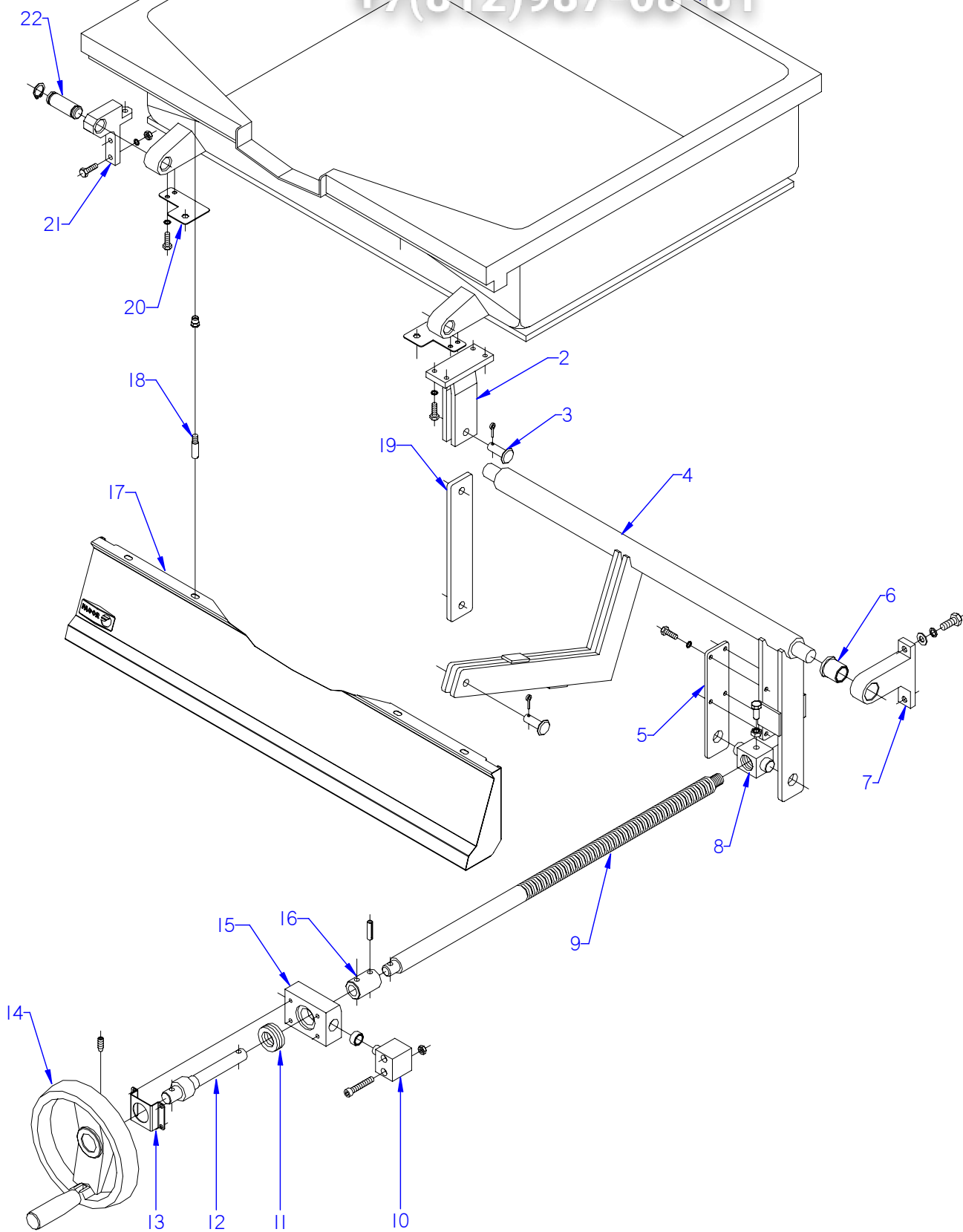

ITEM MARCADO EN COLOR = REPUESTO RECOMENDADO
COLOURED ITEM = RECOMMENDED SPARE PART

N plano	Firma	Fecha	Aparato	CUBA (ELEVACION MANUAL)	Lamina	Fagor Industrial S.Coop. FAGOR
C-2181	<i>[Signature]</i>	2009-03	SARTEN BASCULANTE G 900		2	Oñate

MOD.		SARTEN BASCULANTE		ZONA	CUBA (ELEVACION MANUAL)		
ITEM	CODIGO	DENOMINACION	TEXTO	SBG9-10	SBG9-10 I		
1	X156155000	CUBA FUNDIDA SBG9-10	CAST IRON TUB SBG9-10	1			
1	X146125000	CUBA FUNDIDA SBG9-10	CAST IRON TUB SBG9-10	1			
1	12007698	CUBA FUNDIDA SBG9-10	CAST IRON TUB SBG9-10	1			
1	X146133000	CUBA INOXIDABLE SARTEN 910	INOX TUB FRYPAN 910		1		
2	X156157000	HORQUILLA DE GIRO	ROTATION FORK	1			
	Q012043000	TORNILLO EXAGONAL M6x20 A304	HEXAGONAL BOLT M6x20 A304	4			
	Q262040000	ARANDELA GROW. A6 A304	WASHER GROW. A6 A304	4			
3	X156123000	BULON Ø12	PIN Ø12	2	2		
	Q352024000	PASADOR DE ALETAS Ø4x25	COTTER PIN Ø4x25	2	2		
4	X156148000	BRAZO ELEVADOR COMPLETO	COMPLETE ELEVATION ARM	1	1		
	Q131555000	VARILLA ROSCADA M8x30	THREADED ROD M8X30				
	Q131558000	VARILLA ROSCADA M8x60	THREADED ROD M8X60				
	Q162050000	TUERCA EXAGONAL M8x1	HEXAGONAL NUT M8x1				
5	X156149000	BRAZO LATERAL	SIDE ARM	1	1		
	Q012042000	TORNILLO EXAGONAL M6x15	HEXAGONAL BOLT M6x15	4	4		
	Q262040000	ARANDELA GROW. A6 A304	WASHER GROW. A6 A304	4	4		
6	X109550000	COJINETE SELFOIL B11	BEARING SELFOIL B11	2	2		
7	X150108000	SOPORTE DE GIRO	ROTATION SUPPORT	2	2		
	Q012063000	TORNILLO EXAG. M10x20 A304	HEX BOLT M10x20 A304	4	4		
	Q261060000	ARANDELA MUELLE A10	SPRING WASHER A10	4	4		
	Q232060000	ARANDELA A10	WASHER A10	4	4		
8	X156154000	TUERCA HUSILLO	SPINDLE NUT	1	1		
8	X146136000	TUERCA HUSILLO	SPINDLE NUT	1	1		
8	12046610	TUERCA HUSILLO	SPINDLE NUT	1	1		
	Q011364000	TORNILLO EXAG. M10x25	HEX BOLT M10x25	1	1		
	Q161360000	TUERCA EXAG. M10 H. ZINCADA	HEXAG. SCREW M10 H. ZINC-CO	1	1		
9	X156152000	HUSILLO GAMA 900	SPINDLE RANGE 900	1	1		
9	X146134000	HUSILLO GAMA 900	SPINDLE RANGE 900	1	1		
9	12046627	HUSILLO GAMA 900	SPINDLE RANGE 900	1	1		

MOD.		SARTEN BASCULANTE		ZONA		CUBA (ELEVACION MANUAL)			
ITEM	CODIGO	DENOMINACION	TEXTO	SBG9-10	SBG9-10 I				
10	X156113000	PIVOTE DE GIRO	ROTATION PIVOT	2	2				
	S116126000	COJINETE CILINDRICO	CYLINDRICAL BEARING	2	2				
	Q052046000	TORNILLO ALLEN M6x40 A304	ALLEN BOLT M6x40 A304	4	4				
	Q162040000	TUERCA EXAGONAL M6	HEXAGONAL NUT M6	4	4				
11	X156125000	RODAMIENTO 51204	BEARING 51204	1	1				
12	X156161000	EJE VOLANTE COMPLETO	COMPLETE FLYSHAFT	1	1				
13	X152619000	SOPORTE EJE VOLANTE	FLYSHAFT SUPPORT	1	1				
	Q012041000	TORNILLO EXAGONAL M6x10 A304	HEXAGONAL BOLT M6x10 A304	4	4				
	Q262040000	ARANDELA GROW. A6 A304	WASHER GROW. A6 A304	4	4				
14	X156139000	VOLANTE ELESA	FLYSHAFT ELESA	1	1				
	Q131552000	VARILLA ROSCADA M8x15	THREADED ROD M8X15	2	2				
15	X156114000	SOPORTE RODAMIENTO	BEARING SUPPORT	1	1				
16	X156115000	CASQUILLO	BUSHING	1	1				
	Q371027000	MANGUITO DE SUJECCION Ø8x30	FASTENING SLEEVE Ø8x30	2	2				
17	X022822000	PORTAMANDOS SARTEN FUN. 1M	C.IRON FRYPAN CONTROL HOLD	1	—				
17	X022824000	PORTAMANDOS SARTEN INOX. 1M	INOX FRYPAN CONTROL HOLDEP	—	1				
	U022836000	ESCUDO FAGOR	FAGOR EMBLEM	1	1				
	Q012042000	TORNILLO EXAGONAL M6x15	HEXAGONAL BOLT M6x15	2	2				
	Q301304000	ARANDELA PLANA 23x6,5x2	FLAT WASHER 23X6.5X2	2	2				
	Q221023000	CLIP SUJECION RÁPIDA D-5	QUICK FASTENING CLIP D-5	2	2				
18	Q151336000	TORNILLO SOPORTE GUIAS	GUIDE SUPPORT BOLT	2	2				
19	X156151000	BRAZO	ARM	1	1				
20	X156156000	AMARRE PANEL PORTAMANDOS	CONTROL HOLDER PANEL FAST.	2	—				
	Q012041000	TORNILLO EXAGONAL M6x10 A304	HEXAGONAL BOLT M6x10 A304	4	—				
	Q262040000	ARANDELA GROW. A6 A304	WASHER GROW. A6 A304	4	—				
21	X156145000	SOPORTE GIRO CUBA	TUB ROTATION SUPPORT	2	2				
	Q012043000	TORNILLO EXAGONAL M6x20 A304	HEXAGONAL BOLT M6x20 A304	6	6				
	Q262040000	ARANDELA GROW. A6 A304	WASHER GROW. A6 A304	6	6				
	Q162040000	TUERCA EXAGONAL M6	HEXAGONAL NUT M6	6	6				
22	X109511000	BULON LATON	BRASS BOLT	2	2				
	Q301020000	ANILLO DE SEGURIDAD 20x1,2	CIRCLIP 20x1.2	4	4				

Зип Общепит

vsezip.ru

+7(812)987-08-81

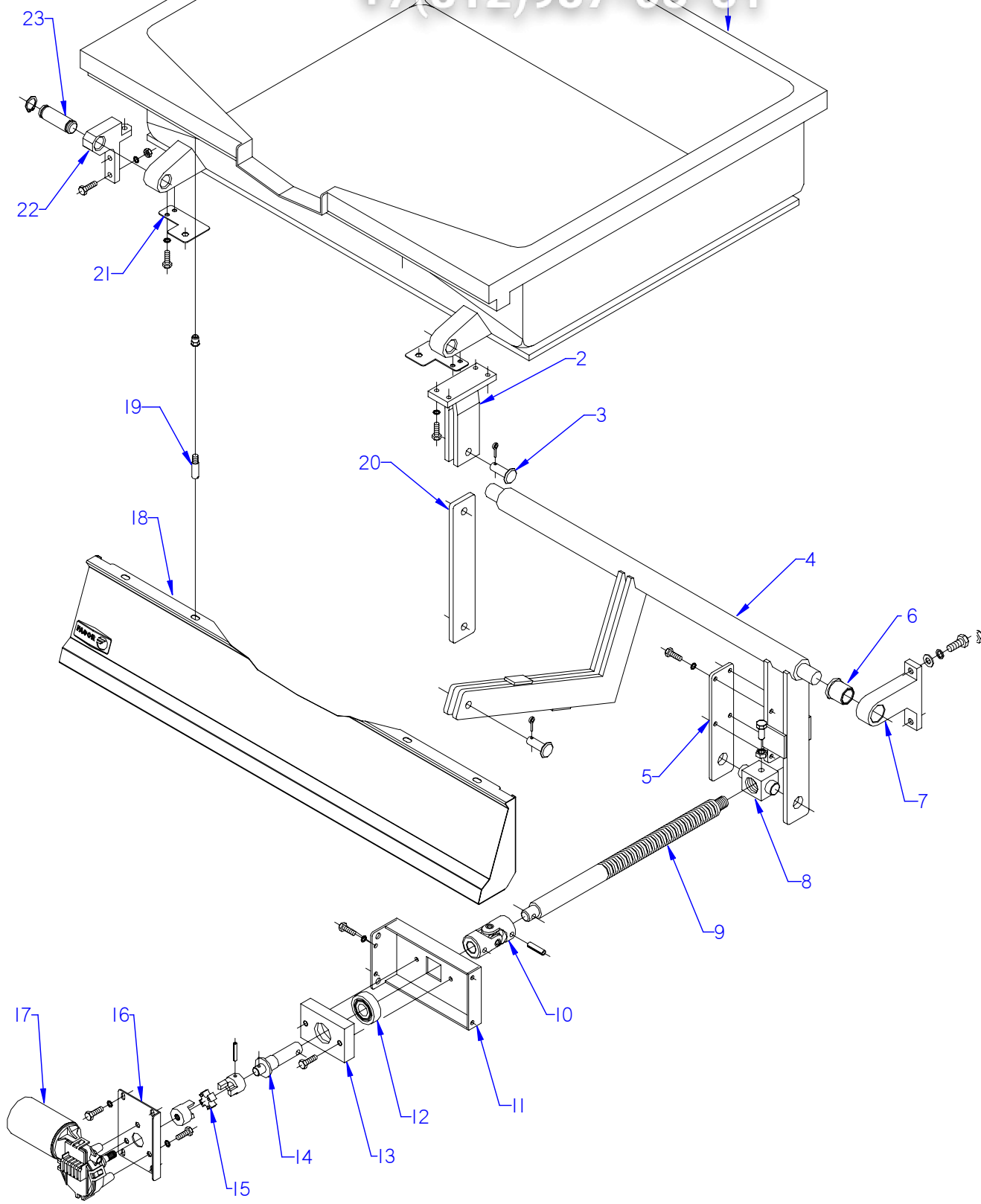

ITEM MARCADO EN COLOR = REPUESTO RECOMENDADO
COLOURED ITEM = RECOMMENDED SPARE PART

N plano	Firma	Fecha	Aparato	CUBA (ELEVACION MOTOR)	Lamina	Fagor Industrial S.Coop. FAGOR
C-2182	<i>(Signature)</i>	2009-03	SARTEN BASCULANTE G 900	3	Oñate	

MOD.		SARTEN BASCULANTE		ZONA	CUBA (ELEVACION MOTOR)		
ITEM	CODIGO	DENOMINACION	TEXTO	SBG9-10 IM	SBG9-10 IM	SBG9-15 IM	
1	X156155000	CUBA FUNDIDA SBG9-10	CAST IRON TUB SBG9-10	1	-	-	
1	X146125000	CUBA FUNDIDA SBG9-10	CAST IRON TUB SBG9-10	1	-	-	
1	X146133000	CUBA INOXIDABLE SBG9-10	INOX TUB SBG9-10	-	1	-	
1	X146125000	CUBA FUNDIDA SBE9-10	CAST IRON TUB SBE9-10	-	-	-	
1	X146133000	CUBA INOXIDABLE SBE9-10	INOX TUB SBE9-10	-	-	-	
1	X286111000	CUBA INOXIDABLE SBG9-15	INOX TUB SBG9-15	-	-	1	
	Q221343000	REMACHE EXAGONAL M6	HEXAGONAL RIVET M6	2	2	2	
	Q221343000	REMACHE EXAGONAL M6	HEXAGONAL RIVET M6	2	2	2	
2	X156157000	HORQUILLA DE GIRO	ROTATION FORK	1	-	-	
	Q012043000	TORNILLO EXAGONAL M6x20 A304	HEXAGONAL BOLT M6x20 A304	4	-	-	
	Q262040000	ARANDELA GROW. A6 A304	WASHER GROW. A6 A304	4	-	-	
3	X156123000	BULON Ø12	PIN Ø12	2	2	2	
	Q352024000	PASADOR DE ALETAS Ø4x25	COTTER PIN Ø4x25	2	2	2	
4	X156148000	BRAZO ELEVADOR COMP.SB9-10	COMP. ELEVATION ARM SB9-10	1	1	-	
4	X286106000	BRAZO ELEVADOR COMP.SBG9-15	COMP. ELEVATION ARM SBG9-15	-	-	1	
4	X426103000	BRAZO ELEVADOR COMP.SBE9-15	COMP. ELEVATION ARM SBE9-15	-	-	-	
5	X156149000	BRAZO LATERAL	SIDE ARM	1	1	1	
	Q012042000	TORNILLO EXAGONAL M6x15	HEXAGONAL BOLT M6x15	4	4	4	
	Q262040000	ARANDELA GROW. A6 A304	WASHER GROW. A6 A304	4	4	4	
6	X109550000	COJINETE SELFOIL B11	BEARING SELFOIL B11	2	2	2	
7	X150108000	SOPORTE DE GIRO	ROTATION SUPPORT	2	2	2	
	Q012063000	TORNILLO EXAG. M10x20 A304	HEX BOLT M10x20 A304	4	4	4	
	Q261060000	ARANDELA MUELLE A10	SPRING WASHER A10	4	4	4	
	Q232060000	ARANDELA A10	WASHER A10	4	4	4	
8	X156154000	TUERCA HUSILLO	SPINDLE NUT	1	1	1	
8	X146136000	TUERCA HUSILLO	SPINDLE NUT	1	1	1	
8	12046610	TUERCA HUSILLO	SPINDLE NUT	1	1	1	
	Q011364000	TORNILLO EXAG. M10x25	HEX BOLT M10x25	1	1	1	
	Q161360000	TUERCA EXAG. M10 H. ZINCADA	HEXAG. SCREW M10 H. ZINC-CO	1	1	1	

MOD.		SARTEN BASCULANTE		ZONA	CUBA (ELEVACION MOTOR)		
ITEM	CODIGO	DENOMINACION	TEXTO	SBG9-10 M	SBG9-10 IM	SBG9-15 IM	
9	X156152000	HUSILLO GAMA 900	SPINDLE RANGE 900	1	1	1	
9	X146134000	HUSILLO GAMA 900	SPINDLE RANGE 900	1	1	1	
9	12046627	HUSILLO GAMA 900	SPINDLE RANGE 900	1	1	1	
10	X126114000	JUNTA UNIVERSAL 107A	UNIVERSAL JOINT 107A	1	1	1	
	Q371027000	MANGUITO DE SUJECCION Ø8x30	FASTENING SLEEVE Ø8x30	2	2	2	
11	X342607000	SOPORTE EJE MOTOR	MOTOR SHAFT SUPPORT	1	1	1	
	Q012032000	TORNILLO EXAGONAL M5x15 A304	HEXAGONAL BOLT M5x15 A304	4	4	4	
	Q262030000	ARANDELA GROW. A5 A304	WASHER GROW. A5 A304	4	4	4	
12	X346109000	RODAMIENTO SKF	SKF BEARING	1	1	1	
13	X346105000	SOPORTE RODAMIENTO	BEARING SUPPORT	1	1	1	
	Q012044000	TORNILLO EXAGONAL M6x25	HEXAGONAL BOLT M6x25	2	2	2	
14	X346106000	EJE MOTOR	MOTOR SHAFT	1	1	1	
15	X346107000	ACOPLAMIE. ELASTICO LOVEJOY	ELASTIC LOVEJOY COUPLING	1	1	1	
	Q371032000	PASADOR ELASTICO Ø5x30	ELASTIC PIN Ø5x30	2	2	2	
16	X342603000	SOPORTE MOTOR	MOTOR SUPPORT	1	1	1	
	Q012042000	TORNILLO EXAGONAL M6x15	HEXAGONAL BOLT M6x15	4	4	4	
	Q262040000	ARANDELA GROW. A6 A304	WASHER GROW. A6 A304	4	4	4	
17	X343020000	MOTORREDUCTOR (BOSCH)	GEAR MOTOR (BOSCH)	1	1	1	
	Q012042000	TORNILLO EXAGONAL M6x15	HEXAGONAL BOLT M6x15	3	3	3	
	Q262040000	ARANDELA GROW. A6 A304	WASHER GROW. A6 A304	3	3	3	
18	X022822000	PORTAMANDOS COMPL. SB9-10	COMPL. CONTROL HOLDER SB9	1			
18	X022824000	PORTAMANDOS COMPL. SB9-10 I	COMPL. CONTROL HOLDER SB9		1		
18	X082812000	PORTAMANDOS COMPL. SB9-15 I	COMPL. CONTROL HOLDER SB9			1	
	U022836000	ESCUDO FAGOR	FAGOR EMBLEM	1	1	1	
	Q301304000	ARANDELA PLANA 23x6,5x2	FLAT WASHER 23X6.5X2	2	2	2	
	Q012042000	TORNILLO EXAGONAL M6x15	HEXAGONAL BOLT M6x15	2	2	2	
	Q221023000	CLIP SUJECIÓN RÁPIDA D-5	QUICK FASTENING CLIP D-5	2	2	2	
19	Q151336000	TORNILLO SOPORTE GUIAS	GUIDE SUPPORT BOLT	2	2	2	
20	X156151000	BRAZO	ARM	1	1	1	

MOD.	SARTEN BASCULANTE	ZONA	CUBA (ELEVACION MOTOR)
-------------	--------------------------	-------------	-------------------------------

vsezip.ru

+7(812)987-08-81

ITEM	CODIGO	DENOMINACION	TEXTO	SBG9-10 M	SBG9-10 IM	SBG9-15 IM		
21	X156156000	AMARRE PANEL PORTAMANDOS	CONTROL HOLDER PANEL FAST	2	-	-		
	Q012041000	TORNILLO EXAGONAL M6x10 A304	HEXAGONAL BOLT M6x10 A304	4	-	-		
	Q262040000	ARANDELA GROW. A6 A304	WASHER GROW. A6 A304	4	-	-		
22	X156145000	SOPORTE GIRO CUBA	TUB ROTATION SUPPORT	2	2	2		
	Q012043000	TORNILLO EXAGONAL M6x20 A304	HEXAGONAL BOLT M6x20 A304	6	6	6		
	Q262040000	ARANDELA GROW. A6 A304	WASHER GROW. A6 A304	6	6	6		
	Q162040000	TUERCA EXAGONAL M6	HEXAGONAL NUT M6	6	6	6		
23	X109511000	BULON LATON	BRASS BOLT	2	2	2		
	Q301020000	ANILLO DE SEGURIDAD 20x1,2	CIRCLIP 20x1.2	4	4	4		
	Q012032000	TORNILLO EXAGONAL M5x15	HEXAGONAL BOLT M5x15	1	1	1		
	Q012033000	TORNILLO EXAGONAL M5x20	HEXAGONAL BOLT M5x20	1	1	1		

Зип Общепит

vsezip.ru

+7(812)987-08-81

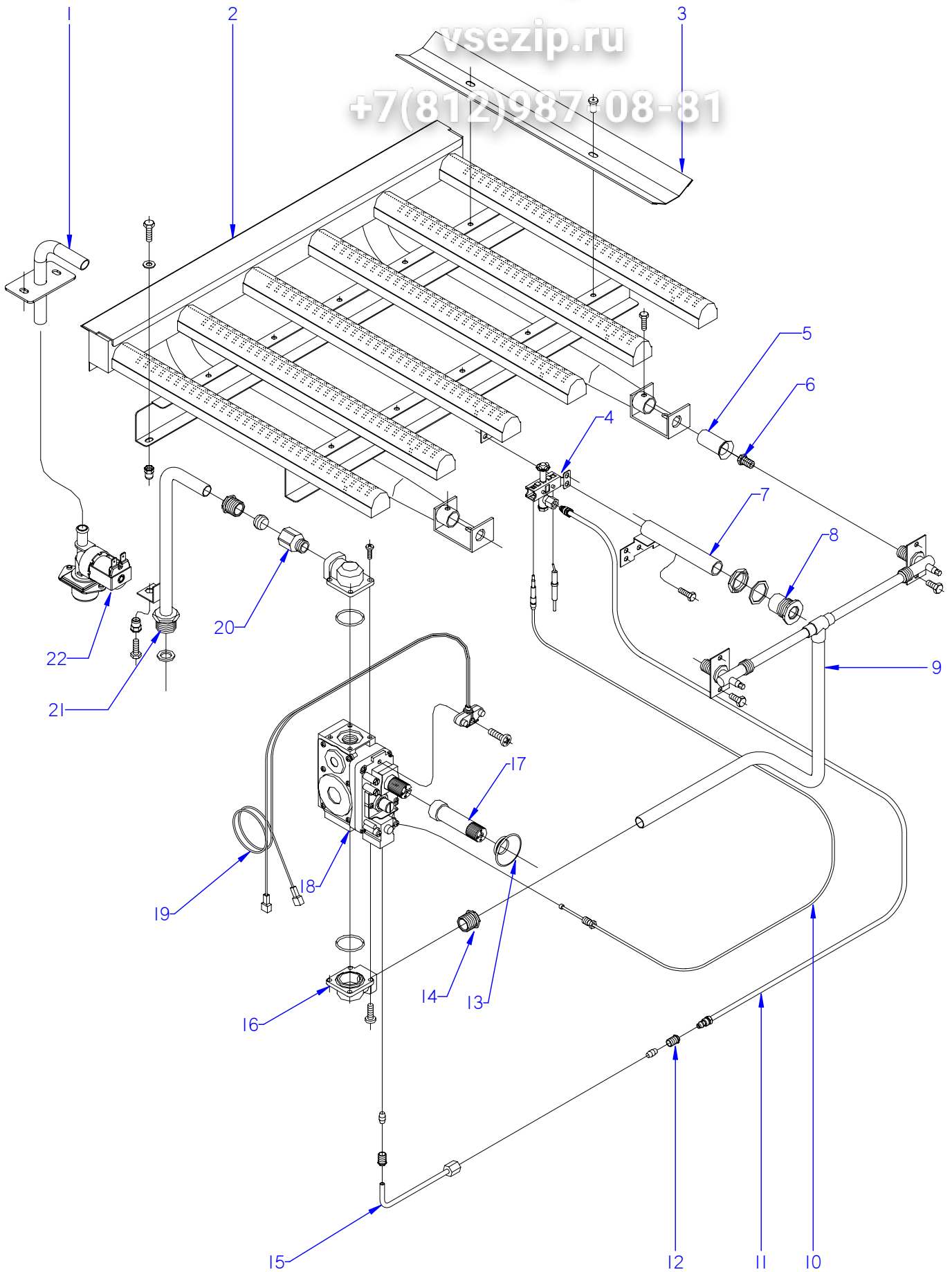

ITEM MARCADO EN COLOR = REPUESTO RECOMENDADO
COLOURED ITEM = RECOMMENDED SPARE PART

N plano	Firma	Fecha	Aparato	CONJUNTO FUNCIONAL DE GAS	Lamina	Fagor Industrial S.Coop. FAGOR
C-2183	<i>(Signature)</i>	2009-03	SARTEN BASCULANTE G-900		4	Oñate

MOD.	SARTEN BASCULANTE	vsezip.ru	CONJUNTO FUNCIONAL DE GAS
-------------	--------------------------	-----------	----------------------------------

ITEM	CODIGO	DENOMINACION	TEXTO	SBG9-10	SBG9-10 S	SBG9-15	SBG9-15 S
1	X466119000	CONJUNTO TUBO LLENADO CR	FILLER PIPE ASSEMBLY CR	1	1	1	1
	Q152004000	TORN. APLASTADO M5x13 A304	HEXAGONAL FLAT SCREW M5x13	2	2	2	2
S/Nº	3676900000	TUBO GOMA NEGRA Ø 17*10	BLACK RUBBER PIPE 17*10	1	1	1	1
	Q881308000	ABRAZADERA 8-14L	CLAMP 8-14L	2	2	2	2
2	X155710000	QUEMADOR COMPLETO SBG9-10	COMPLETE BURNER SBG9-10	1	1	-	-
2	X285710000	QUEMADOR COMPLETO SBG9-15	COMPLETE BURNER SBG9-15	-	-	1	1
3	X155720000	DEFLECTOR LARGO G 900	LONG DEFLECTOR G 900	3	3	6	6
S/Nº	X155721000	DEFLECTOR CORTO G 900	SHORT DEFLECTOR G 900	1	1	1	1
	Q419005000	REMACHE 4x8 ALMG3 / ALUMINIO	RIVET 4X8 ALMG3 / ALUMINIUM	8	8	8	8
4	U322118000	PILOTO COMPLETO 100.062	COMPLETE PILOT LIGHT 100,062	1	1	1	1
	Q012031000	TORNILLO EXAGONAL M5x10 A304	HEXAGONAL BOLT M5x10 A304	2	2	2	2
	Q162030000	TUERCA EXAGONAL M5	HEXAGONAL NUT M5	2	2	2	2
	U442137000	INYECTOR Ø 0,40 GN	INJECTOR Ø 0.40 GN.	1	1	1	1
	X022131000	BUJIA	SPARK PLUG	1	1	1	1
5	U325707000	REGULADOR DE AIRE	AIR REGULATOR	2	2	3	3
	Q012031000	TORNILLO EXAGONAL M5x10 A304	HEXAGONAL BOLT M5x10 A304	2	2	3	3
	Q012031000	TORNILLO EXAGONAL M5x10 A304	HEXAGONAL BOLT M5x10 A304	2	2	3	3
6	U052401000	TOBERA Ø 1,45 (Butano-Propano)	NOZZLE Ø1.45 (BUT-PROP.)	2	2	3	3
6	U262400000	TOBERA Ø 2,15 (Gas Natural)	NOZZLE Ø2.15 (NATURAL GAS)	2	2	-	-
6	1011600000	TOBERA Ø 2,25 (Gas Natural)	NOZZLE Ø2.25 (NATURAL GAS)	-	-	3	3
6	X102403000	TOBERA Ø 4,58 (Gas Villa)	NOZZLE Ø4.58 (City gas)	2	2	-	-
6	9145300000	TOBERA Ø 4.80 (Gas Villa)	NOZZLE Ø4.80 (City gas)	-	-	3	3
7	X155035000	TUBO DE ENCENDIDO COMPLETO	COMPLETE IGNITION PIPE	1	1	1	1
8	S112804000	EMBELLECEDOR TUBO	PIPE TRIM	1	1	1	1
	Q221324000	TUERCA 3/4 GAS	NUT 3/4 GAS	1	1	1	1
	Q306027000	ARANDELA PLANA 33.8X27X1.5	FLAT WASHER 33.8X27X1.5	1	1	1	1
9	X155047000	CONDUCC. QUEMADOR SBG-910	BURNER PIPE SBG-910	1	1	-	-
9	X285023000	CONDUCC. QUEMADOR SBG-915	BURNER PIPE SBG-915	-	-	1	1
	Q306057000	ARANDELA Ø18x12,5x1,5	WASHER Ø18x12.5x1.5	1	1	1	1
	Q153002000	TORNILLO TAPON	CAP BOLT	2	2	3	3
10	U562130000	TERMOPAR L=850	THERMOCOUPLE L=850	1	1	1	1

Зип Общепит

MOD.		SARTEN BASCULANTE		vsezip.ru		CONJUNTO FUNCIONAL DE GAS	
ITEM	CODIGO	DENOMINACION	TEXTO	SBG9-10	SBG9-10 S	SBG9-15	SBG9-15 S
11	X155052000	TUBO PILOTO	PILOT PIPE	1	1		
11	X285025000	TUBO PILOTO	PILOT PIPE			1	1
12	U195009000	MANGUITO EMPALME	CONNECTION HOSE	1	1	1	1
	X205028000	BICONO Ø6	BICONE Ø6	1	1	1	1
13	X152121000	JUNTA VALVULA	VALVE GASKET	1	1	1	1
14	S205023000	MANGUITO DOBLE 1/2	DOUBLE SLEEVE 1/2	1	1	1	1
15	X155043000	TUBO PILOTO A VALVULA COMPL.	PILOT PIPE TO COMPLETE VALVE	1	1	1	1
16	X153004000	CODO 1-2 820 NOV 906.260	L-PIPE 1-2 820 NOV 906.260	2	2	2	2
17	X262100000	ALARGADERO NEG. 999.975	BLACK EXTENSION 999.975	1	1	1	1
18	12097292	VALVULA NOVA 820 REGULADA	VALVE REGULATED NOVA 820	1	1	1	1
18	12024777	ELECTROVALV. 820 NOVA 60 Hz.	SOLENOID VALVE. 820 NOVA 60 Hz.	1	1	1	1
	Q012031000	TORNILLO EXAGONAL M5x10 A304	HEXAGONAL BOLT M5x10 A304	2	2	2	2
	Q302022000	ARANDELA 16x6x1,2 A304	WASHER 16x6x1.2 A304	2	2	2	2
19	R275027000	CABLEADO ELECTROSIT 927.012	WIRING ELECTROSIT 927.012	1	1	1	1
20	X162101000	RACORD 1/2	CONNECTION 1/2	1	1	1	1
	X012105000	BICONO Ø 16 957.008	BICONE Ø 16,957.008	1	1	1	1
	X012104000	MANGUITO 1/2 958.027	HOSE 1/2 958.027	1	1	1	1
21	X155033000	CONDUCCION ENTRADA COMPL.	COMPL. INPUT PIPE	1		1	
21	X245019000	CONDUCCION GENERAL	GENERAL PIPE		1		1
	Q221343000	REMACHE EXAGONAL M6	HEXAGONAL RIVET M6	1	1	1	1
	Q012042000	TORNILLO EXAGONAL M6x15	HEXAGONAL BOLT M6x15	1	1	1	1
	Q302022000	ARANDELA 16x6x1,2 A304	WASHER 16x6x1.2 A304	1	1	1	1
22	Z701135000	E.V.SIMP.220V COD.255.208	E.V.SIMP.220V COD.255.208	1	1	1	1
	Z601156000	REGULADOR 8L RO. 254.034	REGULATOR 8L RED 254.034	1	1	1	1
	12096626	REGULADOR 8 L (ROJO)	REGULATOR 8L RED	1	1	1	1
	Q032021000	TORNILLO ALOMADO M4X10	CURVED SCREW M4X10	2	2	2	2

Зип Общепит

vsezip.ru

+7(812)987-08-81

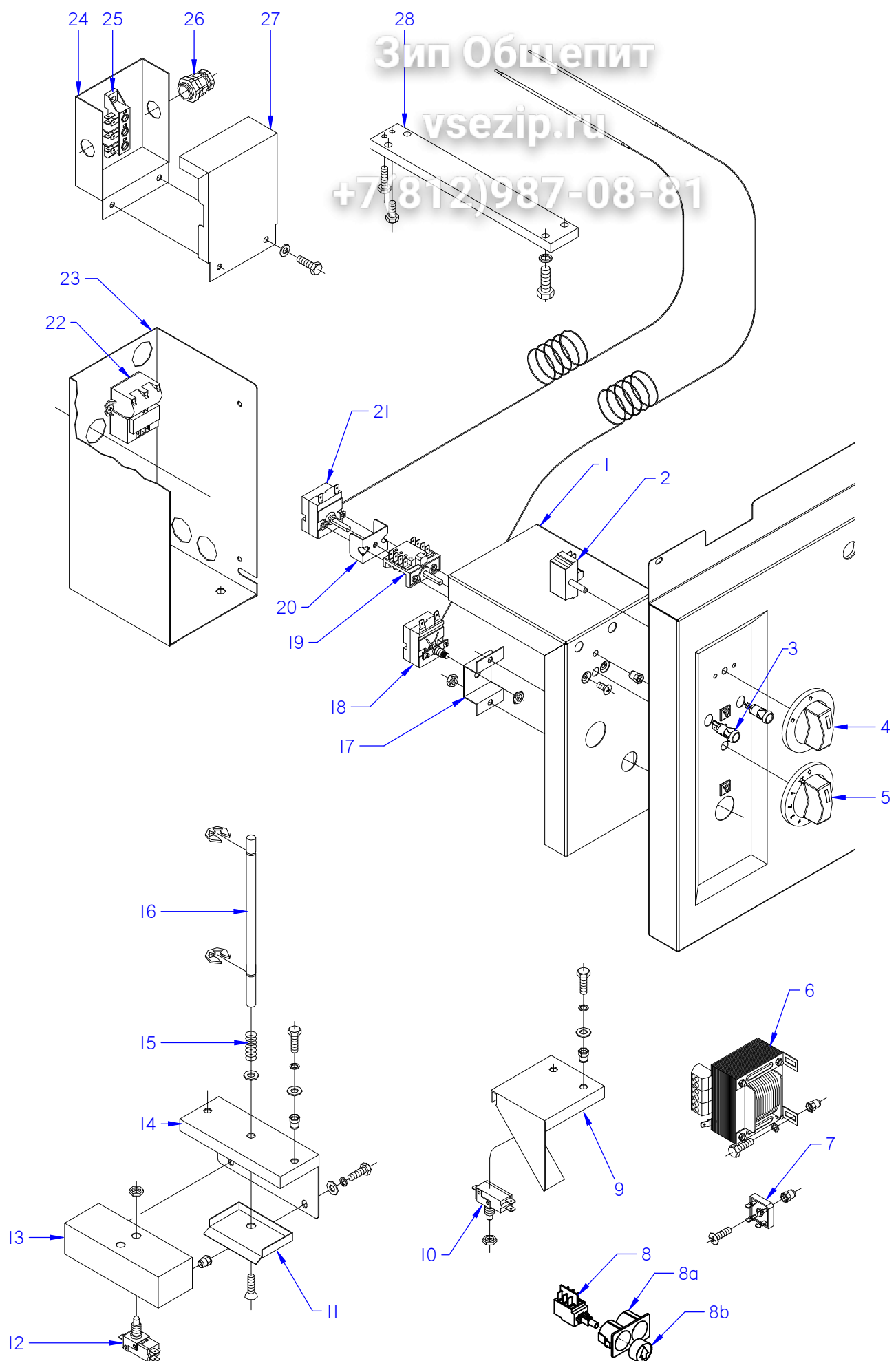

ITEM MARCADO EN COLOR = REPUESTO RECOMENDADO
COLOURED ITEM = RECOMMENDED SPARE PART

N plano	Firma	Fecha	Aparato	CONJUNTO FUNCIONAL ELECTRICO	Lamina	Fagor Industrial S.Coop. FAGOR
C-2184	<i>(Signature)</i>	2009-03	SARTEN BASCULANTE SBG		5	Oñate

MOD.	SARTEN BASCULANTE	ЗЧНА	CONJUNTO FUNCIONAL ELECTRICO
-------------	--------------------------	------	-------------------------------------

ITEM	CODIGO	DENOMINACION	TEXTO	SBG9-10 I	SBG9-10 I	SBG9-10 M	SBG9-10 IM	SBG9-15 IM
1	X152667000	TAPA CAJA SOPORTE VALVULA	VALVE SUPPORT BOX COVER	1	1	1	1	1
2	T343008000	CONMUTADOR HGC	HGC SWITCH	1	1	1	1	1
	Q151320000	TOR. ALOMADO M4X6 H.ZINCADO	CURVED SCREW M4X6 H. ZINC	2	2	2	2	2
3	X143017000	PILOTO VERDE SARTEN	GREEN FRYPAN PILOT	1	1	1	1	1
3	12047390	PILOTO VERDE 230V AC 8KW 16MM	GREEN PILOT 230V AC 8KW 16MM	1	1	1	1	1
	X143018000	PILOTO AMBAR SARTEN	FRYING PAM AMBER PILOT	1	1	1	1	1
	12024669	PILOTO AMBAR Ø18	AMBER PILOT Ø18	1	1	1	1	1
4	X022133000	BOTON DE MANDO Ø6 ENT. AGUA	CONTROL BUTTON Ø6 ENT. WAT	1	1	1	1	1
5	X022102000	BOTON DE MANDO SARTEN BASC.	CTRL BUTTON TILTING FRYPAN	1	1	1	1	1
6	X343021000	TRANSFORMADOR	TRANSFORMER	-	-	1	1	1
S/Nº	X342606000	CAJA TRANSFORMADOR	TRANSFORMER BOX	-	-	1	1	1
S/Nº	X342605000	TAPA TRANSFORMADOR	TRANSFORMER COVER	-	-	1	1	1
S/Nº	X342609000	ESCUJ. AMARRE TAPA TRANSFOR.	TRANSFORMER COVER FAST. SH	-	-	1	1	1
	Q012031000	TORNILLO EXAGONAL M5x10 A304	HEXAGONAL BOLT M5x10 A304	-	-	12	12	12
	Q302022000	ARANDELA 16x6x1,2 A304	WASHER 16x6x1.2 A304	-	-	9	9	9
	Q419005000	REMACHE 4x8 ALMG3 / ALUMINIO	RIVET 4X8 ALMG3 / ALUMINIUM	-	-	4	4	4
7	X343022000	PUENTE RECTIFICADOR FB 3502	RECTIFIER BRIDGE FB 3502	-	-	1	1	1
8	12024804	INTERRUPTOR PULSADOR	PRESS BUTTON SWITCH	-	-	2	2	2
8a	12009331	CUERPO PULSADOR	PRESS BUTTON BODY	-	-	1	1	1
8b	12009956	BOTON PULSADOR	PRESS BUTTON	-	-	2	2	2
S/Nº	12008786	PROTECTOR PULSADOR	PRESS BUTTON PROTECTOR	-	-	1	1	1
9	X342602000	SOPORTE MICRO	MICRO BRACKET	-	-	1	1	1
	Q221342000	REMACHE EXAGONAL M5	HEXAGONAL RIVET M5	-	-	2	2	2
	Q012031000	TORNILLO EXAGONAL M5x10 A304	HEXAGONAL BOLT M5x10 A304	-	-	2	2	2
	Q302022000	ARANDELA 16x6x1,2 A304	WASHER 16x6x1.2 A304	-	-	2	2	2
10	X343015000	MICRORRUPTOR 32280001	MICROSWITCH 32280001	-	-	2	2	2
10	12040850	MICRORRUPTOR 250V AC 16A VDE	MICROSWITCH 250V AC 16A VDE	-	-	2	2	2
	Q222005000	TUERCA EXAGONAL M10x0,75	HEXAGONAL NUT M10x0.75	-	-	2	2	4
11	X152646000	PROTECCION SUPERIOR	UPPER PROTECTION	1	1	1	1	1
	Q152024000	TORNILLO AVELLANADO M4x8 A304	COUNTERSUNK BOLT M4X8 A304	1	1	1	1	1

MOD.	SARTEN BASCULANTE	ZCNA	CONJUNTO FUNCIONAL ELECTRICO
-------------	--------------------------	------	-------------------------------------

ITEM	CODIGO	DENOMINACION	TEXTO	SBG9-10 I	SBG9-10 I	SBG9-10 M	SBG9-10 IM	SBG9-15 IM
12	X343015000	MICRORRUPTOR 32280001	MICROSWITCH 32280001	1	1	1	1	1
12	12040850	MICRORRUPTOR 250V AC16A VDE	MICROSWITCH 250V AC16A VDE	1	1	1	1	1
13	X152681000	CAJA PORTA MICRO	MICRO HOLDER BOX	1	1	1	1	1
	Q221342000	REMACHE EXAGONAL M5	HEXAGONAL RIVET M5	2	2	2	2	2
	Q012031000	TORNILLO EXAGONAL M5x10 A304	HEXAGONAL BOLT M5x10 A304	2	2	2	2	2
	Q302022000	ARANDELA 16x6x1,2 A304	WASHER 16x6x1.2 A304	2	2	2	2	2
	Q262030000	ARANDELA GROW. A5 A304	WASHER GROW. A5 A304	2	2	2	2	2
14	X152680000	SOPORTE CAJA PORTA MICRO	MICRO HOLDER BOX SUPPORT	1	1	1	1	1
	Q221342000	REMACHE EXAGONAL M5	HEXAGONAL RIVET M5	2	2	2	2	2
	Q012031000	TORNILLO EXAGONAL M5x10 A304	HEXAGONAL BOLT M5x10 A304	2	2	2	2	2
	Q302022000	ARANDELA 16x6x1,2 A304	WASHER 16x6x1.2 A304	2	2	2	2	2
	Q262030000	ARANDELA GROW. A5 A304	WASHER GROW. A5 A304	2	2	2	2	2
15	Z700603000	MUELLE 07777	SPRING 07777	1	1	1	1	1
16	X152682000	EJE PULSADOR MICRO	MICRO BUTTON SHAFT	1	1	1	1	1
	Q271033000	ARANDELA DE SEGURIDAD Ø6	SAFETY WASHER Ø6	2	2	2	2	2
17	X152661000	SOPORTE LIMITADOR	LIMITER SUPPORT	1	1	1	1	1
	Q162030000	TUERCA EXAGONAL M5	HEXAGONAL NUT M5	2	2	2	2	2
18	R612103000	TERMOSTATO LIMITADOR	THERMOSTAT LIMITER	1	1	1	1	1
	Q223022000	TUERCA EXAGONAL M8x1 LATON	HEXAGONAL NUT M8x1 BRASS.	1	1	1	1	1
	Q013023000	TORNILL. EXAGONAL M4x20 LATON	HEXAGONAL BOLT M4X20 BRASS	1	1	1	1	1
	Q163020000	TUERCA EXAGONAL M4 LATON	HEXAGONAL NUT M4 BRASS	1	1	1	1	1
	Q183001000	TUERCA CUADRADA M4	SQUARE NUT M4	1	1	1	1	1
	Q242020000	ARANDELA ABANICO A4 A304	FAN WASHER A4 A304	1	1	1	1	1
	Q563004000	LENGÜETA COMPONENTES DOBLE	DOUBLE COMPONENTS TONGUE	1	1	1	1	1
	Z603022000	PLACA ASIENTO CONEXIÓN MASA	SEATING PLATE EARTH CONNEC	1	1	1	1	1
19	X163007000	CONMUTADOR ACOUPLE TERMOS	THERMOSTAT CONNECT SWITCH	1	1	1	1	1
20	X313001000	"U" SOPORTE TERMOSTATO	THERMOSTAT U SUPPORT	1	1	1	1	1
21	X153000000	TERMOSTATO 50-310 C	THERMOSTAT 50-310 C	1	1	1	1	1
	Q042021000	TORNILL. AVELLANADO M4x10 A304	COUNTERSUNK BOLT M4X10 A30	2	2	2	2	2
22	X163014000	ENCENDEDOR 2 BUJIAS	LIGHTER 2 SPARK PLUG	1	1	1	1	1
	Q082005000	TORNILLO CHAP. 4,2X13 4.2X13	PLATE BOLT 4.2X13 4.2X13	2	2	2	2	2

Зип Ощепит

MOD.	SARTEN BASCULANTE	ZCNA	CONJUNTO FUNCIONAL ELECTRICO
-------------	--------------------------	------	-------------------------------------

vsezip.ru

+7(812)987-08-81

ITEM	CODIGO	DENOMINACION	TEXTO	SBG9-10	SBG9-10 I	SBG9-10 M	SBG9-10 IM	SBG9-15 IM
23	X152656000	SOPORTE VALVULA	VALVE SUPPORT	1	1	1	1	1
	Q411304000	REMACHE AVIBULB Ø 4,8	AVIBULB RIVET Ø 4.8	4	4	4	4	4
	Q221342000	REMACHE EXAGONAL M5	HEXAGONAL RIVET M5	2	2	2	2	2
24	X342601000	CUADRO REGLETA	STRIP PANEL	1	1	1	1	1
	Q221342000	REMACHE EXAGONAL M5	HEXAGONAL RIVET M5	2	2	2	2	2
	Q012042000	TORNILLO EXAGONAL M6x15	HEXAGONAL BOLT M6x15	2	2	2	2	2
	Q302022000	ARANDELA 16x6x1,2 A304	WASHER 16x6x1.2 A304	2	2	2	2	2
25	U183046000	REGLETA AUXILIAR	AUXILIARY STRIP	1	1	1	1	1
	Q152004000	TORN. APLASTADO M5x13 A304	HEXAGONAL FLAT SCREW M5x13	2	2	2	2	2
26	R073004000	PRENSA ESTOPAS	STUFFING BOX	2	2	2	2	2
	R073025000	CONTRATUERCA (GAES) 790.1300.0	COUNTERNUT (GAES) 790.1300.0	2	2	2	2	2
	R073026000	JUNTA DE GOMA (GAES)	RUBBER SEAL (GAES)	2	2	2	2	2
27	X342600000	TAPA CAJA REGLETA	STRIP BOX COVER	1	1	1	1	1
28	X156147000	CUBREBULBO	BULB COVER	1	—	1	—	—
	Q012043000	TORNILLO EXAGONAL M6x20 A304	HEXAGONAL BOLT M6x20 A304	4	—	4	—	—
	Q262040000	ARANDELA GROW. A6 A304	WASHER GROW. A6 A304	4	—	4	—	—
	Q012032000	TORNILLO EXAGONAL M5x15 A304	HEXAGONAL BOLT M5x15 A304	1	—	1	—	—
	Q012033000	TORNILLO EXAGONAL M5x20 A304	HEXAGONAL BOLT M5x20 A304	1	—	1	—	—

vsezip.ru

+7(812)987-08-81

MOD.		SARTEN BASCULANTE		ZONA	VARIOS (GAS)			
ITEM	CODIGO	DENOMINACION	TEXTO	SBG9-10	SBG9-10 S	SBG9-10 M	SBG9-15 MS	
	X026501000	FOLLETO DE INSTRUCC. SBG900	INSTRUCTION LEAFLET SBG900	1	1	1	1	
	X463002000	ESQUEMA TEORICO ADHESIVO	THEOR. DIAGRAM LABEL	1	1	1	1	
	X343023000	ESQUEMA TEORICO ADHESIVO	THEOR. DIAGRAM LABEL	1	1	1	1	
	X343023000	ESQUEMA TEORICO ADHESIVO	THEOR. DIAGRAM LABEL	1	1	1	1	
	X463004000	PLANO ELECT. DE MONTAJE SBG	ELECTRIC ASSEMBLY PLAN SBG	1	1	1	1	
	X463007000	LEYENDA SARTEN BASCULANTE	TILTING PAN LEGEND	1	1	1	1	
	X153021000	INSTALACION ELECTRICA	ELECTRIC INSTALLATION	1	1	1	1	
	X463003000	CABLEADO ELECTROV. SBG7-10	SOLENOID VALVE WIRING SBG7	1	1	1	1	
	X463005000	CABLEADO ELECTROV. SUSPEND.	SOLENOID VALVE WIRING SUSP	1	1	1	1	
	U333003000	CABLE MASA ENCENDEADOR	LIGHTER EARTH CABLE	1	1	1	1	
	U323007000	CABLE ENCENDEADOR A BUJIA	LIGHTER TO SPARK PLUG CABL	1	1	1	1	
	X163002000	CABLE BUJIA	SPARK PLUG CABLE	1	1	1	1	
	X283000000	CABLEADO MOTOR	MOTOR WIRING	1	1	1	1	

Зип Общепит

MOD. SARTEN BASCULANTE ZONA PIEZAS ESPECIFICAS PARA LOS DISTINTOS GAS

vsezip.ru

+7(812)987-08-81

ITEM	CODIGO	DENOMINACION	TEXTO	SBG9-10	SBG9-15				
		<u>BUTANO - PROPANO</u>	<u>BUTANE - PROPANE</u>						
6	U052401000	TOBERA Ø 1,45	NOZZLE Ø 1.45	2	3				
S/N	U136501000	INDICADOR (BUTANO-PROPANO)	INDICATOR (BUTANE-PROPANE)	1	1				
		<u>GAS NATURAL</u>	<u>NATURAL GAS</u>						
4	U442137000	INYECTOR Ø 0,40 GN	INJECTOR Ø 0.40 GN.	1	1				
6	U262400000	TOBERA Ø 2,15	NOZZLE Ø 2.15	2	-				
6	1011600000	TOBERA Ø 2,25	NOZZLE Ø 2.25	-	3				
S/N	U134402000	INDICADOR (GAS NATURAL)	INDICATOR (NATURAL GAS)	1	1				
		<u>GAS VILLA</u>	<u>TOWN GAS</u>						
6	X102403000	TOBERA Ø 4,58	NOZZLE Ø 4.58	2	-				
6	9145300000	TOBERA Ø 4.80	NOZZLE Ø 4.80	-	3				
S/N	U134310000	INDICADOR (GAS VILLA)	INDICATOR (TOWN GAS)	1	1				

Зип Общепит

MOD.	SARTEN BASCULANTE	vsezip.ru	REPUESTOS RECOMENDADOS RECOMMENDED SPARE PART
-------------	--------------------------	-----------	--

ITEM	CODIGO	DENOMINACION	TEXTO	SBG9-10 I	SBG9-10 M	SBG9-10 IM	SBG9-15 IM
7	S116121000	RESORTE TAPA 07199	SPRING COVER 07199	2	2	2	2
16	X156115000	CASQUILLO	BUSHING	1	1	-	-
10	X126114000	JUNTA UNIVERSAL 107A	UNIVERSAL JOINT 107A	-	-	1	1
15	X346107000	ACOPLAMIE. ELASTICO LOVEJOY	ELASTIC LOVEJOY COUPLING	-	-	1	1
17	X343020000	MOTORREDUCTOR (BOSCH)	GEAR MOTOR (BOSCH)	-	-	1	1
4	U322118000	PILOTO COMPLETO 100.062	COMPLETE PILOT LIGHT 100,062	1	1	1	1
10	U562130000	TERMOPAR L=850	THERMOCOUPLE L=850	1	1	1	1
13	X152121000	JUNTA VALVULA	VALVE GASKET	1	1	1	1
16	X153004000	CODO 1-2 820 NOV 906.260	L-PIPE 1-2 820 L-PIPE L-PIPE	2	2	2	2
18	12097292	VALVULA NOVA 820 REGULADA	VALVE REGULATED NOVA 820	1	1	1	2
18	12024777	ELECTROVALV. 820 NOVA 60 Hz.	SOLENOID VALVE. 820 NOVA 60	1	1	1	2
19	R275027000	CABLEADO ELECTROSIT 927.012	WIRING ELECTROSIT 927.012	1	1	1	1
22	Z701135000	E.V.SIMP.220V COD.255.208	E.V.SIMP.220V COD.255.208	1	1	1	1
2	T343008000	CONMUTADOR HGC	HGC SWITCH	1	1	1	1
3	12047390	PILOTO VERDE 230V AC 8KW 16MM	GREEN PILOT 230V AC 8KW 16M	1	1	1	1
	12024669	PILOTO AMBAR Ø18	AMBER PILOT Ø18	1	1	1	1
6	X343021000	TRANSFORMADOR	TRANSFORMER	-	-	1	1
7	X343022000	PUENTE RECTIFICADOR FB 3502	RECTIFIER BRIDGE FB 3502	-	-	1	1
8	12024804	INTERRUPTOR PULSADOR	PRESS BUTTON SWITCH	-	-	2	2
8a	12009331	CUERPO PULSADOR	PRESS BUTTON BODY	-	-	1	1
8b	12009956	BOTON PULSADOR	PRESS BUTTON	-	-	2	2
S/Nº	12008786	PROTECTOR PULSADOR	PRESS BUTTON PROTECTOR	-	-	1	1
10	12040850	MICRORRUPTOR 250V AC 16A VDE	MICROSWITCH 250V AC 16A VDE	-	-	2	2
12	12040850	MICRORRUPTOR 250V AC16A VDE	MICROSWITCH 250V AC16A VDE	1	1	1	1
18	R612103000	TERMOSTATO LIMITADOR	THERMOSTAT LIMITER	1	1	1	1
19	X163007000	CONMUTADOR ACOPLE TERMOS	THERMOSTAT CONNECT SWITC	1	1	1	1
21	X153000000	TERMOSTATO 50-310 C	THERMOSTAT 50-310 C	1	1	1	1
22	X163014000	ENCENDEDOR 2 BUJIAS	LIGHTER 2 SPARK PLUG	1	1	1	1

SBG7-10

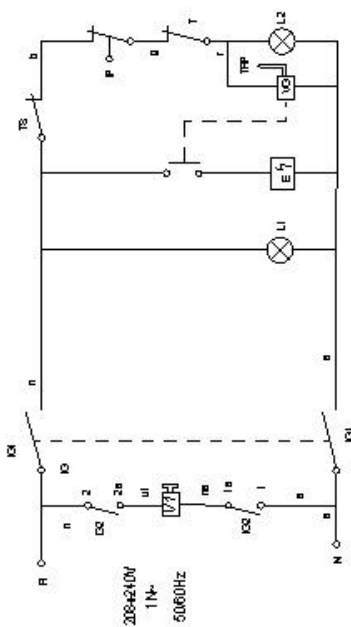

- r: negro
 - r: negro
 - r: rojo
 - b: blanco
 - g: gris
 - a: azul
- r: rojo
 - b: blanco
 - g: gris
 - a: azul
- r: negro
 - r: rojo
 - b: blanco
 - g: gris
 - a: azul
- r: rojo
 - b: blanco
 - g: gris
 - a: azul

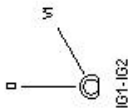

- E: Electrodominio
- IG: Interruptor general
- IP: Microseguridad
- L1: Lámpara marcha
- L2: Lámpara calefacción
- T: Termostato
- TS: Termostato seguridad
- TRP: Telemostrar
- VG: Válvula gas
- VI: Electroválvula

- E: Allimage
- IG: Interrupteur général
- IP: Micro sécurité
- L1: Veiluse marche
- L2: Veiluse chauffage
- T: Thermostat
- TS: Thermostat sécurité
- TRP: Telemostrar
- VG: Valve gaz

- E: Ignite r
- IG: Main switch
- IP: Security switch
- L1: O r light
- L2: Heating light
- T: Thermostat
- TS: Security thermostat
- TRP: Telemostrar
- VG: Gas valve

- E: Start
- IG: Hauptschalter
- IP: Mikro-Sicherheits
- L1: Funktionslicht
- L2: Erwärmungslicht
- T: Thermostat
- TS: Sicherheitsthermostat
- TRP: Telemostrar
- VG: Gasventil

- E: Ignite r
- IG: Interruptor general
- IP: Micro seguridad
- L1: Lámpara marcha
- L2: Lámpara calefacción
- T: Termostato
- TS: Termostato seguridad
- TRP: Telemostrar
- VG: Válvula gas

Esquema teórico SBG7-10		
Nº	Pieza	
Nº	Modificación	
Firma		Fecha
Dibujado		J. Etzeberri 29/11/2008
Proyectado		J. Etzeberri 29/11/2008
Comprobado		J. Etzeberri 29/11/2008
Escala		
4/5		SAR

SBG 910, 710, 915 M, 910 M

vsezip.ru

+7(812)987-08-81

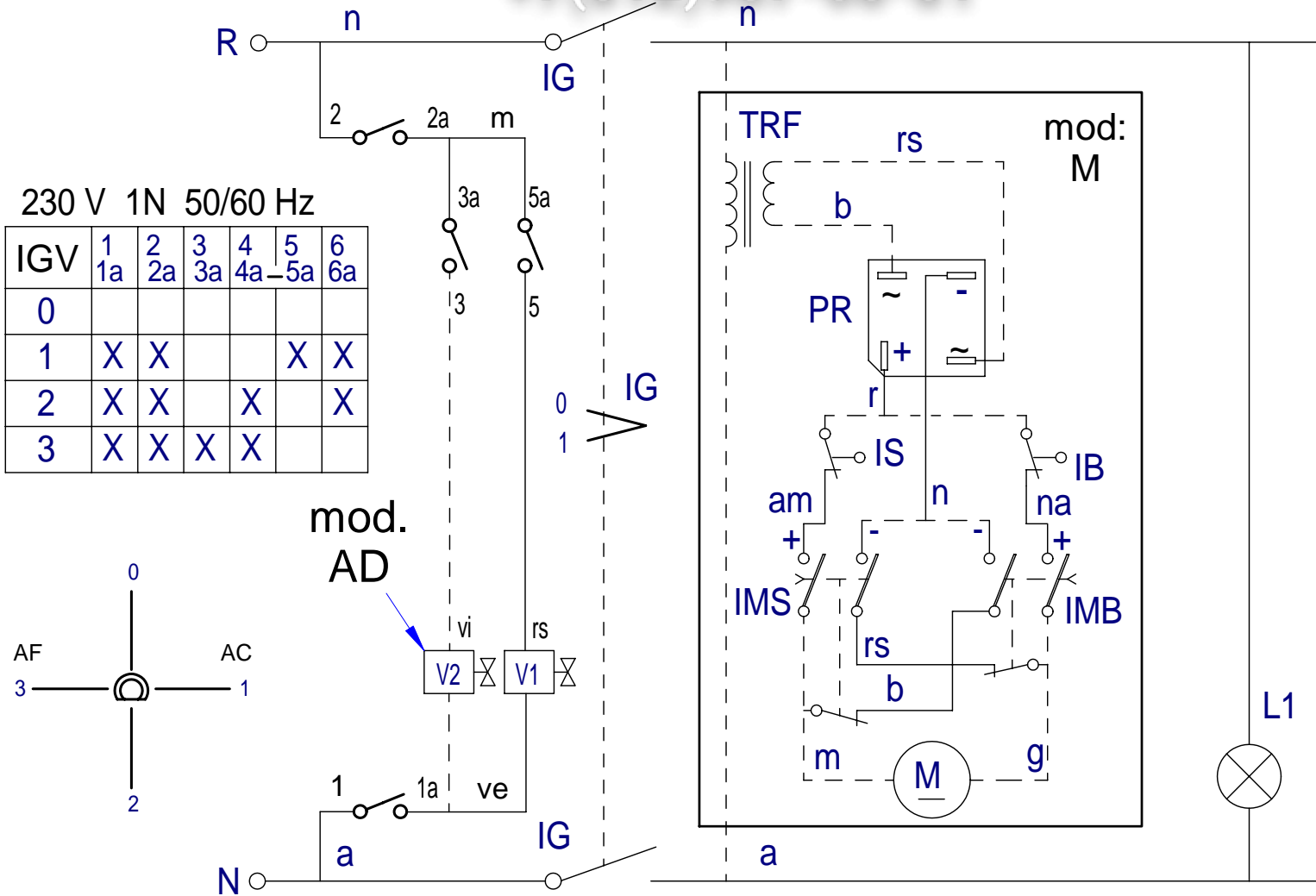

Simb/LENG		ESPAÑOL	ENGLISH	FRANÇAIS	DEUTSCH
C1, C2	=	Contactador Calentamiento	Contacteur Chauffe	Heating Contactor	Heizschütz
CN	=	Control de Nivel de agua	Control of water Level	Commanche de niveau d'eau	Steuerung des Wasserspi
E	=	Generador de Chispa	Spark generator	Générateur d'étincelle	Funkengenerator
IB	=	Micro tope bajada	Microswitch of lowered Limit	Microcontact de la limite abaissée	Mikroschalter der gesenkt
IG	=	Interruptor general	General switch	Commutateur général	Allgemeiner Schalter
IGV	=	Interruptor electrovalvulas de agua	Switch electrovalvula water	Commutez l'eau d'electrovalvula	Schalten Sie electrovalvula
IE	=	Pulsador de Encendido	Ignition Switch	Commutateur d'allumage	Zündung-Schalter
IMB	=	Pulsador bajada	lowered switch	commutateur abais	gesenkter Schalter
IMS	=	Pulsador subida	Raised switch	Commutateur augmenté	Angehobener Schalter
IP	=	Micro seguridad	security microswitch	microcontact de sécurité	Sicherheitsmikroschalter
IS	=	Micro tope subida	Microswitch of rise Limit	Microcontact de la limite d'élévation	Mikroschalter der Aufstieg
L1	=	Lámpara marcha	Operation Light	Lumière d'opération	Betriebs-Licht
L2	=	Lámpara calentamiento	Heating Light	Lumière de chauffage	Heizungs-Licht
M	=	Motor de elevacion	Motor of elevation	Moteur d'altitude	Motor des Aufzugs
P	=	Presostato de Camara	Water Level Switch	Commutateur de niveau d'eau	Wasserspiegel-Schalter
PR	=	Puente rectificador	Electrical bridge rectifier	Pont redresseur électrique	Elektrischer Brückengleich
R	=	Resistencia Calentamiento.	Resistance Chauffe	Heating Resistors	Widerstand Aufheizung
RE	=	Regulador Energia	Regulator of Energy	Régulateur d'énergie	Regler von Energie
T	=	Termostato	Thermostat	Thermostat	Thermostat
TRF	=	Transformador	Transformer	Transformateur	Transformator
TS	=	Termostato de seguridad	Security Thermostat	Thermostat de sécurité	Sicherheits-Thermostat
TRP	=	Termopar	Thermocouple	Thermocouple	Thermoelement
VG1,VG2	=	ElectroVálvula gas	Electrical gas valve	Clapet à gaz électrique	Elektrisches Gichtventil
V1	=	Valvula Agua CALIENTE	ElectroValve of Hot Water	Électrovalve d'eau chaude	Elektroventil des Heißwas
V2	=	Valvula Agua FRIA	ElectroValve of cold Water	Électrovalve d'eau froide	Elektroventil des kalten W
V3	=	Valvula Agua Caldera	electrovalve of water boiler	électrovalve de chauffe-eau	Elektroventil des Warmwa
	=	COLORES	COLOUR	COULEURS	FARBEN
a	=	Azul	Blue	Bleu	Blau
am	=	Amarillo	Yellow	Jaune	Gelb
am/ve	=	Amarillo/verde	Yellow / green	Jaune / vert	Gelb/grün
b	=	Blanco	White	Blanc	Weiß
g	=	Gris	Grey	Gris	Grau
m	=	Marrón	Brown	Marron	Braun
n	=	Negro	Black	Noir	Schwarz
na	=	Naranja	Orange	Orange	Orange
r	=	Rojo	Red	Rouge	Rot
rs	=	Rosa	Pink	Rose	Rosa
ve	=	Verde	Green	Vert	Grün
vi	=	Violeta	Purple	Violet	Violett

SBG 910, 710, 915 M, 910 M

vsezip.ru

+7(812)987-08-81

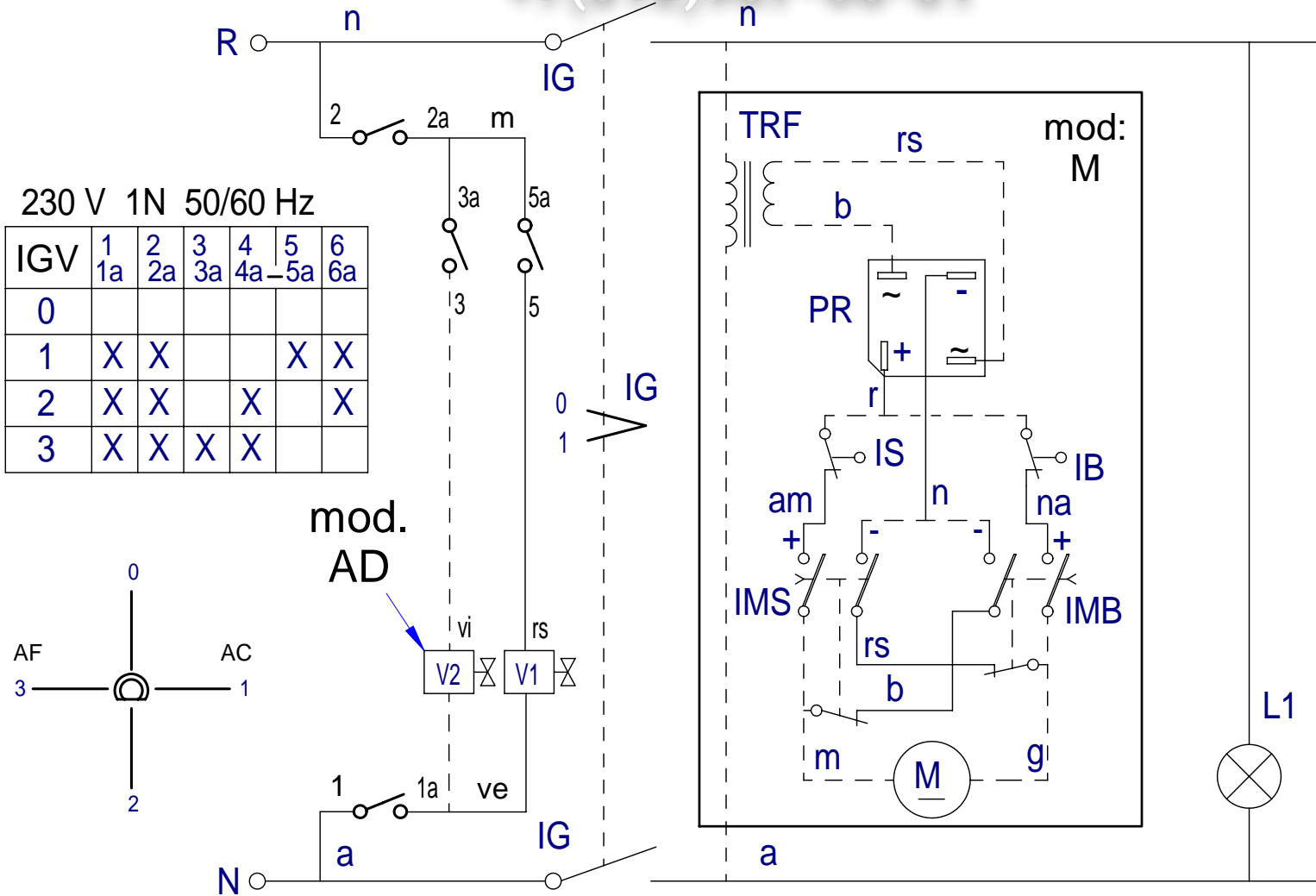

Simb/LENG		ESPAÑOL	ENGLISH	FRANÇAIS	DEUTSCH
C1, C2	=	Contactador Calentamiento	Contacteur Chauffe	Heating Contactor	Heizschütz
CN	=	Control de Nivel de agua	Control of water Level	Commanche de niveau d'eau	Steuerung des Wasserspi
E	=	Generador de Chispa	Spark generator	Générateur d'étincelle	Funkengenerator
IB	=	Micro tope bajada	Microswitch of lowered Limit	Microcontact de la limite abaissée	Mikroschalter der gesenkt
IG	=	Interruptor general	General switch	Commutateur général	Allgemeiner Schalter
IGV	=	Interruptor electrovalvulas de agua	Switch electrovalvula water	Commutateur l'eau d'electrovalvula	Schalten Sie electrovalvula
IE	=	Pulsador de Encendido	Ignition Switch	Commutateur d'allumage	Zündung-Schalter
IMB	=	Pulsador bajada	lowered switch	commutateur abais	gesenkter Schalter
IMS	=	Pulsador subida	Raised switch	Commutateur augmenté	Angehobener Schalter
IP	=	Micro seguridad	security microswitch	microcontact de sécurité	Sicherheitsmikroschalter
IS	=	Micro tope subida	Microswitch of rise Limit	Microcontact de la limite d'élévation	Mikroschalter der Aufstieg
L1	=	Lámpara marcha	Operation Light	Lumière d'opération	Betriebs-Licht
L2	=	Lámpara calentamiento	Heating Light	Lumière de chauffage	Heizungs-Licht
M	=	Motor de elevacion	Motor of elevation	Moteur d'altitude	Motor des Aufzugs
P	=	Presostato de Camara	Water Level Switch	Commutateur de niveau d'eau	Wasserspiegel-Schalter
PR	=	Puente rectificador	Electrical bridge rectifier	Pont redresseur électrique	Elektrischer Brückengleich
R	=	Resistencia Calentamiento.	Resistance Chauffe	Heating Resistors	Widerstand Aufheizung
RE	=	Regulador Energia	Regulator of Energy	Régulateur d'énergie	Regler von Energie
T	=	Termostato	Thermostat	Thermostat	Thermostat
TRF	=	Transformador	Transformer	Transformateur	Transformator
TS	=	Termostato de seguridad	Security Thermostat	Thermostat de sécurité	Sicherheits-Thermostat
TRP	=	Termopar	Thermocouple	Thermocouple	Thermoelement
VG1,VG2	=	ElectroVálvula gas	Electrical gas valve	Clapet à gaz électrique	Elektrisches Gichtventil
V1	=	Valvula Agua CALIENTE	ElectroValve of Hot Water	Électrovalve d'eau chaude	Elektroventil des Heißwas
V2	=	Valvula Agua FRIA	ElectroValve of cold Water	Électrovalve d'eau froide	Elektroventil des kalten W
V3	=	Valvula Agua Caldera	electrovalve of water boiler	électrovalve de chauffe-eau	Elektroventil des Warmwa
	=	COLORES	COLOUR	COULEURS	FARBEN
a	=	Azul	Blue	Bleu	Blau
am	=	Amarillo	Yellow	Jaune	Gelb
am/ve	=	Amarillo/verde	Yellow / green	Jaune / vert	Gelb/grün
b	=	Blanco	White	Blanc	Weiß
g	=	Gris	Grey	Gris	Grau
m	=	Marrón	Brown	Marron	Braun
n	=	Negro	Black	Noir	Schwarz
na	=	Naranja	Orange	Orange	Orange
r	=	Rojo	Red	Rouge	Rot
rs	=	Rosa	Pink	Rose	Rosa
ve	=	Verde	Green	Vert	Grün
vi	=	Violeta	Purple	Violet	Violett