

Зип Общепит

vsezip.ru

---

DESPIECE TECNICO

---

+7(812)987-08-81

**Cocina paellera a gas  
Gas ranges for paellas  
Fourneaux à gaz pour paellas  
Gas-herde für paellas  
Cucine a gas per paella  
Fogão a gás para paelhas**

**GAMA 900**

**Modelos:**

**CGP9-10**

**CGP9-11**

***Octubre 2006 October***

***Revisado Mayo 2014 May Revised***

**FAGOR** 

---

FAGOR INDUSTRIAL

Зип Общежит

vsezip.ru

+7(812)987-08-81

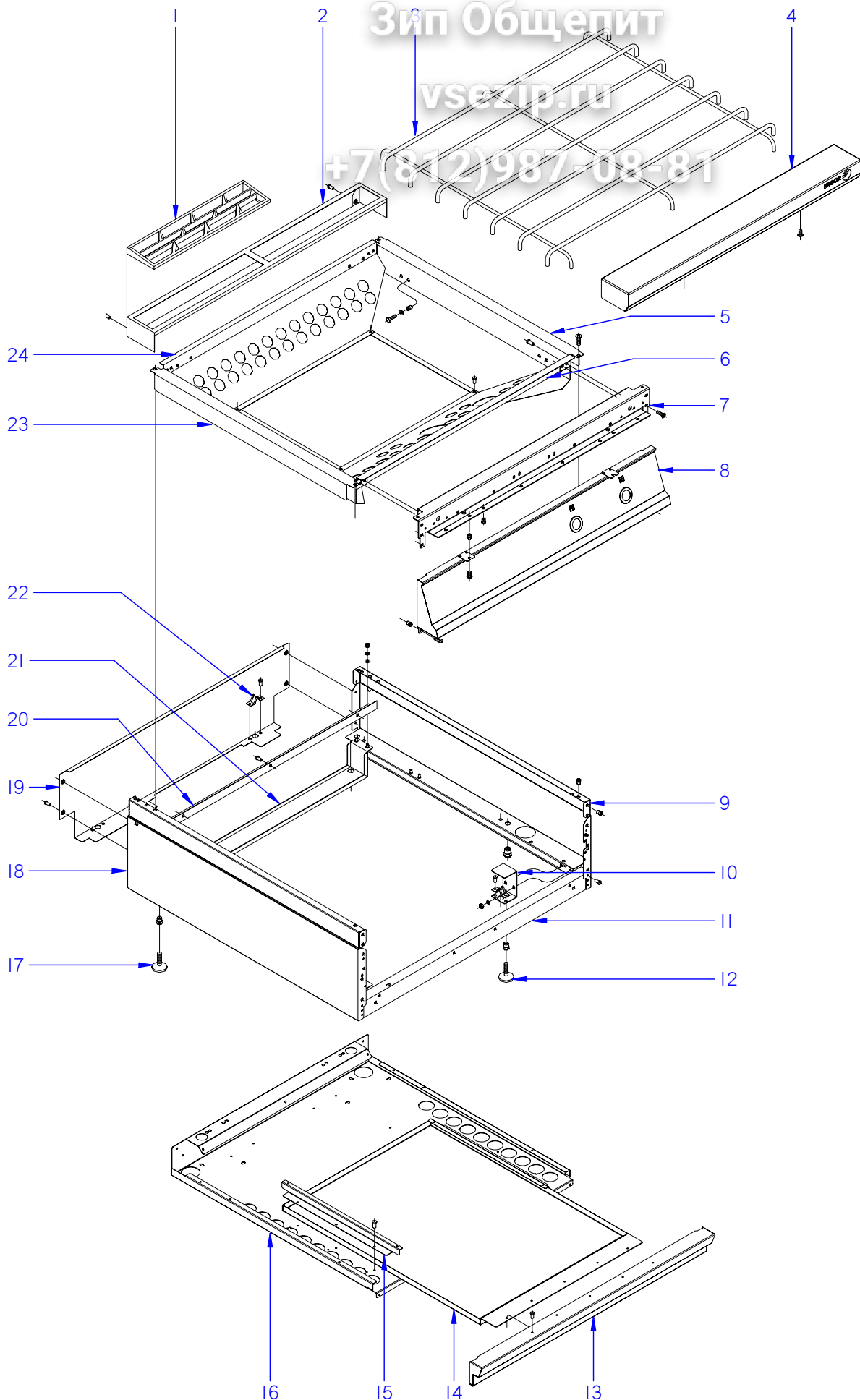

ITEM MARCADO EN COLOR = REPUESTO RECOMENDADO  
COLOURED ITEM = RECOMMENDED SPARE PART

N plano	Firma	Fecha	Aparato	MUEBLE	Lamina	Fagor Industrial S.Coop. <b>FAGOR</b>
C-1750	<i>(Signature)</i>	2006-10	COCINA PAELLERA CGP9-10		1	Oñate

MOD.		COCINAS		ZONA		MUEBLE	
ITEM	CODIGO	DENOMINACION	TEXTO	CGP9-10			
1	R205425000	EMBELLECEDOR ESMALTE	ENAMEL TRIM	2			
2	R205280000	SOPORTE EMBELLECEDOR 1 M	TRIM SUPPORT 1 M	1			
2	R205439000	SOPORTE EMBELLECEDOR 1 M	TRIM SUPPORT 1 M	1			
	Q419005000	REMACHE 4x8 ALMG3 / ALUMINIO	RIVET 4X8 ALMG3 / ALUMINIUM	2			
3	U875406000	PARRILLA SUPERIOR PAELLERA	SUPERIOR GRILL PAELLERO	1			
4	U025415000	ANTERIOR DE MESA 1 M	BENCH FRONT 1 M	1			
4	S105402000	ANTERIOR MESA 1 M	BENCH FRONT 1 M	1			
	Q152004000	TORNIL, APLASTADO M5x13 A304	FLAT HEADED BOLT M5x13 A304	2			
5	U875401000	LATERAL DECHO. MESA CGP9-10	RIGHT SIDE CGP9-10	1			
	Q221343000	REMACHE EXAGONAL M6	HEXAGONAL RIVET M6	8			
6	U875402000	ANTERIOR INTERIOR CGP9-10	FORMER INTERIOR CGP9-10	1			
7	U022605000	ESCUADRA INT. ANTERIOR MESA	TABLE SQUARE PREVIUOS HOM	1			
7	U022632000	ESCUADRA INT. ANTERIOR MESA	TABLE SQUARE PREVIUOS HOM	1			
8	U872809000	PORTAMANDOS CGP9-10	CONTROL HOLDER CG9-10	1			
8	U872816000	PORTAMANDOS COMPL. CGP9-10	CONTROL HOLDER CGP9-10	1			
	U022836000	ESCUDO FAGOR	FAGOR EMBLEM	1			
	Q221023000	CLIP SUJECIÓN RÁPIDA Ø5	RAPID CONNECT CLIP Ø5	2			
	Q152004000	TORNIL, APLASTADO M5x13 A304	FLAT HEADED BOLT M5x13 A304	2			
9	R062810000	PANEL LATERAL DERECHO G900	RIGHT SIDE PANEL G900	1			
	Q221342000	REMACHE EXAGONAL M5	HEXAGONAL RIVET M5	9			
	Q221343000	REMACHE EXAGONAL M6	HEXAGONAL RIVET M6	1			
10	H012805000	ESCUADRA AMARRE PATA	LEG FASTENING BRACKET	2			
	Q162030000	TUERCA EXAGONAL M5	HEXAGONAL NUT M5	4			
	Q302022000	ARANDELA 16x6x1,2 A304	WASHER 16x6x1.2 A304	4			
	Q221345000	REMACHE EXAGONAL M10	HEXAGONAL RIVET M10	2			
11	H022604000	LISTON AMARRE ZOCALO	ZOCALO TIE RIBBON	1			
	Q419005000	REMACHE 4x8 ALMG3 / ALUMINIO	RIVET 4X8 ALMG3 / ALUMINIUM	10			
12	Z201070000	PATA REGULABLE	LEG	2			
13	U872810000	ASA BANDEJA PAELLERO	ASA PAELLERO TRAY	1			
	Q419005000	REMACHE 4x8 ALMG3 / ALUMINIO	RIVET 4X8 ALMG3 / ALUMINIUM	3			
14	U872607000	BANDEJA RECOGEGRASAS SUPE.	GREASE COLLECTION TRAY	1			



Зип Общепит

vsezip.ru

+7(812)987-08-81

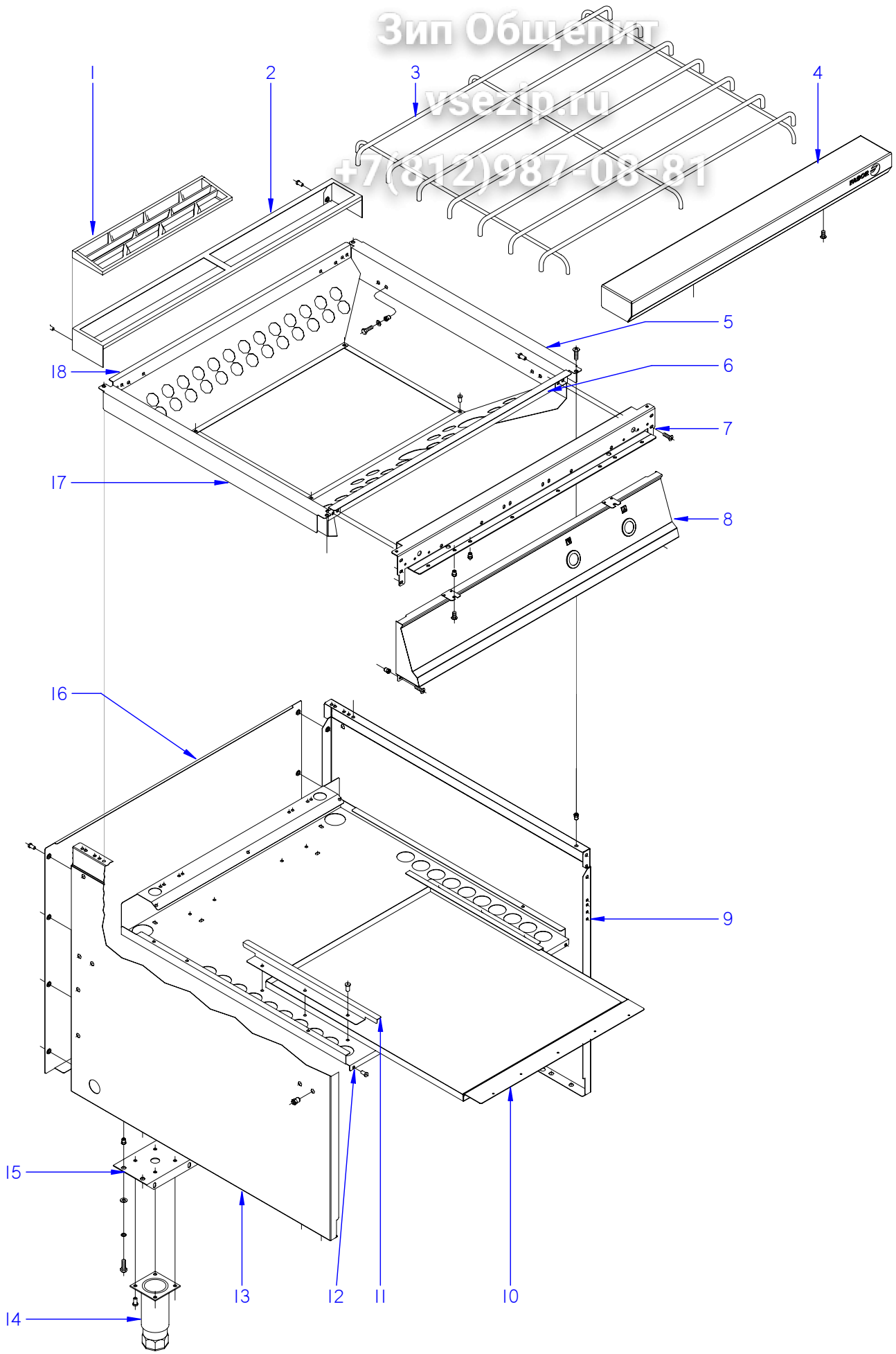

ITEM MARCADO EN COLOR = REPUESTO RECOMENDADO  
COLOURED ITEM = RECOMMENDED SPARE PART

N plano	Firma	Fecha	Aparato	MUEBLE	Lamina	Fagor Industrial S.Coop. <b>FAGOR</b>
C-1751	<i>(Signature)</i>	2006-10	COCINA PAELLERA CGP9-11		2	Oñate

MOD.	COCINAS	ZONA	MUEBLE					
ITEM	CODIGO	DENOMINACION	TEXTO	CGP9-11				
1	R205425000	EMBELLECEDOR ESMALTE	ENAMEL TRIM	2				
2	R205280000	SOPORTE EMBELLECEDOR 1 M	TRIM SUPPORT 1 M	1				
2	R205439000	SOPORTE EMBELLECEDOR 1 M	TRIM SUPPORT 1 M	1				
	Q419005000	REMACHE 4x8 ALMG3 / ALUMINIO	RIVET 4X8 ALMG3 / ALUMINIUM	2				
3	U875406000	PARRILLA SUPERIOR PAELLERA	SUPERIOR GRILL PAELLERO	1				
4	U025415000	ANTERIOR DE MESA 1 M	BENCH FRONT 1 M	1				
4	S105402000	ANTERIOR MESA 1 M	BENCH FRONT 1 M	1				
	Q152004000	TORNIL, APLASTADO M5x13 A304	FLAT HEADED BOLT M5x13 A304	2				
5	U875401000	LATERAL DECHO. MESA CGP9-10	RIGHT SIDE CGP9-10	1				
	Q221343000	REMACHE EXAGONAL M6	HEXAGONAL RIVET M6	8				
6	U875402000	ANTERIOR INTERIOR CGP9-10	FORMER INTERIOR CGP9-10	1				
7	U022605000	ESCUADRA INT. ANTERIOR MESA	TABLE SQUARE PREVIUOS HOM	1				
7	U022632000	ESCUADRA INT. ANTERIOR MESA	TABLE SQUARE PREVIUOS HOM	1				
8	U872812000	PORTAMANDOS CGP9-11	CONTROL HOLDER CGP9-11	1				
8	U872818000	PORTAMANDOS CGP9-11	CONTROL HOLDER CGP9-11	1				
	U022836000	ESCUDO FAGOR	FAGOR EMBLEM	1				
	Q221023000	CLIP SUJECIÓN RÁPIDA Ø5	RAPID CONNECT CLIP Ø5	2				
	Q152004000	TORNIL, APLASTADO M5x13 A304	FLAT HEADED BOLT M5x13 A304	2				
9	U022827000	PANEL LATERAL DERECHO	RIGHT SIDE PANEL	1				
	Q221343000	REMACHE EXAGONAL M6	HEXAGONAL RIVET M6	7				
	Q221342000	REMACHE EXAGONAL M5	HEXAGONAL RIVET M5	1				
	Q221342000	REMACHE EXAGONAL M5	HEXAGONAL RIVET M5	1				
	Q221343000	REMACHE EXAGONAL M6	HEXAGONAL RIVET M6	4				
	Q012043000	TORNILLO EXAGONAL M6x20 A304	HEXAGONAL BOLT M6x20 A304	4				
	Q302022000	ARANDELA 16x6x1,2 A304	WASHER 16x6x1.2 A304	4				
	Q221342000	REMACHE EXAGONAL M5	HEXAGONAL RIVET M5	3				
10	U872608000	BANDEJA RECOGEGRASAS SUPE.	GREASE COLLECTION TRAY	1				
10	12038813	BANDEJA RECOGEGRA. SUPE.MEK	GREASE COLLECTI. TRAY MEK	1				
11	U562640000	GUIA CENTRAL BANDEJAS	CENTRAL GUIDE TRAY	2				







MOD.	COCINAS	ZONA	PARTE FUNCIONAL GAS					
ITEM	CODIGO	DENOMINACION	TEXTO	CGP9-10				
1	Z982018000	BRIDA AMARRE GRIFO	TAP FASTENING FLANGE	2				
	Q151317000	TORNILLO EXAGONAL M5x22	HEXAGONAL BOLT M5x22	4				
2	U875019000	DISTRIBUIDOR COMPL. CGP9-10	COMPL. DISTRIBUTOR CGP9-10	1				
2	U875032000	DISTRIBUIDOR COMPL. CGP9-10	COMPL. DISTRIBUTOR CGP9-10	1				
	Q221342000	REMACHE EXAGONAL M5	HEXAGONAL RIVET M5	2				
	Q152004000	TORNIL, APLASTADO M5x13 A304	FLAT HEADED BOLT M5x13 A304	2				
3	U635008000	TUERCA CIEGA 3/4	BLIND NUT 3/4	2				
	Q306051000	ARANDELA TAPON Ø23,5x3	LID WASHER Ø23.5x3	2				
4	U875021000	CONDOC. GRIFO A QUEMADOR	BURNE PIPE	2				
4	U875035000	CONDOC. GRIFO A QUEMADOR	BURNE PIPE	2				
	Q153002000	TORNILLO TAPON	LID BOLT	2				
4a	U265033000	PORTATOBERAS Ø 10	NOZZLE HOLDER Ø 10	2				
5	R302400000	TOBERA Ø 1,65 BP	NOZZLE Ø 1,65 BP	1				QUE
5	X312400000	TOBERA Ø 1,10 BP	NOZZLE Ø 1,10 BP	1				QUE
5	U122407000	TOBERA Ø 1,05 BP	NOZZLE Ø 1,05 BP	1				QUE
5	U054400000	TOBERA Ø 2,50 GN	NOZZLE Ø 2,50 GN	1				QUE
5	910510000	TOBERA Ø 1,50 GN	NOZZLE Ø 1,50 GN	1				QUE
6	U875711000	CAMARA DE MEZCLA PAELLERA	MIXING CHAMBER PAELLERO	2				
	Q012032000	TORNILLO EXAGONAL M5x15 A304	HEXAGONAL BOLT M5x15 A304	2				
	Q223019000	TUERCA 3/8 GAS LATON	NUT 3/8 GAS BRASS	2				
7	U875714000	VENTURI QUEMADOR PAELLERO	VENTURI QUEMADOR	2				
	Q012032000	TORNILLO EXAGONAL M5x15 A304	HEXAGONAL BOLT M5x15 A304	2				
8	U875707000	QUEMADOR SUPERIOR COMPL.	TOP BURNER COMPLETE	1				
	Q221343000	REMACHE EXAGONAL M6	HEXAGONAL RIVET M6	8				
	Q221342000	REMACHE EXAGONAL M5	HEXAGONAL RIVET M5	4				
9	U875705000	SOPOR. PRINCIPAL QUEMADORES	MAIN BURNER SUPPORT.	2				
	Q221343000	REMACHE EXAGONAL M6	HEXAGONAL RIVET M16	8				
	Q012041000	TORNILLO EXAGONAL M6x10 A304	HEXAGONAL BOLT M6x10 A304	8				
	Q302022000	ARANDELA 16x6x1,2 A304	WASHER 16x6x1,2 A304	8				



Зип Общепит

vsezip.ru

+7(812)987-08-81

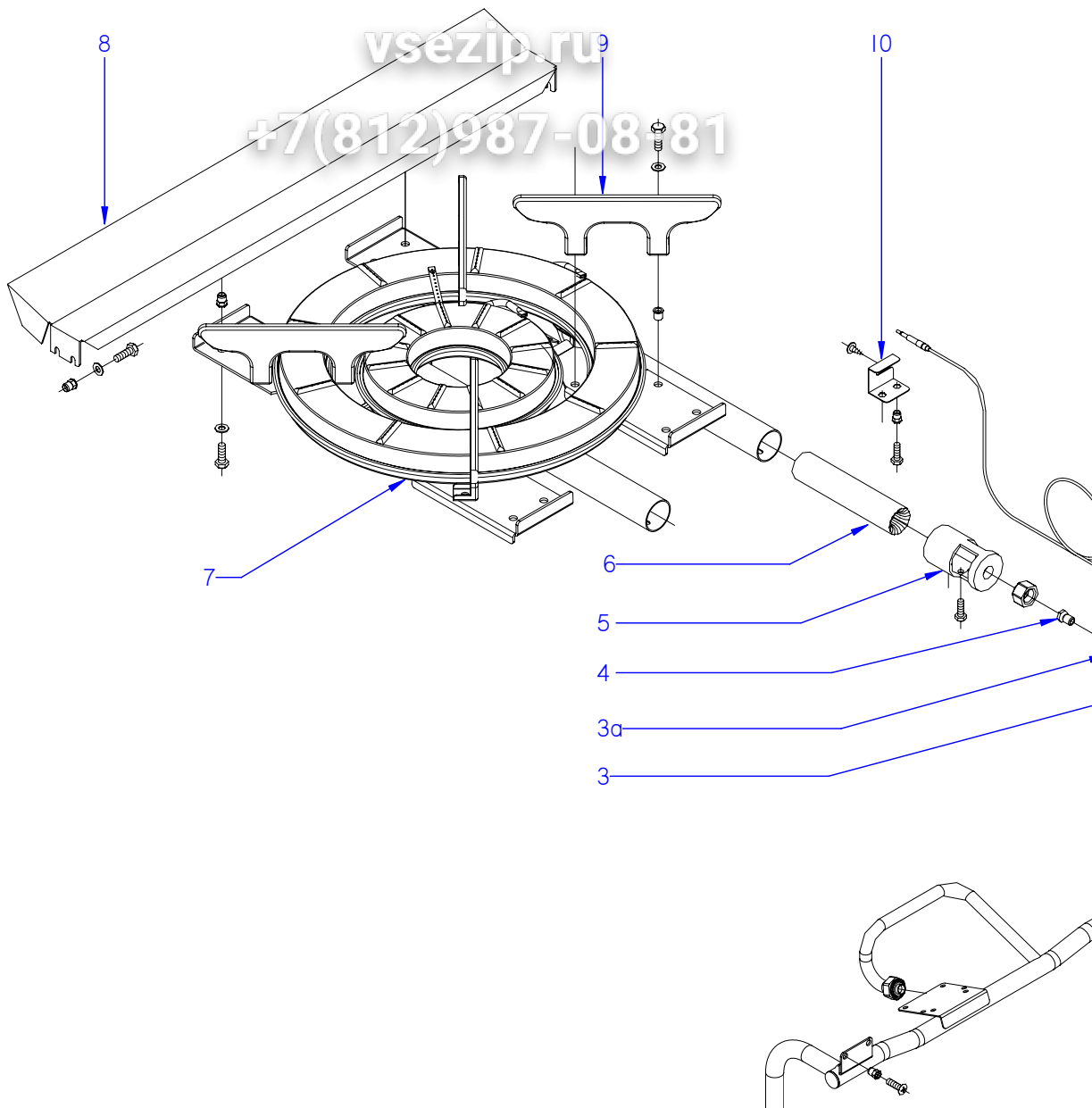

ITEM MARCADO EN COLOR = REPUESTO RECOMENDADO  
COLOURED ITEM = RECOMMENDED SPARE PART

N plano	Firma	Fecha	Aparato	Lamina	Fogor Industrial S. Coop.
C-1753	<i>(Firma)</i>	2006-10	COCINA PAELLERA CGP9-11	4	Onate
PARTE FUNCIONAL GAS MESA					
<b>FAGOR</b>					

MOD.	COCINAS	ZONA	PARTE FUNCIONAL GAS (MESA)				
ITEM	CODIGO	DENOMINACION	TEXTO	CGP9-11			
1	Z982018000	BRIDA AMARRE GRIFO	TAP FASTENING FLANGE	2			
	Q151317000	TORNILLO EXAGONAL M5x22	HEXAGONAL BOLT M5x22	4			
2	U875024000	DISTRIBUIDOR COMPL. CGP9-11	COMPL. DISTRIBUTOR CGP9-11	1			
2	U875039000	DISTRIBUIDOR COMPL. CGP9-11	COMPL. DISTRIBUTOR CGP9-11	1			
	Q221342000	REMACHE EXAGONAL M5	HEXAGONAL RIVET M5	2			
	Q152004000	TORNIL, APLASTADO M5x13 A304	FLAT HEADED BOLT M5x13 A304	2			
	Q152004000	TORNIL, APLASTADO M5x13 A304	FLAT HEADED BOLT M5x13 A304	3			
3	U875021000	CONduc. GRIFO A QUEMADOR	BURNE PIPE	2			
3	U875035000	CONduc. GRIFO A QUEMADOR	BURNE PIPE	2			
	Q153002000	TORNILLO TAPON	LID BOLT	2			
3a	U265033000	PORTATOVERAS Ø 10	NOZZLE HOLDER Ø 10	2			
4	R302400000	TOBERA Ø 1,65 BP	NOZZLE Ø 1,65 BP	1			
4	U122407000	TOBERA Ø 1,05 BP	NOZZLE Ø 1,05 BP	1			
4	U054400000	TOBERA Ø 2,50 GN	NOZZLE Ø 2,50 GN	1			
4	910510000	TOBERA Ø 1,50 GN	NOZZLE Ø 1,50 GN	1			
5	U875711000	CAMARA DE MEZCLA PAELLERA	MIXING CHAMBER PAELLERO	2			
	Q012032000	TORNILLO EXAGONAL M5x15 A304	HEXAGONAL BOLT M5x15 A304	2			
	Q223019000	TUERCA 3/8 GAS LATON	NUT 3/8 GAS BRASS	2			
6	U875714000	VENTURI QUEMADOR PAELLERO	VENTURI QUEMADOR	2			
	Q012032000	TORNILLO EXAGONAL M5x15 A304	HEXAGONAL BOLT M5x15 A304	2			
7	U875707000	QUEMADOR SUPERIOR COMPL.	TOP BURNER COMPLETE	1			
	Q221343000	REMACHE EXAGONAL M6	HEXAGONAL RIVET M6	8			
	Q221342000	REMACHE EXAGONAL M5	HEXAGONAL RIVET M5	4			
8	U875705000	SOPOR. PRINCIPAL QUEMADORES	MAIN BURNER SUPPORT.	2			
	Q221343000	REMACHE EXAGONAL M6	HEXAGONAL RIVET M16	8			
	Q012041000	TORNILLO EXAGONAL M6x10 A304	HEXAGONAL BOLT M6x10 A304	8			
	Q302022000	ARANDELA 16x6x1,2 A304	WASHER 16x6x1,2 A304	8			
9	U875704000	SOPORTE PAELLERO	PAELLERO SUPPORT	4			
	Q012041000	TORNILLO EXAGONAL M6x10 A304	HEXAGONAL BOLT M5x10 A304	8			
	Q302022000	ARANDELA 16x6x1,2 A304	WASHER 6x6x1,2 A304	8			



Зип Общепит

vsezip.ru

+7(812)987-08-81

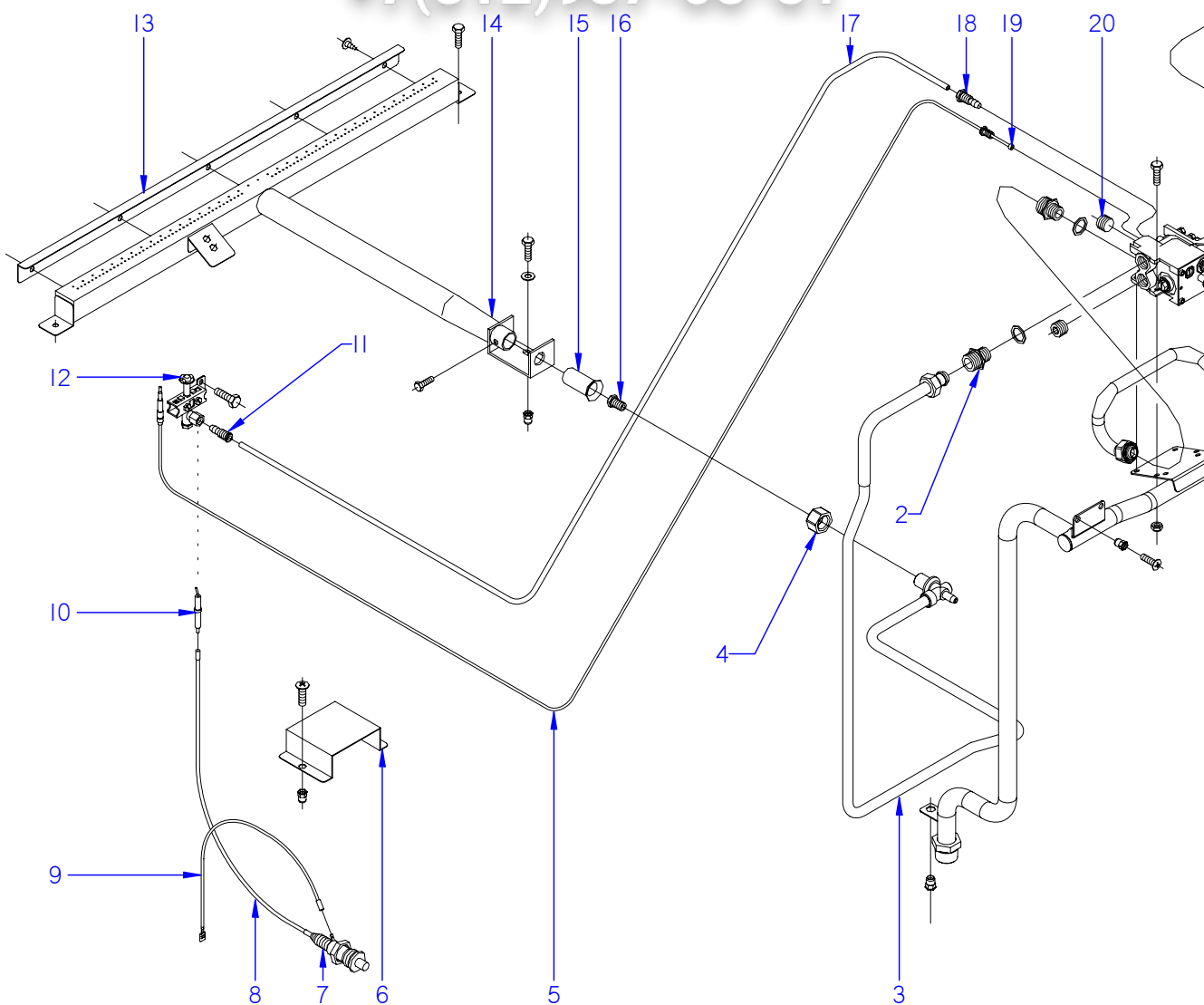

ITEM MARCADO EN COLOR = REPUESTO RECOMENDADO  
COLOURED ITEM = RECOMMENDED SPARE PART

N plano	Firma	Fecha	Aparato	Lamina	Fagor Industrial S. Coop.
C-1754	<i>(Signature)</i>	2006-10	COCINA PAELLERA CGP9-11	5	Onate
PARTE FUNCIONAL GAS HORNO					



MOD.	COCINAS	ZONA	PARTE FUNCIONAL GAS (HORNO)				
ITEM	CODIGO	DENOMINACION	TEXTO	CGP9-11			
1	U875024000	DISTRIBUIDOR COMPL. CGP9-11	COMPL. DISTRIBUTOR CGP9-11	1			
1	U875039000	DISTRIBUIDOR COMPL. CGP9-11	COMPL. DISTRIBUTOR CGP9-11	1			
	Q221343000	REMACHE EXAGONAL M6	HEXAGONAL RIVET M6	1			
	Q012031000	TORNILLO EXAGONAL M5x10 A304	HEXAGONAL BOLT M5X10 A304	2			
	Q162030000	TUERCA EXAGONAL M5	HEXAGONAL NUT M5	2			
	Q302022000	ARANDELA 16x6x1,2 A304	WASHER 16x6x1,2 A304	2			
2	U875017000	MANGUITO R /8"-R1/2"	HOSE R3/8"-R1/2"	2			
	Q306058000	ARANDELA 23,5x17,6x1,5	WASHER 23,5x17,6x1,5	2			
3	U875029000	CONDUCCION HORNO CGP9-11	OVEN DRIVE CGP9-11	1			
3	U875042000	CONDUCCION HORNO CGP9-11	OVEN DRIVE CGP9-11	1			
4	U565011000	TUERCA GUIA 3/8"	NUT GUIDE 3/8"	1			
5	U742131000	TERMOPAR L=1500 M9	THERMOCOUPLE L=1500 M9	1			
6	U062604000	CAJA PROTECCION PIEZOELECT.	PIEZOELECT. PROTECTION BOX	1			
	Q152004000	TORNIL, APLASTADO M5x13 A304	FLAT HEADED BOLT M5x13 A304	2			
7	S113034000	PIEZOELECTRICO	PIEZOELECTRIC	1			
7	12043897	PIEZOELECTRICO COMPLETO	COMPLETE PIEZOELECTRIC	1			
S/Nº	12043907	ANILLO ADAPTADOR	ADAPTER RING	1			
8	U323030000	CABLE BUJIA	SPARK PLUG CABLE	1			
9	U333003000	CABLE MASA ENCENDEDOR	LIGHTER EARTH CABLE	1			
10	X022131000	BUJIA	SPARK PLUG	1			
11	U134323000	RACORD BICONO Ø6 958.031	BICONE CONNECTION Ø6 958.03	2			
12	U322118000	PILOTO COMPLETO 100.062	COMPLETE PILOT LIGHT 100,062	1			
	U442138000	INYECTOR Ø 0,25 BP Y GV	INJECTOR Ø0,25 BP Y GV	1			
	U442137000	INYECTOR Ø 0,4 GN	INJECTOR Ø 0.4 GN.	1			
	Q012031000	TORNILLO EXAGONAL M5x15 A304	HEXAGONAL BOLT M5X15 A304	2			
13	U065703000	CHAPA LLAMA PILOTO	PILOT PLATE	1			
	Q151301000	PHILIPS 8x5/8	PHILIPS 8x5/8	5			
	Q152004000	TORNIL, APLASTADO M5x13 A304	FLAT HEADED BOLT M5x13 A304	3			
14	U875701000	QUEMADOR HORNO PAELLERO	OVEN BURNER	1			
15	U325707000	REGULADOR DE AIRE	AIR CONTROL	1			
	Q012031000	TORNILLO EXAGONAL M5x10 A304	HEXAGONAL BOLTM5x10 A304	1			

MOD.	COCINAS		ZONA	PARTE FUNCIONAL GAS (HORNO)			
ITEM	CODIGO	DENOMINACION	TEXTO	CGP9-11			
16	R612400000	TOBERA Ø 1,35 BP	NOZZLE Ø 1,35 BP	1			
16	U264000000	TOBERA Ø 2,15 GN	NOZZLE Ø 2,15 BP	1			
17	U875031000	TUBO PILOTO HORNO CGP9-11	PILOT PIPE BURNER	1			
17	U875045000	TUBO PILOTO HORNO CGP9-11	PILOT PIPE BURNER	1			
18	U134323000	RACORD BICONO 6 958.031	BICONE CONNECTION 6 958.031	2			
19	U264301000	RACORD EMPALME TERMOPAR	THERMOC. JUNCTION RACORD	1			
20	T982102000	TAPON 3/8 972.061	LID 3/8 972.061	2			
21	U055644000	CONJUNTO FIJACION BULBO	FIJACION BULB SET	1			
	Q419005000	REMACHE 4x8 ALMG3 / ALUMINIO	RIVET 4X8 ALMG3 / ALUMINIUM	2			
22	T982100000	VALVULA 630 EUR 630.343	VALVE 630 EUR 630.343	1			
22	R152102000	VALVULA 630 EUR 630.345	VALVE 630 EUR 630.345	1			
23	R062102000	EJE BOTON MANDO EUROSIT META	CTRL. BUTTN. SHAFT EUROSIT M	1			
	Q131502000	VARILLA ROSCADA 5x6	THREADED ROD 5x6	3			
24	R042102000	BOTON DE MANDO FTG EUR	CONTROL BUTTON FTG EUR	1			



Зип Общепит

vsezip.ru

+7(812)987-08-81

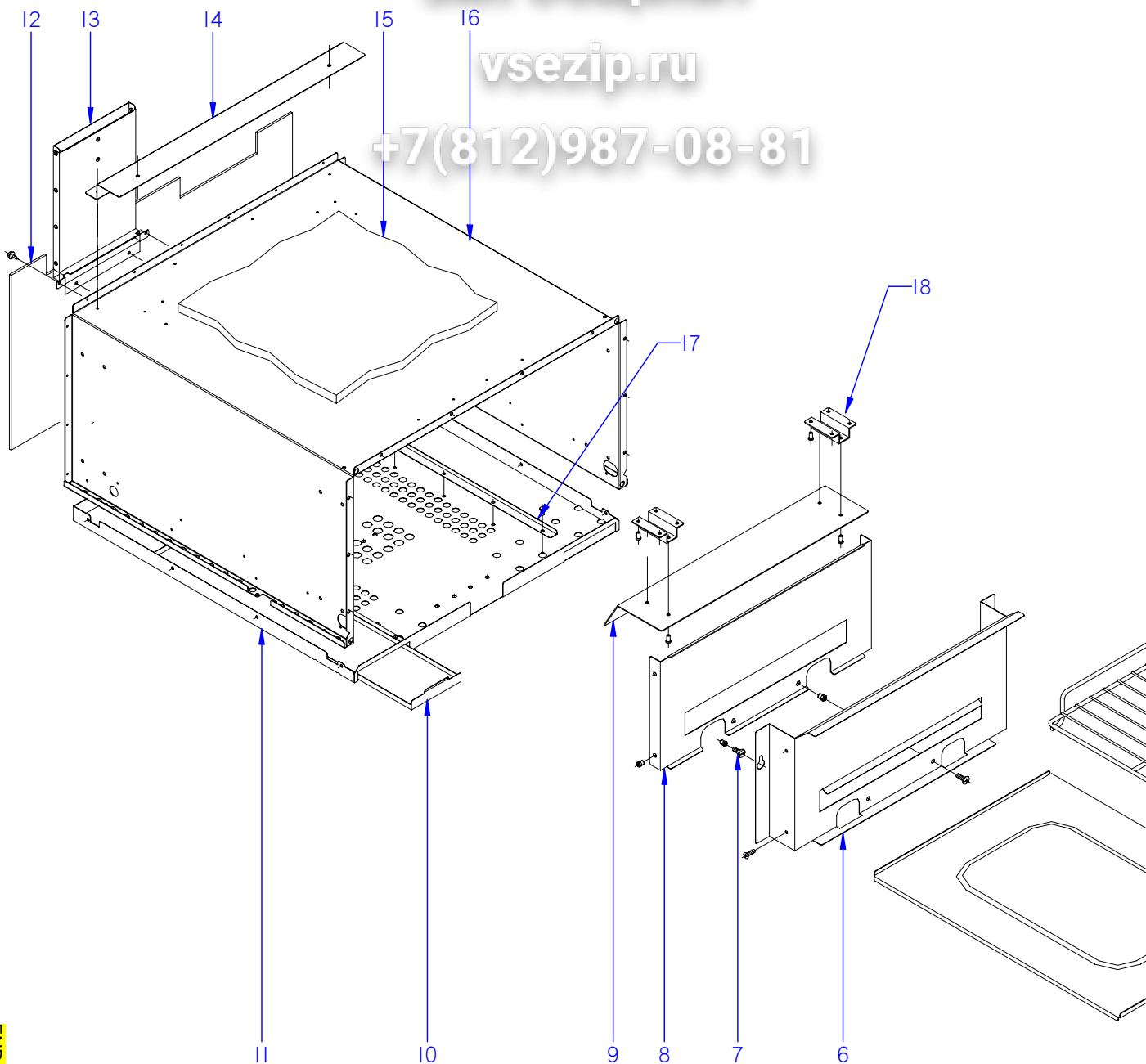

ITEM MARCADO EN COLOR = REPRESENTO RECOMENDADO  
COLOURED ITEM = RECOMMENDED SPARE PART

N plano	C-1755
Firma	www.fagor.com
Fecha	2006-10
Aparato	COCINA PAELLERA CGP9-11
HORNO	
Lamina	6
Fagor Industrial S. Coop. <b>FAGOR</b> 	
Orte	

+7(812)987-08-81

MOD.		COCINAS		ZONA		HORNO			
ITEM	CODIGO	DENOMINACION	TEXTO	CGP9-11					
1	U065613000	ESCUADRA SOP. LAT. PARRILLAS	SHELF BRACKET SUPPORT SIDE	8					
	Q152004000	TORNIL, APLASTADO M5x13 A304	FLAT HEADED BOLT M5x13 A304	16					
2	U875616000	SOPORTE LATERAL PARRILLAS	GRILL SIDE SUPPORT	2					
3	U875619000	TEJADILLO LATERAL PAELLERO	SIDE ROOF PAELLERO	2					
	Q419005000	REMACHE 4x8 ALMG3 / ALUMINIO	RIVET 4X8 ALMG3 / ALUMINIUM	8					
4	U875617000	PARRILLA COMPLETA PAELLERO	FULL GRILL PAELLERO	1					
5	U875614000	SOLERA DE HORNO PAELLERO	PAELLERO HEARTH FURNACE	1					
5	U875638000	SOLERA DE HORNO PAELLERO	PAELLERO HEARTH FURNACE	1					
6	U875613000	CHAPA FRONTAL INT. PAELLERO	INTE. FRONT PLATE PAELLERO	1					
6	U875637000	CHAPA FRONTAL INT. PAELLERO	INTE. FRONT PLATE PAELLERO	1					
	Q221342000	REMACHE EXAGONAL M5	HEXAGONAL RIVET M5	4					
	Q221343000	REMACHE EXAGONAL M6	HEXAGONAL RIVET M6	2					
7	R252624000	PITON SOPORTE	PITON SUPPORT	2					
8	U875615000	PROTECTOR DE HUMOS HORNO	PROTECTOR SMOKE OVEN	1					
	Q152004000	TORNIL, APLASTADO M5x13 A304	FLAT HEADED BOLT M5x13 A304	4					
	Q152017000	TORNIL, AMARRE M6x13 A304	CLAMPING SCREW M6x13 A304	2					
9	U065609000	CONDUC. DE HUMOS SUPERIOR	TOP DRIVE SMOKE	1					
	Q419005000	REMACHE 4x8 ALMG3 / ALUMINIO	RIVET 4X8 ALMG3 / ALUMINIUM	4					
10	U875620000	RECOGEGRASAS HORNO PAELL.	OVEN COLLECTOR UNDER PAE.	2					
11	U875602000	BASE DE HORNO PAELLERO	OVEN BASE	1					
	Q419005000	REMACHE 4x8 ALMG3 / ALUMINIO	RIVET 4X8 ALMG3 / ALUMINIUM	10					
	Q221342000	REMACHE EXAGONAL M5	HEXAGONAL RIVET M5	3					
12	U875626000	AISLANTE POSTERIOR HORNO	INSULATION OVEN BACK	2					
13	U875622000	POSTERIOR CHIMENEA PAELLER.	FIRE BACK PAELLER.	2					
	Q419005000	REMACHE 4x8 ALMG3 / ALUMINIO	RIVET 4X8 ALMG3 / ALUMINIUM	16					
	Q419005000	REMACHE 4x8 ALMG3 / ALUMINIO	RIVET 4X8 ALMG3 / ALUMINIUM	6					
14	U875604000	ESCUA. AMARRE BASE BANDEJAS	CLAMPING BRACKET BASE TRA.	1					
	Q221342000	REMACHE EXAGONAL M5	HEXAGONAL RIVET M5	4					



Зип Общепит

vsezip.ru

+7(812)987-08-81

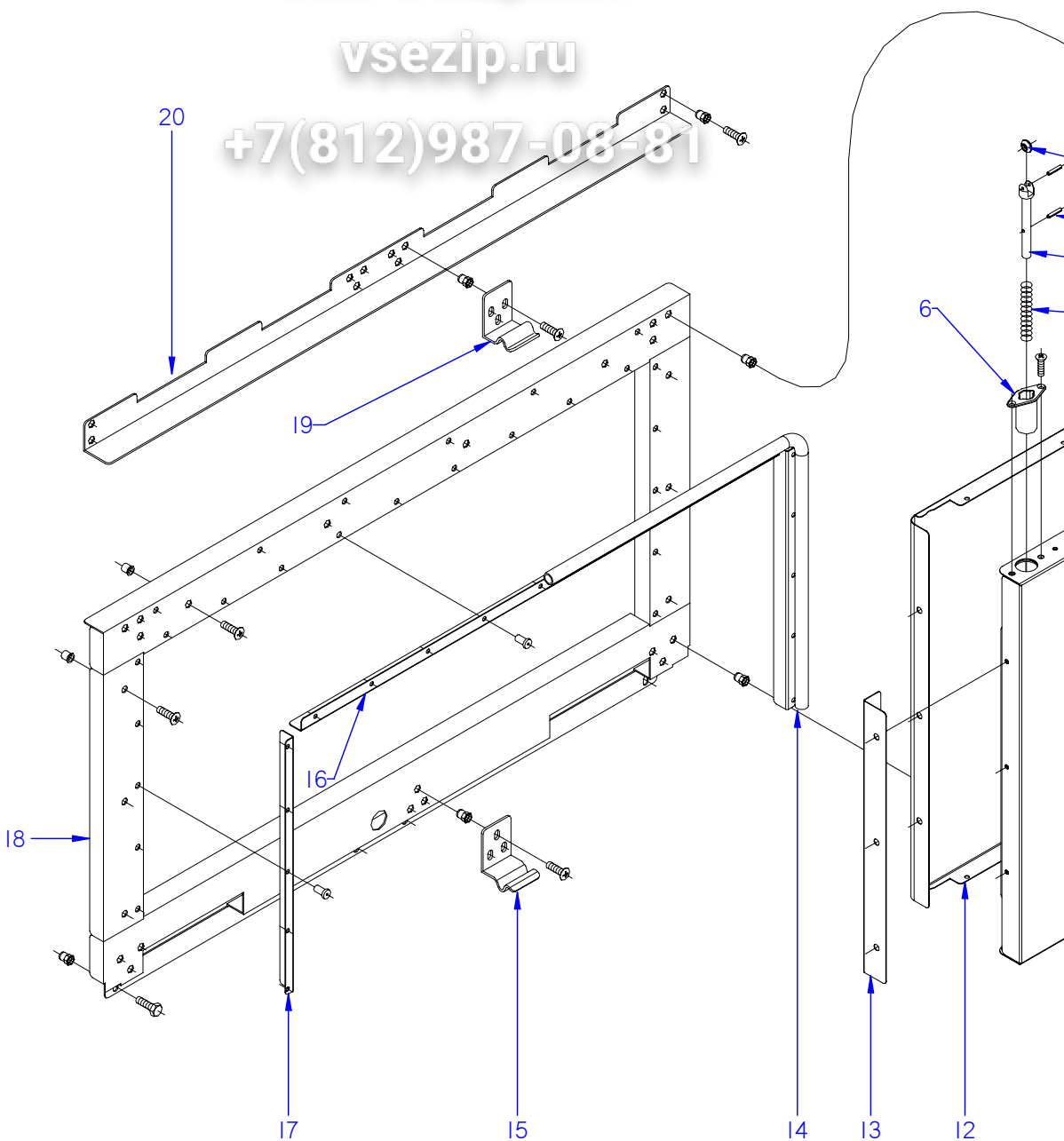

ITEM MARCADO EN COLOR = REPUESTO RECOMENDADO  
COLOURED ITEM = RECOMMENDED SPARE PART

N plano	C-1756
Firma	<i>(Signature)</i>
Fecha	2006-10
Aparato	MARCO Y PUERTA DE HORNO COCINA PAELLERA CGP9-11
Lamina	7
Order	Fagor Industrial S. Coop. <b>FAGOR</b>

# Зип Общепит

vsezip.ru

ZONA

MARCO Y PUERTAS DE HORNO

MOD.	COCINAS							
ITEM	CODIGO	DENOMINACION	TEXTO	CGP9-11				
1	U870512000	BISAGRA SUPERIOR DERECHA	UPPER RIGHT HINGE	1				
S/N	U870513000	BISAGRA SUPERIOR IZQUIERDA	UPPER LEFT HINGE	1				
	Q152004000	TORNIL, APLASTADO M5x13 A304	FLAT HEADED BOLT M5x13 A304	3				
	Q152004000	TORNIL, APLASTADO M5x13 A304	FLAT HEADED BOLT M5x13 A304	3				
2	U060527000	RODILLO FIJACION PUERTA	FIXING ROLLER DOOR	2				
3	Q371030000	RESORTE ELASTICO 3x18	3x18 ELASTIC SPRING	4				
4	U060544000	EJE ENGANCHE RODILLO	ROLLER AXLE ATTACHMENT	2				
5	U060541000	MUELLE	SPRING	2				
6	U060543000	CUERPO BLOQUEO RODILLO	ROLLER LOCK BODY	2				
	Q042021000	TORNIL, AVELLANADO M4x10 A304	COUNTERSUNK BOLT M4x10	4				
7	U020507000	ASA DE ARMARIO COMPLETA	FULL CUPBOARD HANDLE	2				
	Q162040000	TUERCA EXAGONAL M6	HEXAGONAL NUT M6	4				
	Q302022000	ARANDELA 16x6x1,2 A304	WASHER 16x6x1.2 A304	4				
8	1100003310	PUERTA DCHA. PAELLERO COMP.	RIGHT DOOR PAELLERO	1				
S/N	1100003311	PUERTA IZDA. PAELLERO COMPL.	LEFT DOOR PAELLERO	1				
	Q232040000	ARANDELA PLANA A6	FLAT WASHER A6	4				
9	Q152004000	TORNIL, APLASTADO M5x13 A304	FLAT HEADED BOLT M5x13 A304	6				
	Q232050000	ARANDELA PLANA A8	FLAT WASHER A8	2				
10	X960504000	TORNILLO DE GIRO M8	ROTATION BOLT M8	2				
11	U060525000	BISAGRA INFERIOR	LOWER HINGE	2				
12	U870502000	CONTRAPUERTA DERECHA	RIGHT DOOR REVERSE	1				
S/N	U870508000	CONTRAPUERTA IZQUIERDA	LEFT DOOR REVERSE	1				
	Q412000000	REMACHE TUBULAR 4x8	TUBULAR RIVET 4x8	9				
	Q412000000	REMACHE TUBULAR 4x8	TUBULAR RIVET 4x8	9				
13	U870509000	ESCUADRA APERTURA PUERTA	DOOR OPENING ANGLE	1				
	Q152004000	TORNIL, APLASTADO M5x13 A304	FLAT HEADED BOLT M5x13 A304	6				
14	U875632000	JUNTA COMPLETA DE HORNO	OVEN DOOR SEAL	1				
15	U060540000	ESCUADRA FIJ. INFERIOR PUERTA	DOOR BOTTOM BRACKET FIXI.	1				
	Q152004000	TORNIL, APLASTADO M5x13 A304	FLAT HEADED BOLT M5x13 A304	6				
16	U875628000	AMARRE HORIZONTAL JUNTA	HORIZONTAL CLAMPING BOARD	1				
17	U875629000	VERTICAL AMARRE JUNTA	VERTICAL CLAMPING BOARD	2				





