

Зип Общепит

vsezip.ru

---

DESPIECE TECNICO / SPARE PARTS BOM

---

+7(812)987-08-81

**Cocinas a Gas**  
**Gas ranges**  
**Fourneaux à gaz**  
**Gas-herde**  
**Cucine a gas**  
**Fogão a gás**

**GAMA 900 RANGE**

**Modelos / Models:**

**CG9-20**

**CG9-40**

**CG9-60**

**CG9-41**

**CG9-61**

**CG9-82**

**CGE9-41**

**CG9-61 OP**

***Junio 2009 June***

***Revisado Febrero 2016 February Revised***

**FAGOR** 

---

F A G O R I N D U S T R I A L

Зип Общепит

vsezip.ru

+7(812)987-08-81

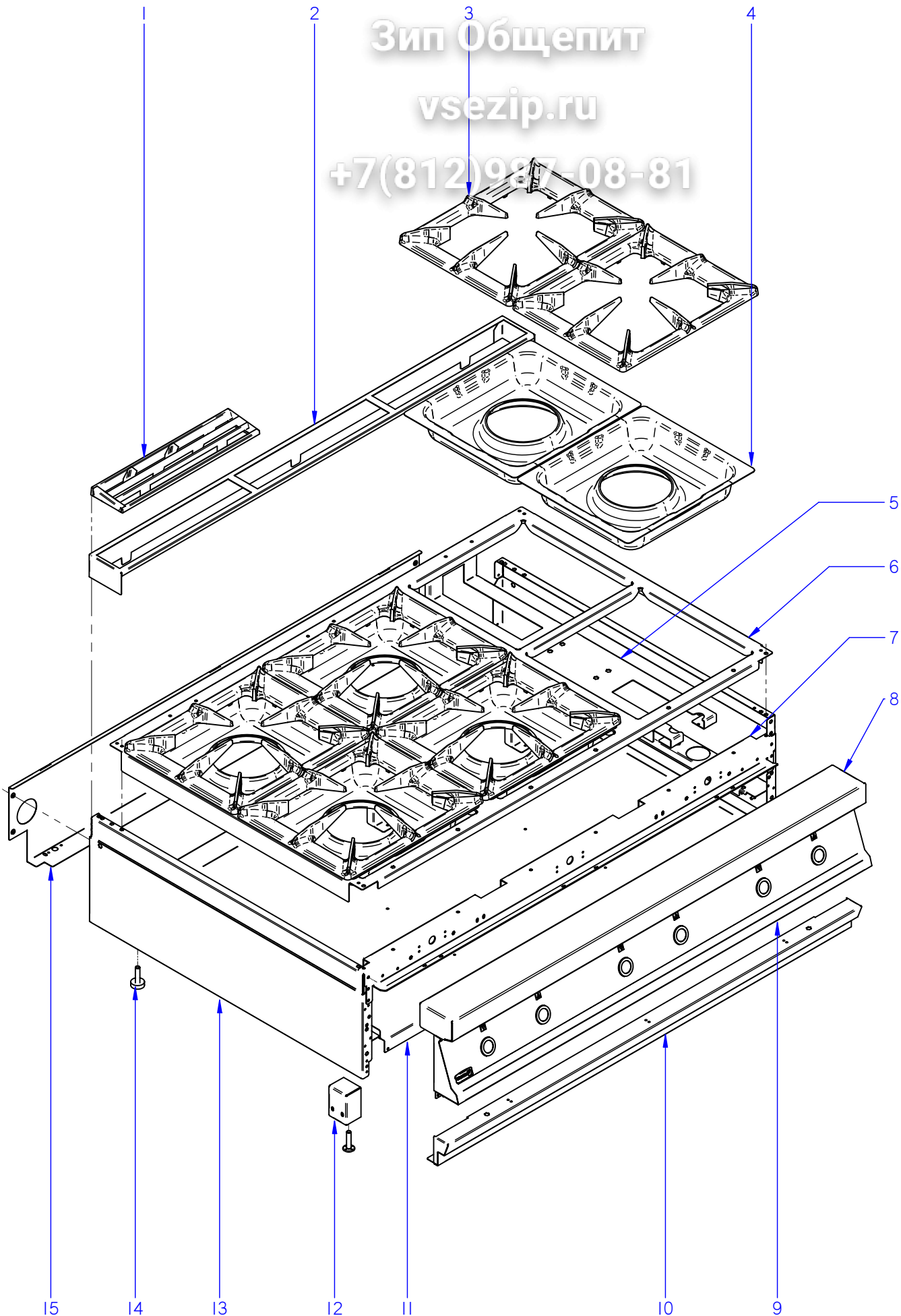

ITEM MARCADO EN COLOR = REPUESTO RECOMENDADO  
COLOURED ITEM = RECOMMENDED SPARE PART

N plano	Firma	Fecha	Aparato	MUEBLE	Lamina	Fagor Industrial S.Coop. <b>FAGOR</b>
C-2340	<i>(Signature)</i>	2009-06	COCINAS CG9-20 / CG9-40 / CG9-60		1	Oñate

MOD.	COCINAS	ZONA	MUEBLE / UNIT					
ITEM	CODIGO	DENOMINACION	TEXTO	CG9-20	CG9-40	CG9-60		
1	R205425000	EMBELLECEDOR ESMALTE	ENAMEL TRIM	1	2	3		
2	R205438000	SOPORTE EMBELLECEDOR 0,5 M	TRIM SUPPORT 0.5 M	1	—	—		
2	R205439000	SOPORTE EMBELLECEDOR 1 M	TRIM SUPPORT 1 M	—	1	—		
2	R205440000	SOPORTE EMBELLECEDOR 1,5 M	TRIM SUPPORT 1.5 M	—	—	1		
3	U035409000	PARRILLA GAMA 900	GRILL 900 RANGE	2	4	6		
4	U025473000	BACINETA QUEMADOR G900	BASIN BURNER G900	2	4	6		
5	U022617000	LISTON SOP. QUEMADOR G900	BURNER SUPPORT STRIP	1	2	3		
5	U022651000	LISTON SOP. QUEMADOR G900	BURNER SUPPORT STRIP	1	2	3		
	Q221343000	REMACHE EXAGONAL M6	HEXAGONAL RIVET M6	4	8	12		
	Q221342000	REMACHE EXAGONAL M5	HEXAGONAL RIVET M5	4	6	8		
6	U025474000	MESA 0,5 M G900	BENCH 0.5 M G900	1	—	—		
6	U025472000	MESA 1 M G900	BENCH 1 M G900	—	1	—		
6	U025475000	MESA 1,5 M G900	BENCH 1.5 M G900	—	—	1		
	Q152004000	TORNIL, APLASTADO M5x13 A304	FLAT HEADED BOLT M5x13 A304	8	10	12		
	Q221342000	REMACHE EXAGONAL M5	HEXAGONAL RIVET M5	2	4	6		
7	X162690000	ESCUA INTER AMAR ANTE 0,5 M	BRACKET INTER FASTE. FRONT	1	—	—		
7	U022632000	ESCUA INTER AMAR ANTE 1 M	BRACKET INTER FASTE. FRONT	—	1	—		
7	U032625000	ESCUA INTER AMAR ANTE 1,5 M	BRACKET INTER FASTE. FRONT	—	—	1		
	Q221342000	REMACHE EXAGONAL M5	HEXAGONAL RIVET M5	4	4	6		
	Q012032000	TORNILLO EXAGONAL M5x15	HEXAGONAL BOLT M5x15	6	6	6		
	Q152004000	TORNIL, APLASTADO M5x13 A304	FLAT HEADED BOLT M5x13 A304	4	6	9		
	Q302022000	ARANDELA 16x6x1,2 A304	WASHER 16x6x1.2 A304	4	6	9		
8	R045416000	ANTERIOR MESA 0,5 M	BENCH FRONT 0.5 M	1	—	—		
8	S105402000	ANTERIOR MESA 1 M	BENCH FRONT 1 M	—	1	—		
8	U035406000	ANTERIOR MESA 1,5 M	BENCH FRONT 1.5 M	—	—	1		
9	U012809000	PORTAMANDOS COMPL. CG9-20	COMPL. CONTROL HOLDER CG9	1	—	—		
9	U022856000	PORTAMANDOS COMPL. CG9-40	COMPL. CONTROL HOLDER CG9	—	1	—		
9	U032814000	PORTAMANDOS COMPL. CG9-60	COMPL. CONTROL HOLDER CG9	—	—	1		
	U022836000	ESCUDO FAGOR	FAGOR EMBLEM	1	1	1		
	Q221023000	CLIP SUJECIÓN RÁPIDA Ø5	RAPID CONNECT CLIP Ø5	2	2	2		

# Зип Общепит

MOD.		COCINAS		MUEBLE / UNIT		
ITEM	CODIGO	DENOMINACION	TEXTO	CG9-20	CG9-40	CG9-60
10	R062805000	ZOCALO 0,5 M	SKIRTING 0.5 M	1	-	-
10	H352817000	ZOCALO BAÑO MARIA	BAIN MARIE SKIRTING	-	1	-
10	U032809000	ZOCALO 1,5 M	SKIRTING 1.5 M	-	-	1
	Q419005000	REMACHE 4x8 ALMG3 / ALUMINIO	RIVET 4X8 ALMG3 / ALUMINIUM	2	2	2
11	U022631000	BASE 0,5 M GAS	BASE 0.5 M GAS	1	-	-
11	U022629000	BASE 1 M GAS	BASE 1 M GAS	-	1	-
11	U032622000	BASE 1,5 M GAS	BASE 1.5 M GAS	-	-	1
	Q419005000	REMACHE 4x8 ALMG3 / ALUMINIO	RIVET 4X8 ALMG3 / ALUMINIUM	4	9	16
12	H012805000	ESCUADRA AMARRE PATA	LEG FASTENING BRACKET	2	2	2
	Q162030000	TUERCA EXAGONAL M5	HEXAGONAL NUT M5	4	4	4
	Q302022000	ARANDELA 16x6x1,2 A304	WASHER 16x6x1.2 A304	4	4	4
	Q221345000	REMACHE EXAGONAL M10	HEXAGONAL RIVET M10	2	2	2
13	R062811000	PANEL LATERAL IZQUIERDO G900	LEFT SIDE PANEL G900	1	1	1
S/Nº	R062810000	PANEL LATERAL DERECHO G900	RIGHT SIDE PANEL G900	1	1	1
	Q221342000	REMACHE EXAGONAL M5	HEXAGONAL RIVET M5	2	6	6
	Q221343000	REMACHE EXAGONAL M6	HEXAGONAL RIVET M6	4	10	10
14	Z200107000	PATA	LEG	4	4	4
	Q221345000	REMACHE EXAGONAL M10	HEXAGONAL RIVET M10	4	4	4
S/Nº	X010503000	CIERRE MUELLE	LOCK SPRING	3	4	6
	Q419007000	REMACHE TUBULAR C/V Ø2x6	TUBULAR RIVET C/V Ø2x6	6	8	12
15	H012824000	PANEL POSTERIOR 0,5 M	REAR PANEL 0.5 M	1	-	-
15	H022809000	PANEL POSTERIOR 1 M	REAR PANEL 1 M	-	1	-
15	U572850000	PANEL POSTERIOR 1,5 M	REAR PANEL 1.5 M	-	-	1
	Q419005000	REMACHE 4x8 ALMG3 / ALUMINIO	RIVET 4X8 ALMG3 / ALUMINIUM	2	4	4
	Q302022000	ARANDELA 16x6x1,2 A304	WASHER 16x6x1.2 A304	4	4	6

Зип Общепит

vsezip.ru

+7(812)987-08-81

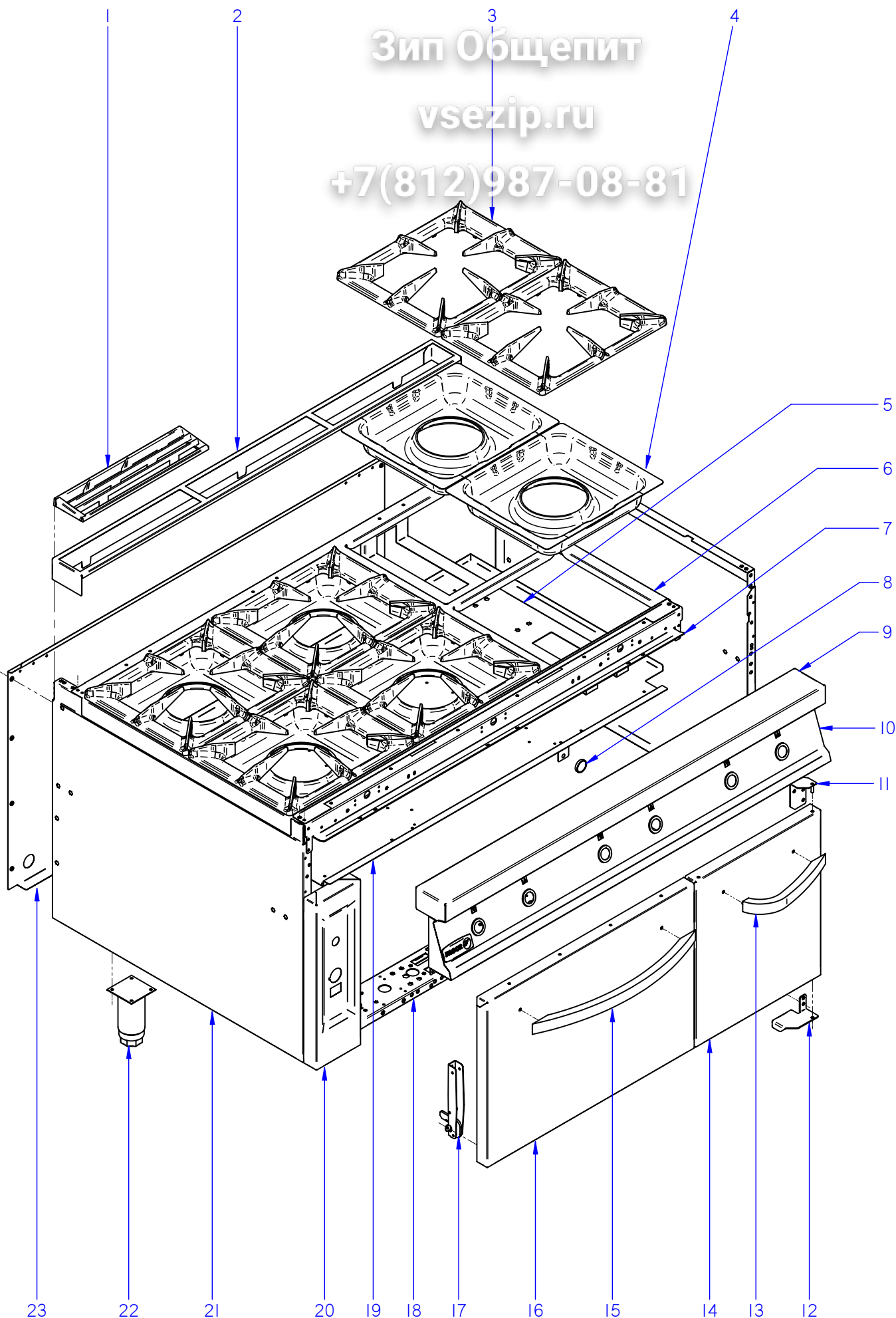

ITEM MARCADO EN COLOR = REPUESTO RECOMENDADO  
COLOURED ITEM = RECOMMENDED SPARE PART

N plano	Firma	Fecha	Aparato	MUEBLE	Lamina	Fagor Industrial S.Coop. <b>FAGOR</b>
C-2341	<i>(Signature)</i>	2009-06	COCINA CG9-41 / 61 / 82 / CGE9-41		2	Oñate

MOD.	COCINAS	ZONA	MUEBLE / UNIT					
ITEM	CODIGO	DENOMINACION	TEXTO	CG9-41	CG9-61	CG9-82	CG9-61 OP	CG9-41
1	R205425000	EMBELLECEDOR ESMALTE	ENAMEL TRIM	2	3	4	3	2
2	R205439000	SOPORTE EMBELLECEDOR 1 M	TRIM SUPPORT 1 M	1	—	2	—	1
2	R205440000	SOPORTE EMBELLECEDOR 1,5 M	TRIM SUPPORT 1.5 M	—	1	—	1	—
3	U035409000	PARRILLA GAMA 900	GRILL 900 RANGE	4	6	8	6	4
4	U025473000	BACINETA QUEMADOR G900	BASIN BURNER G900	4	6	8	6	4
5	U022617000	LISTON SOP. QUEMADOR G900	BURNER SUPPORT STRIP	2	3	4	3	2
5	U022651000	LISTON SOP. QUEMADOR G900	BURNER SUPPORT STRIP	2	3	4	3	2
	Q221343000	REMACHE EXAGONAL M6	HEXAGONAL RIVET M6	8	12	16	12	8
	Q221342000	REMACHE EXAGONAL M5	HEXAGONAL RIVET M5	4	8	16	8	4
6	U025472000	MESA 1 M G900	BENCH 1 M G900	1	—	2	—	1
6	U025475000	MESA 1,5 M G900	BENCH 1.5 M G900	—	1	—	1	—
	Q152004000	TORNIL, APLASTADO M5x13 A304	FLAT HEADED BOLT M5x13 A304	10	12	20	12	10
	Q221342000	REMACHE EXAGONAL M5	HEXAGONAL RIVET M5	4	6	8	6	4
7	U022632000	ESCUA INTER AMAR ANTE 1 M	BRACKET INTER FASTE. FRONT	1	—	2	—	1
7	U032625000	ESCUA INTER AMAR ANTE 1,5 M	BRACKET INTER FASTE. FRONT	—	1	—	1	—
	Q221342000	REMACHE EXAGONAL M5	HEXAGONAL RIVET M5	4	6	8	6	4
	Q012032000	TORNILLO EXAGONAL M5x15	HEXAGONAL BOLT M5x15	4	6	8	6	4
	Q152004000	TORNIL, APLASTADO M5x13 A304	FLAT HEADED BOLT M5x13 A304	6	6	12	6	6
	Q302022000	ARANDELA 16x6x1,2 A304	WASHER 16x6x1.2 A304	6	6	12	6	6
8	X960501000	IMAN	MAGNET	—	2	—	—	—
S/Nº	X960502000	FIJACION IMAN	MAGNET ATTACHMENT	—	2	—	—	—
	Q012021000	TORNILLO EXAGONAL M4X10	HEXAGONAL BOLT M4x10	—	2	—	—	—
	Q232020000	ARANDELA A4	WASHER A4	—	2	—	—	—
9	S105402000	ANTERIOR MESA 1 M	BENCH FRONT 1 M	1	—	—	—	1
9	U035406000	ANTERIOR MESA 1,5 M	BENCH FRONT 1.5 M	—	1	—	1	—
9	U125401000	ANTERIOR MESA 2 M	BENCH FRONT 2 M	—	—	1	—	—
	Q152004000	TORNIL, APLASTADO M5x13 A304	FLAT HEADED BOLT M5x13 A304	2	3	4	3	2
	Q302022000	ARANDELA 16x6x1,2 A304	WASHER 16x6x1.2 A304	2	3	4	3	2

+7(812)987-08-81

MOD.	COCINAS	ZONA	MUEBLE / UNIT					
ITEM	CODIGO	DENOMINACION	TEXTO	CG9-41	CG9-61	CG9-82	CG9-61 OP	CG9-41
10	U022852000	PORTAMANDOS COMPL. CG9-41	CONTROL HOLDER CG9-41	1	—	—	—	1
10	U032811000	PORTAMANDOS COMPL. CG9-61	CONTROL HOLDER CG9-61	—	1	—	—	—
10	U122831000	PORTAMANDOS COMPL. CG9-82	CONTROL HOLDER CG9-82	—	—	1	—	—
10	U102814000	PORTAMANDOS COMP. CG9-61OP	CONTROL HOLDER CG9-61OP	—	—	—	1	—
	U022836000	ESCUDO FAGOR	FAGOR EMBLEM	1	1	1	1	1
	Q221023000	CLIP SUJECIÓN RÁPIDA Ø5	RAPID CONNECT CLIP Ø5	2	2	2	2	2
11	U032619000	BISAGRA SUPERIOR DERECHA	UPPER RIGHT HINGE	—	1	—	—	—
	Q221342000	REMACHE EXAGONAL M5	HEXAGONAL RIVET M5	—	2	—	—	—
12	U020511000	BISAGRA DERECHA INFERIOR	LOWER RIGHT HINGE	—	1	—	—	—
	Q232040000	ARANDELA A6	WASHER A6	—	1	—	—	—
	X960504000	TORNILLO DE GIRO M8	ROTATION BOLT M8	—	1	—	—	—
	Q012042000	TORNILLO EXAGONAL M6x15 A304	HEXAGONAL BOLT M6x15 A304	—	2	—	—	—
	Q302022000	ARANDELA 16x6x1,2 A304	WASHER 16x6x1.2 A304	—	2	—	—	—
13	U020507000	ASA ARMARIO COMPLETO G900	FULL CUPBOARD HANDLE G900	—	1	—	—	—
	Q162040000	TUERCA EXAGONAL M6	HEXAGONAL NUT M6	—	2	—	—	—
	Q302022000	ARANDELA 16x6x1,2 A304	WASHER 16x6x1.2 A304	—	2	—	—	—
14	U020536000	PUERTA LATERAL G900	SIDE DOOR G900	—	1	—	—	—
	Q419005000	REMACHE 4x8 ALMG3 / ALUMINIO	RIVET 4X8 ALMG3 / ALUMINIUM	—	4	—	—	—
15	U020504000	ASA DE HORNO COMPLETA G900	COMPL. OVEN HANDLE G900	1	1	2	1	1
	Q012041000	TORNILLO EXAGONAL M6x10	HEXAGONAL BOLT M6x10	2	2	4	2	2
	Q302022000	ARANDELA 16x6x1,2 A304	WASHER 16x6x1.2 A304	2	2	4	2	2
	<b>12038310</b>	<b>KIT PUERTA HORNO</b>	<b>OVEN DOOR KIT</b>	<b>1</b>	<b>1</b>	<b>2</b>	—	<b>1</b>
16	U910501000	PUERTA DE HORNO	OVEN DOOR	1	1	2	—	1
16	U100514000	PUERTA DE HORNO GRANDE	OVEN DOOR	—	—	—	1	—
16	U100522000	PUERTA DE HORNO OP	OVEN DOOR OP	—	—	—	1	—
17	U020528000	BISAGRA CIERRE HORNO	OVEN LOCK HINGE	2	2	4	2	2
	Q152022000	TORNILLO M6x8	BOLT M6x8	6	6	12	6	6
18	U022625000	LISTON SOPORTE PATAS 1 M	LEG SUPPORT STRIP 1 M	2	—	—	—	2
18	U032615000	LISTON SOPORTE PATAS 1,5 M	LEG SUPPORT STRIP 1.5 M	—	2	—	—	—
18	U122606000	LISTON SOPORTE PATAS 2 M	LEG SUPPORT STRIP 2 M	—	—	2	—	—
18	U102611000	LISTON SOPORTE PATAS 1,5 M OP	LEG SUPPORT STRIP 1.5 M	—	—	—	2	—

# Зип Общепит

vsezip.ru

ZONA

MUEBLE / UNIT

MOD.	COCINAS		ZONA	MUEBLE / UNIT				
ITEM	CODIGO	DENOMINACION	TEXTO	CG9-41	CG9-61	CG9-82	CG9-61 OP	CGE9-41
19	U022613000	BASE BANDEJAS 1 M	TRAY BASE 1 M	1	-	2	-	1
19	U022626000	BASE BANDEJAS 1,5 M	TRAY BASE 1.5 M	-	1	-	-	-
19	U102615000	BASE BANDEJAS 1,5 M OP	TRAY BASE 1.5 M OP	-	-	-	1	-
	Q419005000	REMACHE 4x8 ALMG3 / ALUMINIO	RIVET 4X8 ALMG3 / ALUMINIUM	2	2	4	2	2
	Q152004000	TORNIL, APLASTADO M5x13 A304	FLAT HEADED BOLT M5x13 A304	3	3	6	3	3
20	U022843000	PORTAMANDOS LATERAL HORNO	OVEN SIDE CONTROL HOLDER	1	1	2	1	-
20	U962829000	PORTAMAND. LATERAL HORNO AD	OVEN SIDE CONTROL HOLD. AD	1	1	2	1	-
20	U672855000	PORTAMANDOS LATERAL HORNO	OVEN SIDE CONTROL HOLDER	-	-	-	-	1
20	12041036	PORTAM. LATERAL HORNO ELECT.	OVEN SIDE CONTROL HOLDER	-	-	-	-	1
	Q152004000	TORNIL, APLASTADO M5x13 A304	FLAT HEADED BOLT M5x13 A304	2	2	4	2	2
21	X162813000	PANEL LATERAL IZQUIERDO G900	LEFT SIDE PANEL G900	1	1	2	1	1
S/Nº	U022842000	PANEL LATERAL DERECHO G9-00	RIGHT SIDE PANEL G9-00	1	-	2	-	1
S/Nº	X162814000	PANEL LATERAL DERECHO G9-00	RIGHT SIDE PANEL G9-00	-	1	-	-	-
S/Nº	U022819000	PANEL LATERAL DERECHO G9-00	RIGHT SIDE PANEL G9-00	-	-	-	1	-
	Q221343000	REMACHE EXAGONAL M6	HEXAGONAL RIVET M6	22	22	30	22	22
	Q221342000	REMACHE EXAGONAL M5	HEXAGONAL RIVET M5	22	22	44	22	22
	Q012043000	TORNILLO EXAGONAL M6x20 A304	HEXAGONAL BOLT M6x20 A304	4	4	4	4	4
	Q152004000	TORNILLO APLASTADO M5x13 A304	FLAT HEADED BOLT M5x13 A304	6	6	6	6	6
22	X260151000	PATA REGULABLE	ADJUSTABLE LEG	4	4	4	4	4
	Q411304000	REMACHE AVIBULB Ø 4,8	AVIBULB RIVET Ø 4.8	16	16	16	16	16
23	U562853000	PANEL POSTERIOR 1 M	REAR PANEL 1 M	1	-	-	-	1
23	U582852000	PANEL POSTERIOR 1,5 M	REAR PANEL 1.5 M	-	1	-	1	-
23	U592852000	PANEL POSTERIOR 2 M	REAR PANEL 2 M	1	-	1	-	1
	Q419005000	REMACHE 4x8 ALMG3 / ALUMINIO	RIVET 4X8 ALMG3 / ALUMINIUM	8	11	16	11	8



Зип Общепит

vsezip.ru

+7(812)987-05-81

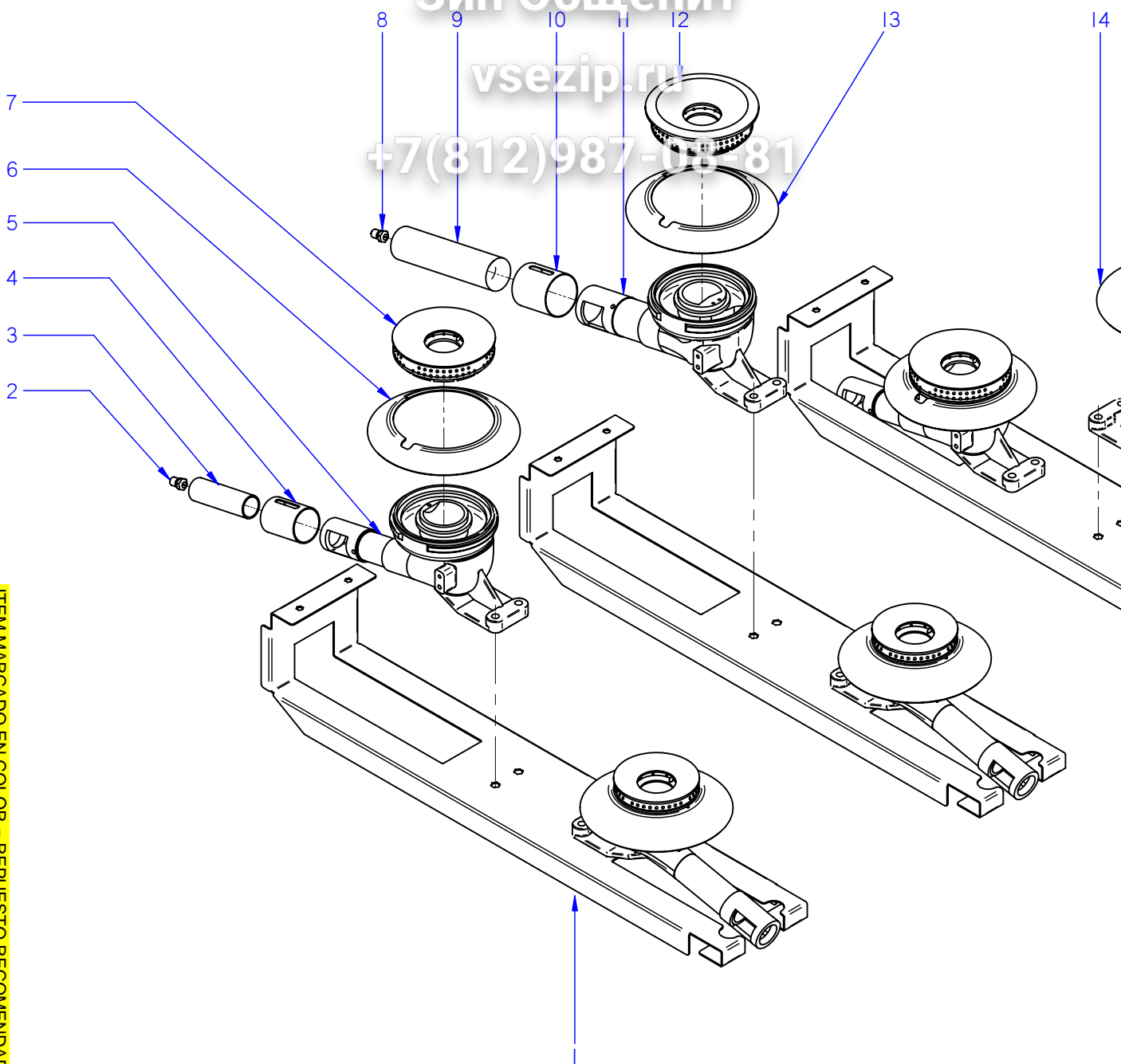

ITEM MARCADO EN COLOR = REPUESTO RECOMENDADO  
COLOURED ITEM = RECOMMENDED SPARE PART

N plano	C-2342
Firma	<i>[Signature]</i>
Fecha	2009-06
Aparato	COCINA CG-9-20 / 40 / 60 / CGE9-41
QUEMADORES	
Lamina	3
Fogor	Industri al s. Coop. <b>FAGOR</b>
Onete	

MOD.		COCINAS		ZONA		QUEMADORES / BURNERS			
ITEM	CODIGO	DENOMINACION	TEXTO	CG9-20	CG9-40	CG9-60	CGE9-41		
1	U022617000	LISTON SOP. QUEMADOR G900	BURNER SUPPORT STRIP	1	2	3	2		
1	U022651000	LISTON SOP. QUEMADOR G900	BURNER SUPPORT STRIP	1	2	3	2		
	Q221343000	REMACHE EXAGONAL M6	HEXAGONAL RIVET M6	4	8	12	8		
	Q221342000	REMACHE EXAGONAL M5	HEXAGONAL RIVET M5	4	6	8	4		
2	631000000	TOBERA Ø 1,40 BP (8000)	NOZZLE Ø 1.40 BP (8000)	1	1	2	1		
2	U112402000	TOBERA Ø 2,10 GN (8000)	NOZZLE Ø 2,10 GN (8000)	1	1	2	1		
3	U565700000	VENTURI QUEMADOR 8000	VENTURI BURNER 8000	1	1	2	1		
4	U265702000	REGULADOR AIRE	AIR CONTROLLER	1	1	2	1		
	Q132054000	VARILLA ROSCADA M6 x 12	THREADED ROD M6 x 12	1	1	2	1		
	Q162004000	TUERCA EXAGONAL M6	HEXAGONAL NUT M6	1	1	2	1		
5	U025710000	CUERPO QUEMADOR 8000 Kcal/H	BURNER BODY 8000 Kcal/h	1	1	2	1		
	Q372004000	PASADOR ELASTICO 5x20	ELASTIC PIN 5x20	1	2	2	2		
6	U915703000	PROTEC. PILOTO QUEMAD. 7000	BURNER PILOT GUARD 7000	1	1	2	1		
	12093788	ESPARRAGO ALLEN M3x12	ALLEN M3x12 ROD	1	1	2	1		
7	U135702500	QUEMADOR 8000	BURNER 8000	1	1	2	1		
	Q371026000	MANGUITO DE SUJECION Ø 4x14	HANDLE Ø 4x14	1	1	2	1		
	Q012045000	TORNILLO EXAGONAL M6x30 A304	HEXAGONAL BOLT M6x30 A304	1	1	2	1		
	Q302022000	ARANDELA 16x6x1,2 A304	WASHER 16x6x1.2 A304	1	1	2	1		
	U565011000	TUERCA GUIA	GUIDE NUT	1	1	2	1		
8	U112401000	TOBERA Ø 1,55 BP (10500)	NOZZLE Ø 1.55 BP (10500)	—	1	1	1		
8	631600000	TOBERA Ø 2,40 GN (10500)	NOZZLE Ø 2.40 GN (10500)	—	1	1	1		
9	U235706000	VENTURI 10.500	VENTURI 10,500	—	1	1	1		
9	U235707000	VENTURI 10.500	VENTURI 10,500	—	1	1	1		
10	U025706000	REGULADOR DE AIRE 10.000	AIR CONTROL 10.000	—	1	1	1		
	Q132054000	VARILLA ROSCADA M6x12	THREADED ROD M6X12	—	1	1	1		
	Q162004000	TUERCA EXAGONAL M6	HEXAGONAL NUT M6	—	1	1	1		
11	U025711000	CUERPO QUEMADOR 10.000Kcal/H	BURNER BODY 10,000 Kcal/H	—	1	1	1		
	Q372004000	PASADOR ELASTICO 5x20	ELASTIC PIN 5x20	—	1	1	1		
	Q371028000	MANGUITO DE SUJECION Ø 3x14	HANDLE Ø 3x14	—	2	2	2		
12	U235701500	DIFUSOR 10.500 Kcal/H	DIFFUSER 10.500 Kcal/H	—	1	1	1		
12	12047137	DIFUSOR 10.500 (AGUJ Y PINTA)	DIFFUSER 10.500	—	1	1	1		



Зип Общепит

vseip.ru

+7(812)987-08-81

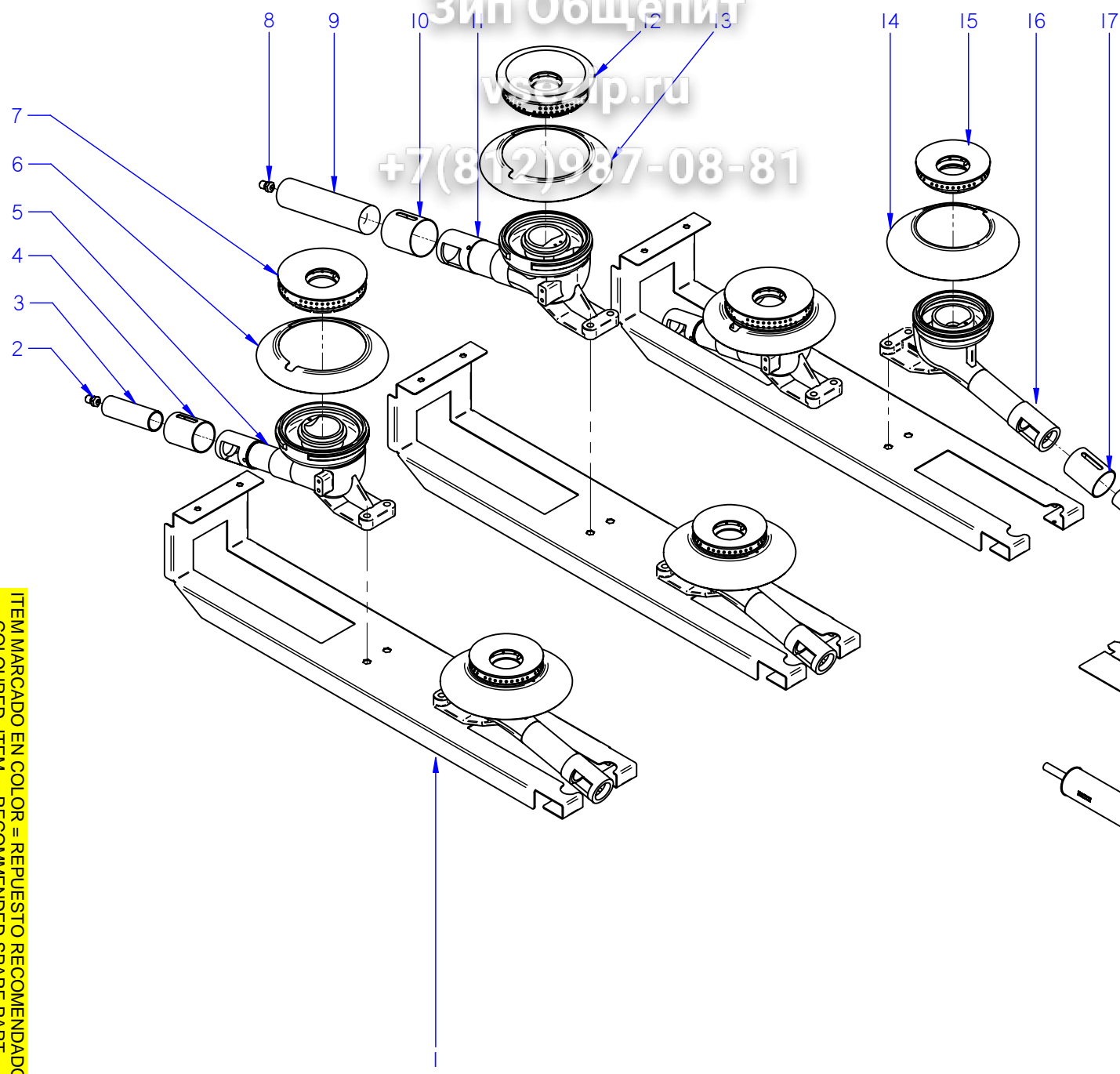

ITEM MARCADO EN COLOR = REPUESTO RECOMENDADO  
COLOURED ITEM = RECOMMENDED SPARE PART

N plano	C-2343
Firma	
Fecha	2009-06
Aparato	COCINA CG9-41 / 61 / 82 / 61 OP
QUEMADORES	
Lamina	4
Fogor	Industri al s. Coop. <b>FAGOR</b>
Opote	

MOD.		COCINAS		ZONA		QUEMADORES / BURNERS			
ITEM	CODIGO	DENOMINACION	TEXTO	CG9-41	CG9-61	CG9-82	CG9-61 OP		
1	U022617000	LISTON SOP. QUEMADOR G900	BURNER SUPPORT STRIP	1	2	3	2		
1	U022651000	LISTON SOP. QUEMADOR G900	BURNER SUPPORT STRIP	1	2	3	2		
2	0631000000	TOBERA Ø 1,40 BP (8000)	NOZZLE Ø 1.40 BP (8000)	1	2	2	2		
2	U112402000	TOBERA Ø 2,10 GN (8000)	NOZZLE Ø 2,10 GN (8000)	1	2	2	2		
3	U565700000	VENTURI QUEMADOR 8000	VENTURI BURNER 8000	1	2	2	2		
4	U265702000	REGULADOR AIRE	AIR CONTROLLER	1	2	2	2		
	Q132054000	VARILLA ROSCADA M6 x 12	THREADED ROD M6 x 12	1	2	2	2		
	Q162004000	TUERCA EXAGONAL M6	HEXAGONAL NUT M6	1	2	2	2		
5	U025710000	CUERPO QUEMADOR 8000 Kcal/H	BURNER BODY 8000 Kcal/h	1	2	2	2		
	Q372004000	PASADOR ELASTICO 5x20	ELASTIC PIN 5x20	1	2	2	2		
6	U915703000	PROTEC. PILOTO QUEMAD. 7000	BURNER PILOT GUARD 7000	1	2	2	2		
	12093788	ESPARRAGO ALLEN M3x12	ALLEN M3x12 ROD	1	2	2	2		
7	U135702500	QUEMADOR 8000	BURNER 8000	1	2	2	2		
	Q371026000	MANGUITO DE SUJECION Ø 4x14	HANDLE Ø 4x14	1	2	2	2		
	Q012045000	TORNILLO EXAGONAL M6x30 A304	HEXAGONAL BOLT M6x30 A304	1	4	2	4		
	U565011000	TUERCA GUIA	GUIDE NUT	1	2	2	2		
8	U112401000	TOBERA Ø 1,55 BP (10500)	NOZZLE Ø 1.55 BP (10500)	1	1	2	1		
8	631600000	TOBERA Ø 2,40 GN (10500)	NOZZLE Ø 2.40 GN (10500)	1	1	2	1		
9	U235706000	VENTURI 10.500	VENTURI 10,500	1	1	2	1		
9	U235707000	VENTURI 10.500	VENTURI 10,500	1	1	2	1		
10	U025706000	REGULADOR DE AIRE 10.000	AIR CONTROL 10.000	1	1	2	1		
	Q132054000	VARILLA ROSCADA M6x12	THREADED ROD M6X12	1	1	2	1		
	Q162004000	TUERCA EXAGONAL M6	HEXAGONAL NUT M6	1	1	2	1		
11	U025711000	CUERPO QUEMADOR 10.000Kcal/H	BURNER BODY 10,000 Kcal/H	1	1	2	1		
	Q371028000	MANGUITO DE SUJECION Ø 3x14	HANDLE Ø 3x14	1	1	2	1		
	Q372004000	PASADOR ELASTICO 5x20	ELASTIC PIN 5x20	1	1	2	1		
12	U235701500	DIFUSOR 10.500 Kcal/H	DIFFUSER 10.500 Kcal/H	1	1	2	1		
12	12047137	DIFUSOR 10.500 (AGUJ Y PINTA)	DIFFUSER 10.500	1	1	2	1		
	Q012045000	TORNILLO EXAGONAL M6x30 A304	HEXAGONAL BOLT M6x30 A304	1	1	2	1		
13	U915703000	PROTEC. PILOTO QUEMAD. 7000	BURNER PILOT GUARD 7000	1	1	2	1		
	12093788	ESPARRAGO ALLEN M3x12	ALLEN M3x12 ROD	1	1	2	1		

MOD.		COCINAS		ZONA		QUEMADORES / BURNERS			
ITEM	CODIGO	DENOMINACION	TEXTO	CG9-41	CG9-61	CG9-82	CG9-61 OP		
14	U025712000	PROTEC. PILOTO QUEMAD. 4000	BURNER PILOT GUARD 4000	2	3	4	3		
	12093788	ESPARRAGO ALLEN M3x12	ALLEN M3x12 ROD	2	3	4	3		
15	U445731500	QUEMADOR 4000 (00545-010)	BURNER 4000 (00545-010)	2	3	4	3		
15	U445731000	QUEMADOR 4000 (00545-010)	BURNER 4000 (00545-010)	1	2	3	2		
15	12039162	QUEMADOR 4000 4000 Kcal/H	BURNER 40004000 Kcal/H	1	2	3	2		
16	U025709000	CUERPO QUEMADOR 4000Kcal/H	BURNER BODY 4000 Kcal/H	2	3	4	3		
	Q371026000	MANGUITO DE SUJECION Ø 4x14	HANDLE Ø 4x14	2	3	4	3		
	Q372004000	PASADOR ELASTICO 5x20	ELASTIC PIN 5x20	2	3	4	3		
17	U265702000	REGULADOR AIRE	AIR CONTROLLER	2	3	4	3		
	Q132042000	VARILLA ROSCADA M6 x 15	THREADED ROD M6 x 15	2	3	4	3		
	Q162004000	TUERCA EXAGONAL M6	HEXAGONAL NUT M6	2	3	4	3		
18	U125720000	VENTURI QUEMADOR 4000 kcl	VENTURI BURNER 4000 kcl	2	3	4	3		
19	X312400000	TOBERA Ø 1,10 BP (4000)	NOZZLE Ø 1.10 BP (4000)	2	3	4	3		
19	U122407000	TOBERA Ø 1,05 BP (4000)	NOZZLE Ø 1.05 BP (4000)	2	3	4	3		
19	R302400000	TOBERA Ø 1,65 GN (4000)	NOZZLE Ø 1.65 GN (4000)	2	3	4	3		
20	U915613000	DEFLECTOR QUEMADOR HORNO	OVEN BURNER DEFLECTOR	2	2	4			
20	U105610000	DEFLECTOR QUEMADOR HORNO	OVEN BURNER DEFLECTOR				2		
21	U105712000	RAMA ENCENDIDO QUEM. HORNO	OVEN BURNER IGNITION BRANC				1		
	X205028000	BICONO Ø 6	BICONEØ 6				1		
	U105013000	TUERCA M10x1(024 0003.00)POL	NUT M10x1(024 0003.00)POL				1		
22	U105635000	AMARRE QUEMADOR HORNO(HG)	OVEN BURNER FASTENING (HG)	1	1	2	2		
	Q012031000	TORNILLO EXAGONAL M5x10 A304	HEXAGONAL BOLT M5x10 A304	2	2	4	4		
23	X505724000	MANGUITO PORTATOBERAS	NOZZLE HOLDER SLEEVE	1	1	2	2		
24	Q223019000	TUERCA 3/8 GAS LATÓN	NUT 3/8 GAS BRASS	1	1	2	2		
25	X505013000	REGULADOR DE AIRE POLIDORO	POLIDORO AIR CONTROL	1	1	2	2		
26	U105701000	QUEMADOR HORNO	OVEN BURNER.	1	1	2	2		
	Q042022000	TORNILLO AVELLLANADO M4X15	COUNTERSUNK BOLT M4x15	4	4	8	8		
S/Nº	U052401000	TOBERA Ø 1,45 BP	NOZZLE Ø 1.45 BP	1	1	2			
S/Nº	631000000	TOBERA Ø 1,40 BP	NOZZLE Ø 1.40 BP				1		
S/Nº	U262400000	TOBERA Ø 2,15 GN	NOZZLE Ø 2.15 GN	1	1	2			
S/Nº	U262400000	TOBERA Ø 2,15 GN	NOZZLE Ø 2.15 GN				1		

MOD.		COCINAS		ZONA					QUEMADORES / BURNERS				
ITEM	CODIGO	DENOMINACION	TEXTO	CG9-20 H	CG9-40 H	CG9-60 H	CG9-41 H	CG9-61 H	CG9-20 H	CG9-40 H	CG9-60 H	CG9-41 H	CG9-61 H
1	U022617000	LISTON SOP. QUEMADOR G900	BURNER SUPPORT STRIP	1	2	3	2	3	1	2	3	2	3
1	U022651000	LISTON SOP. QUEMADOR G900	BURNER SUPPORT STRIP	1	2	3	2	3	1	2	3	2	3
2	631000000	TOBERA Ø 1,40 BP (8000)	NOZZLE Ø 1.40 BP (8000)	1	3	5	3	5	1	3	5	3	5
2	U112402000	TOBERA Ø 2,10 GN (8000)	NOZZLE Ø 2,10 GN (8000)	1	3	5	3	5	1	3	5	3	5
3	U565700000	VENTURI QUEMADOR 8000	VENTURI BURNER 8000	1	3	5	3	5	1	3	5	3	5
4	U265702000	REGULADOR AIRE	AIR CONTROLLER	1	3	5	3	5	1	3	5	3	5
	Q132054000	VARILLA ROSCADA M6 x 12	THREADED ROD M6 x 12	1	3	5	3	5	1	3	5	3	5
	Q162004000	TUERCA EXAGONAL M6	HEXAGONAL NUT M6	1	3	5	3	5	1	3	5	3	5
5	U025710000	CUERPO QUEMADOR 8000 Kcal/H	BURNER BODY 8000 Kcal/h	1	3	5	3	5	1	3	5	3	5
	Q372004000	PASADOR ELASTICO 5x20	ELASTIC PIN 5x20	1	3	5	3	5	1	3	5	3	5
6	U915703000	PROTEC. PILOTO QUEMAD. 7000	BURNER PILOT GUARD 7000	1	3	5	3	5	1	3	5	3	5
	12093788	ESPARRAGO ALLEN M3x12	ALLEN M3x12 ROD	1	3	5	3	5	1	3	5	3	5
7	U135702500	QUEMADOR 8000	BURNER 8000	1	3	5	3	5	1	3	5	3	5
	Q371026000	MANGUITO DE SUJECION Ø 4x14	HANDLE Ø 4x14	1	3	5	3	5	1	3	5	3	5
	Q012045000	TORNILLO EXAGONAL M6x30 A304	HEXAGONAL BOLT M6x30 A304	1	3	5	3	5	1	3	5	3	5
	U565011000	TUERCA GUIA	GUIDE NUT	1	3	5	3	5	1	3	5	3	5
8	U112401000	TOBERA Ø 1,55 BP (10500)	NOZZLE Ø 1.55 BP (10500)	1	1	1	1	1	1	1	1	1	1
8	631600000	TOBERA Ø 2,40 GN (10500)	NOZZLE Ø 2.40 GN (10500)	1	1	1	1	1	1	1	1	1	1
9	U235706000	VENTURI 10.500	VENTURI 10,500	1	1	1	1	1	1	1	1	1	1
9	U235707000	VENTURI 10.500	VENTURI 10,500	1	1	1	1	1	1	1	1	1	1
10	U025706000	REGULADOR DE AIRE 10.000	AIR CONTROL 10.000	1	1	1	1	1	1	1	1	1	1
	Q132054000	VARILLA ROSCADA M6x12	THREADED ROD M6X12	1	1	1	1	1	1	1	1	1	1
	Q162004000	TUERCA EXAGONAL M6	HEXAGONAL NUT M6	1	1	1	1	1	1	1	1	1	1
11	U025711000	CUERPO QUEMADOR 10.000Kcal/H	BURNER BODY 10,000 Kcal/H	1	1	1	1	1	1	1	1	1	1
	Q371028000	MANGUITO DE SUJECION Ø 3x14	HANDLE Ø 3x14	1	2	2	2	2	1	2	2	2	2
	Q372004000	PASADOR ELASTICO 5x20	ELASTIC PIN 5x20	1	1	1	1	1	1	1	1	1	1
12	U235701500	DIFUSOR 10.500 Kcal/H	DIFFUSER 10.500 Kcal/H	1	1	1	1	1	1	1	1	1	1
12	12047137	DIFUSOR 10.500 (AGUJ Y PINTA)	DIFFUSER 10.500	1	1	1	1	1	1	1	1	1	1
	Q012045000	TORNILLO EXAGONAL M6x30 A304	HEXAGONAL BOLT M6x30 A304	1	1	1	1	1	1	1	1	1	1
	Q302022000	ARANDELA 16x6x1,2 A304	WASHER 16x6x1.2 A304	1	1	1	1	1	1	1	1	1	1

MOD.		COCINAS		ZONA QUEMADORES / BURNERS				
ITEM	CODIGO	DENOMINACION	TEXTO	CG9-20 H	CG9-40 H	CG9-60 H	CG9-41 H	CG9-61 H
13	U915703000	PROTEC. PILOTO QUEMAD. 7000	BURNER PILOT GUARD 7000	1	1	1	1	1
	12093788	ESPARRAGO ALLEN M3x12	ALLEN M3x12 ROD	1	1	1	1	1
14	U025712000	PROTEC. PILOTO QUEMAD. 4000	BURNER PILOT GUARD 4000	-	-	-	-	-
	12093788	ESPARRAGO ALLEN M3x12	ALLEN M3x12 ROD	-	-	-	-	-
15	U445731500	QUEMADOR 4000 (00545-010)	BURNER 4000 (00545-010)	-	-	-	-	-
	Q012045000	TORNILLO EXAGONAL M6x30 A304	HEXAGONAL BOLT M6x30 A304	-	-	-	-	-
	Q302022000	ARANDELA 16x6x1,2 A304	WASHER 16x6x1.2 A304	-	-	-	-	-
16	U025709000	CUERPO QUEMADOR 4000Kcal/H	BURNER BODY 4000 Kcal/H	-	-	-	-	-
	Q371026000	MANGUITO DE SUJECION Ø 4x14	HANDLE Ø 4x14	-	-	-	-	-
	Q372004000	PASADOR ELASTICO 5x20	ELASTIC PIN 5x20	-	-	-	-	-
17	U265702000	REGULADOR AIRE	AIR CONTROLLER	-	-	-	-	-
	Q132042000	VARILLA ROSCADA M6 x 15	THREADED ROD M6 x 15	-	-	-	-	-
	Q162004000	TUERCA EXAGONAL M6	HEXAGONAL NUT M6	-	-	-	-	-
18	U125720000	VENTURI QUEMADOR 4000 kcl	VENTURI BURNER 4000 kcl	-	-	-	-	-
19	X312400000	TOBERA Ø 1,10 BP (4000)	NOZZLE Ø 1.10 BP (4000)	-	-	-	-	-
19	R302400000	TOBERA Ø 1,65 GN (4000)	NOZZLE Ø 1.65 GN (4000)	-	-	-	-	-
20	U915613000	DEFLECTOR QUEMADOR HORNO	OVEN BURNER DEFLECTOR	-	-	-	2	2
	Q152004000	TORNIL, APLASTADO M5x13 A304	FLAT HEADED BOLT M5x13 A304	-	-	-	1	1
	Q302022000	ARANDELA 16x6x1,2 A304	WASHER 16x6x1.2 A304	-	-	-	1	1
22	U105635000	AMARRE QUEMADOR HORNO(HG)	OVEN BURNER FASTENING (HG)	-	-	-	1	1
	Q012031000	TORNILLO EXAGONAL M5x10 A304	HEXAGONAL BOLT M5x10 A304	-	-	-	2	2
	Q222041000	REMACHE EXAGONAL M4 (INOX)	HEXAGONAL RIVET M4 (INOX)	-	-	-	4	4
23	X505724000	MANGUITO PORTATOBERAS	NOZZLE HOLDER SLEEVE	-	-	-	1	1
24	Q223019000	TUERCA 3/8 GAS LATÓN	NUT 3/8 GAS BRASS	-	-	-	1	1
25	X505013000	REGULADOR DE AIRE POLIDORO	POLIDORO AIR CONTROL	-	-	-	1	1
	Q031322000	TORNILLO ALOMADO M4X15	CURVED SCREW M4X15	-	-	-	1	1
26	U105701000	QUEMADOR HORNO	OVEN BURNER.	-	-	-	1	1
	Q042022000	TORNILLO AVELLLANADO M4X15	COUNTERSUNK BOLT M4x15	-	-	-	4	4
S/Nº	U052401000	TOBERA Ø 1,45 BP	NOZZLE Ø 1.45 BP	-	-	-	1	1
S/Nº	U262400000	TOBERA Ø 2,15 GN	NOZZLE Ø 2.15 GN	-	-	-	1	1



Зип Общепит

vsezip.ru

+7(812)987-08-81

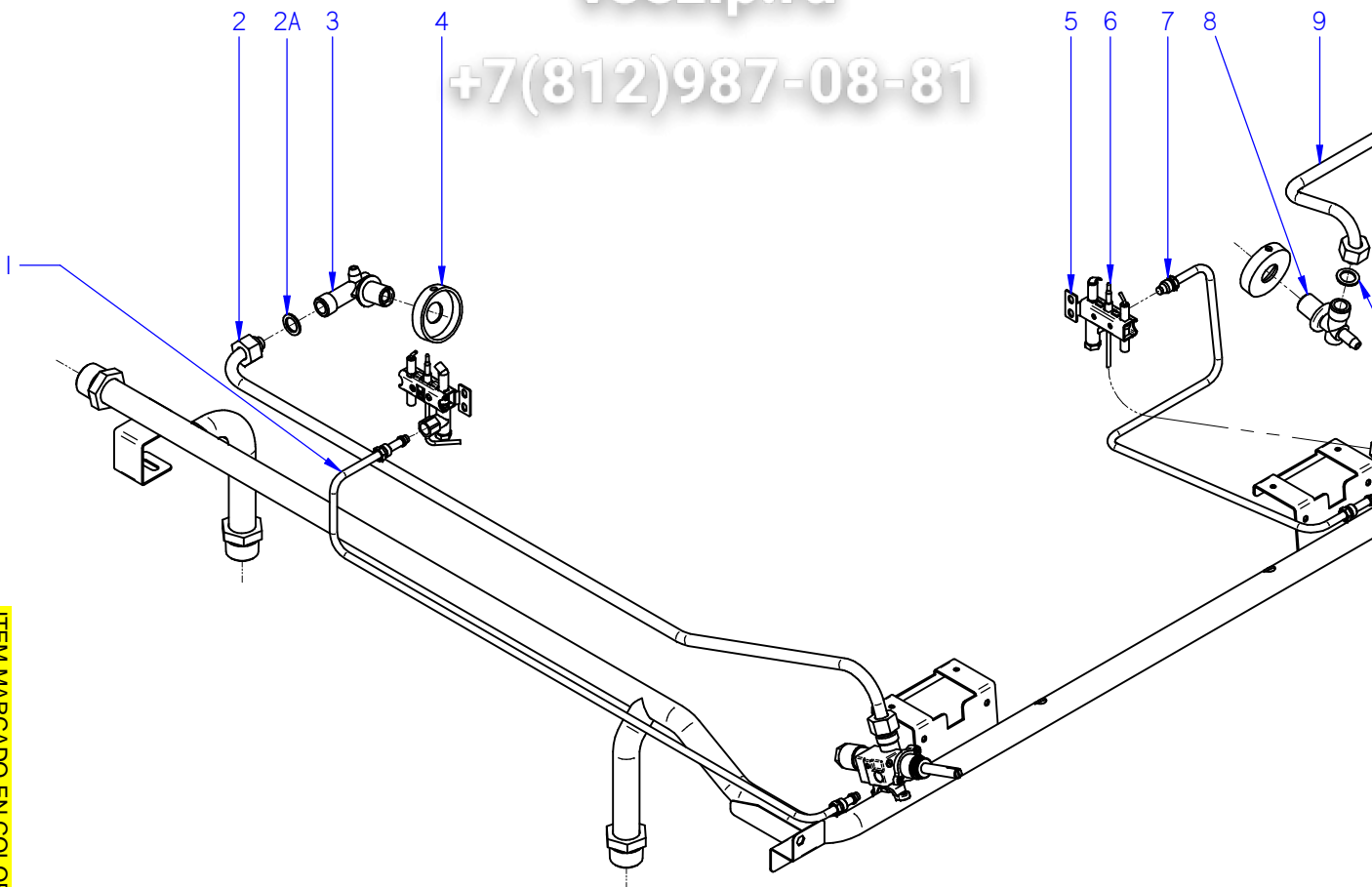

ITEM MARCADO EN COLOR = REPUESTO RECOMENDADO  
COLOURED ITEM = RECOMMENDED SPARE PART

N plano	Firma	Fecha	Aparato	Lamina	Orden
C-2344	<i>(Signature)</i>	2016-01	CONDUCIONES Y GRIFOS COCINA CG9-20 / 40 / 60 / CGE9-41	5	Fagor Industrial S. Coop. <b>FAGOR</b>





Зип Общепит

vsezip.ru

+7(812)987-08-81

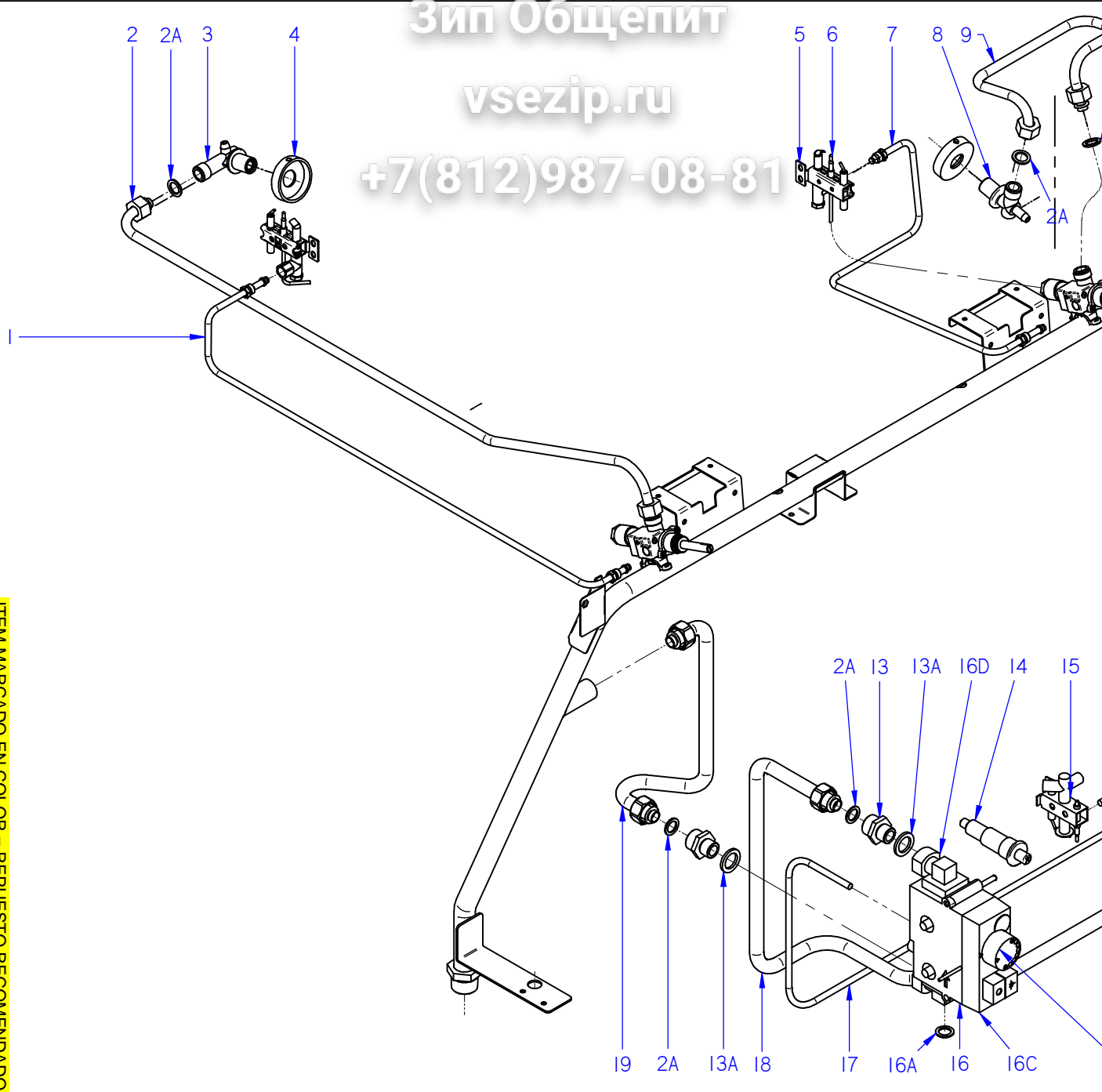

ITEM MARCADO EN COLOR = REPUUESTO RECOMENDADO  
COLOURED ITEM = RECOMMENDED SPARE PART

N plano	C-2345
Firma	<i>(Signature)</i>
Fecha	2016-01
Aparato	CONDUCCIONES Y GRIFOS COCINA CG9-41 / 61 / 82 / 61 OP
Lamina	6
Fogor Industrial S.Coop. Onete	<b>FAGOR</b>

MOD.		COCINAS		ZONA		CONDUCCIONES Y GRIFOS / PIPES AND TA			
ITEM	CODIGO	DENOMINACION	TEXTO	CG9-41	CG9-61	CG9-82	CG9-61 OP		
1	12010670	TUBO PILOTO POST. COMPL. G900	REAR PILOT PIPE COMPL. G900	2	3	4	3		
S/Nº	12008715	RACORD BICONO 6 958.031	BICONE CONNECTION 6 958.031	4	6	8	6		
2	12009286	CON. QUEMADOR POSTE. COM. AD	REAR BURNER UNIT COMP. AD	2	3	4	3		
2A	12130056	JUNTA BELPA CSA90 14x10.3x3	BELPA JOINT CSA90 14x10.3x3	6	14	12	20		
3	U915014000	PORTATOVERAS HORNO	OVEN NOZZLE HOLDER	2	3	4	3		
	Q153002000	TORNILLO TAPON	CAP BOLT	2	3	4	3		
4	U022619000	POSICIONADOR PORTATOB. 4000	NOZZLE-HOLDER POSITION. 4000	3	5	6	5		
S/Nº	U022620000	POSICIONADOR PORTATOB. G900	NOZZLE-HOLDER POSITION. G900	1	1	2	1		
5	12005260	PILOTO COMPL. COCINAS 1 LLAM	1 FLAME COMPLETE PILOT	4	6	8	6		
S/Nº	U442137000	INYECTOR Ø 0,4 GN	INJECTOR Ø 0.4 GN.	4	6	8	6		
6	U222130000	TERMOPAR L=600	THERMOCOUPLE L=600	2	3	4	3		
S/Nº	U262130000	TERMOPAR L=1000	THERMOCOUPLE L=1000	2	3	4	3		
7	12010672	TUBO PILOTO ANT. COMPLE. G900	FRONT PILOT PIPE COMP. G900	2	3	4	3		
S/Nº	12008715	RACORD BICONO 6 958.031	BICONE CONNECTION 6 958.031	4	6	8	6		
8	U265033000	PORTATOVERAS Ø10	NOZZLE HOLDER Ø10	2	3	4	3		
	Q153002000	TORNILLO TAPON	CAP BOLT	2	3	4	3		
9	12009185	CONDUC. QUEMADOR ANT.COM AD	FRONT BURNER PIPE COMPL.AD	2	3	4	3		
10	U912115000	GRIFO 18700 BY-PASS 0,75	TAP 18700 BY-PASS 0.75	2	3	4	3		
10	U912109000	GRIFO 18700 BY-PASS 1,15	TAP 18700 BY-PASS 1.15	1	2	2	2		
10	U912117000	GRIFO 18700 BY-PASS 1,45	TAP 18700 BY-PASS 1.45	1	1	2	1		
S/Nº	U912104000	BRIDA AMARRE GRIFO 1/2"	TAP FASTENING FLANGE 1/2"	4	6	8	6		
S/Nº	Q122032000	TORNILLO ALLEN M5x15	ALLEN BOLT M5x15	4	6	8	6		

# Зип Общепит

MOD. COCINAS ZCNA CONDUCCIONES Y GRIFOS / PIPES AND TAPS

vsezip.ru

+7(812)987-08-81

ITEM	CODIGO	DENOMINACION	TEXTO	CG9-41	CG9-61	CG9-82	CG9-61 OP
11	U022117000	MANDO MONT COCINA GAS Ø8	GAS COOK. ASSEMBLY CTRL Ø8	4	6	8	6
12	U025039000	DISTRIBUIDOR COMPLET. CG9-41	COMPLETE DISTRIBUTOR CG9-41	1	-	2	-
12	U025066000	DISTRIBUIDOR COMPLET. CG9-41	COMPLETE DISTRIBUTOR CG9-41	1	-	2	-
12	U035004000	DISTRIBUIDOR COMPLET. CG9-61	COMPLETE DISTRIBUTOR CG9-61	-	1	-	1
12	U035005000	DISTRIBUIDOR COMPLET. CG9-61	COMPLETE DISTRIBUTOR CG9-61	-	1	-	1
	Q152004000	TORNILLO APLASTADO M5x13	FLAT HEAD SCREW M5X13	2	2	8	2
13	U202103000	MANGUITO REDUCCION 1/2-3/8"	REDUCTION HOSE 1/2-3/8"	2	2	4	2
13A	12010057	ARANDELA 23,5X17,60X1,5	WASHER 23,5X17,60X1,5	2	2	4	2
14	S113034000	PIEZOELECTRICO	PIEZOELECTRIC	1	1	2	1
14	12043897	PIEZOELECTRICO COMPLETO	COMPLETE PIEZOELECTRIC	1	1	2	1
S/Nº	12043907	ANILLO ADAPTADOR	ADAPTER RING	1	1	2	1
15	U322118000	PILOTO COMPLETO 100.062	COMPLETE PILOT LIGHT 100,062	1	1	2	1
S/Nº	X022131000	BUJIA	SPARK PLUG	1	1	2	1
S/Nº	U442137000	INYECTOR Ø 0,4 GN	INJECTOR Ø 0.4 GN.	1	1	2	1
S/Nº	U562130000	TERMOPAR L=850	THERMOCOUPLE L=850	1	1	2	1
16	12009530	VALVULA MINISIT 0710.654	VALVE MINISIT 0710.654	1	1	2	1
16A	12010282	JUNTA TORICA 25,4x20,2x2,6	O-RING 25.4x20.2x2.6	2	2	4	2
16B	12008789	MANDO NEGRO MINI 916.124	BLACK CTRL. MINI 916.124	1	1	2	1
16C	12008932	CUBIERTA MINISIT 903.052	COVER MINISIT 903.052	1	1	2	1
16D	12008944	RACOR 3/8 906.252	CONNECTION 3/8 906.252	2	2	4	2
17	U025062000	TUBO PILOTO EUROSIT QUEM.	PILOT PIPE EUROSIT BURNER	1	1	2	-
17	U105008000	TUBO PILOTO HORNO	PILOT PIPE BURNER	-	-	-	1
S/Nº	12008715	RACORD BICONO 6 958.031	BICONE CONNECTION 6 958.031	2	2	4	2
18	U025061000	TUBO COMPLETO EUROSIT QUEMA.	COMPLETE PIPE EUROSIT BURNER	1	1	2	-
18	U105002000	TUBO COMPLETO QUEMADOR	COMPLETE PIPE BURNER	-	-	-	1
19	U025050000	ENTRADA MINISIT COMPL CG900	INPUT MINISIT COMPL CG900	1	1	2	1



# Зип Общепит

<b>MOD.</b>	<b>COCINAS</b>	<b>ZCNA</b>	<b>CONDUCCIONES Y GRIFOS / PIPES AND TAPS</b>
-------------	----------------	-------------	---

ITEM	CODIGO	DENOMINACION	TEXTO	CG9-20 H	CG9-40 H	CG9-60 H	CG9-41 H	CG9-61 H
11	U022117000	MANDO MONT COCINA GAS Ø8	GAS COOK. ASSEMBLY CTRL Ø8	2	4	6	4	6
12	U015010000	DISTRIBUIDOR COMPLET. CG9-20	COMPL. DISTRIBUTOR CG9-20	1				
12	U025042000	DISTRIBUIDOR COMPLET. CG9-40	COMPL. DISTRIBUTOR CG9-40		1			
12	U075004000	DISTRIBUIDOR COMPLET. CG9-60	COMPL. DISTRIBUTOR CG9-60			1		
12	U025039000	DISTRIBUIDOR COMPLET. CG9-41	COMPLETE DISTRIBUTOR CG9-41				1	
12	U035004000	DISTRIBUIDOR COMPLET. CG9-61	COMPLETE DISTRIBUTOR CG9-61					1
13	U202103000	MANGUITO REDUCCION 1/2-3/8"	REDUCTION HOSE 1/2-3/8"				2	2
13A	12010057	ARANDELA 23,5X17,60X1,5	WASHER 23,5X17,60X1,5				2	2
14	S113034000	PIEZOELECTRICO	PIEZOELECTRIC				1	1
14	12043897	PIEZOELECTRICO COMPLETO	COMPLETE PIEZOELECTRIC				1	1
S/Nº	12043907	ANILLO ADAPTADOR	ADAPTER RING				1	1
15	U322118000	PILOTO COMPLETO 100.062	COMPLETE PILOT LIGHT 100,062				1	1
S/Nº	X022131000	BUJIA	SPARK PLUG				1	1
S/Nº	U442137000	INYECTOR Ø 0,4 GN	INJECTOR Ø 0.4 GN.				1	1
S/Nº	U562130000	TERMOPAR L=850	THERMOCOUPLE L=850				1	1
16	12009530	VALVULA MINISIT 0710.654	VALVE MINISIT 0710.654				1	1
16A	12010282	JUNTA TORICA 25,4x20,2x2,6	O-RING 25.4x20.2x2.6				2	2
16B	12008789	MANDO NEGRO MINI 916.124	BLACK CTRL. MINI 916.124				1	1
16C	12008932	CUBIERTA MINISIT 903.052	COVER MINISIT 903.052				1	1
16D	12008944	RACOR 3/8 906.252	CONNECTION 3/8 906.252				2	2
17	U025062000	TUBO PILOTO EUROSIT QUEM.	PILOT PIPE EUROSIT BURNER				1	1
17	U105008000	TUBO PILOTO HORNO	PILOT PIPE BURNER					
S/Nº	12008715	RACORD BICONO 6 958.031	BICONE CONNECTION 6 958.031				2	2
18	U025061000	TUBO COMPLETO EUROSIT QUEMA.	COMPLETE PIPE EUROSIT BURNER				1	1
18	U105002000	TUBO COMPLETO QUEMADOR	COMPLETE PIPE BURNER					
19	U025050000	ENTRADA MINISIT COMPL CG900	INPUT MINISIT COMPL CG900				1	1



Зип Общепит

vsezip.ru

+7(812)987-08-81

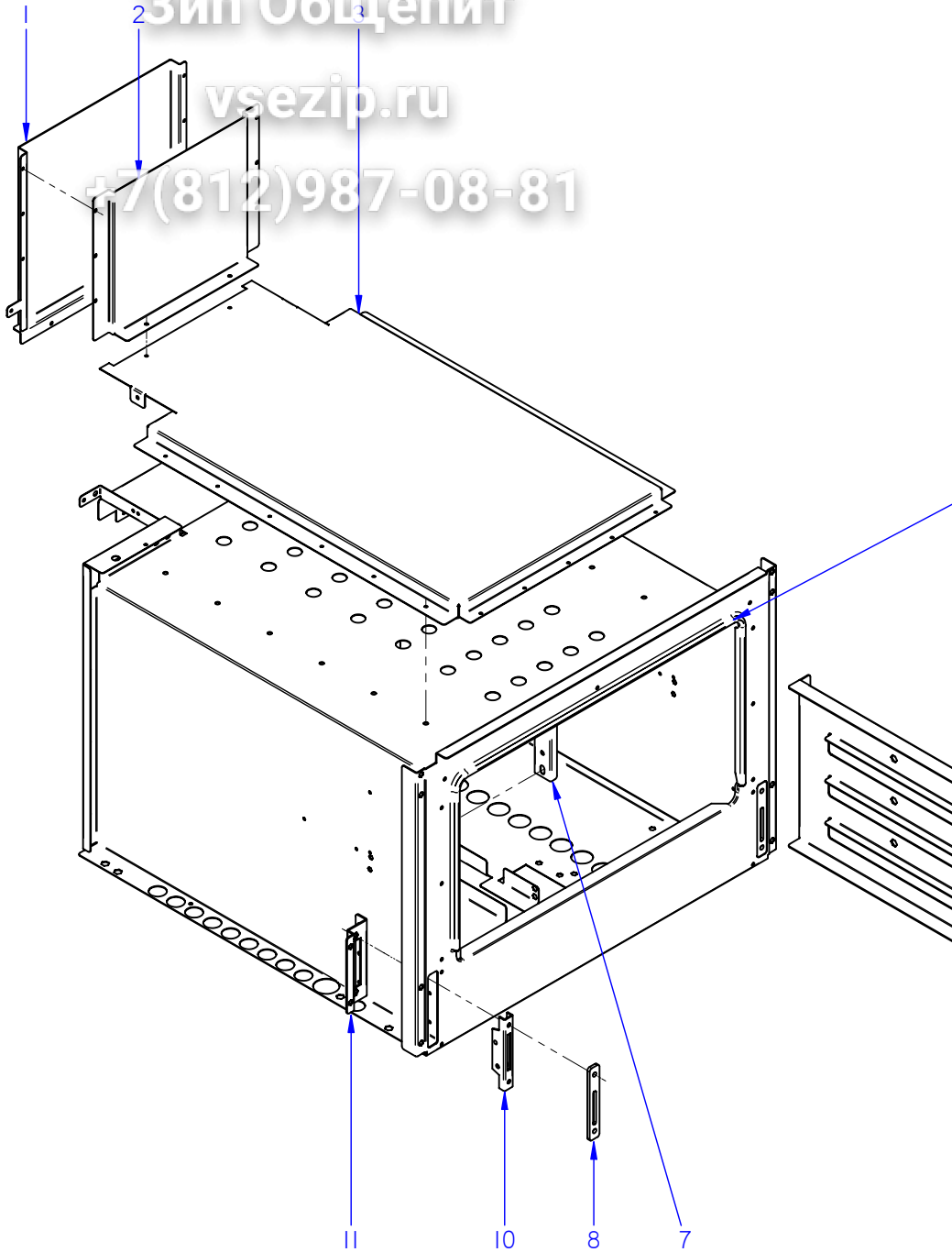

ITEM MARCADO EN COLOR = REPUESTO RECOMENDADO  
COLOURED ITEM = RECOMMENDED SPARE PART

N plano	Firma	Fecha	Aparato	HORNO	Lamina	Fagor Industrial S. Coop. <b>FAGOR</b> Orre
C-2346	<i>(Firma)</i>	2009-06	COCINA CG9-41 / CG9-61 / CG9-82		7	

MOD.		COCINAS		ZONA		HORNO / OVEN		
ITEM	CODIGO	DENOMINACION	TEXTO	CG9-41	CG9-61	CG9-82		
1	U025638000	POSTERIOR CHIMENEA G900	REAR FLUEPIPE G900	1	1	2		
	Q419005000	REMACHE 4x8 ALMG3 / ALUMINIO	RIVET 4X8 ALMG3 / ALUMINIUM	14	14	28		
2	U025637000	CHIMENEA ANTERIOR G900	FRONT FLUEPIPE G900	1	1	2		
3	U022615000	CAMARA DE HUMOS G900	SMOKE CHAMBER G900	1	1	2		
	Q419005000	REMACHE 4x8 ALMG3 / ALUMINIO	RIVET 4X8 ALMG3 / ALUMINIUM	19	19	38		
4	U025623000	JUNTA PUERTA HORNO INOX.	OVEN DOOR SEAL INOX.	1	1	2		
4	U965613000	JUNTA HORNO FIBRA DE VIDRIO	FURNACE FIBERGLASS BOARD	1	1	2		
5	U915607000	GUIA LATERAL HORNO G700	OVEN SIDE GUIDE G700	2	2	4		
	Q151336000	TORNILLO SOPORTE GUIAS	GUIDE SUPPORT BOLT	4	4	8		
	Q302022000	ARANDELA 16X6X1.2 A.304	WASHER 16X6X1.2 A.304	4	4	8		
	Q221321000	REMACHE ROSCAD.NUTSERT.M6	THREADED RIVET .NUTSERT.M6	4	4	8		
6	U915616000	SUPLEMENTO AMARRE GUIA LAT.	SIDE GUIDE FAST. SUPPL.	2	2	4		
	Q412000000	REMACHE TUBULAR 4x8	TUBULAR RIVET 4x8	6	6	12		
7	U055644000	FIJACION BULBO	FASTENING BULB	1	1	2		
	Q412000000	REMACHE TUBULAR 4x8	TUBULAR RIVET 4x8	2	2	4		
8	U915619000	EMBELLECED GUIA BISAGRA	HINGE GUIDE TRIM	2	2	4		
	Q152045000	TORNILLO AMARRE M6X25	FASTENING BOLT M6X25	4	4	4		
10	U010512000	GUIA DE BISAGRA	HINGE GUIDE	2	2	4		
10	12041846	GUIA BISAGRA G700 Y G900	HINGE GUIDE G700 Y G900	2	2	4		
11	U915604000	AMARRE GUIA BISAGRA HORNO	OVEN HINGE GUIDE FASTENING	2	2	4		
	Q221342000	REMACHE EXAGONAL M5	HEXAGONAL RIVET M5	2	2	4		
	Q412000000	REMACHE TUBULAR 4x8	TUBULAR RIVET 4x8	6	6	12		
	Q222042000	REMACHE EXAGONAL ROSCA M6	HEXAGONAL RIVET THREAD M6	4	4	8		

Зип Общежит

vsezip.ru

+7(812)987-08-81

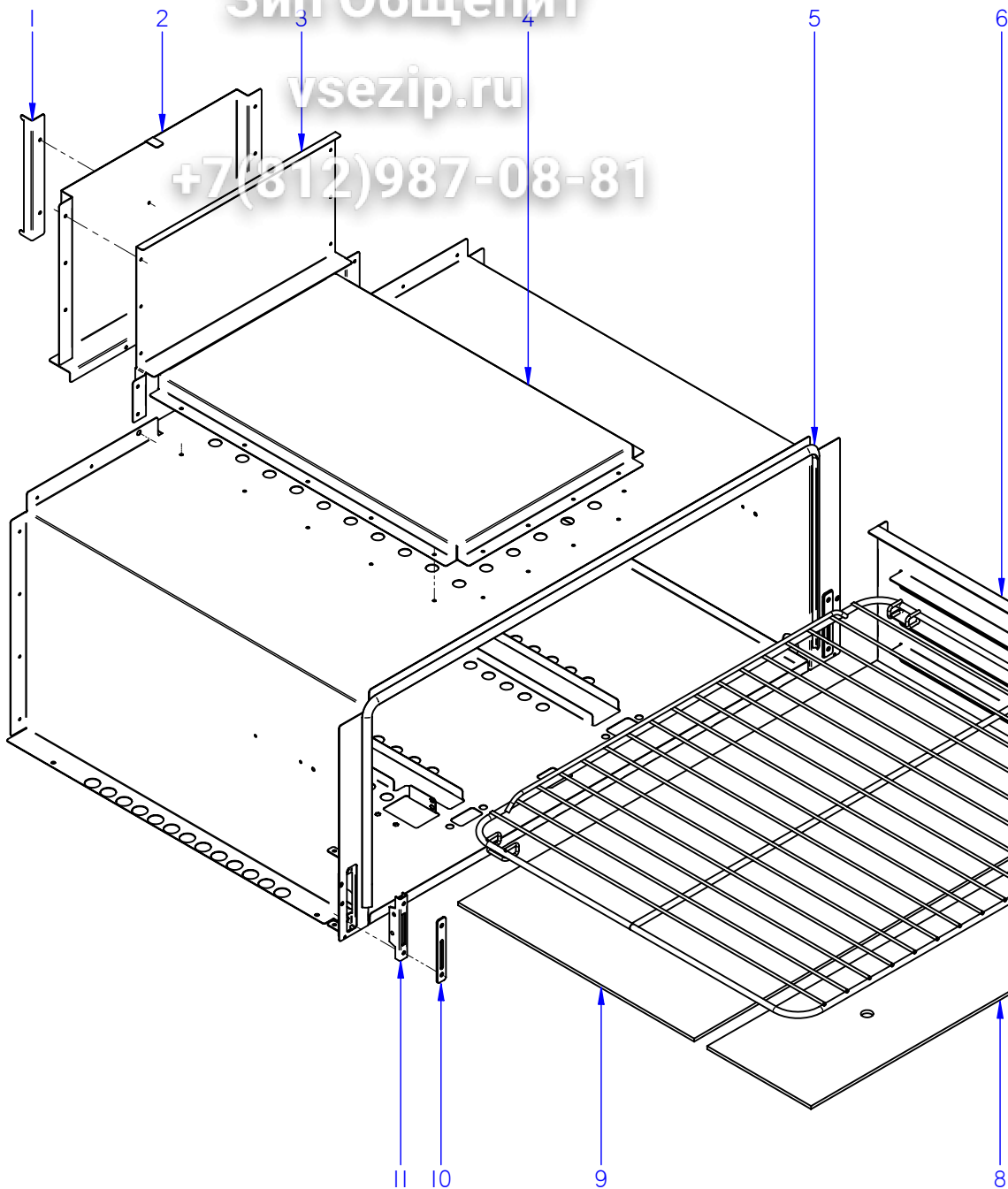

ITEM MARCADO EN COLOR = REPUESTO RECOMENDADO  
COLOURED ITEM = RECOMMENDED SPARE PART

N plano	Firma	Fecha	Aparato	HORNO	Lamina	Fagor Industrial S. Coop. <b>FAGOR</b> Ortze
C-2347		2009-06	COCINA CG9-61 OP		8	

ITEM	CODIGO	DENOMINACION	TEXTO	CG9-61 OP				
1	U105627000	DISTANCIA POSTER. CHIMENEA	REAR DISTANCE FLUEPIPE	1				
	Q412000000	REMACHE TUBULAR 4 x 8	TUBULAR RIVET 4 x 8	2				
2	U105616000	CHIMENEA PARTE EXTERIOR(HG)	EXTERIOR PART FLUEPIPE (HG)	1				
3	U105617000	CHIMENEA PARTE INTERIOR(HG)	INTERIOR PART FLUEPIPE (HG)	1				
	Q412000000	REMACHE TUBULAR 4 x 8	TUBULAR RIVET 4 x 8	14				
4	U105615000	CAMARA HUMOS HORNO (HG )	OVEN SMOKE CHAMBER (HG )	1				
	Q412000000	REMACHE TUBULAR 4 x 8	TUBULAR RIVET 4 x 8	17				
5	U105605000	JUNTA PUERTA HORNO INOX	OVEN DOOR SEAL INOX.	1				
5	12039240	JUNTA HORNO PANORAMICO	PANORAMIC OVEN BOARD	1				
6	U105611000	GUIA LATERAL HORNO(HG)	OVEN SIDE GUIDE (HG)	2				
	Q151336000	TORNILLO SOPORTE GUIAS	GUIDE SUPPORT BOLT	4				
	Q222042000	REMACHE EXAGONAL ROSCA M6	HEXAGONAL RIVET THREAD M6	4				
	Q042043000	TORNILLO AVELLANADO M6X20	COUNTERSUNK BOLT M6x20	4				
7	U105624000	PARRILLA COMPLETA HG	COMPLETE GRILLE HG	1				
8	U105614000	SOLERA PEQUEÑA HORNO ( HG )	SMALL OVEN FLOOR ( HG )	1				
9	U105613000	SOLERA HORNO GRANDE G 700	LARGE OVEN FLOOR G 700	1				
10	U105620000	EMBELLECEDOR GUIA BISAGRA	HINGE GUIDE TRIM	2				
	Q152045000	TORNILLO AMARRE M6X25	FASTENING BOLT M6X25	4				
11	U010512000	GUIA DE BISAGRA	HINGE GUIDE	2				
11	12041846	GUIA BISAGRA G700 Y G900	HINGE GUIDE G700 Y G900	2				

Зип Общепит

vsezip.ru

+7(812)987-08-81

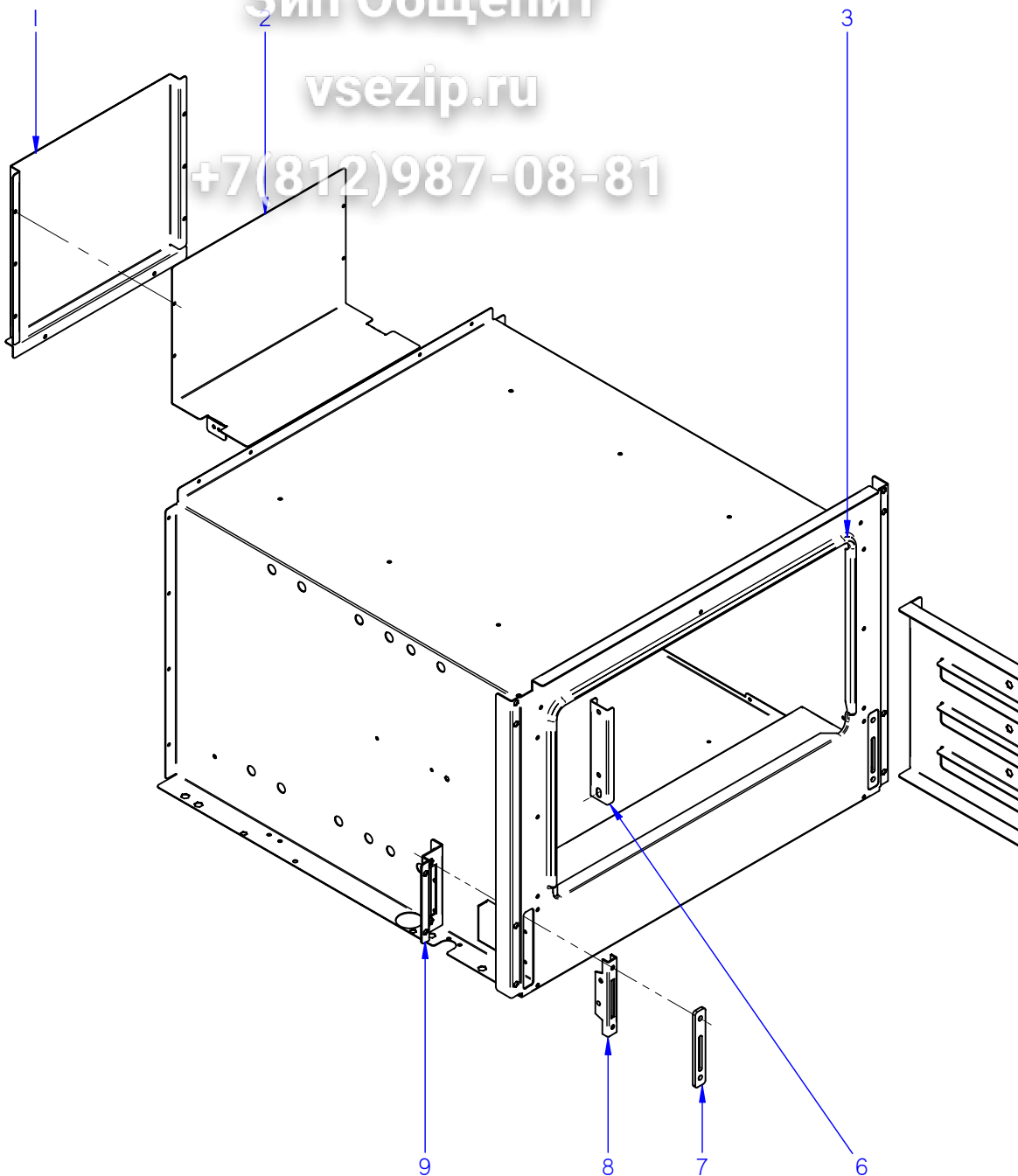

ITEM MARCADO EN COLOR = REPUESTO RECOMENDADO  
COLOURED ITEM = RECOMMENDED SPARE PART

N plano	Firma	Fecha	Aparato	HORNO	Lamina	Fagor Industrial S. Coop. <b>FAGOR</b> Orste
C-2348	<i>(Firma)</i>	2009-06	COCINA GEE9-41		9	

MOD.	COCINAS	ZONA	HORNO / OVEN					
ITEM	CODIGO	DENOMINACION	TEXTO	CGE9-41				
1	U675614000	POSTERIOR CHIMENEA CGE9-41	REAR FLUEPIPE CGE9-41	1				
	Q419005000	REMACHE 4x8 ALMG3 / ALUMINIO	RIVET 4X8 ALMG3 / ALUMINIUM	16				
2	U675615000	ANTERIOR DE CHIMENEA CGE9-41	FRONT FLUEPIPE CGE9-41	1				
3	U025623000	JUNTA PUERTA HORNO INOX.	OVEN DOOR SEAL INOX.	1				
3	U965613000	JUNTA HORNO FIBRA DE VIDRIO	FURNACE FIBERGLASS BOARD	1				
4	U915607000	GUIA LATERAL HORNO G700	OVEN SIDE GUIDE G700	2				
	Q151336000	TORNILLO SOPORTE GUIAS	GUIDE SUPPORT BOLT	4				
	Q302022000	ARANDELA 16X6X1.2 A.304	WASHER 16X6X1.2 A.304	4				
	Q221321000	REMACHE ROSCAD.NUTSERT.M6	THREADED RIVET .NUTSERT.M6	4				
5	U915616000	SUPLEMENTO AMARRE GUIA LAT.	SIDE GUIDE FAST. SUPPL.	2				
	Q412000000	REMACHE TUBULAR 4x8	TUBULAR RIVET 4x8	6				
6	U055644000	FIJACION BULBO	FASTENING BULB	1				
	Q412000000	REMACHE TUBULAR 4x8	TUBULAR RIVET 4x8	2				
7	U915619000	EMBELLECED GUIA BISAGRA	HINGE GUIDE TRIM	2				
	Q152045000	TORNILLO AMARRE M6X25	FASTENING BOLT M6X25	4				
8	U010512000	GUIA DE BISAGRA	HINGE GUIDE	2				
8	12041846	GUIA BISAGRA G700 Y G900	HINGE GUIDE G700 Y G900	2				
9	U915604000	AMARRE GUIA BISAGRA HORNO	OVEN HINGE GUIDE FASTENING	2				
	Q221342000	REMACHE EXAGONAL M5	HEXAGONAL RIVET M5	2				
	Q412000000	REMACHE TUBULAR 4x8	TUBULAR RIVET 4x8	6				
	Q222042000	REMACHE EXAGONAL ROSCA M6	HEXAGONAL RIVET THREAD M6	4				

Зип Общепит

vsezip.ru

+7(812)987-08-81

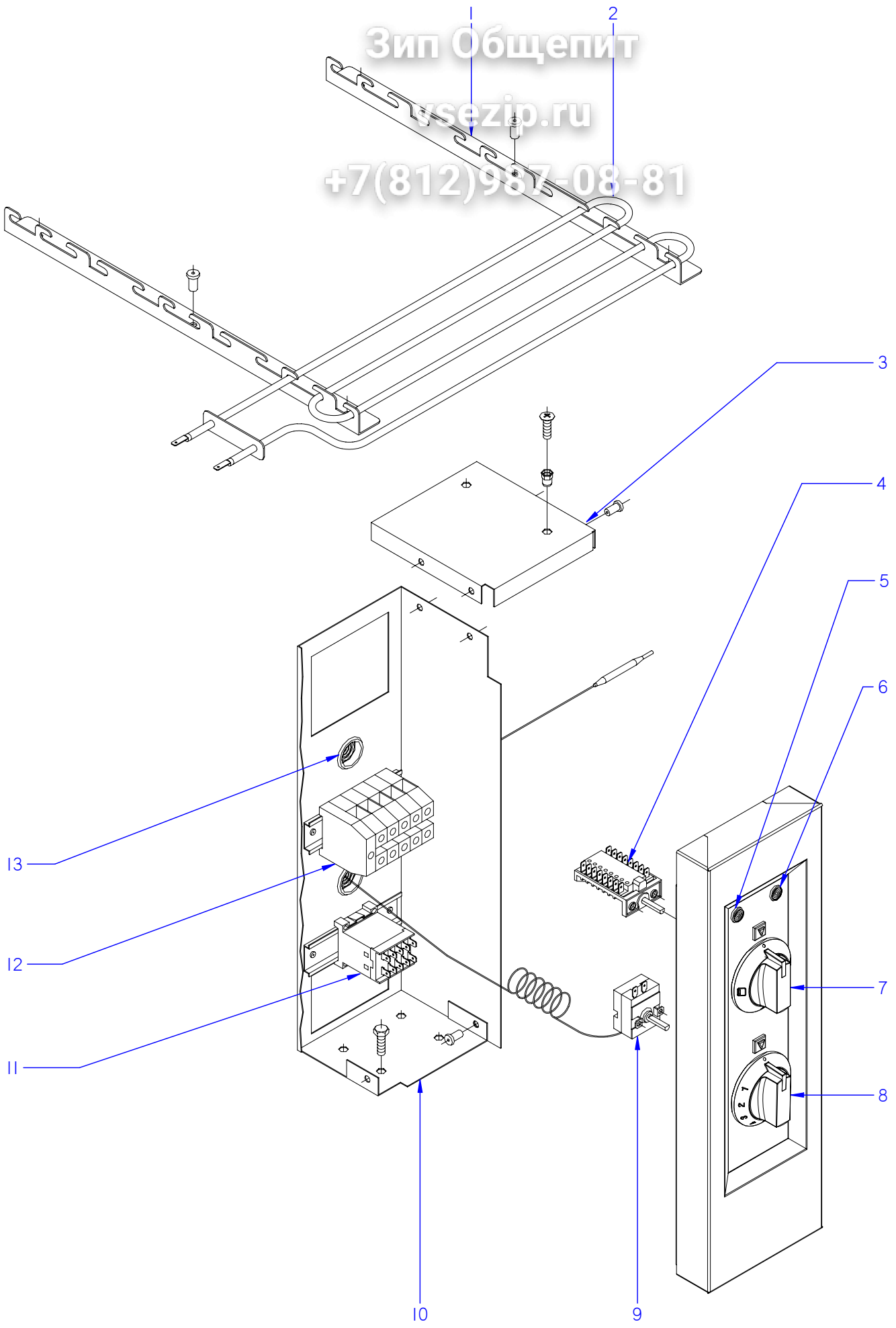

ITEM MARCADO EN COLOR = REPUESTO RECOMENDADO  
COLOURED ITEM = RECOMMENDED SPARE PART

N plano	Firma	Fecha	Aparato	CONJUNTO FUNCIONAL ELECTRICO	Lamina	Fagor Industrial S.Coop. <b>FAGOR</b>
C-2349	<i>[Signature]</i>	2009-06	COCINA CGE9-41		10	Oñate

MOD.		COCINAS		vsezip.ru		CONJUNTO FUNCIONAL ELECTRICO	
ITEM	CODIGO	DENOMINACION	TEXTO	CGE9-41			
1	U805613000	ESCUADRA SOPOR. RESISTENCIAS	SUPP. BRACKET RESISTORS	4			
	Q419005000	REMACHE 4x8 ALMG3 / ALUMINIO	RIVET 4X8 ALMG3 / ALUMINIUM	12			
2	U803004000	RESISTENCIA 1000W/230V	RESISTOR 1000W -230V	6			
3	U673051000	TAPA DE CUADRO ELECTRICO	ELECTRIC PANEL COVER	1			
	Q419005000	REMACHE 4x8 ALMG3 / ALUMINIO	RIVET 4X8 ALMG3 / ALUMINIUM	4			
	Q419005000	REMACHE 4x8 ALMG3 / ALUMINIO	RIVET 4X8 ALMG3 / ALUMINIUM	2			
	Q221342000	REMACHE EXAGONAL M5	HEXAGONAL RIVET M5	2			
	Q012032000	TORNILLO EXAGONAL M5x15 A304	HEXAGONAL BOLT M5x15	2			
	Q012032000	TORNILLO EXAGONAL M5x15 A304	HEXAGONAL BOLT M5x15	2			
4	U673006000	CONMUTADOR	SWITCH	1			
	Q151320000	TORNILLO ALOMADO M4x6 H.ZINC.	CURVED SCREW M4X6 H. ZINC	2			
5	R693055000	PILOTO VERDE 41227000C7	GREEN PILOT 41227000C7	1			
5	12047390	PILOTO VERDE 230V AC 8KW 16MM	GREEN PILOT 230V AC 8KW 16MM	1			
6	R693056000	PILOTO AMBAR	AMBER PILOT	1			
6	12024669	PILOTO AMBAR Ø18	AMBER PILOT Ø18	1			
7	U173006000	MANDO MONTADO CE Ø6	CONTROL CE Ø6	1			
8	U173005000	MANDO CE Ø6 TERMOSTATO	CONTROL Ø6 THERMOSTAT	1			
9	X153000000	TERMOSTATO 50-310° C	THERMOSTAT 50-310 C	1			
	Q151320000	TORNILLO ALOMADO M4x6 H.ZINC.	CURVED SCREW M4X6 H. ZINC	2			
10	U673050000	CUADRO ELECTRICO	ELECTRICAL PANEL	1			
11	Z213007000	CONTACTOR 3TF2010-3AL2	CONTACTOR 3TF2010-3AL2	1			
	R663055000	GUIA CONTACTOR L-120	CONTACTOR GUIDE L-120	1			
	Q419005000	REMACHE 4x8 ALMG3 / ALUMINIO	RIVET 4X8 ALMG3 / ALUMINIUM	4			
12	P453025000	BORNES 10 WDU-10203.0	TERMINALS 10 WDU-10203.0	3			
	U803009000	BORNA PASO AZUL 16 MM.	BLUE TAP TERMINAL 16MM	1			
	Z263302000	BORNA NEUTRO AZUL 57A 10mm	BLUE NEUTRAL TERMINAL 57A	1			
	P453026000	BORNA TIERRA 10 WPE-10103.0	TERMINAL TIER 10 WPE-10103.0	1			
	Z263303000	TOPE FINAL	END STOP	1			
	R663055000	GUIA CONTACTOR L-120	CONTACTOR GUIDE L-120	1			
13	X723014000	PASAMUROS AMETRO 30		2			





# Зип Общепит

MOD.		COCINAS	ZONA	PIEZAS ESPECIFICAS PARA LA VERSION AUSTRALIA				
ITEM	CODIGO	DENOMINACION	TEXTO	CG9-2000	CG9-40 A	CG9-60 A	CG9-41 A	CG9-61 A
		<b>PIEZAS A ELIMINAR</b>	<b>PARTS TO BE REMOVED</b>					
2	U112402000	TOBERA Ø 2,10 GN (8000)	NOZZLE Ø 2,10 GN (8000)	1	1	2	1	2
8	U112401000	TOBERA Ø 1,55 BP (10500)	NOZZLE Ø 1.55 BP (10500)	1	1	1	1	1
8	631600000	TOBERA Ø 2,40 GN (10500)	NOZZLE Ø 2.40 GN (10500)	1	1	1	1	1
9	U235706000	VENTURI 10.500	VENTURI 10,500	1	1	1	1	1
10	U025706000	REGULADOR DE AIRE 10.000	AIR CONTROL 10.000	1	1	1	1	1
12	U235701500	DIFUSOR 10.500 Kcal/H	DIFFUSER 10.500 Kcal/H	1	1	1	1	1
12	12047137	DIFUSOR 10.500 (AGUJ Y PINTA)	DIFFUSER 10.500	1	1	1	1	1
14	U025712000	PROTEC. PILOTO QUEMAD. 4000	BURNER PILOT GUARD 4000	1	2	3	2	3
15	U445731500	QUEMADOR 4000 (00545-010)	BURNER 4000 (00545-010)	1	2	3	2	3
16	U025709000	CUERPO QUEMADOR 4000Kcal/H	BURNER BODY 4000 Kcal/H	1	2	3	2	3
18	U125720000	VENTURI QUEMADOR 4000 kcl	VENTURI BURNER 4000 kcl	1	2	3	2	3
19	X312400000	TOBERA Ø 1,10 BP (4000)	NOZZLE Ø 1.10 BP (4000)	1	2	3	2	3
19	R302400000	TOBERA Ø 1,65 GN (4000)	NOZZLE Ø 1.65 GN (4000)	1	2	3	2	3
S/Nº	U022620000	POSICIONADOR PORTATOB. G900	NOZZLE-HOLDER POSITION. G900	1	1	1	1	1
10	U912115000	GRIFO 18700 BY-PASS 0,75	TAP 18700 BY-PASS 0.75	1	2	3	2	3
10	U912117000	GRIFO 18700 BY-PASS 1,45	TAP 18700 BY-PASS 1.45	1	1	1	1	1
		<b>PIEZAS A INTRODUCIR</b>	<b>PARTS TO BE INCLUDED</b>					
2	631000000	TOBERA Ø 1,40 BP (8000)	NOZZLE Ø 1.40 BP (8000)	1	3	4	3	4
2	U054400000	TOBERA Ø 2,50 GN (8000)	NOZZLE Ø 2,50 GN (8000)	1	4	6	4	6
3	U565700000	VENTURI QUEMADOR 8000	VENTURI BURNER 8000	1	3	4	3	4
4	U265702000	REGULADOR AIRE	AIR CONTROLLER	1	1	1	1	1
5	U025710000	CUERPO QUEMADOR 8000 Kcal/H	BURNER BODY 8000 Kcal/h	1	3	4	3	4
6	U915703000	PROTEC. PILOTO QUEMAD. 7000	BURNER PILOT GUARD 7000	1	2	3	2	3
7	U135702500	QUEMADOR 8000	BURNER 8000	1	3	4	3	4
4	U022619000	POSICIONADOR PORTATOB. 4000	NOZZLE-HOLDER POSITION. 4000	1	1	1	1	1
10	U912109000	GRIFO 18700 BY-PASS 1,15	TAP 18700 BY-PASS 1.15	1	3	4	3	4

# Зип Общепит

<b>MOD.</b>	<b>COCINAS</b>	<b>ZONA</b>	<b>PIEZAS ESPECIFICAS PARA LA VERSION ITALIA</b>
-------------	----------------	-------------	--

ITEM	CODIGO	DENOMINACION	TEXTO	CG9-40 I	CG9-60 I	CG9-41 I	CG9-61 I	CG9-82 I
		<b><u>PIEZAS A ELIMINAR</u></b>	<b><u>PARTS TO BE REMOVED</u></b>					
6	U915703000	PROTEC. PILOTO QUEMAD. 7000	BURNER PILOT GUARD 7000	1	1	1	1	2
8	U112401000	TOBERA Ø 1,55 BP (10500)	NOZZLE Ø 1.55 BP (10500)	1	1	1	1	2
8	631600000	TOBERA Ø 2,40 GN (10500)	NOZZLE Ø 2.40 GN (10500)	1	1	1	1	2
9	U235706000	VENTURI 10.500	VENTURI 10,500	1	1	1	1	2
10	U025706000	REGULADOR DE AIRE 10.000	AIR CONTROL 10.000	1	1	1	1	2
11	U025711000	CUERPO QUEMADOR 10.000Kcal/H	BURNER BODY 10,000 Kcal/H	1	1	1	1	2
12	U235701500	DIFUSOR 10.500 Kcal/H	DIFFUSER 10.500 Kcal/H	1	1	1	1	2
12	12047137	DIFUSOR 10.500 (AGUJ Y PINTA)	DIFFUSER 10.500	1	1	1	1	2
S/Nº	U022620000	POSICIONADOR PORTATOB. G900	NOZZLE-HOLDER POSITION. G900	1	1	1	1	2
10	U912117000	GRIFO 18700 BY-PASS 1,45	TAP 18700 BY-PASS 1.45	1	1	1	1	2
		<b><u>PIEZAS A INTRODUCIR</u></b>	<b><u>PARTS TO BE INCLUDED</u></b>					
14	U025712000	PROTEC. PILOTO QUEMAD. 4000	BURNER PILOT GUARD 4000	—	1	—	1	—
15	U445731500	QUEMADOR 4000 (00545-010)	BURNER 4000 (00545-010)	1	1	1	1	2
16	U025709000	CUERPO QUEMADOR 4000Kcal/H	BURNER BODY 4000 Kcal/H	1	1	1	1	2
18	U125720000	VENTURI QUEMADOR 4000 kcl	VENTURI BURNER 4000 kcl	1	1	1	1	2
19	X312400000	TOBERA Ø 1,10 BP (4000)	NOZZLE Ø 1.10 BP (4000)	1	1	1	1	2
19	R302400000	TOBERA Ø 1,65 GN (4000)	NOZZLE Ø 1.65 GN (4000)	1	1	1	1	2
4	U022619000	POSICIONADOR PORTATOB. 4000	NOZZLE-HOLDER POSITION. 4000	1	1	1	1	2
10	U912115000	GRIFO 18700 BY-PASS 0,75	TAP 18700 BY-PASS 0.75	1	1	1	1	2

# Зип Общепит

MOD.		COCINAS		vsezip.ru		REPUESTOS RECOMENDADOS RECOMMENDED SPARE PART				
ITEM	CODIGO	DENOMINACION	TEXTO	CG9-20	CG9-40	CG9-60	CG9-41	CG9-61		
17	U020528000	BISAGRA CIERRE HORNO	OVEN LOCK HINGE	—	—	—	2	2		
5	12005260	PILOTO COMPL. COCINAS 1 LLAM	1 FLAME COMPLETE PILOT	2	4	6	4	6		
S/Nº	U442137000	INYECTOR Ø 0,4 GN	INJECTOR Ø 0.4 GN.	2	4	6	4	6		
6	U222130000	TERMOPAR L=600	THERMOCOUPLE L=600	1	2	3	—	—		
S/Nº	U262130000	TERMOPAR L=1000	THERMOCOUPLE L=1000	1	2	3	—	—		
10	U912115000	GRIFO 18700 BY-PASS 0,75	TAP 18700 BY-PASS 0.75	1	2	3	—	—		
10	U912109000	GRIFO 18700 BY-PASS 1,15	TAP 18700 BY-PASS 1.15	1	1	2	—	—		
10	U912117000	GRIFO 18700 BY-PASS 1,45	TAP 18700 BY-PASS 1.45	—	1	1	—	—		
6	U222130000	TERMOPAR L=600	THERMOCOUPLE L=600	—	—	—	2	3		
S/Nº	U262130000	TERMOPAR L=1000	THERMOCOUPLE L=1000	—	—	—	2	3		
10	U912115000	GRIFO 18700 BY-PASS 0,75	TAP 18700 BY-PASS 0.75	—	—	—	2	3		
10	U912109000	GRIFO 18700 BY-PASS 1,15	TAP 18700 BY-PASS 1.15	—	—	—	1	2		
10	U912117000	GRIFO 18700 BY-PASS 1,45	TAP 18700 BY-PASS 1.45	—	—	—	1	1		
14	12043897	PIEZOELECTRICO COMPLETO	COMPLETE PIEZOELECTRIC	—	—	—	1	1		
S/Nº	12043907	ANILLO ADAPTADOR	ADAPTER RING	—	—	—	1	1		
15	U322118000	PILOTO COMPLETO 100.062	COMPLETE PILOT LIGHT 100,062	—	—	—	1	1		
S/Nº	U442137000	INYECTOR Ø 0,4 GN	INJECTOR Ø 0.4 GN.	—	—	—	1	1		
S/Nº	U562130000	TERMOPAR L=850	THERMOCOUPLE L=850	—	—	—	1	1		
16	12009530	VALVULA MINISIT 0710.654	VALVE MINISIT 0710.654	—	—	—	1	1		
16B	12008789	MANDO NEGRO MINI 916.124	BLACK CTRL. MINI 916.124	—	—	—	1	1		
4	U965613000	JUNTA HORNO FIBRA DE VIDRIO	FURNACE FIBERGLASS BOARD	—	—	—	1	1		
10	12041846	GUIA BISAGRA G700 Y G900	HINGE GUIDE G700 Y G900	—	—	—	2	2		
5	U105605000	JUNTA PUERTA HG (INOX)	HG DOOR SEAL INOX.	—	—	—	—	—		
11	12041846	GUIA BISAGRA G700 Y G900	HINGE GUIDE G700 Y G900	—	—	—	—	—		
3	U965613000	JUNTA HORNO FIBRA DE VIDRIO	FURNACE FIBERGLASS BOARD	—	—	—	—	—		
8	12041846	GUIA BISAGRA G700 Y G900	HINGE GUIDE G700 Y G900	—	—	—	—	—		
2	U803004000	RESISTENCIA 1000W/230V	RESISTOR 1000W -230V	—	—	—	—	—		
4	U673006000	CONMUTADOR	SWITCH	—	—	—	—	—		
5	12047390	PILOTO VERDE 230V AC 8KW 16MM	GREEN PILOT 230V AC 8KW 16M	—	—	—	—	—		
6	12024669	PILOTO AMBAR Ø18	AMBER PILOT Ø18	—	—	—	—	—		

