

Зип Общепит

vsezip.ru

---

DESPIECE TECNICO

---

+7(812)987-08-81

**Hornos a gas**  
**Fours à gaz**  
**Gas ovens**  
**Gas heissluftdämpfer**  
**Forni a gas**  
**Fornos a gás**

**Modelos:**

**COG-201**

**VG-201**

**VPG-201**

***Diciembre 2010 December***

***Revisado Octubre 2012 / Revised October 2012***

**FAGOR** 

---

F A G O R I N D U S T R I A L

Зип Общепит

vsezip.ru

+7(812)987-08-81

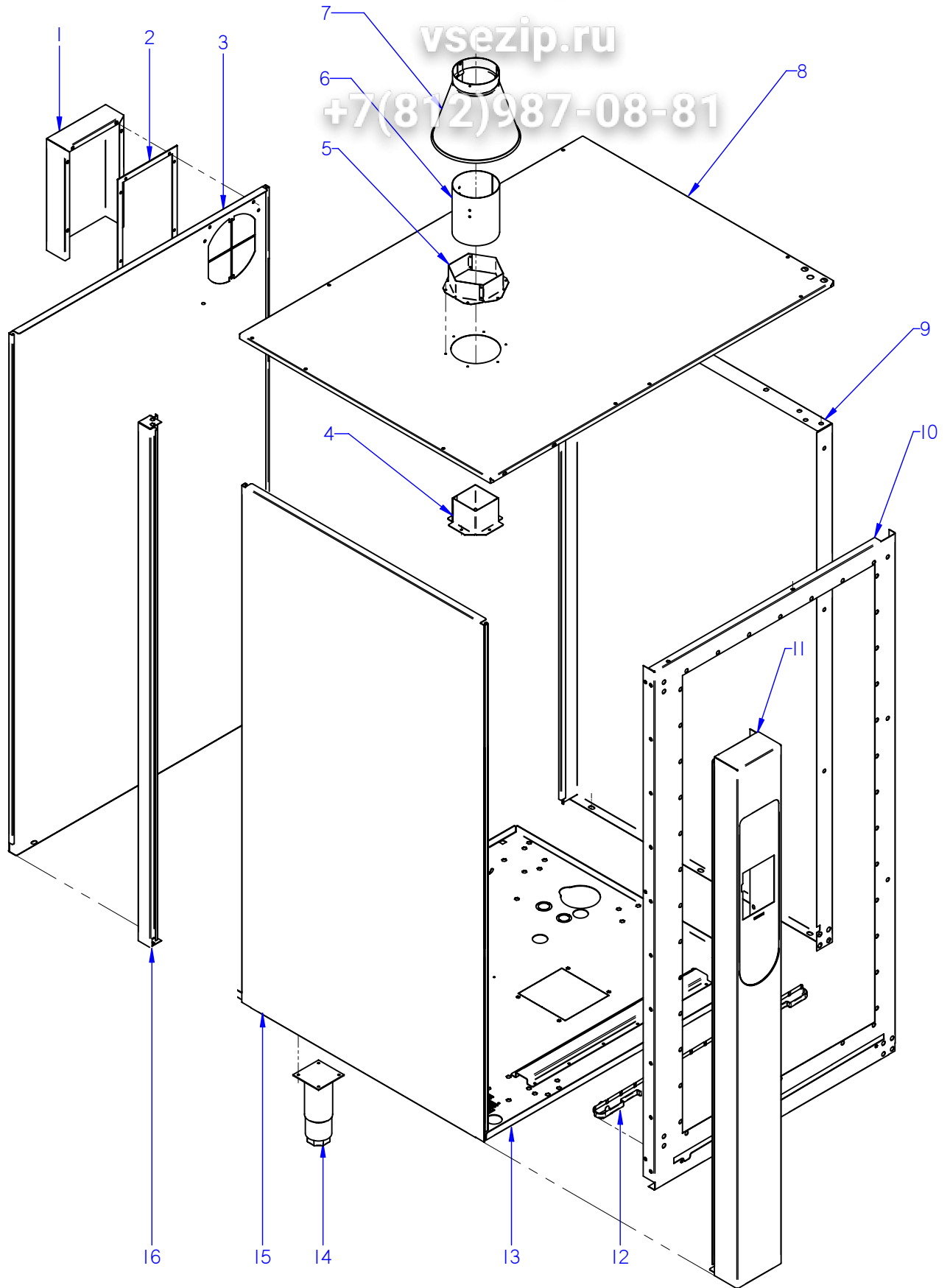

ITEM MARCADO EN COLOR = REPUESTO RECOMENDADO  
COLOURED ITEM = RECOMMENDED SPARE PART

N plano	Firma	Fecha	Aparato	MUEBLE / UNIT	Lamina	Fagor Industrial S.Coop. <b>FAGOR</b>
C-2750	<i>[Signature]</i>	2010-12		HORNOS COG-201	1	Oñate

MOD.	HORNOS / OVEN	ZONA / ZONE	MUEBLE / UNIT				
ITEM	CODIGO	DENOMINACION	TEXTO	COG-201			
1	T512807500	CHAPA SEPARACION IPX5 20	SEPARATION PLATE IPX5 20	1			
	Q221342000	REMACHE EXAGONAL M5	HEXAGONAL RIVET M.5	4			
	Q232030000	ARANDELA A5	WASHER A.5	4			
	Q242030000	ARANDELA ABANICO A5 A.304	FAN SHAPED WASHER A.5	4			
	Q012031000	TORNILLO EXAGONAL M5x10 A304	HEXAGONAL SCREW M.5x10	4			
2	T512808000	JUNTA IPX5 20/21	SEAL IPX5 20/21	1			
3	T702804000	PANEL POST. EXTERIOR 20/11	REAR EXTERIOR PANEL 20/11	1			
4	T012605000	CHIMENEA INTERIOR COMPLETA	COMPLETE INTER. FLUEPIPE	1			
	Q412002000	REMACHE TUBULAR Ø4x7.5	TUBULAR RIVET Ø4x7.5	4			
5	T832610000	GUIA CHIMENEA	FLUEPIPE GUIDANCE	2			
	Q412002000	REMACHE TUBULAR Ø4x7.5	TUBULAR RIVET Ø4x7.5	15			
	Q012042000	TORNILLO EXAGONAL M6x15	HEXAGONAL BOLT M6x15	2			
	Q232040000	ARANDELA A6	WASHER A.6	2			
	Q242040000	ARANDELA ABANICO A6 A.304	FAN SHAPED WASHER A.6	2			
6	R292646500	CONDUCTO HUMOS	SMOKE DUCT	1			
7	R272612000	CHIMENEA	FLUEPIPE	1			
S/Nº	R272614000	SOPORTE CHIMENEA HCG/HGC	CHIMNEY SUPPORT	3			
8	T732801000	PANEL SUPERIOR 20/11	SUPERIOR PANEL 20/11	1			
	Q302022000	ARANDELA 16X6X1.2 A.304	FLAT WASHER 16x6x1,2	10			
	Q242040000	ARANDELA ABANICO A6 A.304	FAN SHAPED WASHER A.6	10			
	Q012042000	TORNILLO EXAGONAL M6x15	HEXAGONAL BOLT M6x15	10			
9	T702801000	PANEL DERECHO 20/11	RIGHT PANEL 20/11	1			
10	T722801000	PANEL FRONTAL 20/11	FRONT PANEL 20/11	1			
	Q221342000	REMACHE EXAGONAL M.5	HEXAGONAL RIVET M.5	13			
	Q232040000	ARANDELA A6	WASHER A.6	4			
	Q242040000	ARANDELA ABANICO A6 A.304	FAN SHAPED WASHER A.6	4			
	Q012042000	TORNILLO EXAGONAL M6x15	HEXAGONAL BOLT M6x15	4			
	Q222041000	REMACHE EXAGONAL M.4 INOX.	HEXAGONAL M.4 INOX.	3			
11	T702807000	PANEL PORTAMANDOS HGC-20/11	CONTROL PANEL HGC-20/11	1			
S/Nº	T712806000	JUNTA PORTAMANDOS 10/11	CONTROL SEAL HORZ 10/11	1			
S/Nº	T812810000	JUNTA PORTAMAND. HORZ 10/11	CONTROL HOLDER SEAL 10/11	1			

MOD.		HORNOS / OVEN		ZONA / ZONE		MUEBLE / UNIT	
ITEM	CODIGO	DENOMINACION	TEXTO	COG-201			
12	T722807000	RECOGEAGUAS PLASTICO	PLAST SPRING WATER COLLE.	1			
	Q242020000	ARANDELA ABANICO A4 A.304	FAN SHAPED WASHER A.4	3			
	Q032021000	TORNILLO ALOMADO M4x10	CURVED SCREW M.4x10	3			
13	T712801000	BASE EXTERIOR 20/11	EXTERIOR BASE 20/11	1			
	Q221343000	REMACHE EXAGONAL M.6	HEXAGONAL RIVET M.6	52			
S/Nº	T712803000	REFUERZO BASE 20/11	REINFORCEMENT BASE	1			
	Q412002000	REMACHE AVINOX Ø4X10	AVINOX RIVET Ø4X10	12			
14	X260151000	PATA REGULABLE	REGULABLE LEG	4			
	Q232040000	ARANDELA A6	WASHER A.6	16			
	Q242040000	ARANDELA ABANICO A6 A.304	FAN SHAPED WASHER A.6	16			
	Q012043000	TORNILLO EXAGONAL M6x20	HEXAGONAL BOLT M6x20	16			
15	T702805000	PANEL IZQUIERDO 20/11	LEFT PANEL 10/21	1			
	Q302022000	ARANDELA 16X6X1.2 A.304	FLAT WASHER 16x6x1,2	7			
	Q242040000	ARANDELA ABANICO A6 A.304	FAN SHAPED WASHER A.6	7			
	Q012042000	TORNILLO EXAGONAL M6x15	HEXAGONAL BOLT M6x15	7			
16	T702803000	PANEL CANTONERA	PROTECTOR PANEL	1			

Всип Общепит

vsezip.ru

+7(812)987-08-81

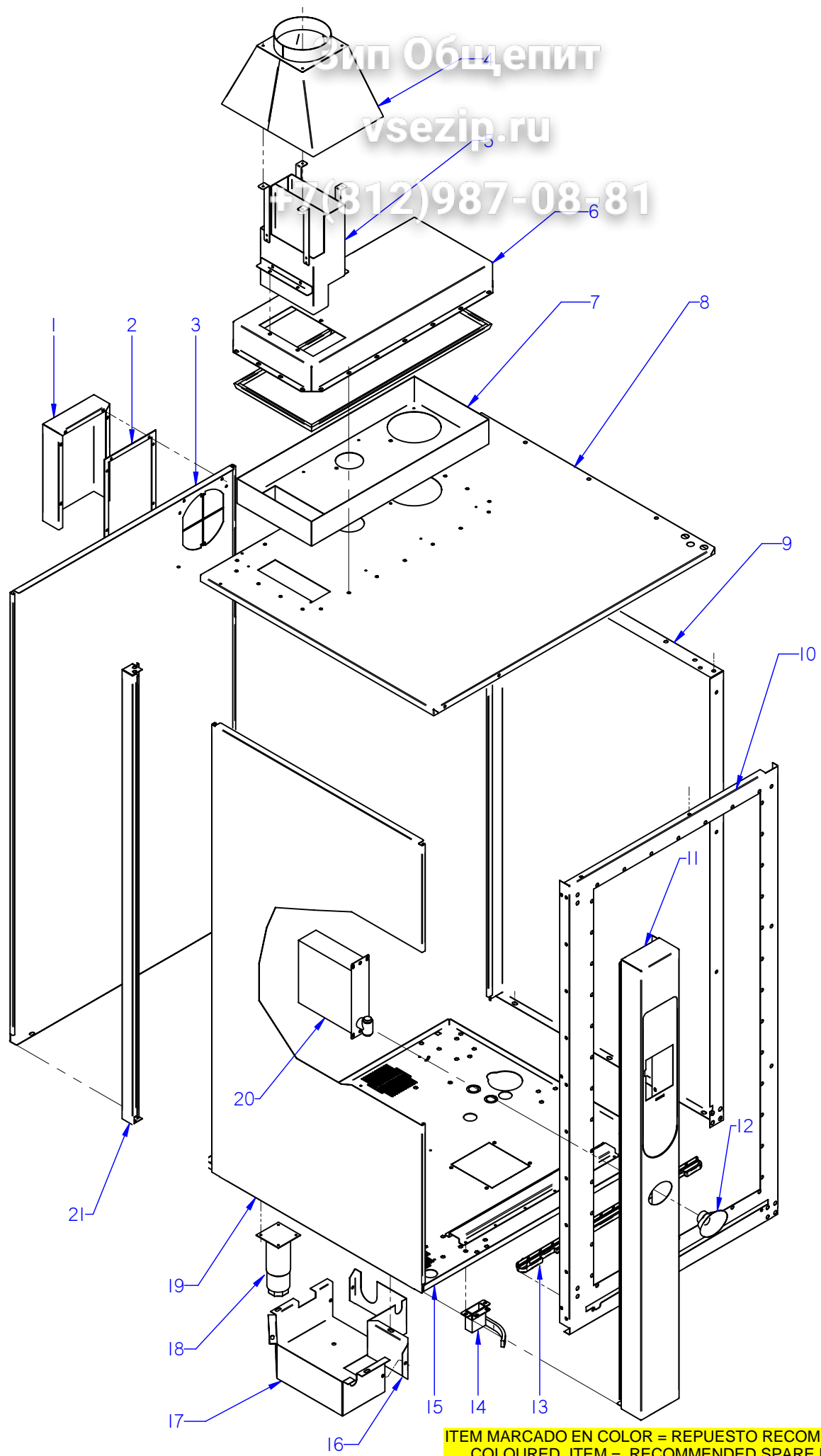

ITEM MARCADO EN COLOR = REPUESTO RECOMENDADO  
COLOURED ITEM = RECOMMENDED SPARE PART

N plano	Firma	Fecha	Aparato	MUEBLE / UNIT	Lamina	Fagor Industrial S.Coop. <b>FAGOR</b>
C-2751	<i>(Signature)</i>	2010-12	HORNOS VG-201 / VPG-201		2	Oñate

+7(812)987-08-81

MOD.	HORNOS / OVEN	ZONA / ZONE	MUEBLE / UNIT					
ITEM	CODIGO	DENOMINACION	TEXTO	VG-201	VPG-201			
1	T512807500	CHAPA SEPARACION IPX5 20	SEPARATION PLATE IPX5 20	1	1			
	Q221342000	REMACHE EXAGONAL M5	HEXAGONAL RIVET M.5	4	4			
	Q232030000	ARANDELA A5	WASHER A.5	4	4			
	Q012031000	TORNILLO EXAGONAL M5x10 A304	HEXAGONAL SCREW M.5x10	4	4			
2	T512808000	JUNTA IPX5 20/21	SEAL IPX5 20/21	1	1			
3	T702804000	PANEL POST. EXTERIOR 20/11	REAR EXTERIOR PANEL 20/11	1	1			
4	T122820000	CHIMENEA EXTERIOR COMPLETA	COMPLETE EXTERIOR FLUEPIPE	1	1			
	Q412002000	REMACHE TUBULAR Ø4x7.5	TUBULAR RIVET Ø4x7.5	12	12			
	Q152004000	TORNILLO APLASTADO M5x13	FLAT HEAD SCREW M5X13	3	3			
5	T122816000	SALIDA DE COLECTOR	MANIFOLD OUTPUT	1	1			
S/Nº	T112815000	SOPORTE DE CHIMENEA	CHIMNEY SUPPORT	4	4			
	Q221342000	REMACHE EXAGONAL M5	HEXAGONAL RIVET M5	8	8			
	Q152004000	TORNILLO APLASTADO M5x13	FLAT HEAD SCREW M5X13	8	8			
6	T752805500	TAPA COLECTOR	TOP MANIFOLD	1	1			
	3715200000	JUNTA CRISTAL	GLASS SEAL	2	2			
7	T752803000	COLECTOR COMPLETO	COMPL. MANIFOLD	1	1			
	Q412002000	REMACHE TUBULAR Ø4x7.5	TUBULAR RIVET Ø4x7.5	8	8			
	Q012042000	TORNILLO EXAGONAL M6X15 A304	HEXAGONAL SCREW M.6X15	8	8			
	Q232040000	ARANDELA A6	WASHER A.6	8	8			
8	T752802000	PANEL SUPERIOR 20/11	SUPERIOR PANEL 20/11	1	1			
	Q302022000	ARANDELA 16X6X1.2 A.304	FLAT WASHER 16x6x1,2	10	10			
	Q242040000	ARANDELA ABANICO A6 A.304	FAN SHAPED WASHER A.6	10	10			
	Q012042000	TORNILLO EXAGONAL M6x15	HEXAGONAL BOLT M6x15	10	10			
9	T742802000	PANEL DERECHO 20/11	RIGHT PANEL 20/11	1	1			
10	T722801000	PANEL FRONTAL 20/11	FRONT PANEL 20/11	1	1			
	Q232040000	ARANDELA A6	WASHER A.6	4	4			
	Q242040000	ARANDELA ABANICO A6 A.304	FAN SHAPED WASHER A.6	4	4			
	Q012042000	TORNILLO EXAGONAL M6x15	HEXAGONAL BOLT M6x15	4	4			
	Q222041000	REMACHE EXAGONAL M.4 INOX.	HEXAGONAL M.4 INOX.	3	3			
11	T742806000	PANEL PORTAMANDOS HGV-20/11	CONTROL PANEL HGV-20/11	1	—			
11	T752806000	PANEL PORTAMANDOS HGP 20-21	CONTROL PANEL HGP 20-21	—	1			

MOD.	HORNOS / OVEN	ZONA / ZONE	MUEBLE / UNIT					
ITEM	CODIGO	DENOMINACION	TEXTO	VG-201	VPG-201			
S/Nº	T712806000	JUNTA PORTAMANDOS 10/11	CONTROL SEAL HORZ 10/11	1	1			
S/Nº	T842814000	JUNTA PORTAMAND. HORZ 10/11	CONTROL HOLDER SEAL 10/11	1	1			
12	T922801000	EMBELLECEDOR DUCHA	SHOWER TRIM	_	1			
13	T722807000	RECOGEAGUAS PLASTICO	PLAST SPRING WATER COLLE.	1	1			
	Q242020000	ARANDELA ABANICO A4 A.304	FAN SHAPED WASHER A.4	3	3			
	Q032021000	TORNILLO ALOMADO M4x10	CURVED SCREW M.4x10	3	3			
14	T722803000	GUIA CARRO COMP. IZDA. 20/11	COMPLE. LEFT TROLLEY GUIDE	_	1			
S/Nº	T722802000	GUIA CARRO COMP. DCHA. 20/11	COMPL. RIGHT TROLLEY GUIDE	_	1			
15	T742801000	BASE EXTERIOR 20/11	EXTERIOR BASE 20/11	1	1			
S/Nº	T712803000	REFUERZO BASE 20/11	REINFORCEMENT BASE	1	1			
	Q412002000	REMACHE AVINOX Ø4X10	AVINOX RIVET Ø4X10	12	12			
16	T650702000	TAPA CUBRE SISTEMA LAVADO	COVER WASHING SYSTEM BOX	_	1			
16	T330752500	TAPA SISTEMA LAVADO	TOP WASHING SYSTEM	_	1			
	Q152004000	TORNILLO APLAST. M5X13 A 304	FLAT SCREW M.5x13	_	9			
17	T650701500	CAJA CUBRE SISTEMA LAVADO	CLEANING SYSTEM BOX	_	1			
17	T330753000	CAJA CUBRE BOMBA LAVADO	CLEANING PUMP BOX	_	1			
	Q221342000	REMACHE EXAGONAL M.5	HEXAGONAL RIVET M.5	_	9			
S/Nº	T550702000	GUIA1 CAJA CUBRE SIST LAVADO	GUIDE1 WASHING SYSTEM BOX	_	1			
S/Nº	T550701000	GUIA2 CAJA CUBRE SIST LAVADO	GUIDE2 WASHING SYSTEM BOX	_	1			
	Q412002000	REMACHE AVINOX Ø4X10	AVINOX RIVET Ø4X10	_	15			
18	X260151000	PATA REGULABLE	REGULABLE LEG	4	4			
	Q232040000	ARANDELA A6	WASHER A.6	16	16			
	Q242040000	ARANDELA ABANICO A6 A.304	FAN SHAPED WASHER A.6	16	16			
	Q012043000	TORNILLO EXAGONAL M6x20	HEXAGONAL BOLT M6x20	16	16			
19	T702805000	PANEL IZQUIERDO 20/11	LEFT PANEL 10/21	1	1			
	Q302022000	ARANDELA 16X6X1.2 A.304	FLAT WASHER 16x6x1,2	7	7			
	Q012042000	TORNILLO EXAGONAL M6x15	HEXAGONAL BOLT M6x15	7	7			
20	T452809000	DUCHA	SHOWER	1	1			
S/Nº	T452834000	MANGO DUCHA	SHOWER HANDLE	_	1			
S/Nº	T542821000	SOPORTE DUCHA	SHOWER SUPPORT	_	1			
21	T742808000	PANEL CANTONERA	PROTECTOR PANEL	1	1			

Зип Общепит

vsezip.ru

+7(812)987-08-81

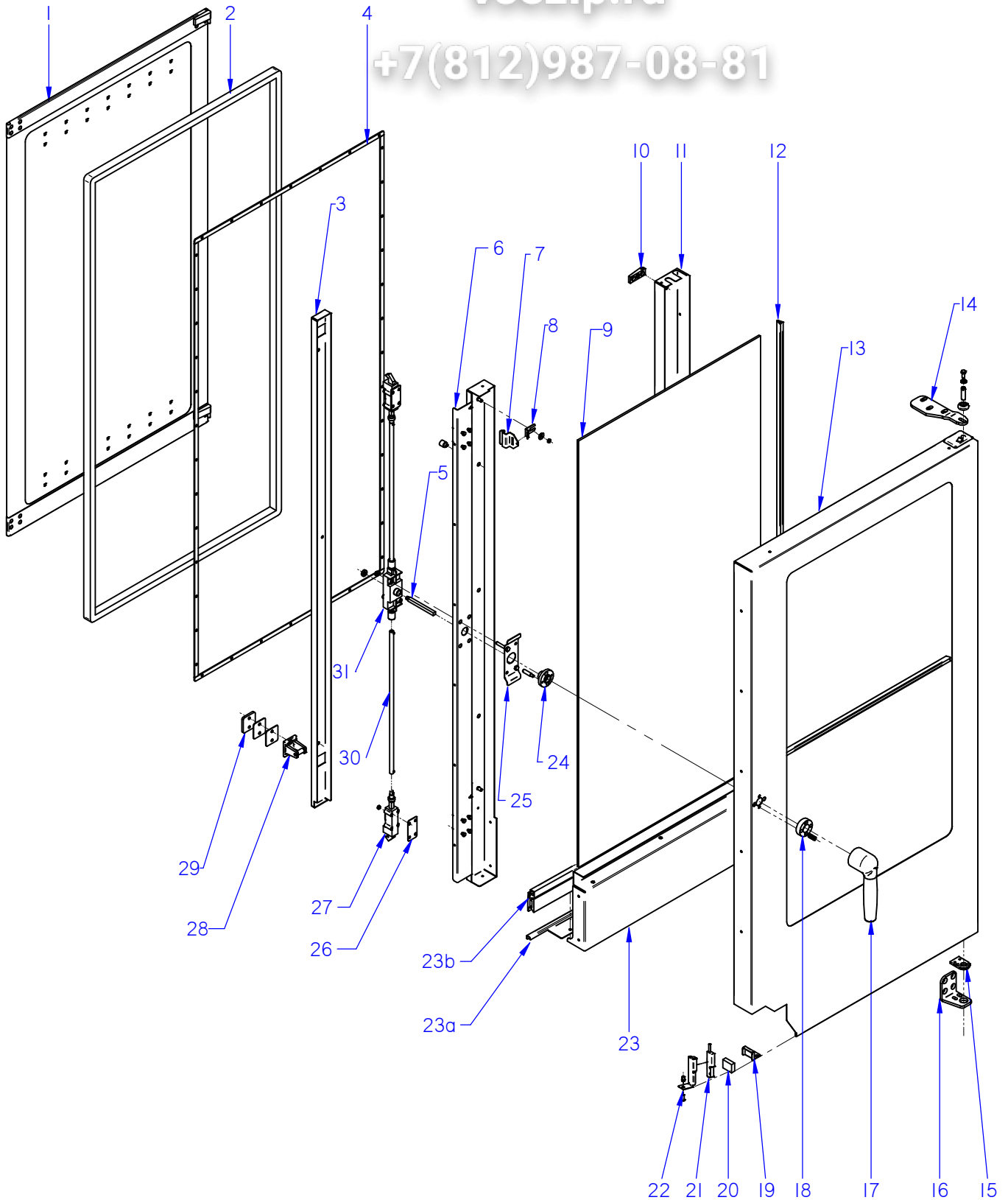

ITEM MARCADO EN COLOR = REPUESTO RECOMENDADO  
COLOURED ITEM = RECOMMENDED SPARE PART

N plano	Firma	Fecha	Aparato	PUERTA / DOOR	Lamina	Fagor Industrial S.Coop. <b>FAGOR</b>
C-2752	<i>(Signature)</i>	2010-12	HORNOS COG / VG / VPG-201		3	Oñate



MOD.	HORNOS / OVEN	ZONA / ZONE	PUERTA / DOOR					
ITEM	CODIGO	DENOMINACION	TEXTO	COG-201	VG-201	VPG-201		
	1100003148	KIT PUERTA 20/11 COMPL.	DOOR 20/11 KIT	1	1	1		
1	1100003125	KIT CRISTAL INTER. 20/11	20/11 INNER GLASS KIT	1	1	1		
2	R090510000	JUNTA DE PUERTA 20-11	DOOR JOINT	1	1	1		
3	T720508000	TAPA CIERRE PUERTA 20/11	DOOR CLOSING COVER 20/11	1	1	1		
	Q032021000	TORNILLO ALOMADO M4X10	CURVED SCREW M.4x10	2	2	2		
4	R090512000	FIJACION JUNTA COMP 20-11	FASTENING SEAL	1	1	1		
5	T490519000	EJE DE MANILLA PUERTA	LEVER SHAFT	1	1	1		
	T130505000	CASQUILLO	BUSHING	1	1	1		
6	T720505000	CONTRAP MANILLA COMPL 20/11	COMPLETE HANDLE DOOR 20/11	1	1	1		
	Q412002000	REMACHE AVINOX Ø4X10	AVINOX RIVET Ø4X10	12	12	12		
	T300513000	TOPE CRISTAL INTERIOR10/21	INTERIOR GLASS BUFFER 10/2	3	3	3		
	T300537000	TOPE CRISTAL INTERIOR	INTERIOR GLASS BUFFER	3	3	3		
7	T300514000	PESTILLO	LATCH	2	2	2		
	R660605000	MUELLE TENSOR	LATCH TENSOR SPRING	2	2	2		
	Q302022000	ARANDELA 16X6X1.2 A.304	FLAT WASHER 16x6x1,2	2	2	2		
	Q242030000	ARANDELA ABANICO A5 A.304	FAN SHAPED WASHER A.5	2	2	2		
	Q162030000	TUERCA EXAGONAL M5	HEXAGONAL NUT M.5	2	2	2		
8	R090558000	BASE DE PESTILLO	LATCH BASE	2	2	2		
9	R090562000	CRISTAL EXTERIOR 20/11	EXTERNAL GLASS 20/11	1	1	1		
10	R670615000	BASE DE BISAGRA	HINGE BASE	2	2	2		
	Q042032000	TORNILLO AVELLANADO M5X15	COUNTERSUNK SCREW M.5x15	2	2	2		
11	T720503000	CONTRAPUERTA BISAGRA 20/11	INNER DOOR HINGE 20/11	1	1	1		
	Q412002000	REMACHE AVINOX Ø4X10	AVINOX RIVET Ø4X10	12	12	12		
12	3715200000	JUNTA CRISTAL	WINDOW SEAL	3	3	3		
13	T720501000	PUERTA 20/11	DOOR 20/11	1	1	1		
14	T300520500	BISAGRA SUPERIOR 10/21	UPPER HINGE 10/21	1	1	1		
14	T300520000	BISAGRA SUPERIOR 21	UPPER HINGE 21	1	1	1		
	Q302025000	ARANDELA 8,4X20X1.5	WASHER 8,4X20X1.5	3	3	3		
	Q261050000	ARANDELA MUELLE A8	SPRING WASHER A8	3	3	3		
	Q012055000	TORNILLO EXAGONAL M8X30	HEXAGONAL BOLT M8X30	3	3	3		

MOD.		HORNOS / OVEN		ZONA / ZONE		PUERTA / DOOR		
ITEM	CODIGO	DENOMINACION	TEXTO	COG-201	VG-201	VPG-201		
S/Nº	R660534000	EJE SUPERIOR	UPPER SHAFT	1	1	1		
	R662807000	ARANDELA AMARRE	DOOR ANCHORING WASHER	1	1	1		
	Z850519000	RESORTE 06329	SPRING 06329	1	1	1		
15	R660549000	GUIA EJE INFERIOR FUNDIDO	LOWER SHAFT GUIDE	1	1	1		
	Q062040000	TORNILLO AVELLANADO M6X16	COUNTERSUNK SCREW M.6x16	4	4	4		
16	T700501500	BISAGRA INFERIOR PLEGADA	LOWER FOLDER HINGE	1	1	1		
17	T130502000	MANILLA COMPLETA	HANDLE	1	1	1		
	Q032032000	TORNILLO ALOMADO M5X15	CURVED SCREW M5X15	2	2	2		
	Q271033000	ARANDELA DE SEGURIDAD Ø6	SAFETY WASHER Ø 6	1	1	1		
	Q132042000	VARILLA ROSCADA M6X15	THREADED ROD M.6x15	1	1	1		
	T130510000	TAPON Ø 16 BAGAL Ext.	COVER Ø 16 BAGAL Ext.	1	1	1		
18	T130514000	SOPORTE RESORTE	SPRING HOLDER	1	1	1		
	T130506000	RESORTE 34548	SPRING	2	2	2		
	Q032032000	TORNILLO ALOMADO M5x15	CURVED SCREW M.5x15	2	2	2		
19	T300525000	SOPORTE IMAN	MAGNET HOLDER	1	1	1		
	Q222011000	REMACHE EXAGONAL M.5	HEXAGONAL RIVET M.5	1	1	1		
	Q032031000	TORNILLO ALOMADO M5X10	CURVED SCREW M5X10	1	1	1		
20	T300526000	IMAN	MAGNET	1	1	1		
21	Z100522000	INTERRUPTOR MAGNETICO	MAGNETIC SWITCH (DOOR)	1	1	1		
22	T302819000	SOPORTE MICRO PUERTA	DOOR MAGNETIC SWITCH HOLD	1	1	1		
	Q221342000	REMACHE EXAGONAL M.5	HEXAGONAL RIVET M.5	3	3	3		
23	T720507000	CHAPA AMARRE CONTRAP 20/11	DOOR REVERSE FASTE. PLATE	1	1	1		
S/Nº	R090553000	CHAPA JUNTA CONTRAPUERTA	DOOR REVERSE SEAL PLATE	1	1	1		
23a	R090571000	SUPERIOR CIERRE PUERTA 20/11	UPPER DOOR LOCK	1	1	1		
23b	R090551000	JUNTA CIERRE INFERIOR 20/11	LOWER DOOR LOCK	1	1	1		
24	T130515000	GUIA MANILLA	HANDLE GUIDE	1	1	1		
	T490518000	PITON ENGANCHE PUERTA	DOOR FASTENER SPIKE	2	2	2		
25	T130511000	SUPLEMENTO SUJ. CERRADURA	LOCK FIXING SUPPLEMENT	1	1	1		
26	T080503000	SUPLEMENTO ELEMENTO CIERRE	CLOSING ELEMENT SUPPLEMEN	6	6	6		
27	T080504000	ELEMENTO CIERRE	CLOSING COMPONENT	2	2	2		



Зип Общепит

vsezip.ru

+7(812)987-08-81

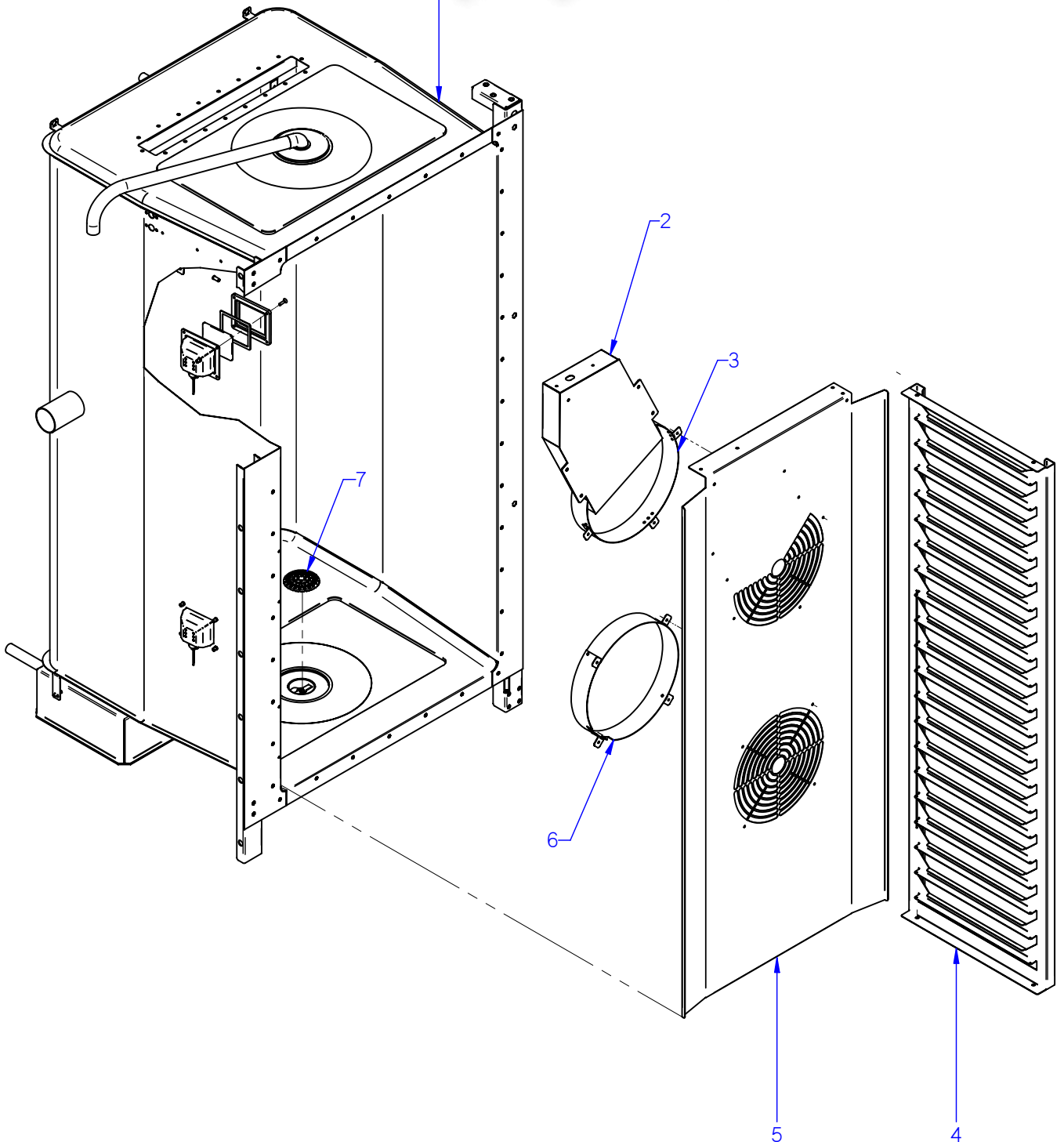

ITEM MARCADO EN COLOR = REPUESTO RECOMENDADO  
COLOURED ITEM = RECOMMENDED SPARE PART

N plano	Firma	Fecha	Aparato	MUEBLE INTERIOR	Lamina	Fagor Industrial S.Coop. <b>FAGOR</b>
C-2753	<i>(Signature)</i>	2010-12	HORNOS COG / VG / VPG-201		4	Oñate

MOD.		HORNOS / OVEN	ZONA / ZONE	MUEBLE INTERIOR / INTERIOR OVEN				
ITEM	CODIGO	DENOMINACION	TEXTO	COG-201	VG-201	VPG-201		
1	T732601000	CUERPO INTERIOR HGC-20/21	INTERIOR BODY HGC -20/21	1	-	-		
1	T742601000	CUERPO INTERIOR HGV-20/11	INTERIOR BODY HGV -20/11	-	1	-		
1	T752601000	CUERPO INTERIOR HGP-20/21	INTERIOR BODY HGP -20/21	-	-	1		
S/Nº	T360712000	PUNTA DIFUSORA LAVADO	WASHING DISPENSER POINT	-	-	1		
2	T142639000	CONDUCTO DE HUMOS 2021	SMOKE DUCT 2021	1	1	1		
3	T132645000	SUPLEMEN. CUBREVEN. ABIERTO	FAN COVER SUPPLEMEN. OPE	1	1	1		
4	R092695000	PORTABANDEJAS 20/11	TRAY HOLDER 20/11	2	-	-		
S/Nº	R672692000	TOPE DE PORTABANDEJAS 10/11	TRAY HOLDER BUFFER 10/11	4	-	-		
5	T102614000	CUBREVENTILADOR 20/11G	FAN COVER 20/11G	1	1	1		
6	T132644000	SUPLEMEN. CUBREVENTILADOR	FAN COVER SUPPLEMENT.	1	1	1		
S/Nº	T302643000	FIJACIÓN SUPLEMENTO	FAN COVER SUPPLEM. BINDING	9	9	9		
	Q412002000	REMACHE AVINOX Ø4x10	RIVET AVINOX Ø4x10	35	35	35		
7	T642657000	FILTRO DESAGÜE	DRAINAGE FILTER	1	1	1		
8	T303023000	PORTALAMPARAS	LAMP HOLDER	2	2	2		
S/Nº	T303026000	JUNTA EXTERIOR LAMPARA	LAMP OUTER JOINT	2	2	2		
S/Nº	T303025000	CRISTAL LAMPARA	LAMP GLASS	2	2	2		
S/Nº	T303027000	JUNTA INTERIOR LAMPARA	LAMP INNER JOINT	2	2	2		
S/Nº	T303047000	MARCO LAMPARA	LAMP ANCHORING PLATEN	2	2	2		
S/Nº	R663013000	LAMPARA 10W-12V	LIGHT 10W 12V	2	2	2		
	Q222041000	REMACHE EXAGONAL M.4 INOX	HEXAGONAL RIVET M.4	8	8	8		
	Q032021000	TORNILLO ALOMADO M4X10	CURVED SCREW M.4x10	8	8	8		
S/Nº	R672665000	PARRILLA 1X1 REF. 2025201	2X1 REF. 2025200 GRILLE	1	1	1		
S/Nº	R252816000	BANDEJA 1X1	1X1TRAY	1	1	1		

Зип Общепит

vsezip.ru

+7(812)987-08-81

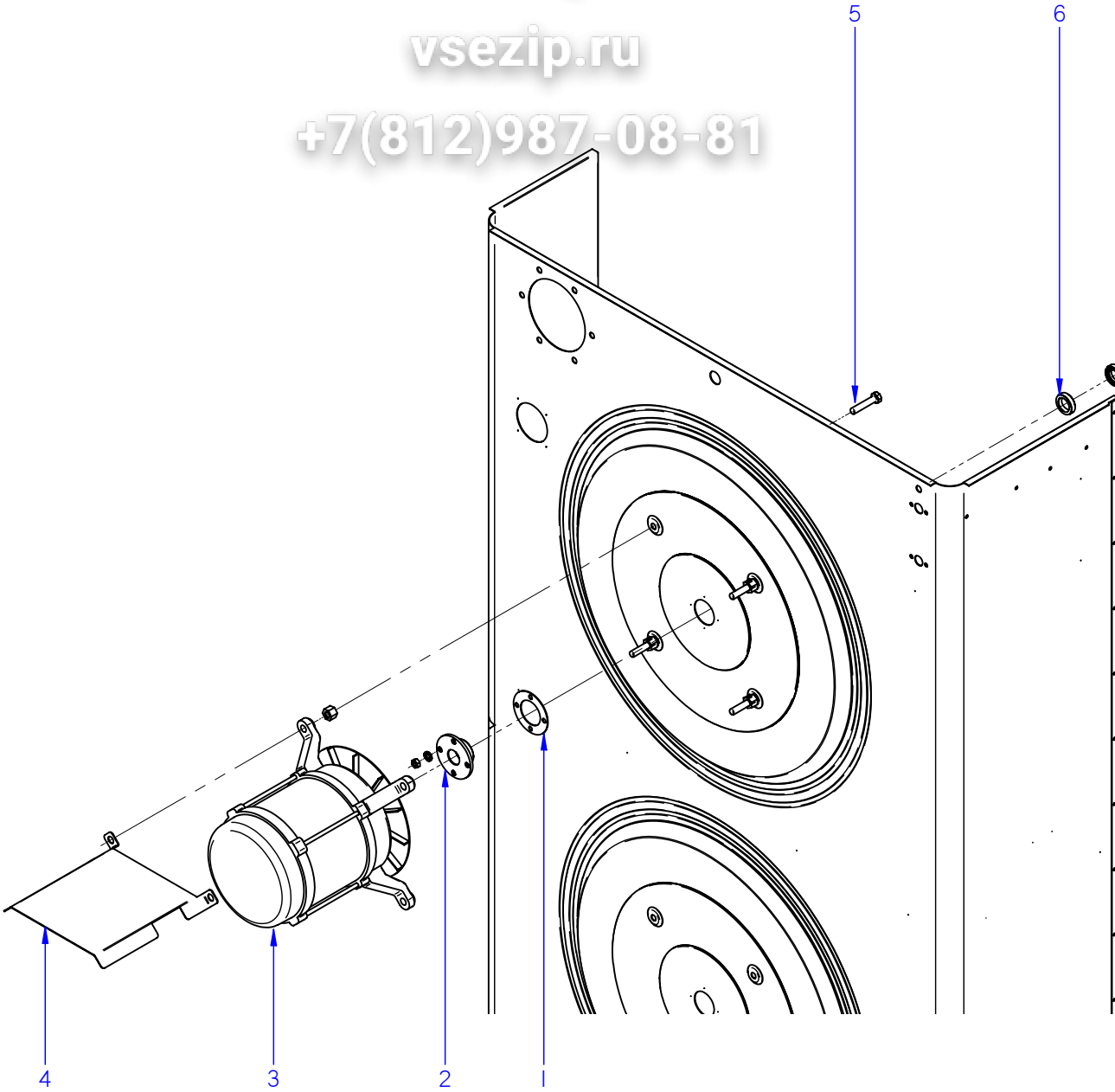

ITEM MARCADO EN COLOR = REPUESTO RECOMENDADO  
COLOURED ITEM = RECOMMENDED SPARE PART

N plano	Firma	Fecha	Aparato	Lamina	Fagor Industrial S. Coop. <b>FAGOR</b> Orte
C-2754	<i>(Firma)</i>	2010-12	HORNOS COG / VG / VPG-201	5	
			TURBINA / TURBINE		

MOD.	HORNOS / OVEN		ZONA / ZONE	TURBINA / TURBINE			
ITEM	CODIGO	DENOMINACION	TEXTO	COG-201	VG-201	VPG-201	
1	R662685000	JUNTA CASQUILLO RETEN	SEAL BUSHING GASKET	2	2	2	
	Q232030000	ARANDELA A5	WASHER A5	8	8	8	
	Q242030000	ARANDELA ABANICO A5	FAN SHAPED WASHER A.5	8	8	8	
	Q012031000	TORNILLO EXAGONAL M5x10 A304	HEXAGONAL SCREW M.5x10	8	8	8	
2	R662684000	CASQUILLO RETEN	SEAL BUSHING	2	2	2	
3	T323040000	MOTOR DOBLE GIRO 1VEL. 750W.	DOUBLE ROTATION MOTOR 1VE	2	2	2	
	R663057000	CASQUILLO AMARRE MOTOR	MOTOR FASTENING BUSHING	8	8	8	
	Q242040000	ARANDELA ABANICO A6	FAN SHAPED WASHER A.6	8	8	8	
	Q152039000	TORNILLO EXAGONAL M6X35	HEXAGONAL SCREW M.6X35	8	8	8	
4	T142635000	TEJADILLO MOTOR	MOTOR ROOF	2	2	2	
5	Q012056000	TORNILLO EXAGONAL M8X40	HEXAGONAL SCREW M8X40	8	8	8	
6	R662627000	RETEN 17X28X7V	RETAINER 28x17x7	4	4	4	
7	Q302023000	ANILLO DE SEGURIDAD Ø 28X1.2	SAFETY RING 28x1,2	2	2	2	
8	R703050000	TURBINA RECTA Ø350X127 HANN.	TURBINE RECTA Ø350X127 HA.	2	2	2	
	R763010000	ARANDELA SEGURIDAD HANNING	HANNING SAFETY WASHER	2	2	2	
	Q012063000	TORNIL. EXAGONAL M10X20 A.304	HEXAGONAL SCREW M.10x20	2	2	2	

Вип Общепит  
 vsezip.ru  
 +7(812)987-08-81

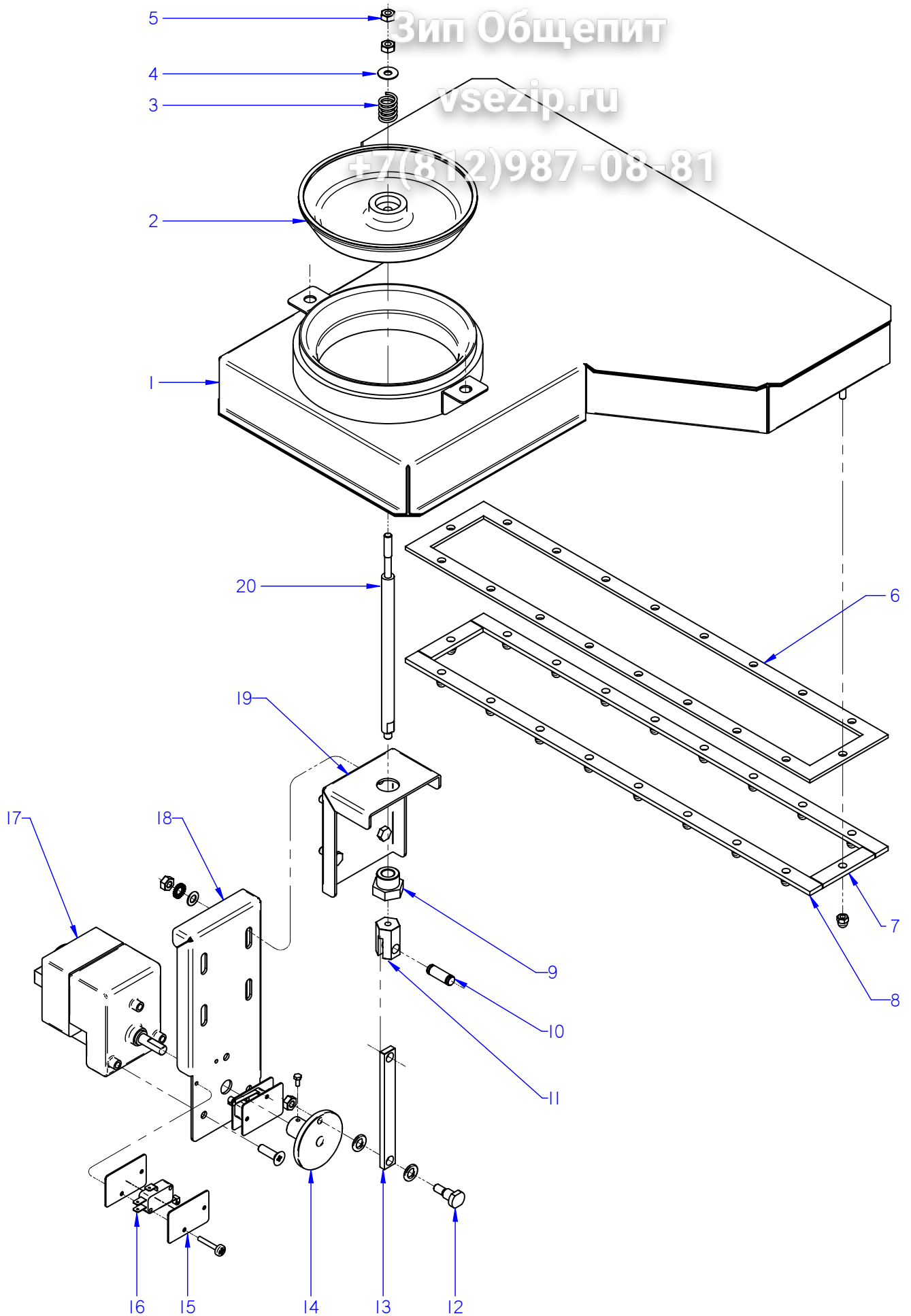

ITEM MARCADO EN COLOR = REPUESTO RECOMENDADO  
 COLOURED ITEM = RECOMMENDED SPARE PART

N plano	Firma	Fecha	Aparato	CHIMENEA / CHIMNEY	Lamina	Fagor Industrial S.Coop. <b>FAGOR</b>
C-2755	<i>(Signature)</i>	2010-12	HORNOS VG-201 / VPG-201		6	Oñate



MOD.		HORNOS / OVEN	ZONA / ZONE	CHIMENEA / CHIMNEY			
ITEM	CODIGO CODE	DENOMINACION	NAME	VG-201	VPG-201		
1	T745001000	CHIMENEA COM. HGV-20/11	COMPLET. CHIMNEY HGV-20/11	1	1		
1	T755001000	CHIMENEA COM. HGP 20/11	COMPLET. CHIMNEY HGP 20/11	1	1		
2	T125027000	RETENCION DE VAPORES	CLOSE CHIMNEY	1	1		
3	R725008000	RESORTE	SPRING	1	1		
4	Q302022000	ARANDELA 16X6X1.2 A.304	FLAT WASHER 16x6x1,2	2	2		
5	Q162040000	TUERCA EXAGONAL M6	HEXAGONAL NUT M.6	2	2		
6	T132631000	JUNTA CHIMENEA	FLUEPIPE SEAL	1	1		
7	T132634000	PLETINA REF CORTO INFERIOR	BOTTOM DECK	2	2		
	Q213131000	TUERCA SOMBRERETE M5	SOMBRERETE NUT M5	18	18		
8	T132632000	PLETINA REF LARGO INFERIOR	LONG BOTTOM DECK	2	2		
9	R725030000	TUERCA GUIA RETENCION	RETAINER NUT GUIDE	1	1		
	Q307067000	JUNTA TORICA 9.19x2.62	O-RING 9.19x2.62	1	1		
10	T135046000	EJE DE GUIA DE RETENCION	GUIDE SHAFT HOLDING	1	1		
	Q271033000	ARANDELA DE SEGURIDAD 6	SAFETY WASHER 6	2	2		
11	T135045000	SUPLEMEN. EJE DE RETENCION	AXIS CHARGE RETENTION	1	1		
12	T135009000	EJE DE LEVA	CAM SHAFT	1	1		
	Q308013000	ARANDELA Ø14xØ8x2	FLAT WASHER Ø14xØ8x2	2	2		
	Q162040000	TUERCA EXAGONAL M6	HEXAGONAL NUT M.6	1	1		
13	T845012000	PALANCA DE ELEVACION	LIFT LEVER	1	1		
14	T135012000	LEVA	CAM	1	1		
	Q151320000	TORNILLO ALOMADO M4X6 ZINC.	CURVED SCREW M4X6 ZINC.	2	2		
15	R010535000	PLACA SEPARADORA	SPACER PLATE	4	4		
	Q032013000	TORNILLO ALOMADO M3X20	CURVED SCREW M3X20	4	4		
	Q221350000	TUERCA AUTOBLOCANTE M3	SELF-LOCKING NUT M3	4	4		
16	R010534000	INTERRUPTOR PUERTA	DOOR SWITCH	2	2		
17	T113010000	MOTOR CHIMENEA	FLUEPIPE MOTOR	1	1		
17	T843011000	MOTOR CHIMENEA A GAS	FLUEPIPE MOTOR	1	1		
	Q042031000	TORNILLO AVELLANADO M5x10	COUNTERSUNK SCREW M.5x15	3	3		

# Зип Общепит

vsezip.ru

+7(812)987-08-81

MOD.		HORNOS / OVEN	ZONA / ZONE	CHIMENEA / CHIMNEY					
ITEM	CODIGO CODE	DENOMINACION	NAME	VG-201	VPG-201				
18	T845011000	ESCUADRA AMARRE MOTOR	MOTOR FASTENING BRACKET	1	1				
	Q232040000	ARANDELA A6	FLAT WASHER A.6	4	4				
	Q242040000	ARANDELA ABANICO A6 A.304	FAN SHAPED WASHER A.6	4	4				
	Q162040000	TUERCA EXAGONAL M6	HEXAGONAL NUT M.6	4	4				
19	T845025000	SOPORTE AMARRE MOTOR	TIE BRACKET MOTOR	1	1				
20	T135044000	EJE DE RETENCION DE VAPORES	VAPOR CHECK SHAFT	1	1				

Зип Общепит

vsezip.ru

+7(812)987-08-81

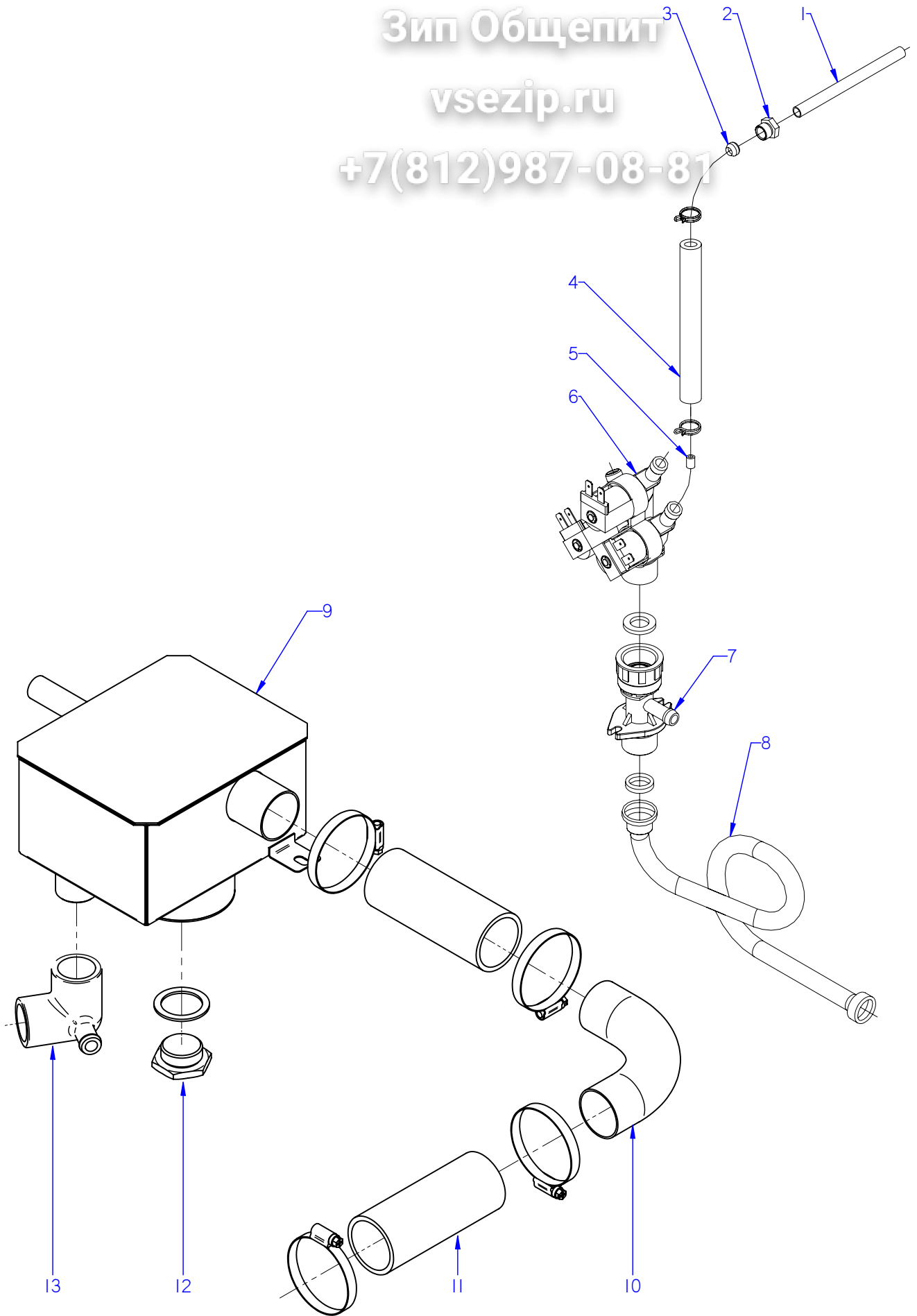

ITEM MARCADO EN COLOR = REPUESTO RECOMENDADO  
COLOURED ITEM = RECOMMENDED SPARE PART

N plano	Firma	Fecha	Aparato	CONDUCCIONES DE AGUA / WATER PIPES	Lamina	Fagor Industrial S.Coop. <b>FAGOR</b>
C-2756	<i>(Signature)</i>	2010-12	HORNOS COG-201 / VG-201		7	Oñate

MOD.	HORNOS / OVEN	ZONA / ZONE	CONDUCCIONES DE AGUA / WATER PIPES					
ITEM	CODIGO CODE	DENOMINACION	NAME	COG-201	VG-201			
S/Nº	1100003163	KIT VALVULA DE LAVADO COMP.	WASHING VALVE KIT	-	1			
1	R695033000	TUBO INYECTOR 6/11	INJECTOR PIPE 6/11	1	1			
2	R695003000	MANGUITO CIERRE	CLOSING SLEEVE	1	1			
3	R695004000	BICONO	BICONE	1	1			
4	3676900000	TUBO GOMA NEGRA Ø17*10	BLACK RUBBER PIPE Ø17*10	1	1			
	Q901310000	ABRAZADERA ELASTICA 16.8-17.7	ELASTIC CLAMP 16.8-17.7	2	2			
5	R715011000	REGULADOR 0,5L NARANJA	0.5 L ORANGE REGULATOR	1	-			
5	R665041000	REGULADOR 0,25L ROJO	0.25 L RED REGULATOR	-	1			
6	Z701135000	E.V.SIMP.220V COD.255.208	E.V.SIMP.220V COD.255.208	1	-			
6	Z611123000	ELECTR. TRIPLE COD.255.641	TRIPLE SOLENOID VALVE 255.6	-	1			
7	T645006000	ENTRADA DE AGUA COMPLETA	COMPLETE WATER INLET	-	1			
	Q307031000	JUNTA TUBO 14X24X3	JOINT 14X24X3	-	2			
	Q012021000	TORNILLO EXAGONAL M4x10 A304	HEXAGONAL BOLT M4x10 A304	-	2			
	Q162020000	TUERCA EXAGONAL M4	HEXAGONAL NUT M.4º	-	2			
8	Z601114000	MANGUERA ENTRADA AGUA	WATER INTAKE HOSE	1	1			
9	T835001000	CAJA DESAGÜE COMPL. HGC	COMPL. DRAINAGE BOX G HGC	1	-			
9	T845001000	CAJA DESAGÜE COMPL. HGV	COMPL. DRAINAGE BOX G HGV	-	1			
	Q232040000	ARANDELA A6	WASHER A6	1	1			
	Q242040000	ARANDELA ABANICO A6	FAN WASHER A6	1	1			
	Q012042000	TORNILLO EXAGONAL M6X15 A304	HEXAGONAL BOLT M6X15 A304	1	1			
10	T815001000	CONDUCCIÓN DESAGÜE 6-10/11 E	DRAIN DRIVING 6-10/11 E	1	1			
11	3715800000	TUBO SILICONA ALTA Tª Ø43*57	HIGH SILICON PIPE Tª Ø43*57	2	2			
	Q901312000	ABRAZADERA ELASTI. Ø50,6-53,2	ELAST. CLAMP Ø50,6-53,2	4	4			
12	T305052000	TAPÓN DESAGÜE	DRAINING PLUG	1	1			
	T305053000	JUNTA DESAGÜE	DRAINAGE BOARD	1	1			
13	R665080000	CODO DESAGUE	DRAIN ELBOW	1	1			

Зип Общепит

vsezip.ru

+7(812)987-08-81

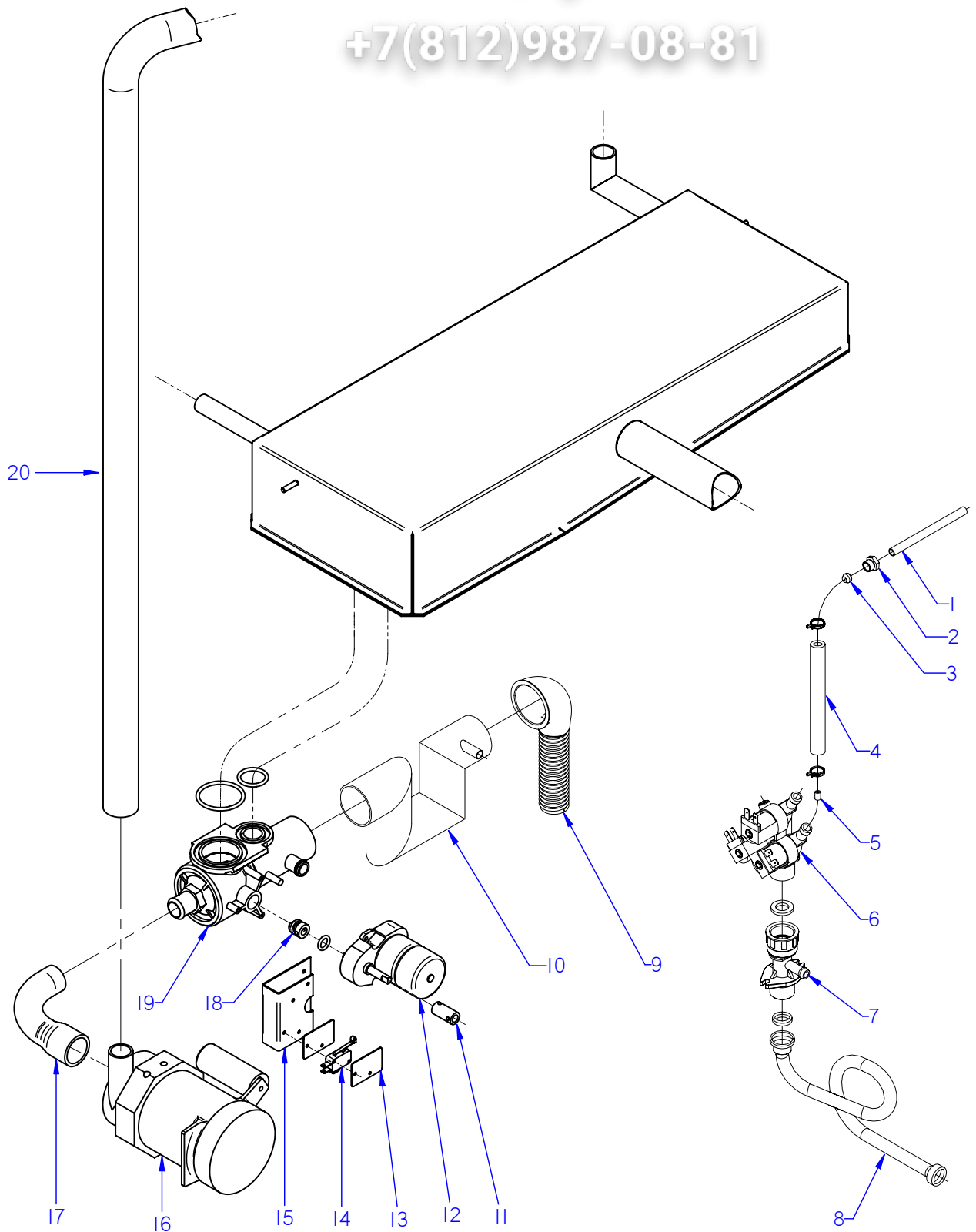

ITEM MARCADO EN COLOR = REPUESTO RECOMENDADO  
COLOURED ITEM = RECOMMENDED SPARE PART

N plano	Firma	Fecha	Aparato	CONDUCCIONES DE AGUA / WATER PIPES	Lamina	Fagor Industrial S.Coop. <b>FAGOR</b>
C-2757	<i>name (signature)</i>	2010-12	HORNOS VPG-201		8	Oñate

MOD.	HORNOS / OVEN	ZONA / ZONE	CONDUCCIONES DE AGUA / WATER PIPE				
ITEM	CODIGO CODE	DENOMINACION	NAME	VPG-201			
1	R695033000	TUBO INYECTOR 6/11	INJECTOR PIPE 6/11	1			
2	R695003000	MANGUITO CIERRE	CLOSING SLEEVE	1			
3	R695004000	BICONO	BICONE	1			
4	3676900000	TUBO GOMA NEGRA Ø17*10	BLACK RUBBER PIPE Ø17*10	1			
	Q901310000	ABRAZADERA ELASTICA 16.8-17.7	ELASTIC CLAMP 16.8-17.7	1			
5	R665041000	REGULADOR 0,25L ROJO	0.25 L RED REGULATOR	1			
6	Z611123000	ELECTR. TRIPLE COD.255.641	TRIPLE SOLENOID VALVE 255.6	1			
7	T645006000	ENTRADA DE AGUA COMPLETA	COMPLETE WATER INLET	1			
	Q307031000	JUNTA TUBO 14X24X3	JOINT 14X24X3	2			
8	Z601114000	MANGUERA ENTRADA AGUA	WATER INTAKE HOSE	1			
9	Z200910000	MANGUERA DESAGUE	DRAINAGE HOSE	1			
10	T360718000	SIFON SALIDA VALVULA	VALVE OUTPUT SIPHON	1			
	Q881307000	ABRAZADERA 40-60	CLAMP 40-60	1			
11	T330733000	CASQUILLO MOTOR MICRO	MICRO MOTOR BUSHING	1			
	Q151320000	TORNILLO ALOMADO M4X6 H.ZIN.	CURVED SCREW M4X6 H.ZIN.	2			
	Q371026000	MANGUITO SUJEC. 4X14 DIN1481	HOSE FASTENING 4X14 DIN1481	1			
	Q052032000	TORNILLO ALLEN M.5x15(+)	ALLEN HEAD SCREW M.5x15(+)	2			
12	T330711000	MOTOR VALVULA	VALVE MOTOR	1			
	Q042022000	TORNILLO AVELLANADO M4X15	COUNTERSUNK SCREW M.4x15	2			
13	R010535000	PLACA SEPARADORA	SPACER PLATE	4			
	Q032013000	TORNILLO ALOMADO M3X20	CURVED SCREW M3X20	4			
	Q221350000	TUERCA AUTOBLOCANTE M3	SELF-LOCKING NUT M3	4			
14	R010534000	INTERRUPTOR PUERTA	DOOR SWITCH	2			
15	T330713000	CHAPA SUJECCION MICROS	FASTENING PLATE MICROS	1			
15	T330754000	SOPORTE MICROS LAVADO	MICROS WASH STAND	1			
16	T360715000	MOTOBOMBA 5213E2450 FIR 50Hz	MOTOR-PU. 5213E2450 FIR 50Hz	1			
16	T360722000	MOTOBOMBA 5213E246X FIR 60Hz	MOTOR-PU. 5213E246X FIR 60Hz	1			
17	T330731000	GOMA VALVULA BOMBA	PUMP VALVE RUBBER	1			
	Q881304000	ABRAZADERA 20-32	CLAMP 20-32	1			
	Q881305000	ABRAZADERA 25-40	CLAMP 25-40	1			

MOD.	HORNO / OVEN	ZONA / ZONE	CONDUCCIONES DE AGUA / WATER PIPE					
		<b>+7(812)987-08-81</b>						
ITEM	CODIGO CODE	DENOMINACION	NAME	VPG-201				
18	T330707000	PUNTA ACOPLE MOTOR A VALV.	CONN. POINT MOTOR TO VAL.	1				
S/Nº	Q307084000	JUNTA TORICA Ø11X3.5	O-RING Ø18X3.5	1				
S/Nº	12019645	JUNTA TORICA Ø10x3.5	O-RING Ø10X3.5	1				
19	T330723000	CUERPO VALVULA COMPLETO	COMPLETE VALVE BODY	1				
	T330703000	JUNTA TEFLON VALVULA	TEFLON VALVE BOARD	2				
	T330703000	JUNTA TEFLON VALVULA	TEFLON VALVE BOARD	1				
	T330749000	JUNTA TEFLON VALVULA	TEFLON VALVE BOARD	1				
	Q307080000	JUNTA TORICA Ø52X3,5	O-RING Ø52X3.5	1				
	Q307079000	JUNTA TORICA Ø33x3,5	O-RING Ø33x3.5	1				
S/Nº	Z200910000	MANGUERA DESAGUE	DRAIN HOSE	1				
20	3716000000	TUBO SILICONA Tº Ø 35*27	HIGH SILICON PIPE Tº Ø 35*27	1				
	Q881305000	ABRAZADERA 25-40	CLAMP 25-40	2				

Зип Общепит

vsezip.ru

+7(812)987-08 81

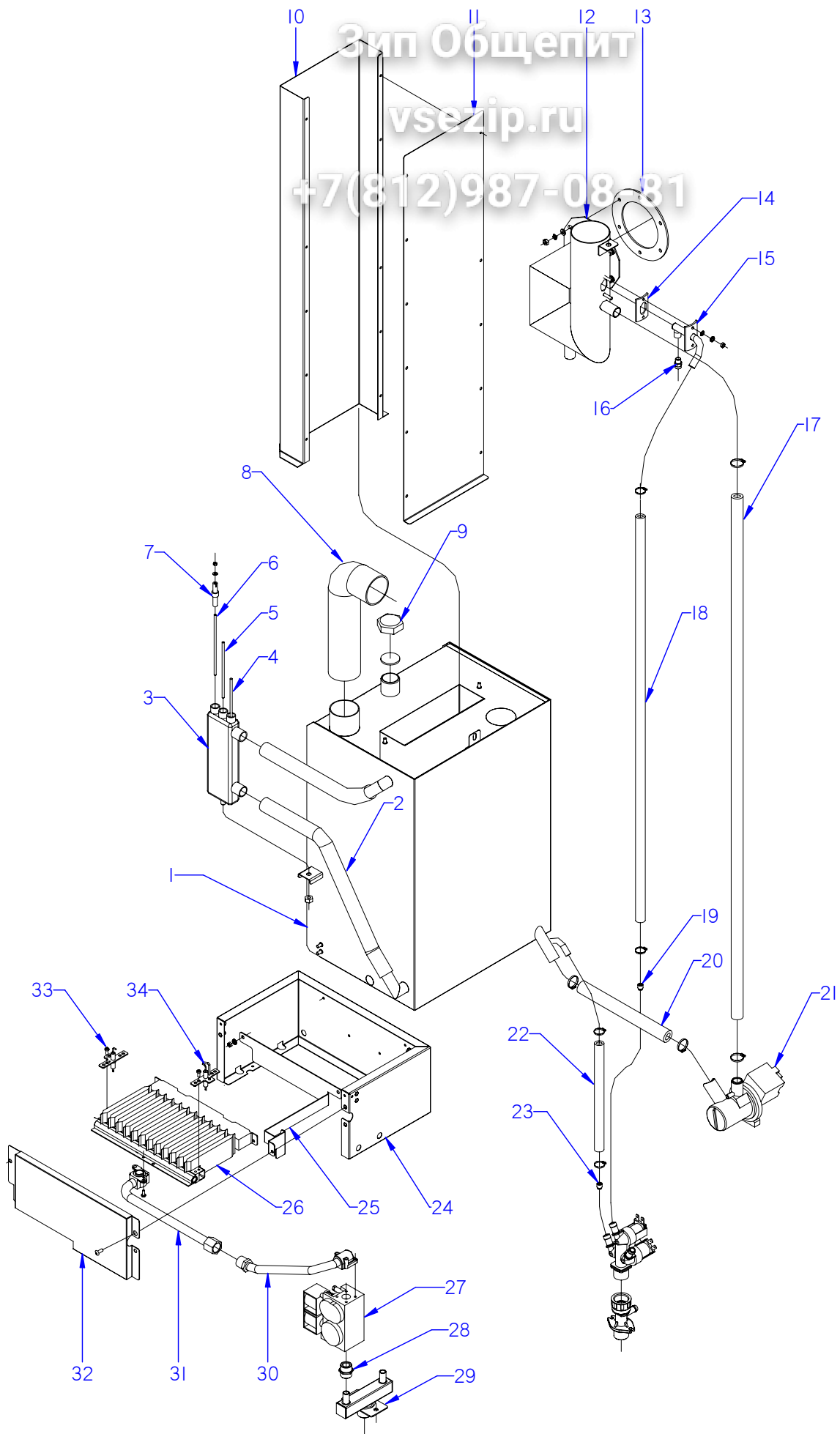

ITEM MARCADO EN COLOR = REPUESTO RECOMENDADO  
COLOURED ITEM = RECOMMENDED SPARE PART

N plano	Firma	Fecha	Aparato	CIRCUITO DE VAPOR / STEAM CIRCUIT	Lamina	Fagor Industrial S.Coop. <b>FAGOR</b>
C-2758	<i>[Signature]</i>	2010-12	HORNO VG-201 / VPG-201		9	Oñate



MOD.	HORNOS / OVEN	ZONA / ZONE	CIRCUITO DE VAPOR / STEAM CIRCUIT				
		+7(812)987-08-81					
ITEM	CODIGO CODE	DENOMINACION	NAME	VG-201	VPG-201		
1		<b>KIT GENERADOR DE VAPOR 201</b>	<b>STEAM GENERATOR KIT 201</b>	1	1		
1	T845006000	GENERADOR VAPOR 6-10-20/11G	STEAM GENERATOR 6-10-20/11G	1	1		
S/Nº	Z956104000	INYECTOR 1.1 A-15009 GN	1.1 A-15 009 INJECTOR GN	12	12		
2	3715900000	TUBO SILICONA ALTA Tª Ø26*18	HIGH SILICON PIPE Tª Ø26*18	2	2		
	Q901312000	ABRAZADERA ELASTI. Ø50,6-53,2	ELAST. CLAMP Ø50,6-53,2	4	4		
3	T325079000	BOTE DE NIVELES	LEVELS VESSEL	1	1		
	Q228051000	TUERCA EXAGONAL M8 PLASTICO	HEXAGONAL NUT M8 PLASTIC	1	1		
4	R345063000	ELECTRODO DE NIVEL BAJO	LOW LEVEL ELECTRODE	1	1		
5	R345060000	ELECTRODO DE NIVEL ALTO	HIGH LEVEL ELECTRODE	1	1		
6	R345064000	ELECTRODO DE MASA	EARTH ELECTRODE	1	1		
7	R345069000	GUIA AISLANTE	INSULATION GUIDE	3	3		
8	T722608000	TUBO FLEXIBLE Ø53X360	FLEXIBLE TUBE Ø53X360	1	1		
8	12041855	TUBO FLEXIBLE Ø53x360 VARIL INO	FLEXIBLE TUBE ROD Ø53x360 IN	1	1		
	Q881307000	ABRAZADERA 40*60	CLAMP 40*60	2	2		
9	R015010000	TUERCA TAPON 1"	PLUG NUT 1"	1	1		
	R015011000	ARANDELA Ø32	WASHER Ø32	1	1		
10	T745005000	ANTER. CHIMENEA GENERADOR	FRONT FLUEPIPE GENERATOR	1	1		
11	T745006000	POSTER. CHIMENEA GENERADOR	REAR FLUEPIPE GENERATOR	1	1		
12	T745003000	RETORNO COMPLETO 2011	COMPLETE RETURN 2011	1	1		
	Q262040000	ARANDELA GROWER A6	WASHER GROWER A6	6	6		
	Q162040000	TUERCA EXAGONAL M6	HEXAGONAL NUT M6	6	6		
13	T145711000	JUNTA COLECT 20-11/20-21 GAS	COLLECTOR SEAL 20-11/20-21 G	1	1		
14	R725159000	JUNTA TUBO INYECTOR	INJECTOR PIPE SEAL	1	1		
15	T115112000	CONDUCCION DE VAHOS COMPL.	COMPL. VAPOUR DUCT	1	1		
16	T115086000	TOBERA 1/8"	NOZZLE 1/8	1	1		
	Q242030000	ARANDELA ABANICO A5 A.304	FAN WASHER A5 A.304	2	2		
	Q162030000	TUERCA EXAGONAL M5	HEXAGONAL NUT M5	2	2		
17	3715900000	TUBO SILICONA ALTA Tª Ø26*18	HIGH SILICON PIPE Tª Ø26*18	1	1		
	Q901311000	ABRAZADERA ELASTI. Ø26,7-28,1	ELAST. CLAMP Ø26.7-28.1	2	2		
18	3702500000	TUBO GOMA NEGRA Ø17xØ11	BLACK RUBBER PIPE Ø17*11	1	1		
	Q901310000	ABRAZADERA ELASTI. Ø16,8-17,7	ELAST. CLAMP Ø16.8-17.7	2	2		

<b>MOD.</b>	<b>HORNOS / OVEN</b>	<b>ZONA / ZONE</b>	<b>CIRCUITO DE VAPOR / STEAM CIRCUIT</b>
-------------	----------------------	--------------------	--

ITEM	CODIGO CODE	DENOMINACION	NAME	VG-201	VPG-201			
19	P443042000	REGULADOR 3L VERDE 254.023	REGULATOR 3L GREEN 254.023	1	1			
20	3715900000	TUBO SILICONA ALTA Tª Ø26*18	HIGH SILICON PIPE Tª Ø26*18	1	1			
	Q901311000	ABRAZADERA ELASTI. Ø26,7-28,1	ELAST. CLAMP Ø26.7-28.1	2	2			
21	Z220901000	BOMBA DESAGUE 30W	DRAINAGE PUMP 30W	1	1			
21	Z223501000	BOMBA DE DESAGUE 30W 60HZ	DRAINAGE PUMP 30W 60HZ	1	1			
22	3676900000	TUBO GOMA NEGRA Ø17xØ10	BLACK RUBBER PIPE Ø17*10	1	1			
	Q901310000	ABRAZADERA ELASTI. Ø16,8-17,7	ELAST. CLAMP Ø16.8-17.7	2	2			
23	Z601156000	REGULADOR 8L RO. 254.034	REGULATOR 8L RED 254.034	1	1			
24	T305704000	CAJA QUEMADOR	BURNER BOX	1	1			
25	T305706000	ESCUADRA AMARRE QUEMADOR	TIE BRACKET BURNER	1	1			
26	Z955801000	QUEMADOR F0000161	BURNER F0000161	1	1			
	Q032021000	TORNILLO ALOMADO M4X10	CURVED SCREW M4X10	2	2			
	Q242020000	ARANDELA ABANICO A4	FAN WASHER A4	2	2			
	Q162020000	TUERCA EXAGONAL M4	HEXAGONAL NUT M4	2	2			
27	Z952201000	VALVULA SIT 830.034 50 Hz	VALVE SIT 830.034 50 Hz	1	1			
27	Z953501000	VALVULA SIT 830.062 60 Hz	VALVE SIT 830.062 60 Hz	1	1			
28	S205023000	MANGUITO DOBLE 1/2	DOUBLE SLEEVE 1/2	1	1			
	Q221334000	TUERCA 1/2"	NUT 1/2"	2	2			
	U055043000	BICONO Ø12	BICONE Ø12	2	2			
29	T845019000	ENTRADA DE GAS COMP HGV P	COMP GAS INPUT HGV P	1	1			
	Q232040000	ARANDELA A6	WASHER A6	2	2			
	Q242040000	ARANDELA ABANICO A6 A.304	FAN WASHER A6 A.304	2	2			
	Q012042000	TORNILLO EXAGONAL M6X15	HEXAGONAL BOLT M6x15	2	2			
30	T305090000	TUBO DE GAS FLEXIBLE 300-90º	FLEXIBLE GAS PIPE 300-90º	1	1			
31	T305718500	ACOPLADOR COMPL. PINTADO	PAINTED COMPL. COUPLER	1	1			
	Z955807000	JUNTA CORCHO	CORK SEAL	1	1			
32	T305705000	TAPA CAJA	BOX COVER	1	1			
33	Z955803000	ELECTRODO DETECCION F1643600	DETECTION ELECTRODE F1643600	1	1			
	Q151320000	TOR. ALOMADO M4X6 H. ZINCADO	CURVED SCREW M4X6 H. ZINC-C	1	1			
34	Z955802000	ELECTRODO IGNICION F1643500	IGNITION ELECTRODE F1643500	1	1			
	Q151320000	TOR. ALOMADO M4X6 H. ZINCADO	CURVED SCREW M4X6 H. ZINC-C	1	1			

Зип Общепит

vsezip.ru

+7(812)987-08-81

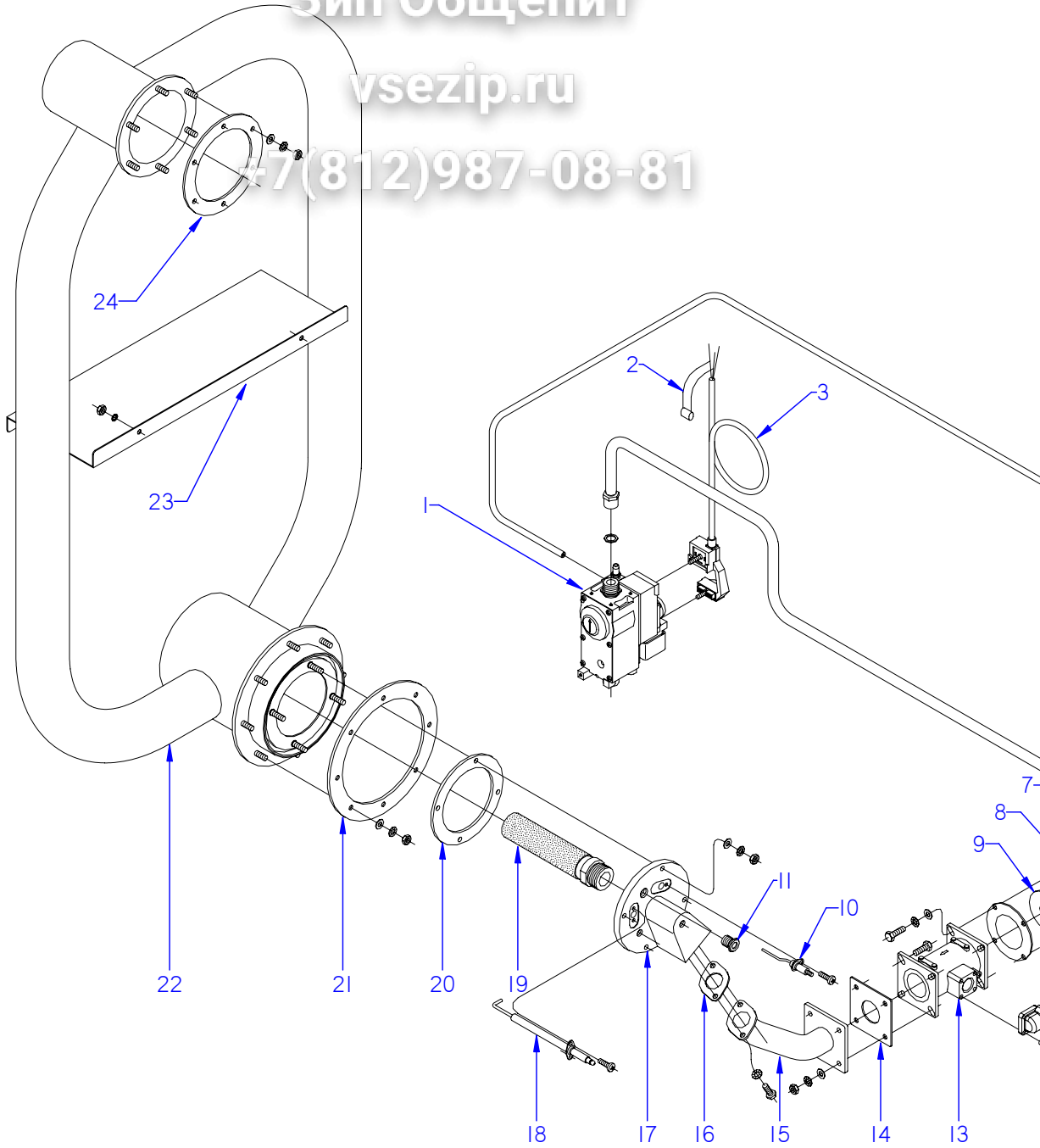

ITEM MARCADO EN COLOR = REPUESTO RECOMENDADO  
COLOURED ITEM = RECOMMENDED SPARE PART

N plano	Firma	Fecha	Aparato	Lamina	Ofrete
C-2759	<i>[Signature]</i>	2010-12	HORNOS COG / VG / VPG-201	10	Fagor Industrial S. Coop. <b>FAGOR</b>
PARTE FUNCIONAL GAS / FUNCTIONAL PART GAS					

MOD.		HORNOS / OVEN	ZONA / ZONE	PARTE FUNCIONAL GAS FUNCTIONAL PART GAS			
ITEM	CODIGO CODE	DENOMINACION	NAME	COG-201	VG-201	VPG-201	
1	T135037000	VALVULA REGUL. BP 50 Hz 20/11	CONTROL VALVE BP 50 Hz 20/11	1	1	1	
1	T135039000	VALVULA REGUL. GN 50 Hz 20/11	CONTROL VALVE GN 50 Hz 20/11	1	1	1	
1	T135040000	VALVULA REGUL. BP 60 Hz 20/11	CONTROL VALVE BP 60 Hz 20/11	1	1	1	
1	T135041000	VALVULA REGUL. GN 60 Hz 20/11	CONTROL VALVE GN 60 Hz 20/11	1	1	1	
S/Nº	R723013000	CONEXION VALVULA 960.107	VALVE CONNECTION 960,107	-	1	1	
S/Nº	R723016000	JUNTA CONEXION 830 960.108	CONNECTI. BOARD 830 960 108	-	1	1	
S/Nº	T085012000	CONECTOR VALVULA HONEYWELL	VALVE CONNECT. HONEYWELL	1	1	1	
2	Z233012000	CONDENSADOR ANTIPARASITARIO	ANTIPARASITIC CONDENSOR	1	3	3	
3	T085012000	CONECTOR VALVULA HONEYW.	HONEYW. VALVE CONNECTOR	1	1	1	
4	3702500000	TUBO GOMA NEGRO Ø 7*11	BLACK RUBBER PIPE Ø 7*11	1	1	1	
5	T115095000	MALLA VENTILADOR	FAN GRILLE	1	1	1	
	Q032021000	TORNILLO ALOMADO M4X10	CURVED SCREW M4X10	4	4	4	
	Q242020000	ARANDELA ABANICO A4	FAN WASHER A4	4	4	4	
6	T083000000	VENTILADOR E.B.M.-RG130	FAN E.B.M.-RG130	1	1	1	
7	T115081000	JUNTA ACOPLAMIENT. SOPLANTE	BLOWER COUPLING SEAL	2	2	2	
8	T115076000	ACOPLAMIEN. VENTILADOR MIXER	MIXER FAN COUPLING	1	1	1	
9	T135035000	ARANDELA Ø 22	WASHER Ø 22	1	1	1	
10	T135705000	ELECTRODO DETECCION 20/11	DETECTION ELECTRODE 20/11	1	1	1	
	Q153021000	TORNILLO ALOMADO M4 X 10	CURVED SCREW M4 X 10	2	2	2	
11	R725015000	VISOR DE ENCENDIDO	IGNITION WINDOW	1	1	1	
	R725063000	CRISTAL DE VISOR	WINDOW GLASS	1	1	1	
12	T305091000	TUBO DE GAS FLEXIBLE 850º	FLEXIBLE GAS PIPE 850 º	1	-	-	
12	T305092000	TUBO DE GAS FLEXIBLE 1300-90º	FLEXIBLE GAS PIPE 300-90 º	-	1	1	
13	T115075000	MIXER SIT 35KW	MIXER SIT 35KW	1	1	1	
14	T115079000	JUNTA MIXER	MIXER SEAL	1	1	1	
15	T115077000	CONDUCTO GAS TAPA PRINCIPAL	MAIN COVER GAS PIPE	1	1	1	
16	T095021000	JUNTA CONDUCTO	PIPE SEAL	1	1	1	
	Q012032000	TORNILLO EXAGONAL M5X15 A304	HEXAGONAL BOLT M5x15 A304	2	2	2	
	Q242030000	ARANDELA ABANICO A5 A.304	FAN WASHER A5 A.304	2	2	2	

MOD.		HORNOS / OVEN		ZONA / ZONE		PARTE FUNCIONAL GAS		FUNCTIONAL PART GAS	
ITEM	CODIGO CODE	DENOMINACION	NAME	COG-201	VG-201	VPG-201			
17	T115782000	TAPA PRINCIPAL	MAIN COVER	1	1	1			
	Q242030000	ARANDELA ABANICO A5 A.304	FAN WASHER A5 A.304	4	4	4			
	Q163030000	TUERCA EXAGONAL M5 LATON	HEXAGONAL NUT M5 BRASS	4	4	4			
18	T135706000	ELECTRODO IGNICION 20/11-20/21	IGNITION ELECTRODE 20/11-20/21	1	1	1			
	Q153021000	TORNILLO ALOMADO M4 X 10	CURVED SCREW M4 X 10	1	1	1			
19	T145712000	QUEMADOR FURIGAS 20/11	BURNER FURIGAS 20/11	1	1	1			
20	R725055000	JUNTA DE TAPA PRINCIPAL	MAIN COVER SEAL	1	1	1			
21	T145710000	JUNTA CAMARA COMBUST. 20/11	FUEL CHAMBER SEAL 20/11	1	1	1			
22	T155700000	INTERCAMBIADOR COMPL. 20/11	COMP. HEAT EXCHANGER 20/11	1	1	1			
	Q232040000	ARANDELA A6	WASHER A6	14	14	14			
	Q262040000	ARANDELA GROW. A6 A.304	WASHER GROW. A6 A.304	14	14	14			
	Q163040000	TUERCA EXAGONAL M6 LATON	HEXAGONAL NUT M6 BRASS	14	14	14			
23	T092615000	SEPARA CENTRAL 20-11/20-21	CENTRAL SEPARATOR 20-11/20-21	1	1	1			
	Q262040000	ARANDELA GROW. A6 A.304	WASHER GROW. A6 A.304	2	2	2			
	Q162040000	TUERCA EXAGONAL M6	HEXAGONAL NUT M6	2	2	2			
24	T145711000	JUNTA COLECTOR 20/11	MANIFOLD SEAL 20/11	2	2	2			
	Q232040000	ARANDELA A6	WASHER A6	4	4	4			
	Q242040000	ARANDELA ABANICO A6	FAN WASHER A6	4	4	4			
	Q162040000	TUERCA EXAGONAL M6	HEXAGONAL NUT M6	4	4	4			

Зип Общепит

vsezip.ru

+7(812)987-08-81

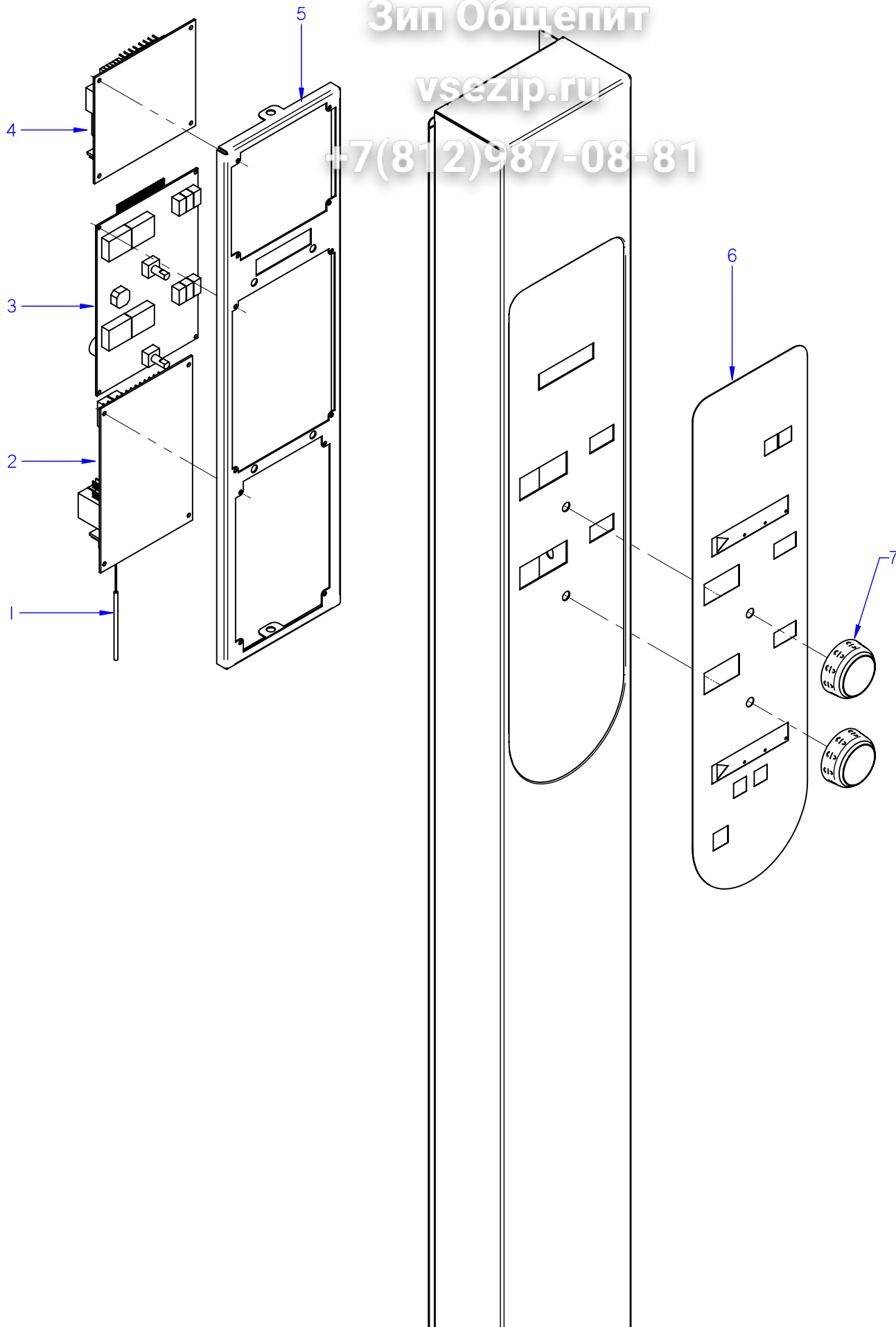

ITEM MARCADO EN COLOR = REPUESTO RECOMENDADO  
COLOURED ITEM = RECOMMENDED SPARE PART

N plano	Firma	Fecha	Aparato CONJUNTO ELECTR. PORTAMANDOS / CONTROL HOLDER ELECTRIC UNIT	Lamina	Fagor Industrial S.Coop. <b>FAGOR</b>
C-2760	<i>(Signature)</i>	2010-12	HORNOS COG-201	11	Oñate

+7(812)987-08-97

APARATO / APPLIANCE		HORNOS / OVENS		ZONA / ZONE		CONJUNTO ELECTRICO PORTAMANDOS CONTROL HOLDER ELECTRIC UNIT					
ITEM	CODIGO REFERENCE	DENOMINACION	DENOMINATION	COG-201							
1	T323011000	CONJUN. TERMOPAR CAMARA (K)	CHAMBER THERMOCOUPLE UNI	1							
2	T553003000	TARJETA CONTROL DE CAMARA	CHAMBER CONTROL CARD	1							
2	12097540	CONTROL TARJETA CAM.12V AC	CARD CONTROL 12V AC 50/60Hz	1							
	Q221026000	CLIP SUJECIÓN RÁPIDA Ø 4	RAPID CONNE RAPID RAPID RAP	4							
3	T533001000	TARJETA PORTAMANDOS HEI-HGC	CONTROL PANEL CARD	1							
3	12097547	VISUALIZADOR 12V AC 50/60Hz 12	12V AC 50/60Hz 12D DISPLAY	1							
	Q221026000	CLIP SUJECIÓN RÁPIDA Ø 4	RAPID CONNE RAPID RAPID RAP	4							
4	T553004000	TARJETA CONTROL DE GAS	CONTROL CARD GAS	1							
	Q221026000	CLIP SUJECIÓN RÁPIDA Ø 4	RAPID CONNE RAPID RAPID RAP	4							
5	T932802000	SOPORTE PROGRAMADOR	PROGRAM. SUPPORT	1							
	T732802000	DISTANCIAD. COMPONENTES 7mm	SPACER 7mm	4							
6	T933002000	SERIGRAFIA HGC 20/11	SERIGRAPHY HGC 20/11	1							
7	T903007000	BOTON DE MANDO	CONTROL BUTTON	2							

Зип Общепит

vsezip.ru

+7(812)987-08-81

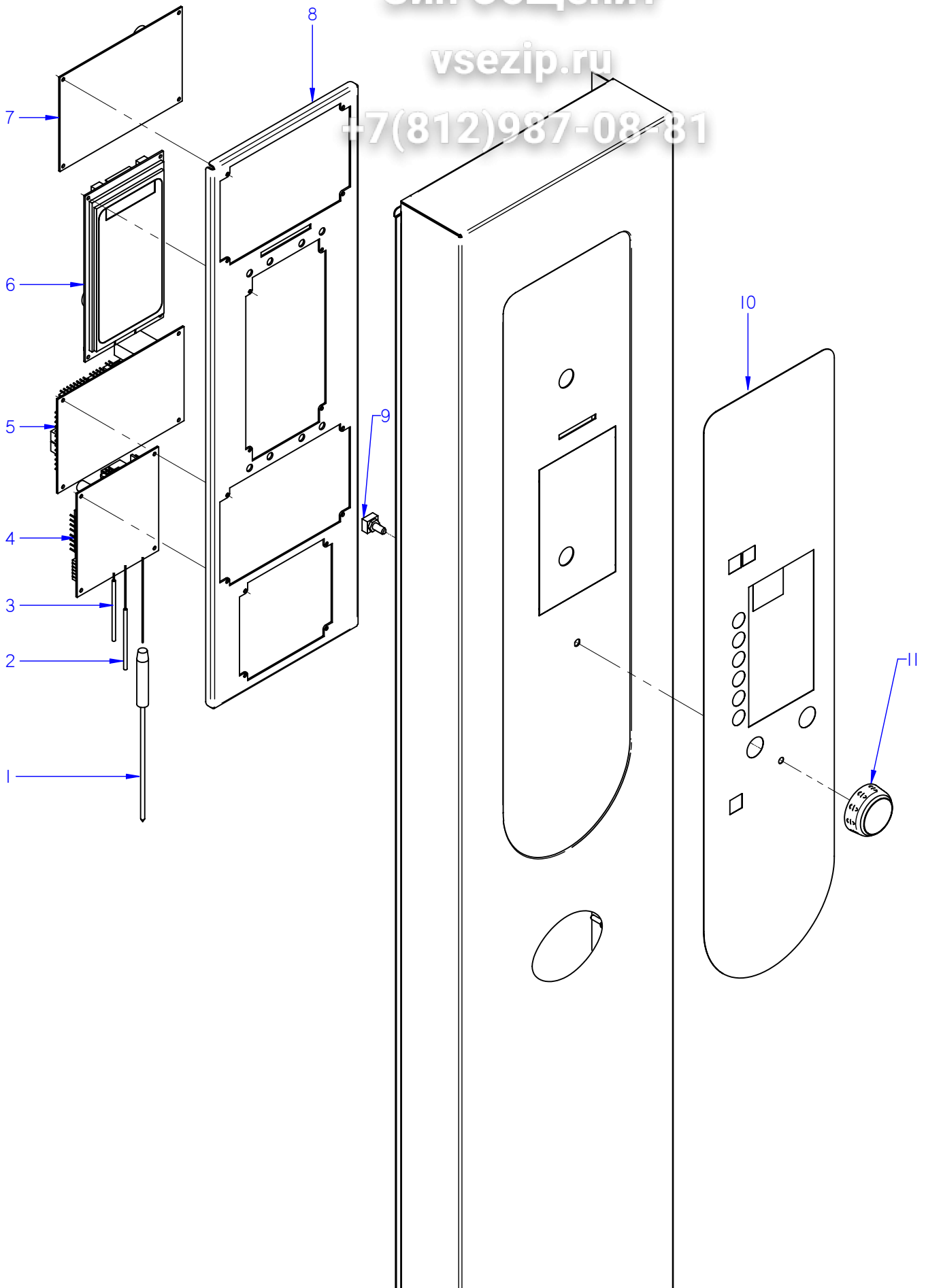

ITEM MARCADO EN COLOR = REPUESTO RECOMENDADO  
COLOURED ITEM = RECOMMENDED SPARE PART

N plano	Firma	Fecha	Aparato	CONJUNTO ELECTRICO PORTAMANDOS	Lamina	Fagor Industrial S.Coop. <b>FAGOR</b>
C-2761	<i>(Signature)</i>	2009-10	HORNOS VG-201		12	Oñate



APARATO / APPLIANCE		HORNOS / OVENS	ZONA / ZONE	CONJUNTO ELECTRICO PORTAMANDOS CONTROL HOLDER ELECTRIC UNIT					
ITEM	CODIGO REFERENCE	DENOMINACION	DENOMINATION	VG-201					
1	T623005000	CONJUNTO Sonda PARA NUCLEO	PROBE UNIT FOR CORE	1					
2	T323011000	CONJUN. TERMOPAR CAMARA (K)	CHAMBER THERMOCOUPLE UNI	1					
3	T323024000	CONJUN. TERMOPAR VAPOR 10/2	STEAM THERMOCOUPLE UNIT 1	2					
4	T553004000	TARJETA CONTROL DE GAS	CONTROL CARD GAS	1					
	Q221026000	CLIP SUJECIÓN RÁPIDA Ø 4	RAPID CONNE RAPID RAPID RAP	4					
5	T553003000	TARJETA CONTROL DE CAMARA	CHAMBER CONTROL CARD	1					
5	12097540	CONTROL TARJETA CAM.12V AC .	CARD CONTROL 12V AC 50/60Hz	1					
	Q221026000	CLIP SUJECIÓN RÁPIDA Ø 4	RAPID CONNE RAPID RAPID RAP	4					
6	T913003000	CIRC PORTAMANDOS HEM HGV	CONTROL HOLDER CIRCUIT HE	1					
6	12046658	VISUALIZADOR 12V AC 50/60Hz 32	12V AC 50/60Hz 32 D DISPLAY	1					
	Q221026000	CLIP SUJECIÓN RÁPIDA Ø 4	RAPID CONNE RAPID RAPID RAP	4					
7	T553002000	TARJETA CONTROL CALDERA	BOILER CONTROL CARD	1					
7	12097545	CONTROL TARJETA CALD. 12V AC	CARD CONTROL 12V AC 50/60Hz	1					
	Q221026000	CLIP SUJECIÓN RÁPIDA Ø 4	RAPID CONNECT CLIP Ø 4	8					
8	T842812000	SOPORTE CIRCUITOS HVG-10/11	CIRCUIT SUPPORT HVG-10/11	1					
	Q232030000	ARANDELA A5	WASHER A.5	4					
	Q221308000	TUERCA EXAGONAL AUT M5 H. ZI.	HEXAGONAL NUT M5 H. ZINC,	4					
9	T513009000	ENCODER GAMA VISUAL	VISUAL RANGE ENCODER	1					
10	T643003000	SERIGRAFIA VG	SERIGRAPHY VG	1					
11	T903007000	BOTON DE MANDO	CONTROL BUTTON	1					

Зип Общепит

vsezip.ru

77(812)987-08-81

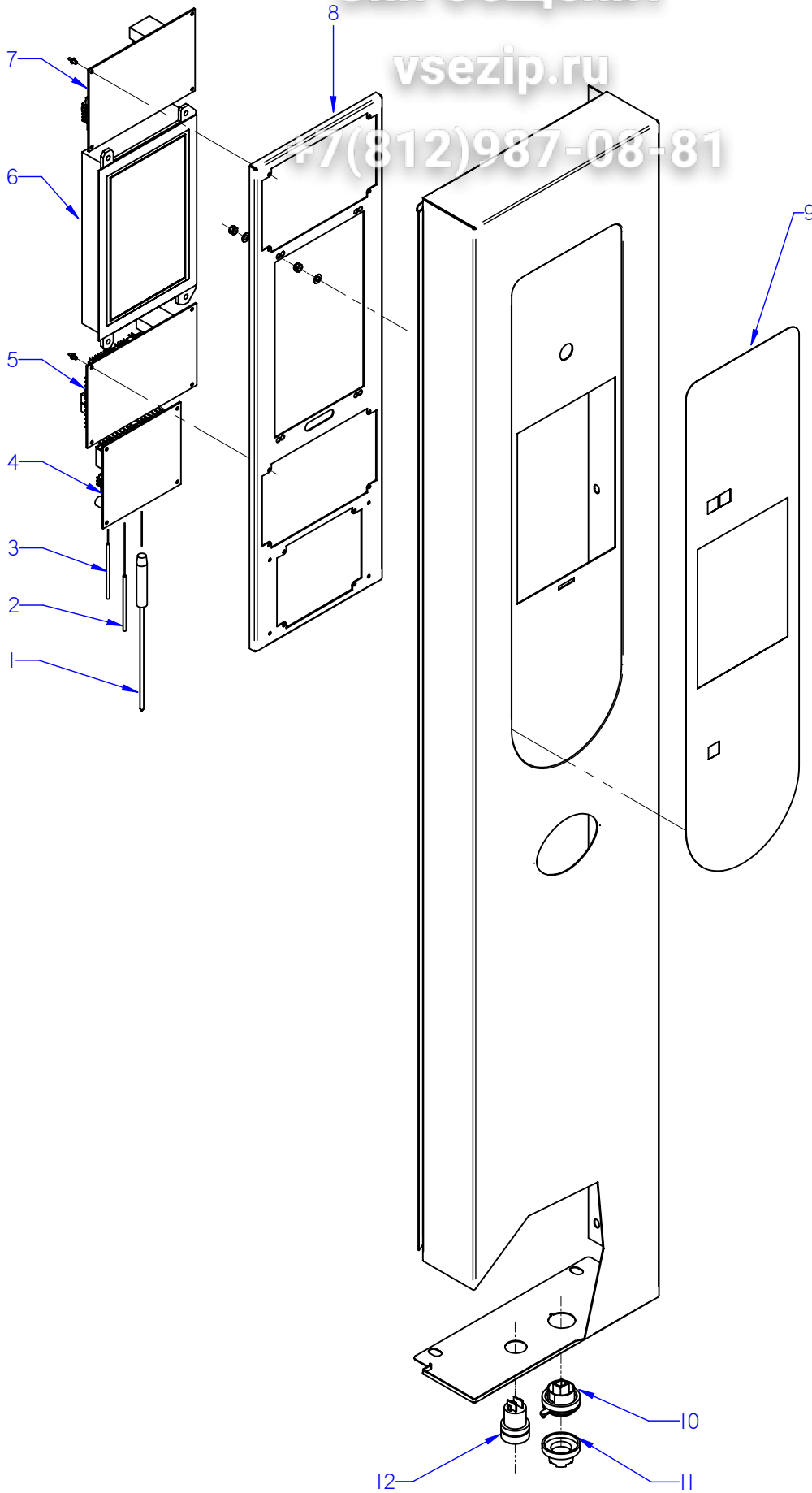

ITEM MARCADO EN COLOR = REPUESTO RECOMENDADO  
COLOURED ITEM = RECOMMENDED SPARE PART

N plano	Firma	Fecha	Aparato	CONJUNTO ELECTRICO PORTAMANDOS / CONTROL HOLDER ELECTRIC	Lamina	Fagor Industrial S.Coop. <b>FAGOR</b>
C-2762	<i>(Signature)</i>	2010-12	HORNOS VPG-201		13	Oñate

APARATO / APPLIANCE		HORNOS / OVENS		ZONA / ZONE		CONJUNTO ELECTRICO PORTAMANDOS CONTROL HOLDER ELECTRIC UNIT					
ITEM	CODIGO REFERENCE	DENOMINACION	DENOMINATION	VPG-201							
1	T823009000	CONJUN. Sonda NUCLEO 6 PUNT	PROBE UNIT FOR CORE	1							
2	T323011000	CONJUN. TERMOPAR CAMARA (K)	CHAMBER THERMOCOUPLE UNI	1							
3	T323024000	CONJUN. TERMOPAR VAPOR 10/2	STEAM THERMOCOUPLE UNIT 1	2							
4	T553004000	TARJETA CONTROL DE GAS	CONTROL CARD GAS	1							
	Q221026000	CLIP SUJECIÓN RÁPIDA Ø 4	RAPID CONNE RAPID RAPID RAP	4							
5	T553003000	TARJETA CONTROL DE CAMARA	CHAMBER CONTROL CARD	1							
5	12097540	CONTROL TARJETA CAM.12V AC .	CARD CONTROL 12V AC 50/60Hz	1							
	Q221026000	CLIP SUJECIÓN RÁPIDA Ø 4	RAPID CONNE RAPID RAPID RAP	4							
6	T553010000	PLATAFORMA VISUAL PLUS	VISUAL PLUS PLATFORM	1							
	Q032011000	TORNILLO ALOMADO M3x10	CURVED SCREW M.3x10	4							
	Q232010000	ARANDELA PLANA A3 DIN 125	WASHER A3 DIN 125	4							
	Q242010000	ARANDELA ABANICO A3 A.304	FAN SHAPED WASHER A.3	4							
	Q161310000	TUERCA EXAGONAL M3 H. ZINC,	HEXAGONAL NUT M3 H. ZINC,	4							
	Q221026000	CLIP SUJECIÓN RAPIDA Ø 4	RAPID CONNE RAPID RAPID RAP	4							
7	T553002000	TARJETA CONTROL CALDERA	BOILER CONTROL CARD	1							
7	12097545	CONTROL TARJETA CALD. 12V AC	CARD CONTROL 12V AC 50/60Hz	1							
	Q221026000	CLIP SUJECIÓN RAPIDA Ø 4	RAPID CONNE RAPID RAPID RAP	4							
8	T652804000	SOPORTE CIRCUITOS VPE VPG 21	SUPPORT CIRCUITS VPE VPG 21	1							
	Q232030000	ARANDELA A5	WASHER A.5	4							
	Q221308000	TUE.EX.AUT.M5 H.ZINCADA	HEXAGONAL NUT M5 H. ZINC,	4							
9	T853005000	SERIGRAFIA VPG-101 201	SERIGRAPHY VPG-101 201	1							
10	T723006000	CONECTOR USB VISUAL PLUS	VISUAL PLUS USB CONNECTOR	1							
11	T723007000	TAPA USB VISUAL PLUS	VISUAL PLUS USB COVER	1							
12	T723009000	PULSADOR SERIE MICRO	MICRO SWITCH SERIES	1							

Зип Общепит

vsezip.ru

+7(812)987-08-81

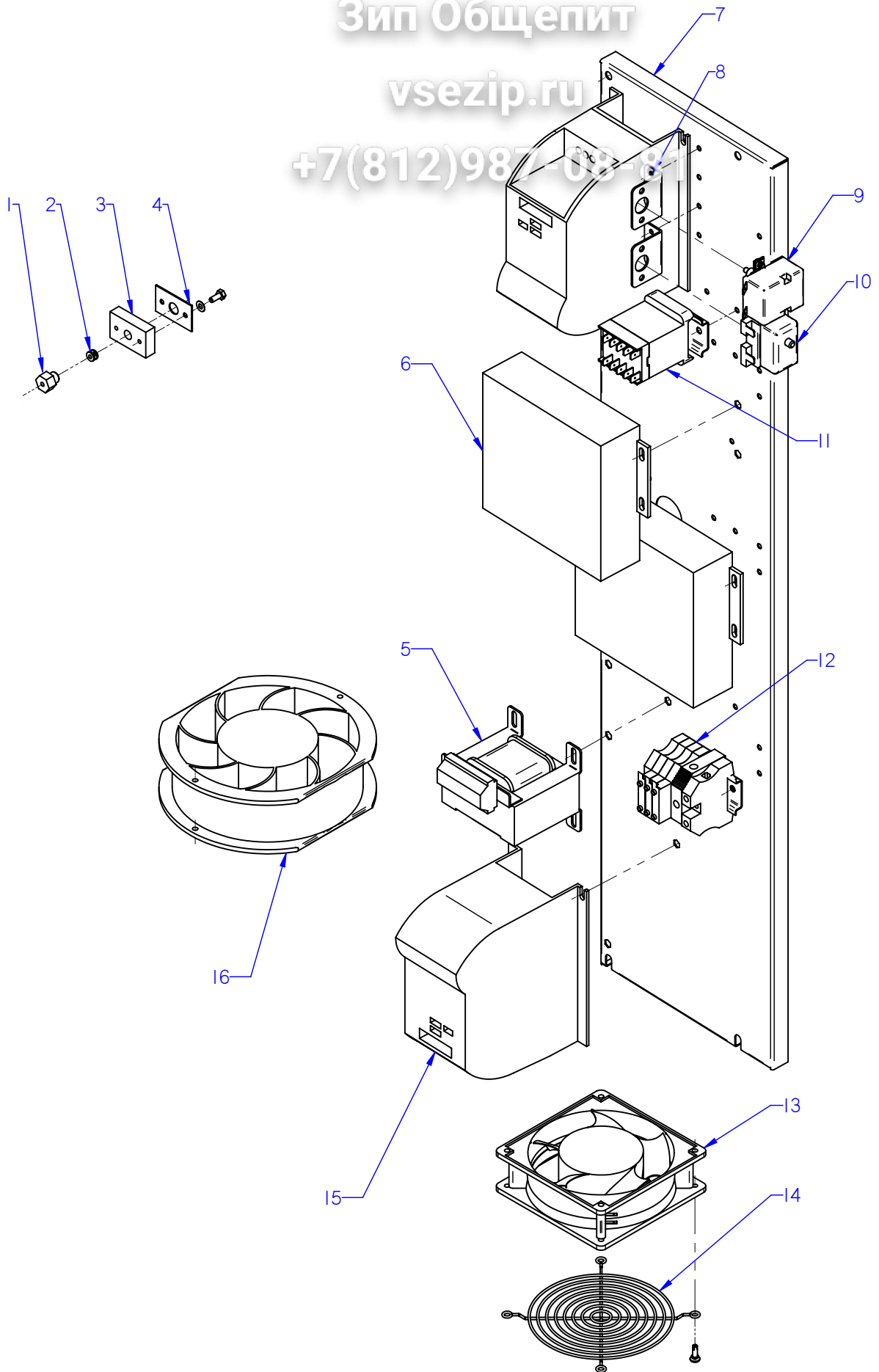

ITEM MARCADO EN COLOR = REPUESTO RECOMENDADO  
COLOURED ITEM = RECOMMENDED SPARE PART

N plano	Firma	Fecha	Aparato	Lamina	Fagor Industrial S.Coop. <b>FAGOR</b>
C-2763	<i>name (benf)</i>	2010-12	CUADRO ELECTRICO / ELECTRIC PANEL HORNOS COG / VG / VPG-201	14	Oñate

MOD.	HORNOS / OVEN	ZONA / ZONE	CUADRO ELECTRICO / ELECTRIC PANE					
ITEM	CODIGO CODE	DENOMINACION	NAME	COG-201	VG-201	VPG-201		
1	R662629000	RACORD CIERRE SONDA	PROBE CLOSING ADAPTOR	2	2	2		
S/Nº	R662662000	JUNTA CIERRE BULBO LIMITADOR	BULB LIMITER CLOSING SEAL	1	1	1		
2	R662652000	BICONO CIERRE SONDA	PROBE CLOSING BICONE	1	1	1		
3	T112625000	BASE CIERRE SONDA	FIXING CORE PROBE	2	2	2		
4	R692812000	JUNTA PASAMUROS SIMPLE	SIMPLE FEEDTHROUGH SEAL	2	2	2		
	Q232020000	ARANDELA A4	WASHER A.4	4	4	4		
	Q012021000	TORNILLO EXAGONAL M4X10	HEXAGONAL SCREW M.4X10	4	4	4		
5	R503005000	TRANSFORMADOR 230/12-0-12,0-1	TRANSFORMER 230/12-0-12,0-1	1	1	1		
5	R503005000	TRANSFORMADOR 230/12-0-12,0-1	TRANSFORMER 230/12-0-12,0-1	—	—	1		
5	T853002000	TRANSFORMADOR 12-0-12-0,24-0	TRANSFORMER 12-0-12-0,24-0	—	—	1		
6	Z953004000	CONTROL COMBUSTION	COMBUSTION CONTROL	1	2	2		
7	T733001000	CHAPA CUADRO ELECTRI VPE 201	SQUARE PLATE ELEC. VPE 201	1	—	—		
7	T723012000	CHAPA CUADRO ELECTRI VPE 201	SQUARE PLATE ELEC. VPE 201	—	1	1		
8	R343039000	SOPORTE TERMOS VAPOR	THERMOSTAT SUPPORT	1	2	2		
	Q412002000	REMACHE AVINOX Ø4x10MM	TUBULAR RIVET 4x7,5	2	4	4		
9	T303009000	TERMOSTATO LIMITADOR	THERMOSTAT LIMITER	1	1	1		
10	Z953035000	TERMOSTATO LIMITADOR AVISO	LIMITER THERMOSTAT WARNIN	—	1	1		
11	Z213007000	CONTACTOR 230V.50-60	230V.50-60 CONTACTOR	1	1	1		
12	P453026000	BORNE TIER 10 WPE-10103.O	10 WPE-10103.O EARTH TERM.	1	1	1		
	R073005000	BORNA PORTAFUSIBLES	FUSE HOLDER TERMINAL	2	2	2		
	Z263303000	TOPE FINAL	END BUFFER	1	1	1		
13	Z103066000	VENTILADOR 230V.50-60HZ	FAN 230V 50/60HZ	2	1	1		
14	T113015000	PROTECCION VENTILADOR	FAN PROTECTION	—	1	1		
	Q418021000	REMACHE PLASTICO Ø4 L7,5-8,5	PLASTIC RIVET Ø4 L7,5-8,5	—	4	4		
15	T323037000	VARIADOR FRECUENCIA SIE 0,37	FREQUENCY VARIATOR SIE 0.37	2	2	2		
	Q242020000	ARANDELA ABANICO A4 A.304	FAN SHAPED WASHER A.4	14	14	14		
	Q032021000	TORNILLO ALOMADO M4X10	CURVED SCREW M.4x10	14	14	14		



MOD.	HORNOS / OVEN	ZONA / ZONE	VARIOS / MISCELLANEOUS					
ITEM	CODIGO CODE	DENOMINACION	NAME	COG-201	VG-201	VPG-201		
	T936501000	MANUAL DE INSTRUCCION. COG	INSTRUCTIO. BROCHURE COG	1	-	-		
	T946501000	MANUAL DE INSTRUCCION. VG	INSTRUCTIO. BROCHURE VG	-	1	-		
	T956501000	MANUAL DE INSTRUCCION. VPG	INSTRUCTIO. BROCHURE VPG	-	-	1		
	T843007000	ESQU. TEORICO GAS 061-101-201	THE. DIAGRAM GAS 061-101-201	1	1	1		
	T833002000	PLANO MONTAJE COG	ASSEMBLY PLAN COG	1	-	-		
	T843008000	PLANO MONTAJE VG-201 VPG-201	ASSEMBLY PLAN VG-201 VPG-201	-	1	1		
	T303042000	LEYENDA HORNOS	LEGEND OVENS	1	1	1		
	T833004000	INSTAL. ELECTRICA 101	ELEC. INSTALL. 101	1	-	-		
	T843010000	INSTAL. ELECTRICA VG 101	ELEC. INSTALL. VG 101	-	1	1		
	T703008000	CABLEADO LUZ INTERIOR 20-11	INTERIOR LIGHT WIRING 20-11	1	1	1		
	T333009000	CABLEADO LAVADO HEP	WASH WIRING HEP	-	-	1		
	T853003000	CABLEADO TRANSFORMA. - TFT	TRANSFORMER WIRING - TFT	-	-	1		
	T723008000	CABLE USB VISUAL PLUS	VISUAL PLUS USB CABLE	-	-	1		
	T523004000	CABLEADO PULSADOR RESET	RESET BUTTON WIRING	-	-	1		
	T843005000	CABLEADO MOTOR	MOTOR WIRING	2	2	2		
	T743002000	CABLE. VARIADOR 201	VARIATOR WIRING201	1	1	1		
	T123010000	CABLE ENCENDIDO	ON WIRING	1	1	1		
	T133003000	CABLE ENCENDIDO HVG 20/11-21	ON WIRING HVG 20/11-21	-	1	1		
	T133033000	CABLE. VARIADOR SOPL. 20-11	VARIATOR WIRING SOPL. 20-11	1	1	1		
	T923016000	CABLEADO BMF	WIRING BMF	2	3	3		
	T722813000	CARRO 20-11 VISUAL COMPLETO	TROLLEY 20/11 VISUAL	-	1	1		
	T722817000	CARRO 20-11 VISUAL COMPLETO	TROLLEY 20/11 VISUAL	-	1	1		
	T542818000	RUEDA Ø 80 x 104	WHEEL Ø80 x 104	-	2	2		
	T542819000	RUEDA Ø 80 x 104 CON FRENO	WHEEL Ø80 x 104 WITH BRAKE	-	2	2		
	T492846000	ASA COMPLETA CARRO 20/21	HANDLE TROLLEY	-	1	1		

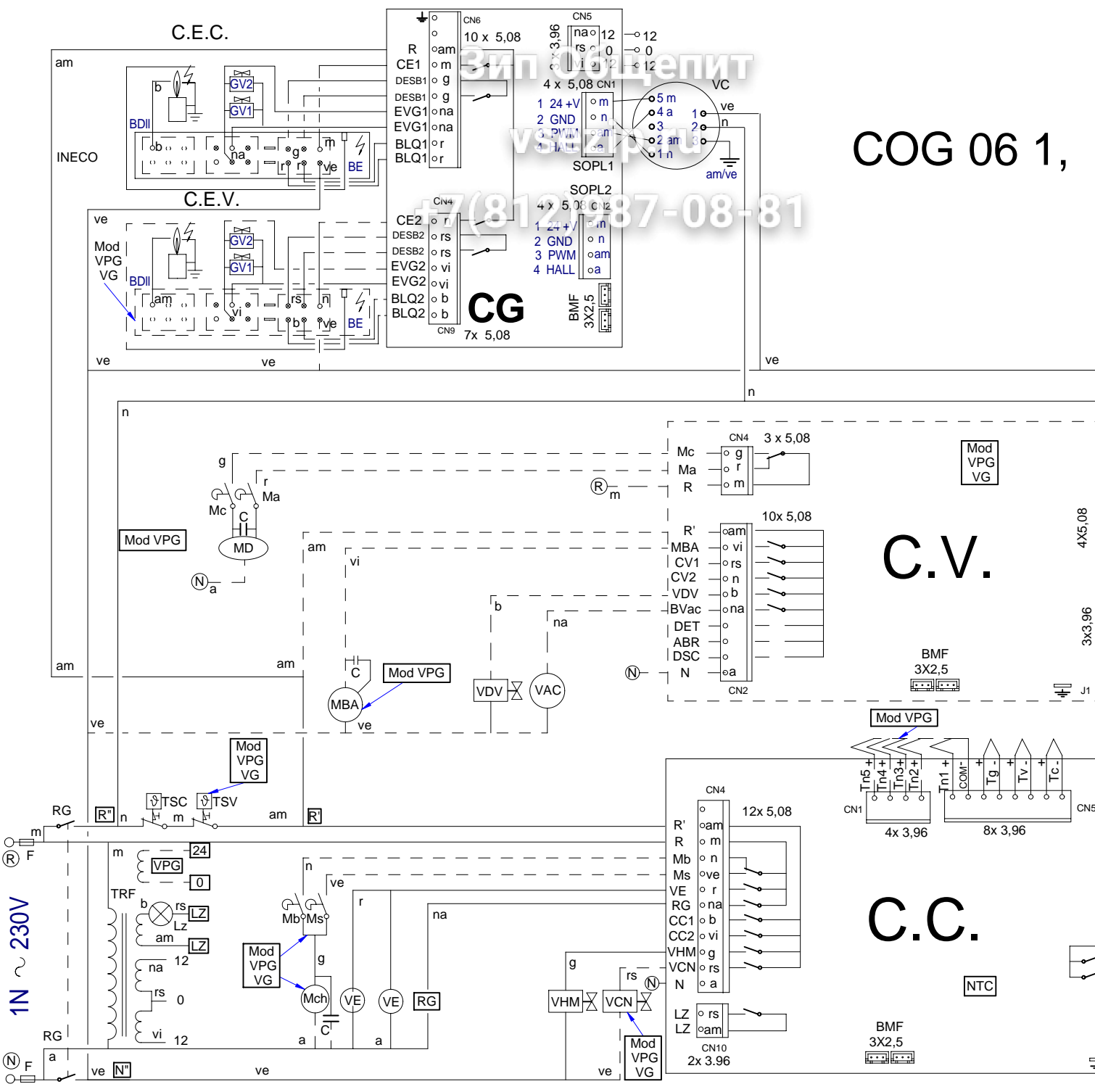

**C.E.C.**

**C.E.V.**

**C.V.**

**C.C.**

1N ~ 230V

Виподбелит  
виподбелит  
7(812)287-08-81

COG 06 1,

**CG**

Mod VPG VG

Mod VPG VG

Mod VPG VG

Mod VPG VG

Mod VPG VG

Mod VPG VG

Mod VPG VG

NTC

BMF 3X2,5

BMF 3X2,5

BMF 3X2,5



Зип Общепит

vsezip.ru

+7(812)987-08-81

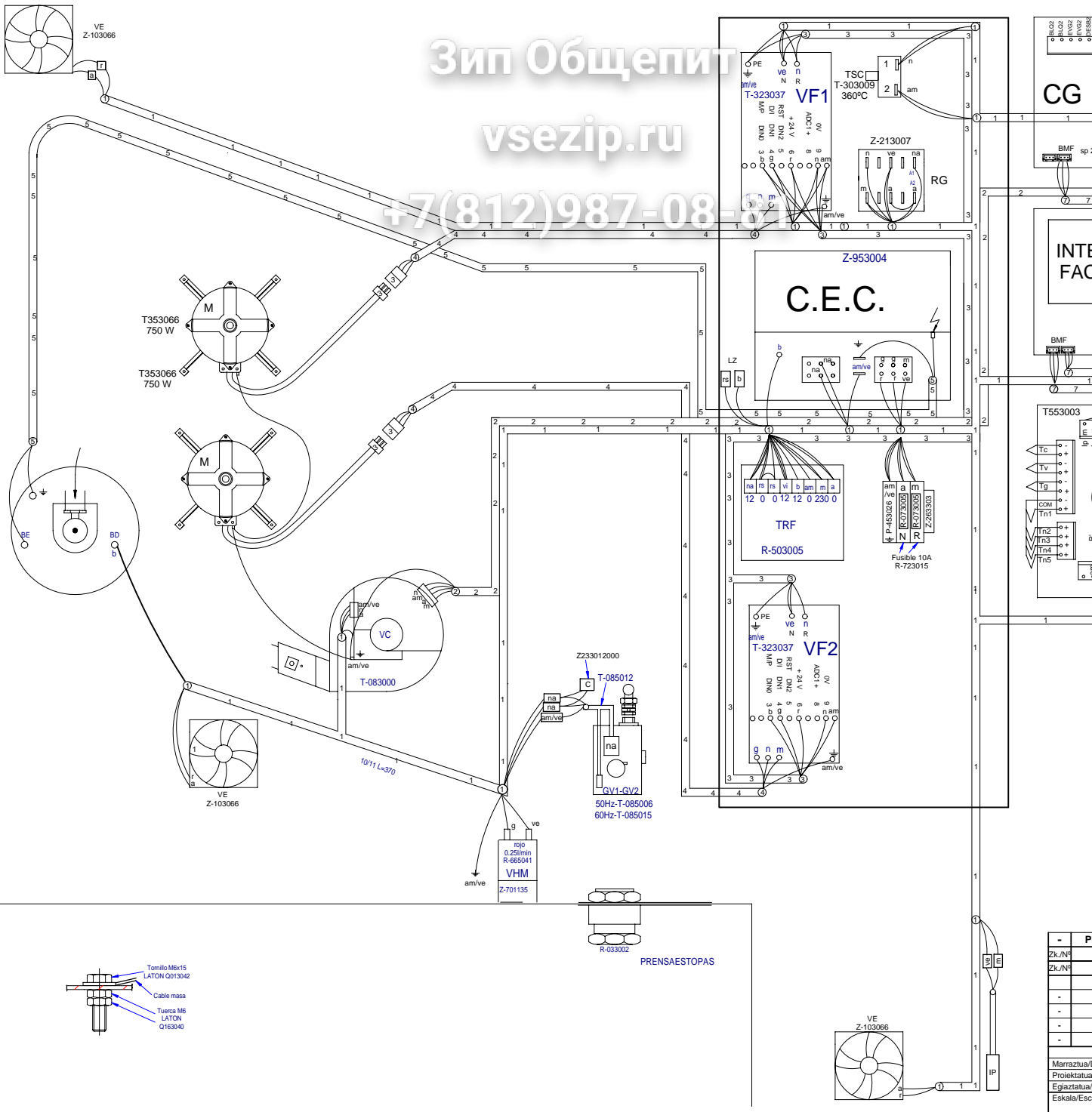

CG	BMF sp 2
INTE FAC	BMF
T553003	Tc Tv Tg Tnt
	COM Tn2 Tn3 Tn4
	IP

-	Pla
Zk./NF	
Zk./NF	
-	
-	
-	
-	
Marrastua/D	
Proiektatua/F	
Egiaztatua/C	
Eskala/Esca	

Зип Общежит  
vsezip.ru  
8(812)987-08-81

COPIAR PARAMETROS DESDE EL BOP AL VARIADOR  
P0003 = 3  
P001(= 9)  
P0 = 0 =  
NO USAR CUANDO EL BOP SE HA BORRADO  
P0802 desde Variador a BOP

Variable de Siemens.  
Pulsar [P] para entrar o salir de los Parametros.  
Nota: Si se modifica algun valor del nivel Basico, hay que volver a grabar el nivel 3.

P0010 = 1 Para inicio programación. (Nivel Basico)  
P0100 = 0 (Valor en KW 50Hz. Europa)  
P0304 = 230 (Vn V)  
P0305 = 1.8 (frec. A)  
P0307 = 0.37 (Ph KW)  
P0310 = 50 (Fm Hz)  
P0311 = 1400 (rpm Nom)  
P1000 = 2 (Terminal)  
P1001 = 50 (Consigna AOC)  
P1080 = 25 (F min Hz)  
P1082 = 50 (F Max Hz)  
P1120 = 5 (Ton °)  
P1121 = 5 (Ton °)  
P9800 = 1 (Fin de la programación y grabación de datos.)  
P0003 = 3 (Nivel 3 Español).  
P0005 = 27 (Visualización = Corriente de salida)  
P0811 = 16000 (Tiempo de activación de sobrecarga Seg.)  
P0840 = 150 (Sobrecarga de corriente en %)  
P1210 = 6 (Rearmado automático)  
P1300 = 2 (Modo Parado. Ventilador)  
P1800 = 16 (F Base KHz) (Cuantos mas alto = ruido acústico)  
P2000 = 50 (F Frecuencia de la consigna. Hz)

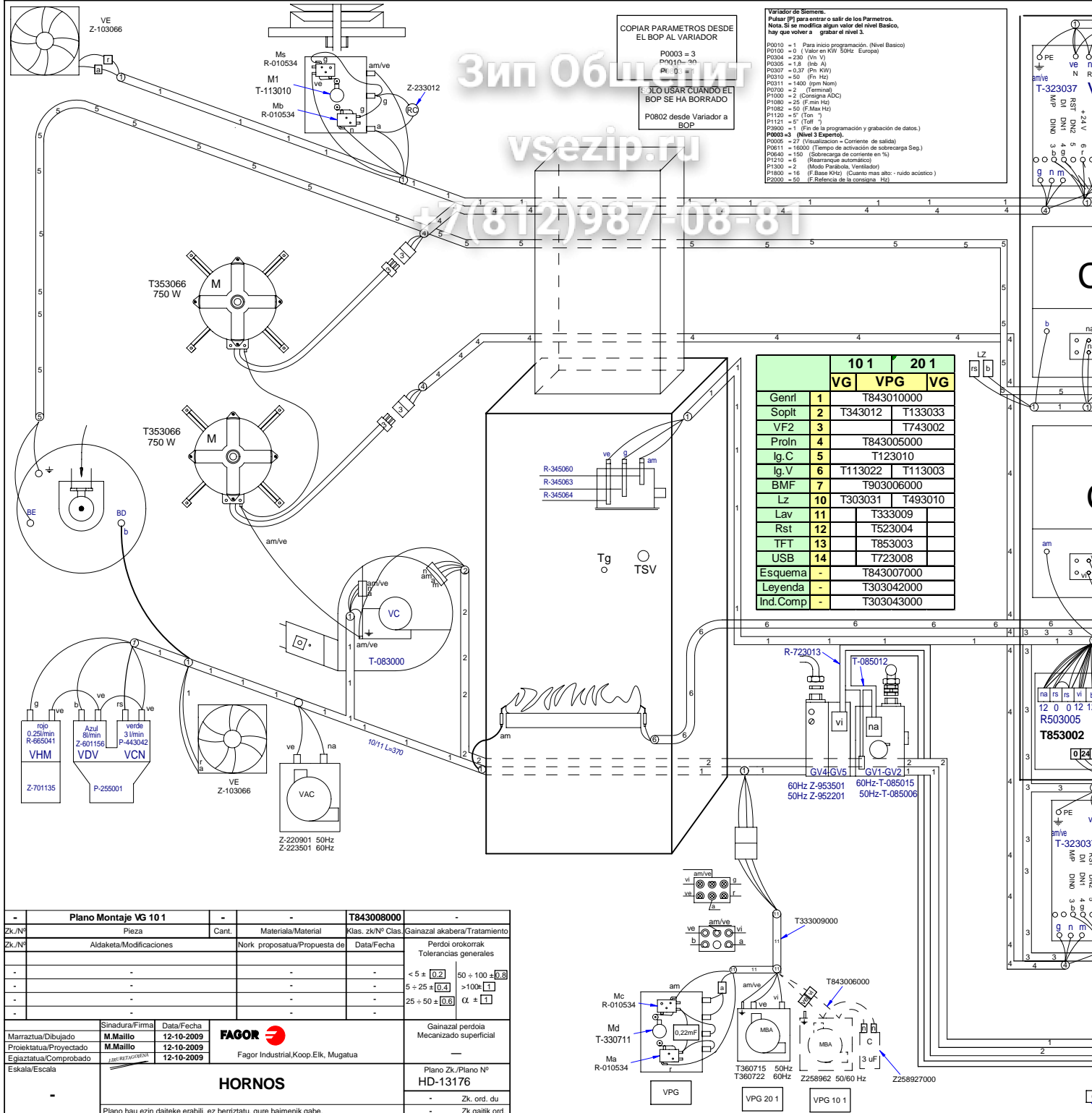

	101	201
	VG	VPG
Genrl	1	T843010000
Soplt	2	T343012 T133033
VF2	3	T743002
Proln	4	T843005000
lg.C	5	T123010
lg.V	6	T113022 T113003
BMF	7	T903006000
Lz	10	T303031 T493010
Lav	11	T333009
Rst	12	T523004
TFT	13	T853003
USB	14	T723008
Esquema	-	T843007000
Leyenda	-	T303042000
Ind.Comp	-	T303043000

Plano Montaje VG 101				T843008000	
Zk./Nº	Pieza	Cant.	Material/Material	Klas. zk/Nº Clas.	Gainazal akabera/Tratamiento
Zk./Nº	Aldaketa/Modificaciones		Nork proposatua/Propuesta de	Data/Fecha	Perdoi orokorrak Tolerancias generales
-	-	-	-	-	< 5 ± [0.2] 50 ± 100 ± [0.3]
-	-	-	-	-	5 ± 25 ± [0.4] > 100 ± [1]
-	-	-	-	-	25 ± 50 ± [0.6] α ± [1]
-	-	-	-	-	-
Marratzua/Dibujado	Sinadura/Firma <b>M.Maillo</b>	Data/Fecha <b>12-10-2009</b>	<b>FAGOR</b>	Gainazal perdoia Mecanizado superficial	
Proiektatua/Proyectado	<b>M.Maillo</b>	<b>12-10-2009</b>	Fagor Industrial,Koop.Elik, Mugatua	-	
Egiaztatua/Comprobado	<b>M.Maillo</b>	<b>12-10-2009</b>		Plano Zk./Plano Nº HD-13176	
Eskala/Escala				- Zk. ord. du	
				- Zk.galik ord.	

Plano hau ezin dateke erabili, ez berrizatu, gure baimenik gabe.

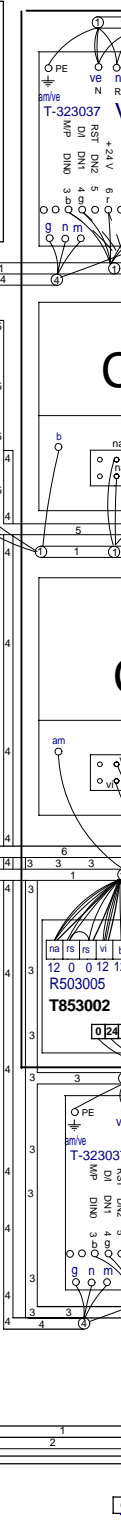

	ESPAÑOL	FRANÇAIS	ENGLISH	DEUTSCH
BEC	Bujía Encendido Cámara	Bougie Allumage Chambre	Chamber Spark Plug	Zündkerze Einschalten Ga
BEV	Bujía Encendido Caldera	Bougie Allumage Chaudière	Boiler Spark Plug	Zündkerze Einschalten Bo
C.C.	Control Camara	Contrôle Chambre	Chamber Control	Steuerung Garraum
C.E.C	Control Combustión Cámara	Contrôle Combustion Chambre	Chamber Combustion Control	Steuerung Verbrennung Ga
C.E.V	Control Combustión Caldera	Contrôle Combustion Chaudière	Boiler Combustion Control	Steuerung Verbrennung Bo
C.G.	Control Gas	Contrôle Gaz	Control Gas	Steuern Sie Gas
C.V.	Control Caldera	Contrôle Chaudière	Boiler Control	Steuerung Boiler
CC1, CC2	Contactador Resistencia Cámara	Contacteur Élément Chauffant Chambre	Chamber Heating Element Contactor	Schütz Heizwiderstand Ga
CK1, CK2	Contactador General Calentamiento	Relais Élément Chauffant	Heating Element Relay	Relais Heizwiderstand
CV1, CV2	Contactador Resistencias Caldera	Contacteur Élément Chauffant Chaudière	Boiler Heating Element Contactor	Schütz Heizwiderstand Bo
DEC	Detector Llama Cámara	Détecteur Flamme Chambre	Chamber Flame Detector	Flammendetektor Garraum
DEV	Detector Llama Caldera	Détecteur Flamme Chaudière	Boiler Flame Detector	Flammendetektor Boiler
DN	Detector Nivel Caldera	Détecteur Niveau Chaudière	Boiler Level Detector	Pegeldetektor Boiler
F	Fusibles	Fusibles	Fuses	Sicherungen
FI	Filtro Interferencias	Filtre Interférences	Interference Filter	Störungsfilter
FM	Térmico Motor	Thermique Moteur	Thermal Engine	Thermoschalter Motor
GV1, GV2	Electro válvula Gas Cámara	Électrovanne Gaz Chambre	Chamber Gas Solenoid Valve	Elektroventil Gas Garraum
GV3, GV4	Electro válvula Gas Caldera	Électrovanne Gaz Chaudière	Boiler Gas Solenoid Valve	Elektroventil Gas Boiler
Ip	Interruptor Seguridad Puerta	Interrupteur Sécurité Porte	Door Safety Switch	Sicherheitsschalter Tür
Lz	Luz Interior	Éclairage Intérieur	Inner Light	Innenbeleuchtung
M, M2	Motor Turbina	Moteur Turbine	Turbine Engine	Motor Turbine
Ma	Interruptor Micro Abierto	Microrupteur Ouvert	Open Microswitch	Mikroschalter Geöffnet
Mb	Interruptor Micro Bajada	Microrupteur Descente	Drop Microswitch	Mikroschalter Senken
Mc	Interruptor Micro Cerrado	Microrupteur Fermé	Closed Microswitch	Mikroschalter Geschlossen
Mch	Motor Chimenea	Moteur Cheminée	Stack Engine	Motor Abluftkamin
MD	Motor Desague	Moteur évacuation	Drain Engine	Motor Abfluss
Ms	Interruptor Micro Subida	Microrupteur Montée	Rise Microswitch	Mikroschalter Heben
PF	Potenciómetro Selector Funciones	Potentiomètre Sélecteur Fonctions	Functions Selector Potentiometer	Potentiometer Funktionsw
RC	Resistencias Cámara	Éléments Chauffants Chambre	Chamber Heating Element	Heizwiderstände Garraum
RG	Rele General	Relais Général	Main Relay	Hauptrelais
RV	Resistencias Caldera	Éléments Chauffants Chaudière	Boiler Heating Element	Heizwiderstände Boiler
Tc	Sonda Cámara	Sonde Chambre	Chamber Probe	Sonde Garraum
TCN	Termostato Condensación	Thermostat Condensation	Condensation Thermostat	Thermostat Kondensierung
Tg	Sonda Caldera	Sonde Chaudière	Boiler Probe	Sonde Boiler
Tn	Sonda Núcleo	Sonde Noyau	Core Probe	Kerntemperaturmesssonde
TRF	Transformador	Transformateur	Transformer	Transformator
TSC	Termostato Seguridad Cámara	Thermostat Sécurité Chambre	Chamber Safety Thermostat	Sicherheitsthermostat Gar
TSV	Termostato Seguridad Caldera	Thermostat Sécurité Chaudière	Boiler Safety Thermostat	Sicherheitsthermostat Boi
Tv	Sonda Vapor	Sonde Vapeur	Steam Probe	Sonde Dampf
VAC	Bomba Vaciado	Pompe Vidange	Vacuum Pump	Ablasspumpe
MBA	Moto Bomba Aclarado	Pompe Rinçage	Rinsing Pump	Pumpe Ausspülen
VC1, VC2	Ventilador Soplante Camara	Ventilateur Soufflant	Blowing Fan	Ventilator Gebläse
VCN	Electro válvula Condensación	Électrovanne Condensation	Condensation Solenoid Valve	Elektroventil Kondensierun
VDV	Electro válvula Llenado Caldera	Électrovanne Remplissage Chaudière	Chamber Filling Solenoid Valve	Elektroventil Füllung Boiler
VE	Ventilador Cuadro Eléctrico	Ventilateur Tableau Électrique	Fan Switchboard	Ventilator Elektrotafel
VF1, VF2	Variador de Frecuencia	Variateur Vitesse	Speed Variator	Geschwindigkeitsregler
VHM	Electro válvula Humidificador	Électrovanne Humidificateur	Humidifier Solenoid Valve	Elektroventil Befeuchtungs
Vv	Ventilador Soplante Caldera	Ventilateur soufflement chaudière	Boiler Blowing Fan	Durchbrennenventilator zur
	<b>COLORES</b>	<b>COULEURS</b>	<b>COLOUR</b>	<b>FARBEN</b>
a	Azul	Bleu	Blue	Blau
am	Amarillo	Jaune	Yellow	Gelb
am/ve	Amarillo/verde	Jaune / vert	Yellow / green	Gelb/grün
b	Blanco	Blanc	White	Weiß
g	Gris	Gris	Grey	Grau
m	Marrón	Marron	Brown	Braun
n	Negro	Noir	Black	Schwarz
na	Naranja	Orange	Orange	Orange
r	Rojo	Rouge	Red	Rot
rs	Rosa	Rose	Pink	Rosa
ve	Verde	Vert	Green	Grün
vi	Violeta	Violet	Purple	Violett