

Зип Общепит
vsezip.ru
+7(812)987-08-81

DESPIECES

ARMARIOS SNACK-700



Rev.: Oct-2012

Зип Общепит

RECAMBIOS
ARMARIOS SNACK-700
OCTUBRE-2012

FAGOR  vsezip.ru
FAGOFRI S.A.

+7(812)987-0881

Nº	CÓDIGO	DESCRIPCIÓN	MODELOS						
			AFP-701	AFP-702	AF-702-C	AF-702-P	AFN-702	AFN-701	AEP-701
1	6007050017	PATA REGULABLE ARM.GASTRO	4	4	4	4	4	4	4
2	6021130066	INTERRUPT. UNIPOL. NEGRO/ROJO							1
3	6021350113	SONDA NTC 2,5 MTS	1	1	3	2	2	2	1
4	A109010815	CABEZA AFP-700	1	1			1	1	1
4	A109010841	CABEZA AFP-700 DPTO			1	1			
5	6021130041	MICROR.CONMUT.E3111CA	1	1	1	1	1	1	1
6	6023010553	PEG.FAGOR GAMA CONCEPT	1	1			1	1	1
6	6023010554	PEG. FAGOR GAMA CONCEPT DPTO			1	1			
7	6021130065	INTERRUPTOR BIP. O/I NEGRO/ROJO	1	1	2	2	1	1	1
9	A177090018	CONJ.TERM. REF. 220v 50Hz	1	1	1	1			1
11	6029010146	BAT.6T4R300A4S PINTADO.ARMARIO	1	1					1
11	6029010160	BATERIA 4T 4R 300A 4S (PINTADO)			1	1			
11	6029010174	BAT. 6T 4R 300A 6S 2 CIRCUITO					1	1	
11	6029010014	EV.B14T2R426A6S DPTO.PESC PIN.				1			
11	6029010153	BAT. 6T 4R 300A 6S PINTADO			1				
12	A109250009	SUJ.VENT.AFP-700,800 COMPACTO	1	1	2	1	1	1	1
13	6021050066	VENTIL.EVAPOR.5W S/ARO S/PATAS	1	1	2	1	1	1	1
14	6027130004	REJILLA VENT.D.246 PINTADA	1	1	2	1	1	1	1
16	6003010033	DESAGÜE 1/2 PULG. CUELLO CORTO				1			
17	6003010175	CODO PVC MIXTO 90° 20x1/2				1			
18	6021010001	COMPR.SC-12-CL R404A			1				
18	6021010007	COMPRES.FR-8.5-G R134A	1	1					1
19	6029020008	CONDENSADOR 8X2 REF.C CT82DG			1	2			
19	6029020052	CONDENSADOR VENTILADO 139					1	1	
19	6029020013	CONDENSADOR 10X4 NEUTRO			1				
19	6029020002	CONDENSADOR 9X2	1	1					1
20	6021050004	VENTIL.5W PATA Y PALA DIAM.200			1	2			
20	6021050002	VENTILADOR 10W PATA PALA 220V	1	1	1				1
21	6003010023	BANDEJA EVAPORACIÓN AUTOMÁTICA	1	1	1		1	1	1
22	6021290052	REGLETA ELECTRONICA 8W	1	1	1	1			1
23	6003010184	CANALIZADOR AGUA 150 GRIS REFRIGERACION	1	1	1	1			1
24	6003010192	CANALIZADOR AGUA 150 NEGRO MANT.CONGEL.			1		1	1	
26	6027010087	PARRILLA 560x542 AR.SNACK	3	3	1	1	3	3	3
28	A109050445	CREMALL.INT.AFP-SNACK	2	2			2	2	2
28	A109050557	CREMALL.INT.DPTO.AF-702-C			2				
28	A109050559	CREMAL.INT.PEQ.EXT.DPTO			2	2			
29	A109050443	CREMALL.DEL.DCH.AFP-SNACK	1					1	1
29	A109050444	CREMAL.DEL.IZD.AFP-SNACK	1					1	1
29	A109050493	CREM.DELANT.DCH.PEQ.AFP		2	1	1	2		
29	A109050494	CREM.DELANT.IZD.PEQ.AFP		2	1	1	2		
29	A109050561	CREM.DEL.PEQ.AFP-GN DCHA.			2	2			
31	A109010857	REJILLA MOTOR 700 CONCEPT	1	1	1	1	1	1	1
32	A169010190	PUE PEQ AFP CONCEPT IZD		2	2	2	2		
32	A169010188	PUE CARN AFP/AFN CONCEPT IZD	1					1	
33	6045010131	BURLET.1457x636PUERT.CARN.	1					1	1
33	6045010132	BURLETE PUERT.PEQ.691x636		2	2	2	2		
35	6033010100	BIS.TR31D DOBL MUELLE DV-2608	1	2	2	2	2	1	1
38	A161130021	FRONTI HORZ.POST.AFP MAGNETICO		1			1		
38	A161130023	FRONTI HOR.POST.AF-700,800-C/P			1	1			
41	A133010000	SOP.BISAG.DV2607 INF IZQ. FRES		1	1	1	1		
42	6033010129	SOP.BISAG.INF.IZD.	1	1	1	1	1	1	1
43	6033010141	SOPORTE SUPERIOR BISAGRA IZQUIERDO	1	1	1	1	1	1	1
44	6033090104	EJE ROSCA EXT.30X10INOX		1	1	1	1		
45	6033090064	EJE SUP. PUERTAS 30x10 VARILLA INOX.INT. M-6	1	1	1	1	1	1	1
46	6003010136	CAJA ALOJAMIENTO MUELLE GRIS	1	2	2	2	2	1	1
47	6021010003	COMPR.TL-5-G R134A			1	2			
47	6021010002	COMPR.SC-15-CL R-404a					1	1	
48	6003050007	CUBETA DPTO PESCADO 530X460					3		
48	6003050006	CUBETA DPTO CONGEL.530X540			3				
49	A109050103	FOND.PERF.CUB.DPTO.530X460 AFP-SNACK					3		
50	A109050563	BANDEJA GOTEO DPTO.PESCADO					1		
51	A109250010	CUBRER.EVAP.FC61B ARM.COMPACTO	1	1	2	1	1	1	1
52	A109050562	DUELAS EVAP.DPTO.PESCADO 700/800/2100					1		
53	6021250051	RESIST.DESES.DEP.PESC.220V425W					1		
53	6021250019	RESIST.BLIND.FC61-71 350W 1000			1		1	1	

Зип Общепит

RECAMBIOS
ARMARIOS SNACK-700
OCTUBRE-2012

FAGOR  **vsezip.ru**
FAGOFRI S.A.

+7(812)987-08-81

Nº	CÓDIGO	DESCRIPCIÓN	MODELOS						
			AFP-701	AFP-702	AF-702-C	AF-702-P	AFN-702	AFN-701	AEP-701
54	6021250009	RESIST.MARCO EXT.700/800 43W			1		1	1	
55	6021250008	RESIST.FRONTI H.1400-1600 12W			1		1		
56	6033050010	GUIA SNACK DPTO.PESCADO 519mm				6			
56	6033050015	GUIA SNACK DPTO CONGEL.562mm			6				
57	6021350010	TERM CAREL CONG.PYCO1LO016			1	1	1	1	
58	6021250005	RESIST.BANDEJA 700-20W					1	1	
58	6021250011	RESIST.BANDEJA DEPART.18W			1				
60	6031070091	PT.CRISTAL ARM. 684x1505							1
62	6033010135	TIRAD. PT CRISTAL							1
71	6021010035	COND.ARRANQ.SC 117U5017 80MF			1		1	1	
71	6021010036	CONDEN.ARRANQUE TL-G 17U5014 60 mF			1	2			
71	6021010037	CONDEN.ARRANQUE FR-117U5015 80 mF	1	1					1
73	6021010042	RELE ARRANQUE COMPRESOR SC-12CL			1				
73	6021010043	RELE ARRANQ COMPR.SC-15CL 6019					1	1	
73	6021010044	RELE ARRANQUE COMPRESOR TL-5G 6000			1	2			
73	6021010025	RELE ARRANQUE COMPRESOR FR-8,5G 2	1	1					1
80	A171010106	UD.EVAP.AFP-700,800,APP COMPAC	1	1					1
80	A171010120	UD.EV.AFP700,800-C/P COMP.FRIO			1	1			
81	A171010135	UD. EV. AFN-700,800 CONCEPT					1	1	
81	A171010128	UND. EVAP. AF-700-C COMPACT			1				

Зип Общепит

LISTADO MODIFICACIONES RESPECTO A ACTUALIZACION Feb-2012

Nº	Mar-2011		Oct-2012		RELACION
	CODIGO	DESCRIPCION	CODIGO	DESCRIPCION	
2	6021130002	INTERRUPTOR UNIPOL.LUMINOS.AMB	6021130066	INTERRUPTOR UNIPOL. NEGRO/ROJO	INTERCAMBIABLE
3	6021350021	SONDA CAREL NTC030HP00 3MT	6021350113	SONDA NTC 2,5 MTS	INTERCAMBIABLE
4	A109010442	CABEZA AFP-700	A109010815	CABEZA AFP-700	NO INTERCAMBIABLE
4	A109010459	CABEZA AFP-700 DPTO	A109010841	CABEZA AFP-700 DPTO	NO INTERCAMBIABLE
6	6023010408	PEG.CUAD.FAGOR REFR.347,5X60	6023010553	PEG.FAGOR GAMA CONCEPT	NO INTERCAMBIABLE
6	6023010406	PEG.CUAD.FAG ARMAR.DPTO	6023010554	PEG. FAGOR GAMA CONCEPT DPTO	NO INTERCAMBIABLE
7	6021130001	INT.BIP.AMB.O/I CONTAC.REFORZ.	6021130065	INTERRUPTOR BIP. O/I NEGRO/ROJO	INTERCAMBIABLE
8	6021130002	INTERRUPTOR UNIPOL.LUMINOS.AMB	6021130066	INTERRUPTOR UNIPOL. NEGRO/ROJO	INTERCAMBIABLE
9	6021350018	TERMOS REFRI CAREL PYCO1SN515	A177090018	CONJ.TERM. REF. 220v 50Hz	INTERCAMBIABLE
31	A109010443	REJILLA MOTOR 700	A109010857	REJILLA MOTOR 700 CONCEPT	INTERCAMBIABLE
32	A169010090	PUE PEQ AFP/AFN IZD	A169010190	PUE PEQ AFP CONCEPT IZD	INTERCAMBIABLE
32	A169010081	PUE CAR AFP/AFN IZD	A169010188	PUE CARN AFP/AFN CONCEPT IZD	INTERCAMBIABLE
57	6021350010	TERM CAREL CONG.PYCO1LO016	A177090020	CONJ. TERM.CONG. 220v 50Hz	INTERCAMBIABLE
60	6031070067	PUERT. CRIST. AFP IZQ.	6031070091	PT. CRISTAL ARM 684x1505	NO INTERCAMBIABLE
62	6033010002	TIRADOR ASA CROMADA	6033010135	TIRAD. PT. CRISTAL	NO INTERCAMBIABLE
81	A171010108	UD.EVAP.AFN-700,800,AP COMPACT	A171010135	UND. EV. AFN-700,800 CONCEPT	NO INTERCAMBIABLE

Зип Общепит

vsezip.ru

+7(812)987-08-81

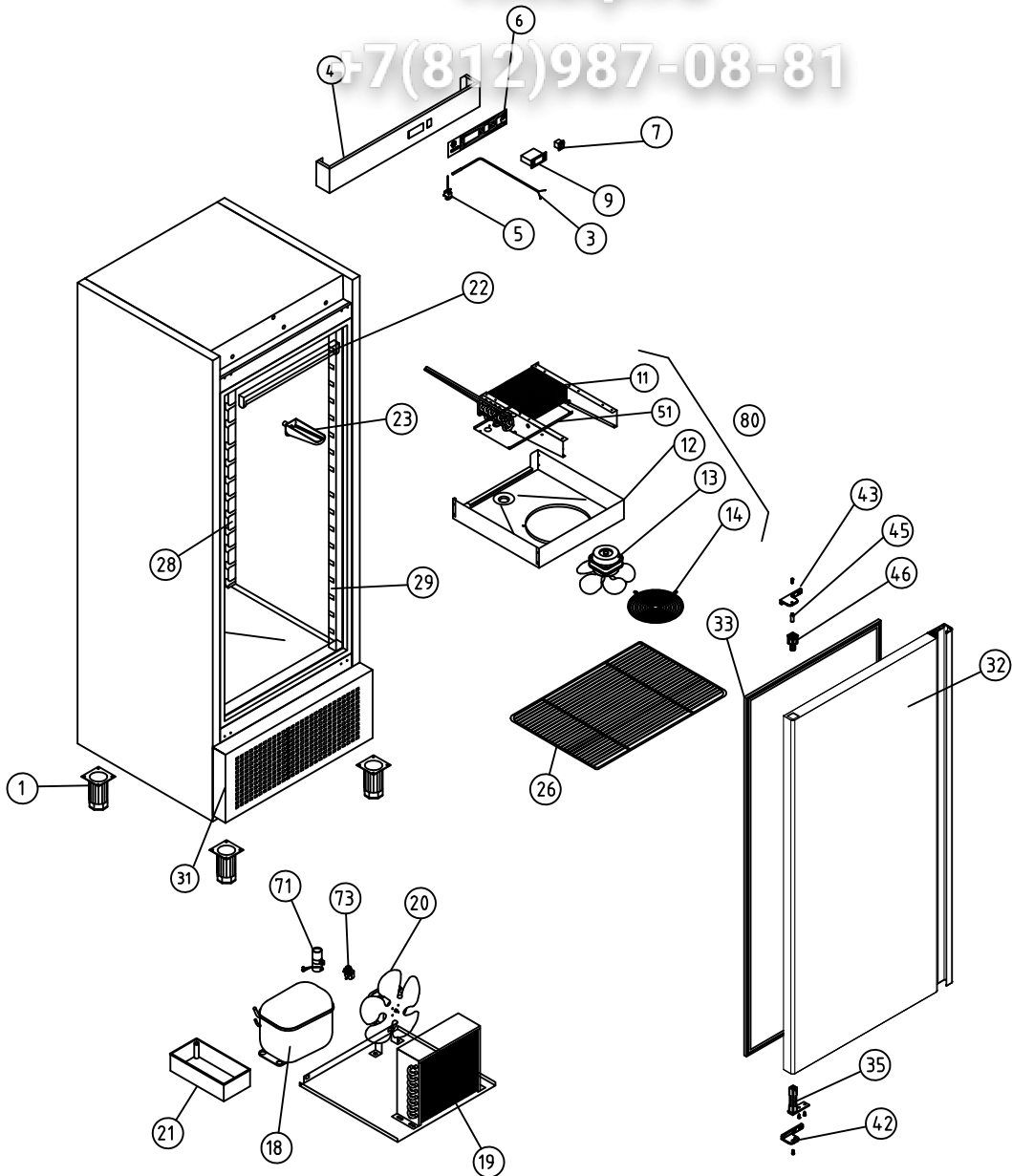

A1 ARMARIOS SNACK

COD. PIEZA:

X

COTAS SIN TOLERANCIA DIN 7168-f

Material: MATERIAL ESPESOR

SUSTITUYE A:

.

GRADO TOLERANCIA	FINO	MEDIO	GRUESO
HASTA 10 mm		±1°	±1° 30'
MAS DE 10 A 50 mm	±30'		±50'
MAS DE 50 A 120 mm	±20'		±25'
MAS DE 120 A 400 mm	±10'		±15'
MAS DE 400 mm	±5'		±10'

Acabado: ACABADO

SUSTITUIDO POR:

.

ANGULAR	COMUN A	MODELO	Ud.	MODELO	Ud.	MODELO	Ud.	MODELO	Ud.	MODELO	Ud.
		AFP-701	1								

ANGULAR	COMUN A	MODELO	Ud.	MODELO	Ud.	MODELO	Ud.	MODELO	Ud.	MODELO	Ud.
		AFP-701	1								

GRADO TOLERANCIA	FINO	MEDIO	GRUESO
HASTA 3 mm	±0,05	±0,10	±0,15
MAS DE 3 A 6 mm	±0,05	±0,10	±0,20
MAS DE 6 A 30 mm	±0,10	±0,20	±0,50
MAS DE 30 A 120 mm	±0,15	±0,30	±0,80
MAS DE 120 A 400 mm	±0,20	±0,50	±1,20
MAS DE 400 A 1000 mm	±0,30	±0,80	±2,00
MAS DE 1000 A 2000 mm	±0,50	±1,20	±3,00

A4	Nombre	Fecha	 <p>Fagofri, s.a.</p>
Dibujado	A.J.GONZALEZ	.21-10-10	
Modificado	B. MORENO	Oct-2012	
Escala	1:30		

RECAMBIOS AFP-701

Código máquina:

CODIGO

Зип Общепит

vsezip.ru

+7(812)987-08-81

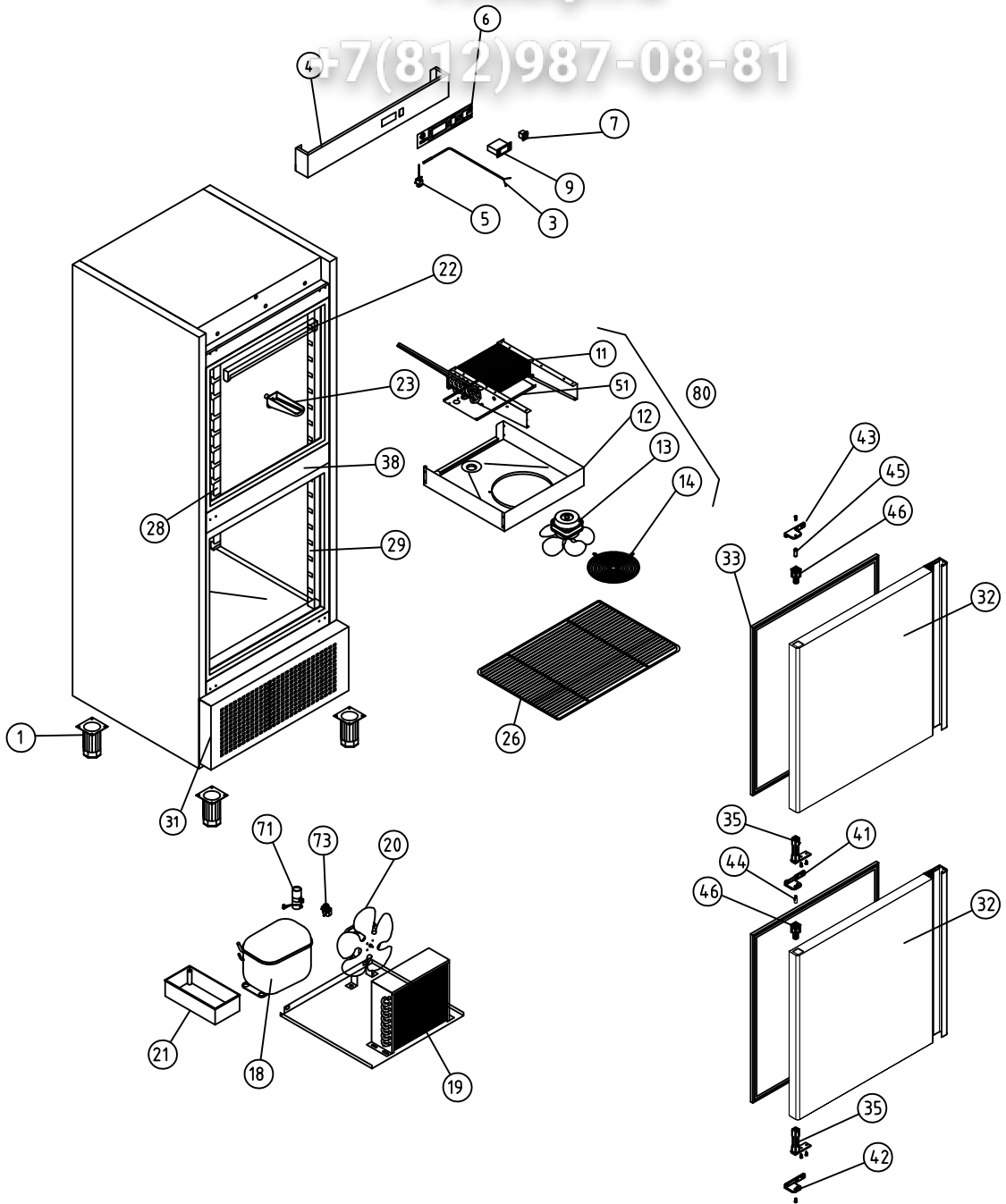

A1 ARMARIOS SNACK

COD. PIEZA:

X

COTAS SIN TOLERANCIA DIN 7168-f

Material: MATERIAL ESPESOR

SUSTITUYE A:

ANGULAR	GRADO TOLERANCIA	FINO	MEDIO	GRUESO
	HASTA 10 mm		±1°	±1° 30'
	MAS DE 10 A 50 mm	±30'		±50'
	MAS DE 50 A 120 mm	±20'		±25'
	MAS DE 120 A 400 mm	±10'		±15'
MAS DE 400 mm	±5'		±10'	

Acabado: ACABADO

SUSTITUIDO POR:

COMUN A	MODELO	Ud.	MODELO	Ud.	MODELO	Ud.	MODELO	Ud.	MODELO	Ud.
		AFP-702	1							

LINEAL	GRADO TOLERANCIA	FINO	MEDIO	GRUESO
	HASTA 3 mm	±0,05	±0,10	±0,15
	MAS DE 3 A 6 mm	±0,05	±0,10	±0,20
	MAS DE 6 A 30 mm	±0,10	±0,20	±0,50
	MAS DE 30 A 120 mm	±0,15	±0,30	±0,80
	MAS DE 120 A 400 mm	±0,20	±0,50	±1,20
MAS DE 400 A 1000 mm	±0,30	±0,80	±2,00	
MAS DE 1000 A 2000 mm	±0,50	±1,20	±3,00	

A4	Nombre	Fecha
Dibujado	A.J.GONZALEZ	.21-10-10
Modificado	B. MORENO	Oct-2012



Escala	RECAMBIOS AFP-702	Código máquina:
1:30		CODIGO

Зип-Общепит

zipsezip.ru

+7(812)987-08-81

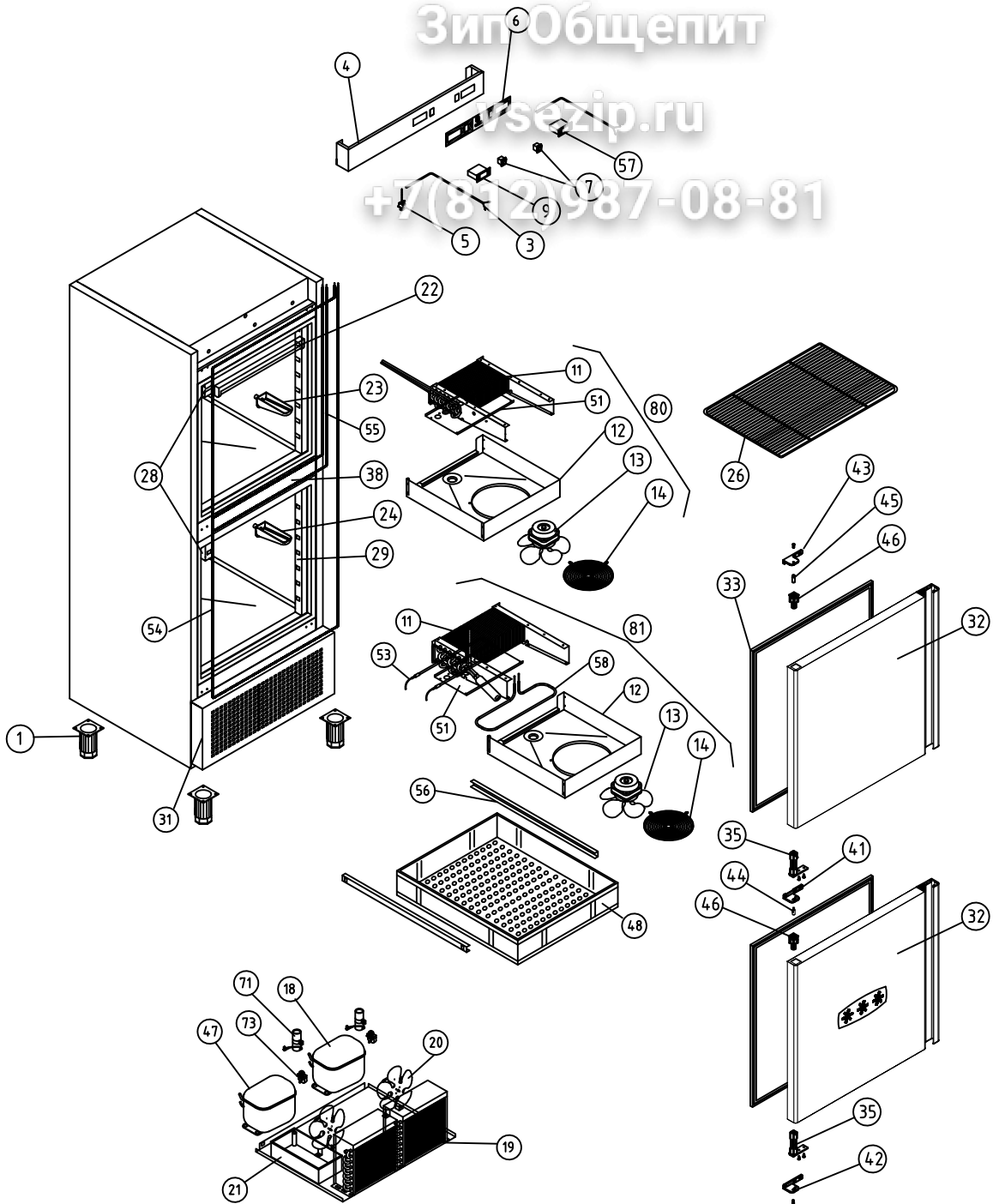

A1 ARMARIOS SNACK DEPARTAMENTO MANTENIMIENTO CONGELADOS

COD. PIEZA: X

COTAS SIN TOLERANCIA DIN 7168-f

Material: MATERIAL ESPESOR

SUSTITUYE A:

Acabado: ACABADO

SUSTITUIDO POR:

ANGULAR	GRADO TOLERANCIA	FINO	MEDIO	GRUESO
	HASTA 10 mm		±1°	±1° 30'
	MAS DE 10 A 50 mm		±30'	±50'
	MAS DE 50 A 120 mm		±20'	±25'
	MAS DE 120 A 400 mm		±10'	±15'
MAS DE 400 mm		±5'	±10'	

COMUN A	MODELO	Ud.	MODELO	Ud.	MODELO	Ud.	MODELO	Ud.	MODELO	Ud.
		AF-702-C	1							

LINEAL	GRADO TOLERANCIA	FINO	MEDIO	GRUESO
	HASTA 3 mm	±0,05	±0,10	±0,15
	MAS DE 3 A 6 mm	±0,05	±0,10	±0,20
	MAS DE 6 A 30 mm	±0,10	±0,20	±0,50
	MAS DE 30 A 120 mm	±0,15	±0,30	±0,80
MAS DE 120 A 400 mm	±0,20	±0,50	±1,20	
MAS DE 400 A 1000 mm	±0,30	±0,80	±2,00	
MAS DE 1000 A 2000 mm	±0,50	±1,20	±3,00	

A4	Nombre	Fecha
Dibujado	A.J.GONZALEZ	.21-10-10
Modificado	B. MORENO	Oct-2012



Escala	RECAMBIOS AF-702-C	Código máquina:
1:30		CODIGO

Зип-Общепит

zipsezip.ru

+7(812)987-08-81

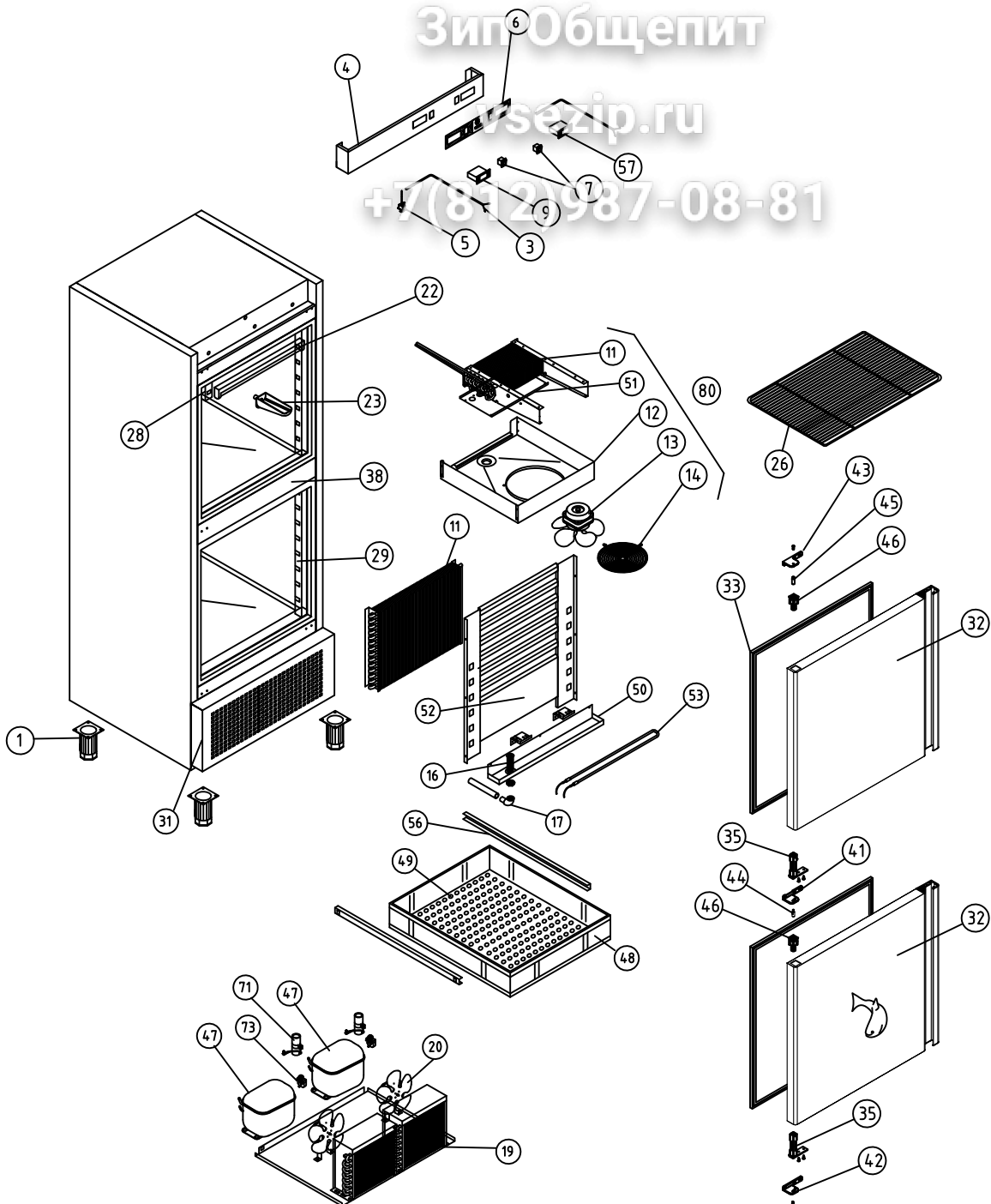

A1 ARMARIOS SNACK DEPARTAMENTO PESCADO COD. PIEZA: X

COTAS SIN TOLERANCIA DIN 7168-f SUSTITUYE A:

Material: MATERIAL ESPESOR SUSTITUIDO POR:

Acabado: ACABADO

ANGULAR	GRADO TOLERANCIA	FINO	MEDIO	GRUESO	COMUN A	MODELO	Ud.	MODELO	Ud.	MODELO	Ud.	MODELO	Ud.	MODELO
	HASTA 10 mm		±1°			±1° 30'	AF-702-P	1						
MAS DE 10 A 50 mm		±30'		±50'										
MAS DE 50 A 120 mm		±20'		±25'										
MAS DE 120 A 400 mm		±10'		±15'										
MAS DE 400 mm		±5'		±10'										

LINEAL	GRADO TOLERANCIA	FINO	MEDIO	GRUESO	A4		FAGOR	
	HASTA 3 mm		±0,05	±0,10	±0,15	Nombre	Fecha	
MAS DE 3 A 6 mm		±0,05	±0,10	±0,20	Dibujado	A.J.GONZALEZ .21-10-10		
MAS DE 6 A 30 mm		±0,10	±0,20	±0,50	Modificado	B. MORENO Oct-2012		

MAS DE 30 A 120 mm	±0,15	±0,30	±0,80	Escala	RECAMBIOS AF-702-P	Código máquina: CODIGO
MAS DE 120 A 400 mm	±0,20	±0,50	±1,20	1:30		
MAS DE 400 A 1000 mm	±0,30	±0,80	±2,00			
MAS DE 1000 A 2000 mm	±0,50	±1,20	±3,00			

Зип Общепит

vsezp.ru

+7(812)987-08-81

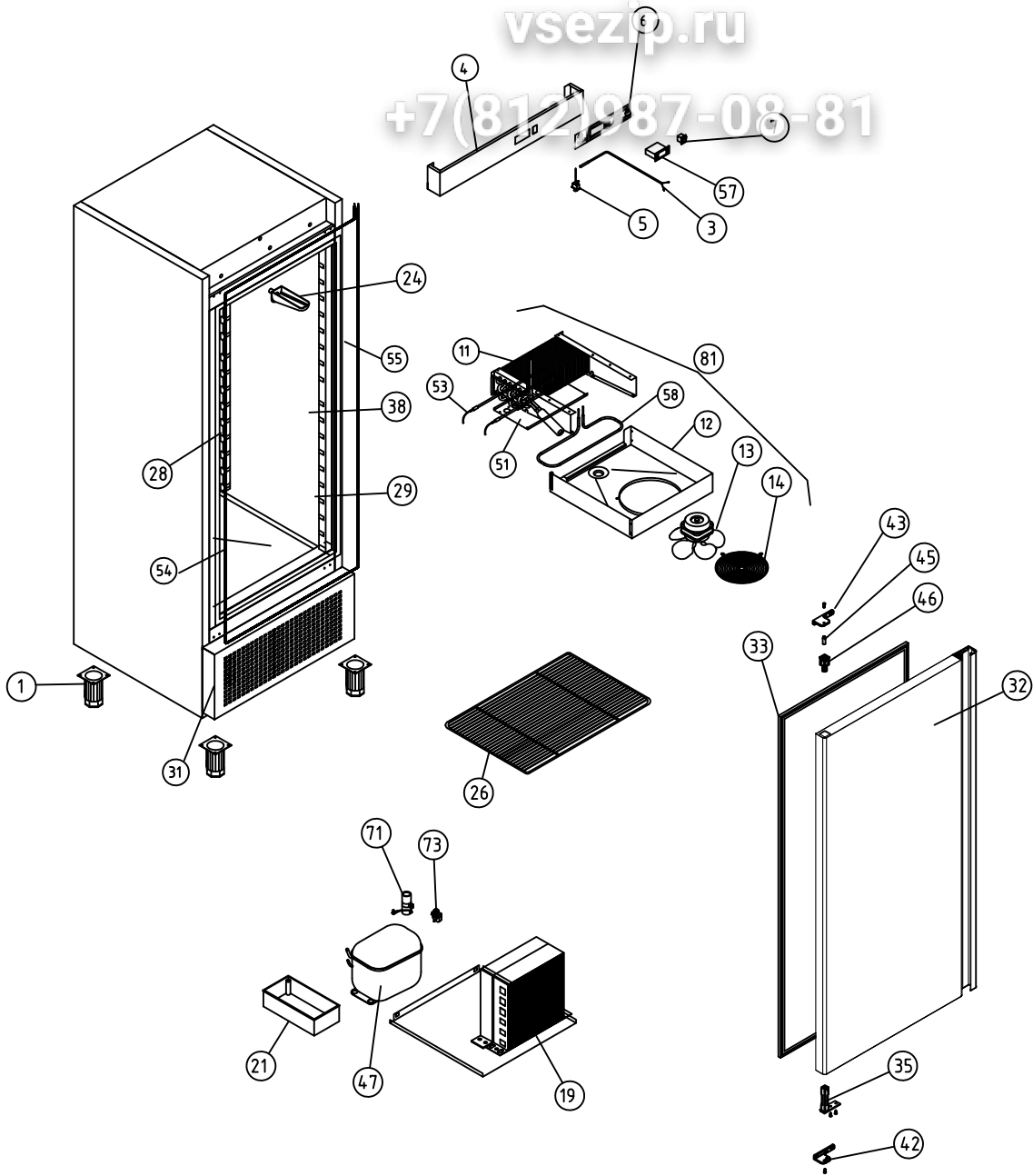

A1 ARMARIOS SNACK MANTENIMIENTO CONGELADOS

COD. PIEZA: X

COTAS SIN TOLERANCIA DIN 7168-f

Material: MATERIAL ESPESOR

SUSTITUYE A:

Acabado: ACABADO

SUSTITUIDO POR:

ANGULAR	GRADO TOLERANCIA	FINO	MEDIO	GRUESO	COMUN A	MODELO	Ud.	MODELO	Ud.	MODELO	Ud.	MODELO	Ud.	MODELO	Ud.
	HASTA 10 mm		±1°			±1° 30'	AFN-701	1							
MAS DE 10 A 50 mm		±30'		±50'											
MAS DE 50 A 120 mm		±20'		±25'											
MAS DE 120 A 400 mm		±10'		±15'											
MAS DE 400 mm		±5'		±10'											
LINEAL	GRADO TOLERANCIA	FINO	MEDIO	GRUESO	A4	Nombre	Fecha		 Fagofri, s.a.						
	HASTA 3 mm	±0,05	±0,10	±0,15											
	MAS DE 3 A 6 mm	±0,05	±0,10	±0,20	Dibujado	A.J.GONZALEZ	.21-10-10								
	MAS DE 6 A 30 mm	±0,10	±0,20	±0,50	Modificado	B. MORENO	Oct-2012								
	MAS DE 30 A 120 mm	±0,15	±0,30	±0,80	Escala										
MAS DE 120 A 400 mm	±0,20	±0,50	±1,20	1:30	RECAMBIOS AFN-701						Código máquina:				
MAS DE 400 A 1000 mm	±0,30	±0,80	±2,00								CODIGO				
MAS DE 1000 A 2000 mm	±0,50	±1,20	±3,00												

Зип Ощепит

vsezip.ru

+7(812)987-08-81

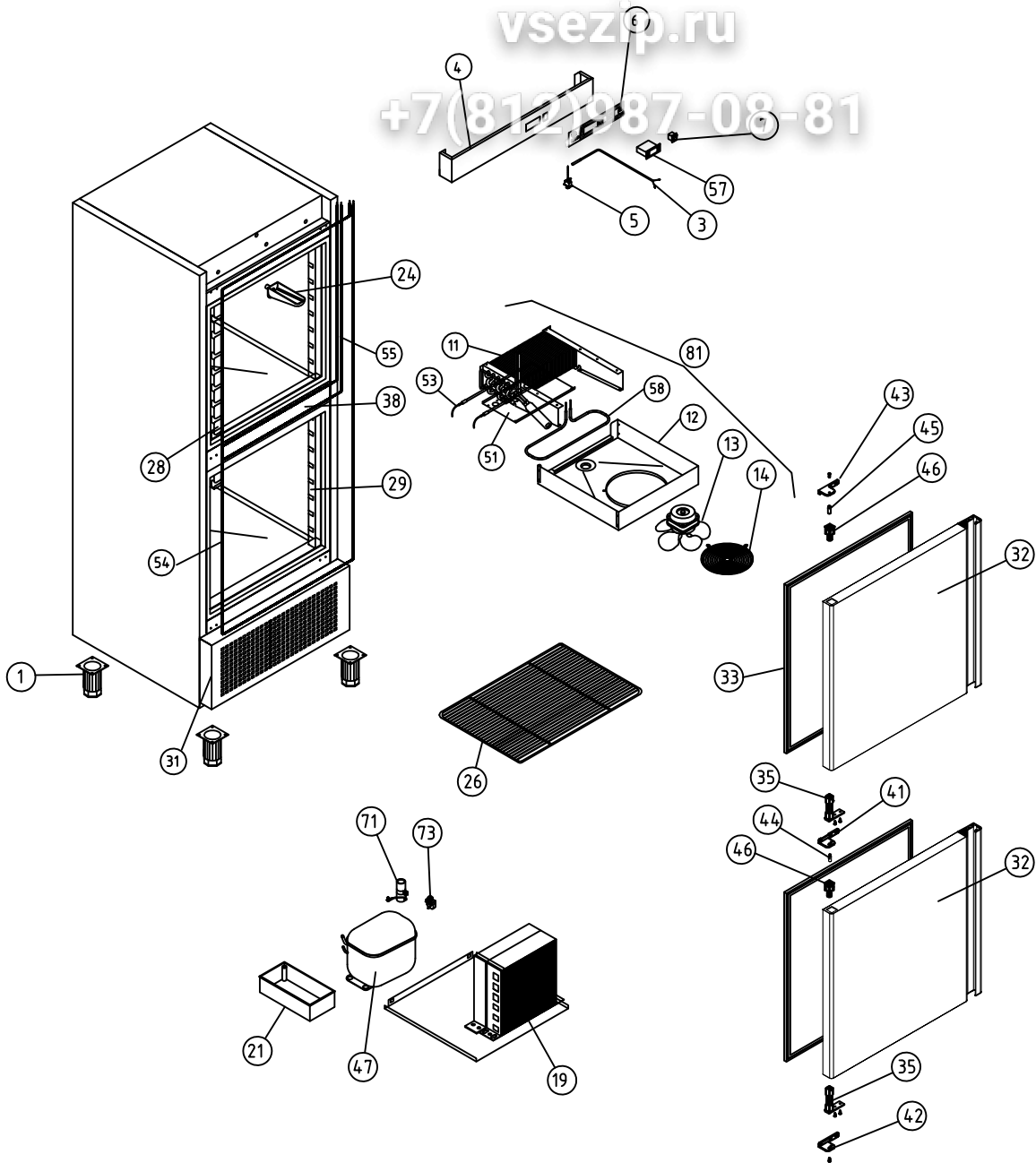

A1 ARMARIOS SNACK MANTENIMIENTO CONGELADOS

COD. PIEZA: X

COTAS SIN TOLERANCIA DIN 7168-f

Material: MATERIAL ESPESOR

SUSTITUYE A:

GRADO TOLERANCIA FINO MEDIO GRUESO

Acabado: ACABADO

SUSTITUIDO POR:

GRADO TOLERANCIA	FINO	MEDIO	GRUESO
HASTA 10 mm	±1°	±1° 30'	
MÁS DE 10 A 50 mm	±30'	±50'	
MÁS DE 50 A 120 mm	±20'	±25'	
MÁS DE 120 A 400 mm	±10'	±15'	
MÁS DE 400 mm	±5'	±10'	

COMUN A	MODELO	Ud.	MODELO	Ud.	MODELO	Ud.	MODELO	Ud.	MODELO	Ud.
		AFN-702	1							

GRADO TOLERANCIA	FINO	MEDIO	GRUESO
HASTA 3 mm	±0,05	±0,10	±0,15
MÁS DE 3 A 6 mm	±0,05	±0,10	±0,20
MÁS DE 6 A 30 mm	±0,10	±0,20	±0,50
MÁS DE 30 A 120 mm	±0,15	±0,30	±0,80
MÁS DE 120 A 400 mm	±0,20	±0,50	±1,20
MÁS DE 400 A 1000 mm	±0,30	±0,80	±2,00
MÁS DE 1000 A 2000 mm	±0,50	±1,20	±3,00

A4	Nombre	Fecha
Dibujado	A.J.GONZALEZ	.21-10-10
Modificado	B. MORENO	Oct-2012



Escala	1:30	RECAMBIOS AFN-702	Código máquina: CODIGO
--------	------	-------------------	---------------------------

Зип Общепит

vsezip.ru

+7(812)987-08-81

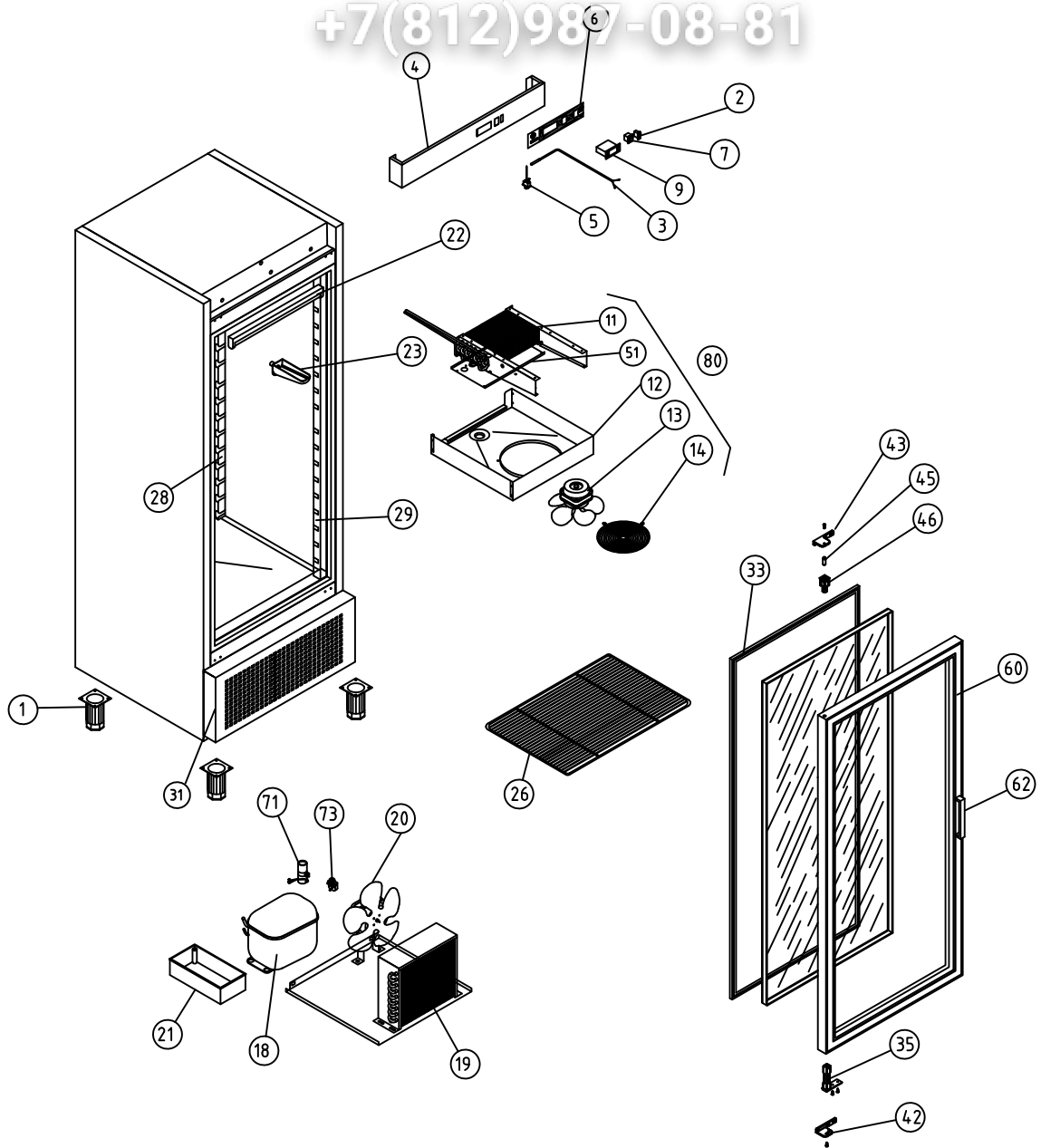

A1 ARMARIOS SNACK

COD. PIEZA: X

COTAS SIN TOLERANCIA DIN 7168-f

Material: MATERIAL ESPESOR

SUSTITUYE A:

ANGULAR	GRADO TOLERANCIA	FINO	MEDIO	GRUESO
	HASTA 10 mm		±1°	±1° 30'
	MAS DE 10 A 50 mm	±30'		±50'
	MAS DE 50 A 120 mm	±20'		±25'
	MAS DE 120 A 400 mm	±10'		±15'
MAS DE 400 mm	±5'		±10'	

Acabado: ACABADO

SUSTITUIDO POR:

ANGULAR	GRADO TOLERANCIA	FINO	MEDIO	GRUESO
	HASTA 3 mm	±0,05	±0,10	±0,15
	MAS DE 3 A 6 mm	±0,05	±0,10	±0,20
	MAS DE 6 A 30 mm	±0,10	±0,20	±0,50
	MAS DE 30 A 120 mm	±0,15	±0,30	±0,80
MAS DE 120 A 400 mm	±0,20	±0,50	±1,20	
MAS DE 400 A 1000 mm	±0,30	±0,80	±2,00	
MAS DE 1000 A 2000 mm	±0,50	±1,20	±3,00	

COMUN A	MODELO	Ud.	MODELO	Ud.	MODELO	Ud.	MODELO	Ud.	MODELO	Ud.
	AEP-701	1								

LINEAL	GRADO TOLERANCIA	FINO	MEDIO	GRUESO
	HASTA 3 mm	±0,05	±0,10	±0,15
	MAS DE 3 A 6 mm	±0,05	±0,10	±0,20
	MAS DE 6 A 30 mm	±0,10	±0,20	±0,50
	MAS DE 30 A 120 mm	±0,15	±0,30	±0,80
MAS DE 120 A 400 mm	±0,20	±0,50	±1,20	
MAS DE 400 A 1000 mm	±0,30	±0,80	±2,00	
MAS DE 1000 A 2000 mm	±0,50	±1,20	±3,00	

A4	Nombre	Fecha
Dibujado	A.J.GONZALEZ	.21-10-10
Modificado	B. MORENO	Oct-2012



Escala	1:30	RECAMBIOS AEP-701	Código máquina: CODIGO
--------	------	-------------------	---------------------------