

Зип Общепит

DESPIECE TECNICO

vsezip.ru

+7(812)987-08-81

**Armarios Frigorificos GN**  
**Armoires Réfrigérées GN**  
**GN Refrigerated Cabinets**  
**GN Hochkühlschränke**  
**Armadi frigoriferi GN**

**Modelos:**

**AFP-800**

**AF-800**

**AFN-800**

**AEP-800**

*Mayo 2003 May*



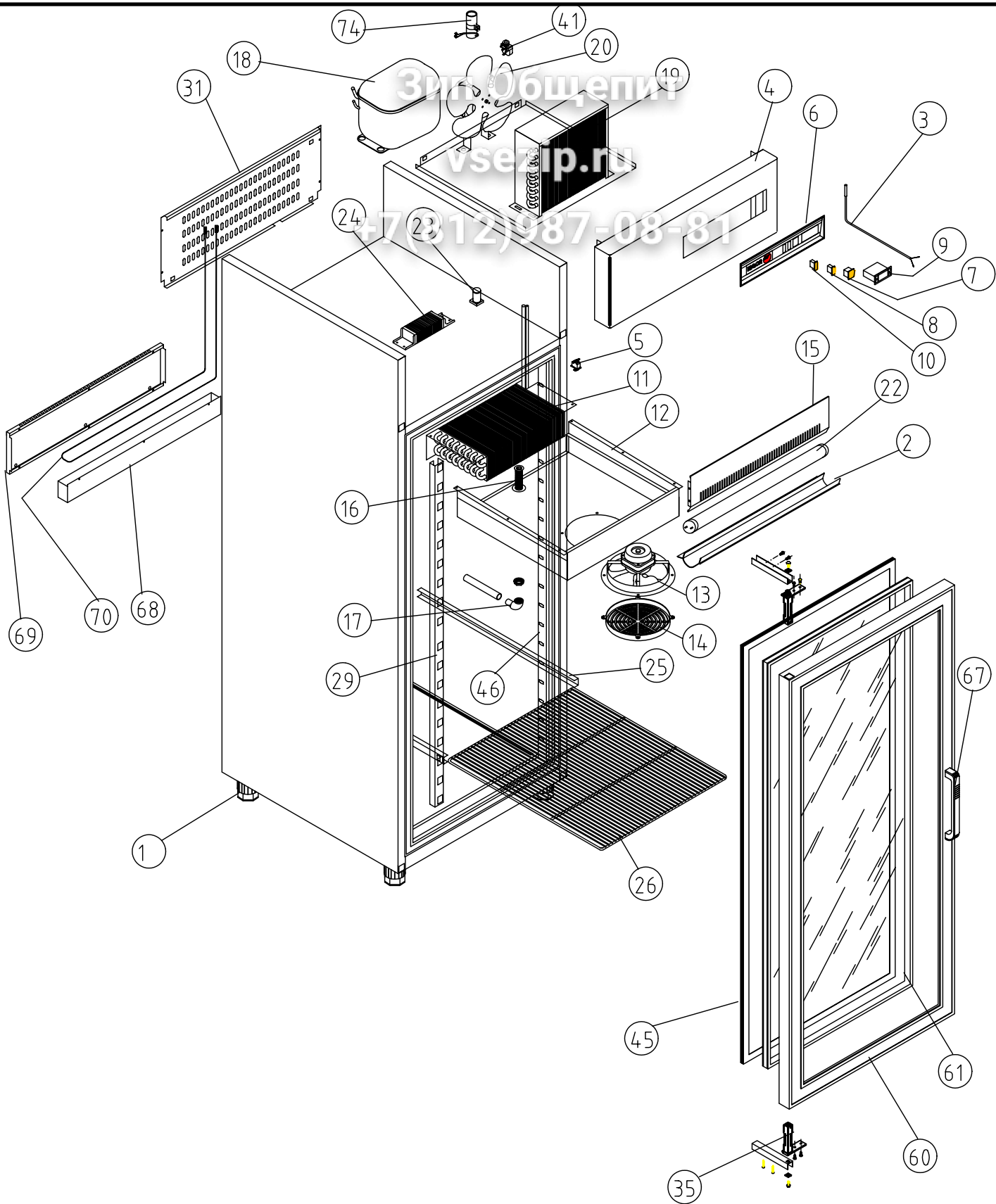

**Fagor Industrial**



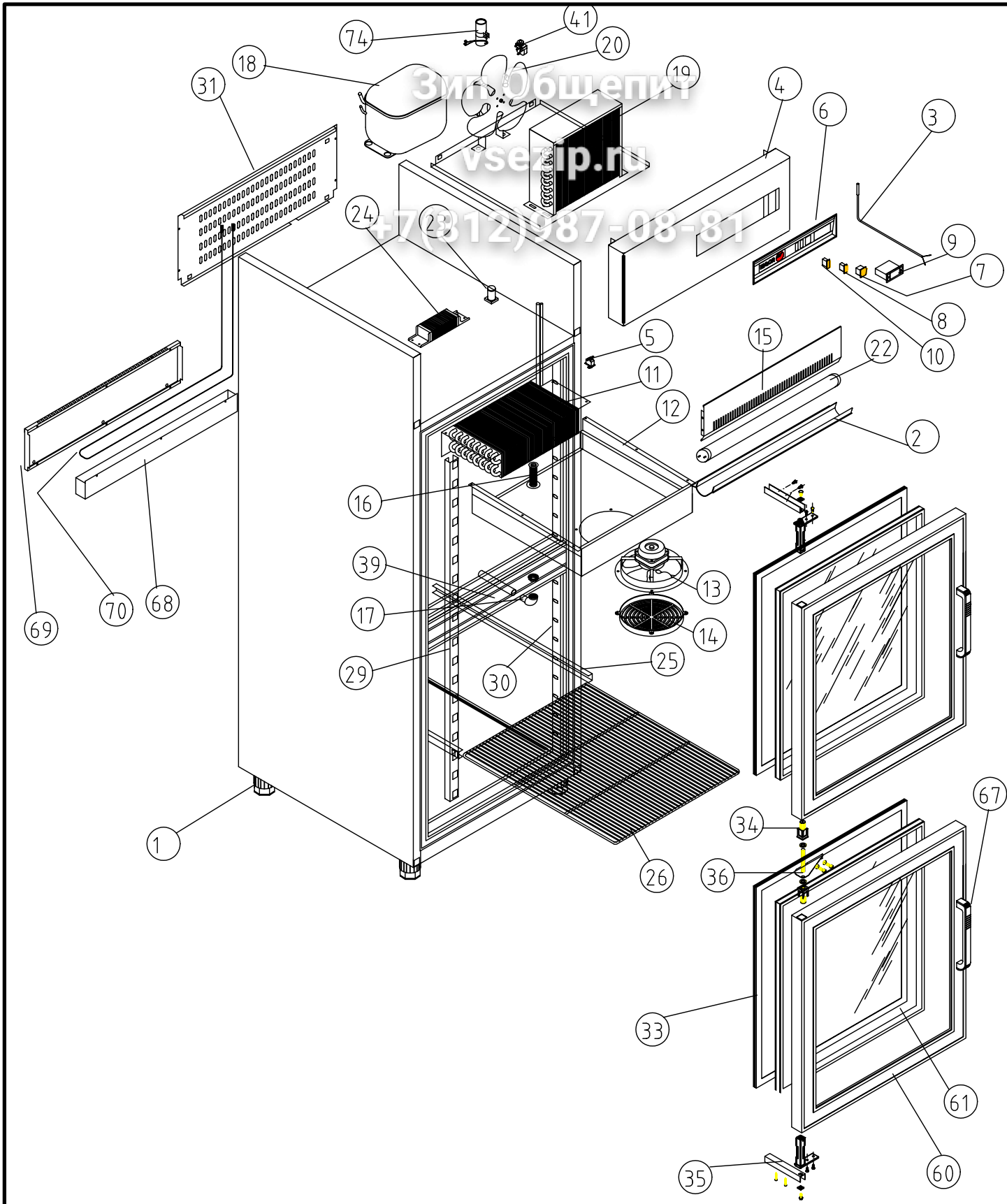

A1 ARMARIOS GASTRONORM				COD. PIEZA: X										
COTAS SIN TOLERANCIA DIN 7168-f				Material: <b>MATERIAL ESPESOR</b>										
				Acabado: <b>ACABADO</b>										
ANGULAR	GRADO TOLERANCIA	FINO	MEDIO	GRUESO	COMÚN A	MODELO	Ud.	MODELO	Ud.	MODELO	Ud.	MODELO	Ud.	MODELO
	HASTA 10 mm		±1°	±1° 30'		AEP-801	1							
	MAS DE 10 A 50 mm		±30'	±50'										
	MAS DE 50 A 120 mm		±20'	±25'										
LINEAL	MAS DE 120 A 400 mm		±10'	±15'										
	MAS DE 400 mm		±5'	±10'										
	GRADO TOLERANCIA	FINO	MEDIO	GRUESO	A4		Nombre		Fecha		 Fagofri, s.a.			
	HASTA 3 mm	±0,05	±0,10	±0,15	Dibujado		G.CH		.31-3-03					
	MAS DE 3 A 6 mm	±0,05	±0,10	±0,20	Modificado									
	MAS DE 6 A 30 mm	±0,10	±0,20	±0,50	Escala		1:20							
MAS DE 30 A 120 mm	±0,15	±0,30	±0,80							Código máquina:				
MAS DE 120 A 400 mm	±0,20	±0,50	±1,20							CODIGO				
MAS DE 400 A 1000 mm	±0,30	±0,80	±2,00											
MAS DE 1000 A 2000 mm	±0,50	±1,20	±3,00											

RECAMBIOS AEP-801

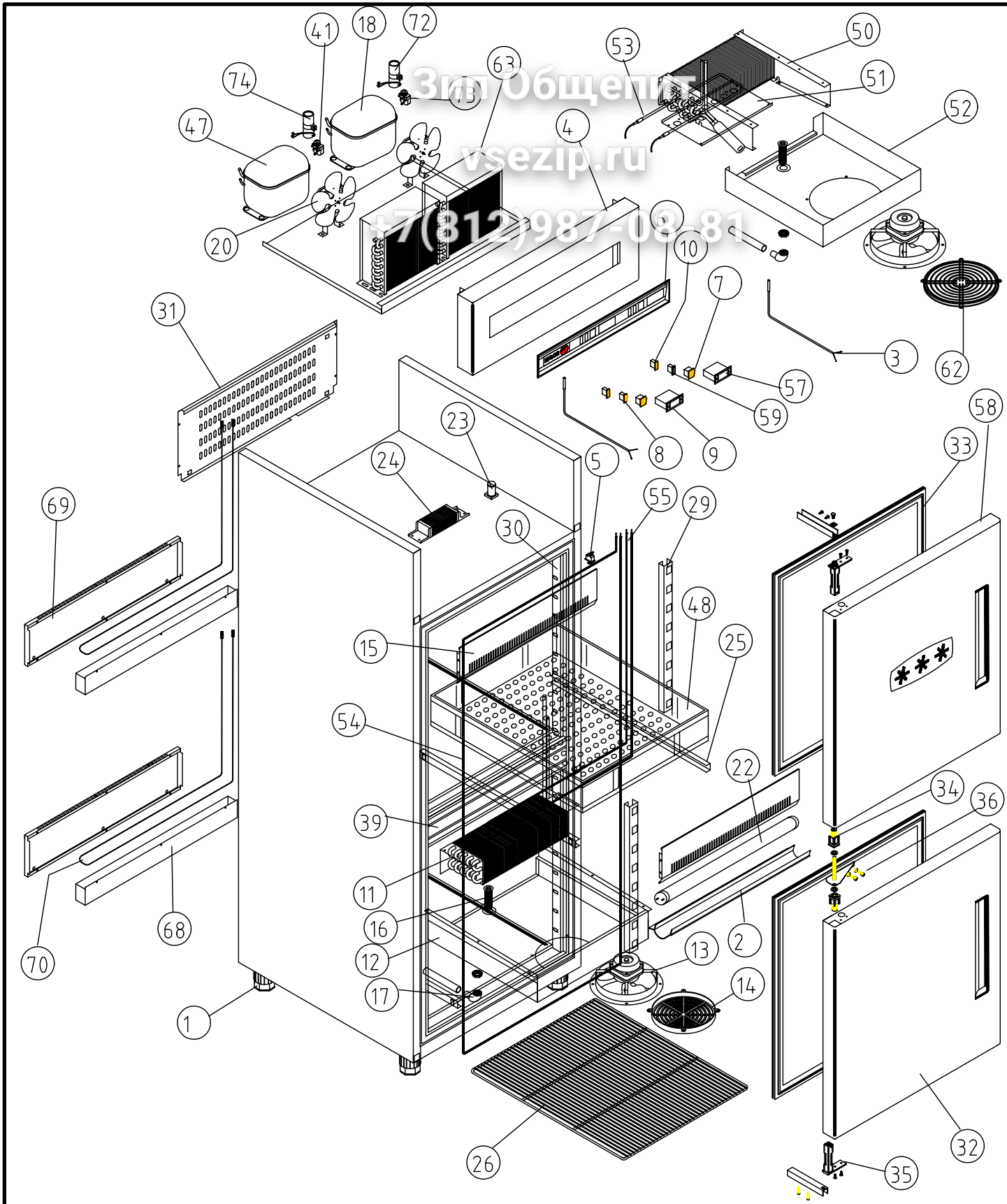

A1 ARMARIOS GASTRONORM				COD. PIEZA: X					
COTAS SIN TOLERANCIA DIN 7168-f				Material: <b>MATERIAL ESPESOR</b>					
				Acabado: <b>ACABADO</b>					
ANGULAR	GRADO TOLERANCIA	FINO	MEDIO	GRUESO					
	HASTA 10 mm		±1°	±1° 30'					
	MAS DE 10 A 50 mm		±30'	±50'					
	MAS DE 50 A 120 mm		±20'	±25'					
	MAS DE 120 A 400 mm		±10'	±15'					
			±5'	±10'					
LINEAL	GRADO TOLERANCIA	FINO	MEDIO	GRUESO					
	HASTA 3 mm		±0,05	±0,10	±0,15				
	MAS DE 3 A 6 mm		±0,05	±0,10	±0,20				
	MAS DE 6 A 30 mm		±0,10	±0,20	±0,50				
	MAS DE 30 A 120 mm		±0,15	±0,30	±0,80				
			±0,20	±0,50	±1,20				
			±0,30	±0,80	±2,00				
			±0,50	±1,20	±3,00				
Material: <b>MATERIAL ESPESOR</b>		Acabado: <b>ACABADO</b>		SUSTITUYE A:		SUSTITUIDO POR:			
COMÚN A	MODELO	Ud.	MODELO	Ud.	MODELO	Ud.	MODELO		
	AEP-802	1							
A4		Nombre		Fecha		 <b>FAGOR</b> Fagofri, s.a.			
Dibujado		G.CH		.31-3-03					
Modificado									
Escala		1:20		RECAMBIOS AEP-802		Código máquina: CODIGO			



A1 ARMARIOS GASTRONORM DEPARTAMENTO MANTENIMIENTO CONGELADOS				COD. PIEZA: X												
COTAS SIN TOLERANCIA DIN 7168-f				Material: <b>MATERIAL ESPESOR</b>												
				Acabado: <b>ACABADO</b>												
ANGULAR	GRADO TOLERANCIA	FINO	MEDIO	GRUESO	COMÚN A	MODELO	Ud.	MODELO	Ud.	MODELO	Ud.	MODELO	Ud.	MODELO	Ud.	
	HASTA 10 mm		±1°	±1° 30'		AF-802-C	1									
	MÁS DE 10 A 50 mm		±30'	±50'												
	MÁS DE 50 A 120 mm		±20'	±25'												
	MÁS DE 120 A 400 mm		±10'	±15'												
	MÁS DE 400 mm		±5'	±10'												
LINEAL	GRADO TOLERANCIA	FINO	MEDIO	GRUESO	A4		Nombre		Fecha		 <b>FAGOR</b> Fagofri, s.a.		Código máquina: <b>CODIGO</b>			
	HASTA 3 mm		±0,05	±0,10	±0,15	Dibujado		G.CH		.31-3-03						
	MÁS DE 3 A 6 mm		±0,05	±0,10	±0,20	Modificado										
	MÁS DE 6 A 30 mm		±0,10	±0,20	±0,50	Escala		1:20		RECAMBIOS AF-802-C						
	MÁS DE 30 A 120 mm		±0,15	±0,30	±0,80											
	MÁS DE 120 A 400 mm		±0,20	±0,50	±1,20											
	MÁS DE 400 A 1000 mm		±0,30	±0,80	±2,00											
MÁS DE 1000 A 2000 mm		±0,50	±1,20	±3,00												

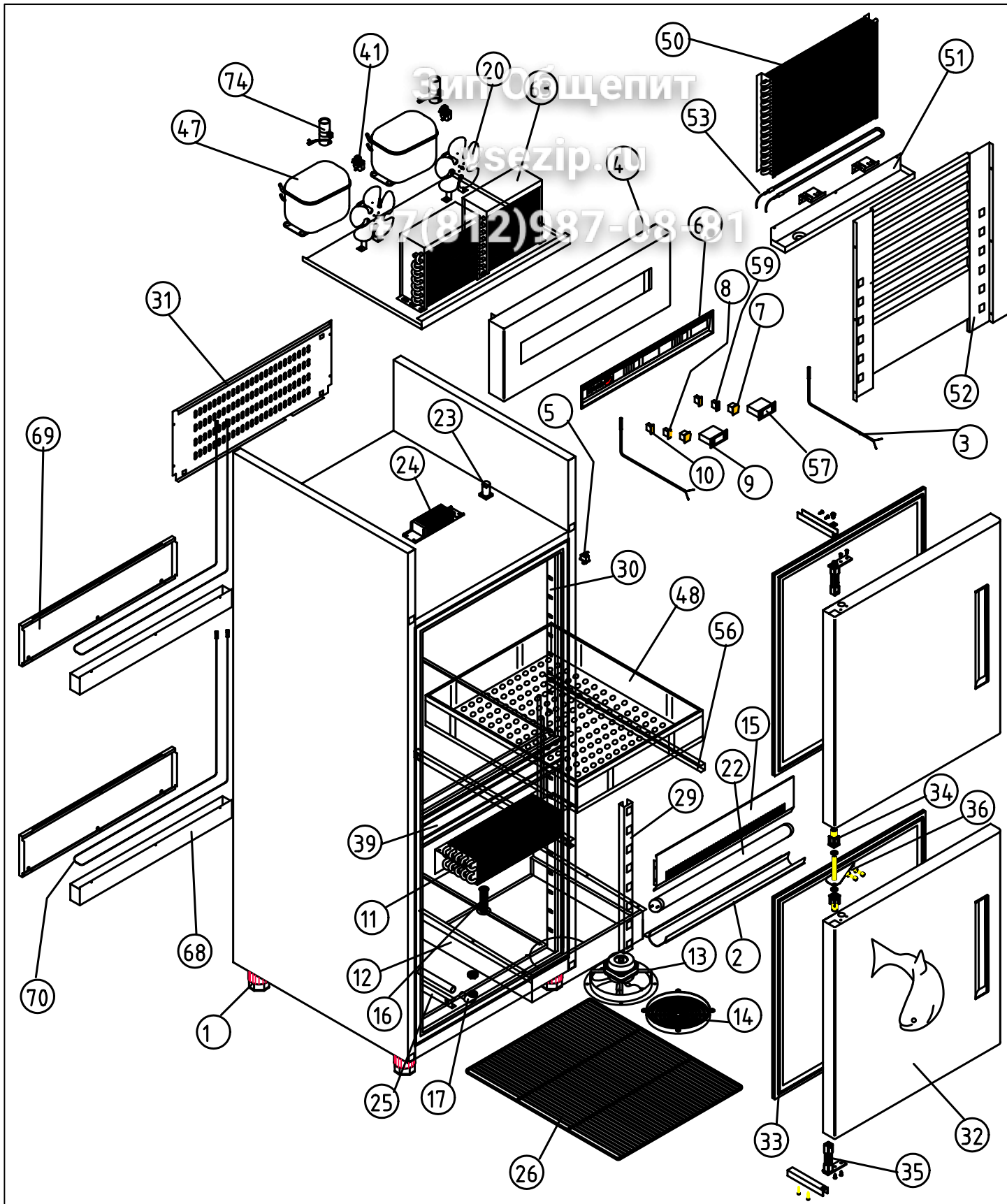

A1 ARMARIOS GASTRONORM DEPARTAMENTO DE PESCADO				COD. PIEZA: X											
COTAS SIN TOLERANCIA DIN 7168-f				Material: MATERIAL ESPESOR											
				Acabado: ACABADO											
ANGULAR	GRADO TOLERANCIA	FINO	MEDIO	GRUESO	COMÚN A	MODELO	Ud.	MODELO	Ud.	MODELO	Ud.	MODELO	Ud.	MODELO	Ud.
	HASTA 10 mm		±1°	±1° 30'		AF-802-P	1								
	MAS DE 10 A 50 mm		±30'	±50'											
	MAS DE 50 A 120 mm		±20'	±25'											
	MAS DE 120 A 400 mm		±10'	±15'											
	MAS DE 400 mm		±5'	±10'											
LINEAL	GRADO TOLERANCIA	FINO	MEDIO	GRUESO	A4	Nombre		Fecha		 <b>FAGOR</b> Fagofri, s.a.		Código máquina: CODIGO			
	HASTA 3 mm	±0,05	±0,10	±0,15	Dibujado	G.CH		.31-3-03							
	MAS DE 3 A 6 mm	±0,05	±0,10	±0,20	Modificado										
	MAS DE 6 A 30 mm	±0,10	±0,20	±0,50	Escala					RECAMBIOS AF-802-P					
	MAS DE 30 A 120 mm	±0,15	±0,30	±0,80											
	MAS DE 120 A 400 mm	±0,20	±0,50	±1,20											
	MAS DE 400 A 1000 mm	±0,30	±0,80	±2,00											
MAS DE 1000 A 2000 mm	±0,50	±1,20	±3,00	1:20											

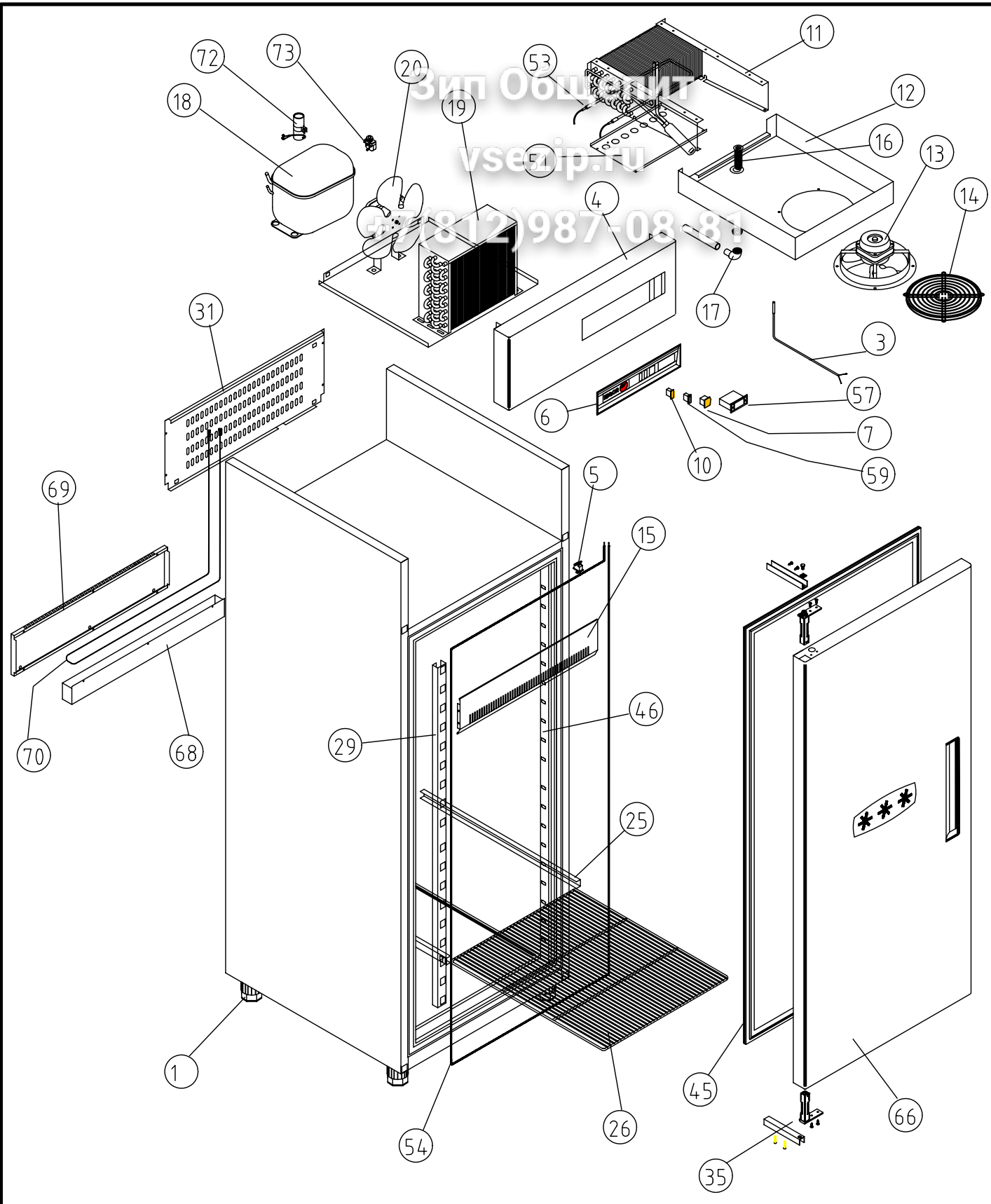

A1 ARMARIOS GASTRONORM MANTENIMIENTO DE CONGELADOS				COD. PIEZA: X					
COTAS SIN TOLERANCIA DIN 7168-f				Material: <b>MATERIAL ESPESOR</b>					
				Acabado: <b>ACABADO</b>					
ANGULAR	GRADO TOLERANCIA	FINO	MEDIO	GRUESO	SUSTITUYE A:				
	HASTA 10 mm	±1°		±1° 30'	SUSTITUIDO POR:				
	MAS DE 10 A 50 mm	±30'		±50'	MODELO	Ud.	MODELO	Ud.	
	MAS DE 50 A 120 mm	±20'		±25'	AFN-801	1			
MAS DE 120 A 400 mm	±10'		±15'						
MAS DE 400 mm	±5'		±10'						
LINEAL	GRADO TOLERANCIA	FINO	MEDIO	GRUESO	Nombre			Fecha	
	HASTA 3 mm	±0,05	±0,10	±0,15	A4			.31-3-03	
	MAS DE 3 A 6 mm	±0,05	±0,10	±0,20	Dibujado G.CH				
	MAS DE 6 A 30 mm	±0,10	±0,20	±0,50	Modificado				
	MAS DE 30 A 120 mm	±0,15	±0,30	±0,80	Escala				
	MAS DE 120 A 400 mm	±0,20	±0,50	±1,20	1:20				
MAS DE 400 A 1000 mm	±0,30	±0,80	±2,00						
MAS DE 1000 A 2000 mm	±0,50	±1,20	±3,00						
				<b>RECAMBIOS AFN-801</b>				Código máquina: <b>CODIGO</b>	
				<b>FAGOR</b>					
				Fagofri, s.a.					

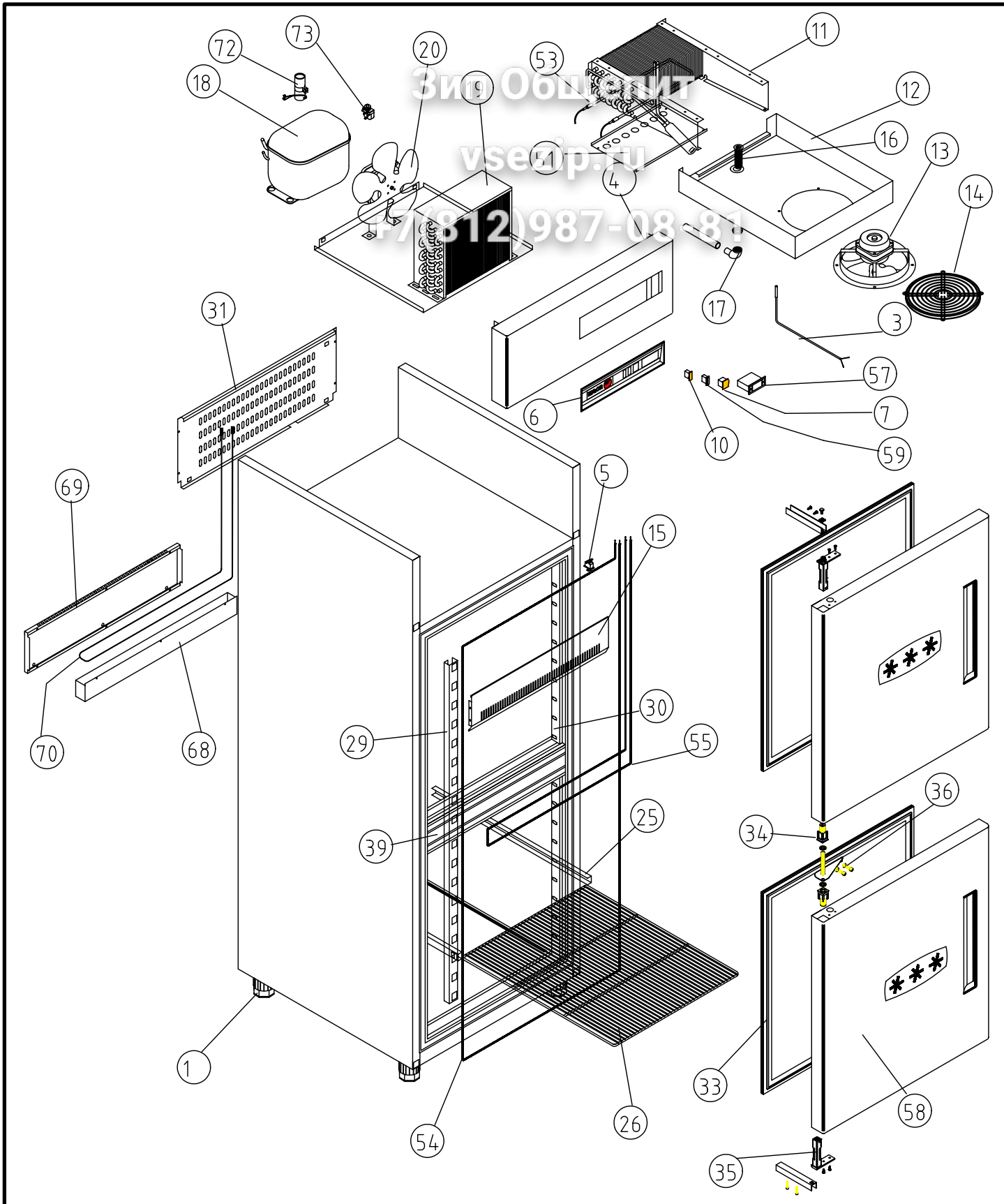

A1 ARMARIOS GASTRONORM MANTENIMIENTO DE CONGELADOS				COD. PIEZA: X					
COTAS SIN TOLERANCIA DIN 7168-f				Material: <b>MATERIAL ESPESOR</b>					
				Acabado: <b>ACABADO</b>					
ANGULAR	GRADO TOLERANCIA	FINO	MEDIO	GRUESO	COMÚN A			SUSTITUYE A:	
	HASTA 10 mm	±1°		±1° 30'	MODELO	Ud.	MODELO	Ud.	MODELO
	MÁS DE 10 A 50 mm	±30'		±50'	AFN-802	1			
	MÁS DE 50 A 120 mm	±20'		±25'					
LINEAL	MÁS DE 120 A 400 mm	±10'		±15'	Nombre			Fecha	
	MÁS DE 400 mm	±5'		±10'	Dibujado			.31-3-03	
					Modificado				
	GRADO TOLERANCIA	FINO	MEDIO	GRUESO	Escala			Código máquina:	
	HASTA 3 mm	±0,05	±0,10	±0,15	1:20			RECAMBIOS AFN-802	
	MÁS DE 3 A 6 mm	±0,05	±0,10	±0,20				CODIGO	
MÁS DE 6 A 30 mm	±0,10	±0,20	±0,50						
MÁS DE 30 A 120 mm	±0,15	±0,30	±0,80						
MÁS DE 120 A 400 mm	±0,20	±0,50	±1,20						
MÁS DE 400 A 1000 mm	±0,30	±0,80	±2,00						
MÁS DE 1000 A 2000 mm	±0,50	±1,20	±3,00						



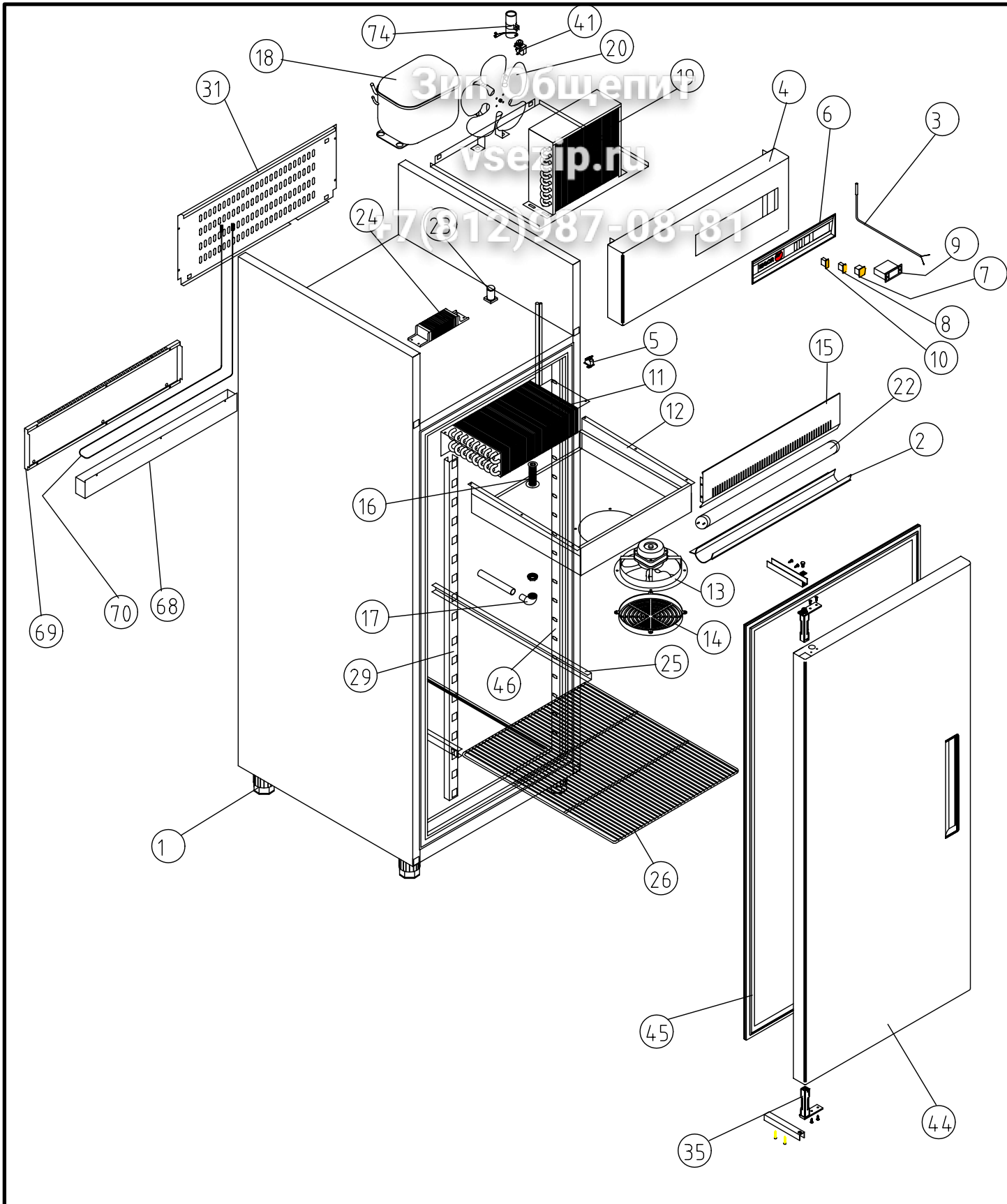

A1 ARMARIOS GASTRONORM				COD. PIEZA: X						
COTAS SIN TOLERANCIA DIN 7168-f				Material: <b>MATERIAL ESPESOR</b>						
				Acabado: <b>ACABADO</b>						
ANGULAR	GRADO TOLERANCIA	FINO	MEDIO	GRUESO	SUSTITUYE A:					
	HASTA 10 mm		±1°	±1° 30'	SUSTITUIDO POR:					
	MAS DE 10 A 50 mm		±30'	±50'	MODELO	Ud.	MODELO	Ud.		
	MAS DE 50 A 120 mm		±20'	±25'	AFP-801	1				
MAS DE 120 A 400 mm		±10'	±15'							
MAS DE 400 mm		±5'	±10'							
LINEAL	GRADO TOLERANCIA	FINO	MEDIO	GRUESO	Nombre			Fecha		
	HASTA 3 mm		±0,05	±0,10	±0,15	A4			.31-3-03	
	MAS DE 3 A 6 mm		±0,05	±0,10	±0,20	Dibujado G.CH				
	MAS DE 6 A 30 mm		±0,10	±0,20	±0,50	Modificado				
	MAS DE 30 A 120 mm		±0,15	±0,30	±0,80	Escala				
	MAS DE 120 A 400 mm		±0,20	±0,50	±1,20	1:20			RECAMBIOS AFP-801	
	MAS DE 400 A 1000 mm		±0,30	±0,80	±2,00				Código máquina:	
MAS DE 1000 A 2000 mm		±0,50	±1,20	±3,00				CODIGO		





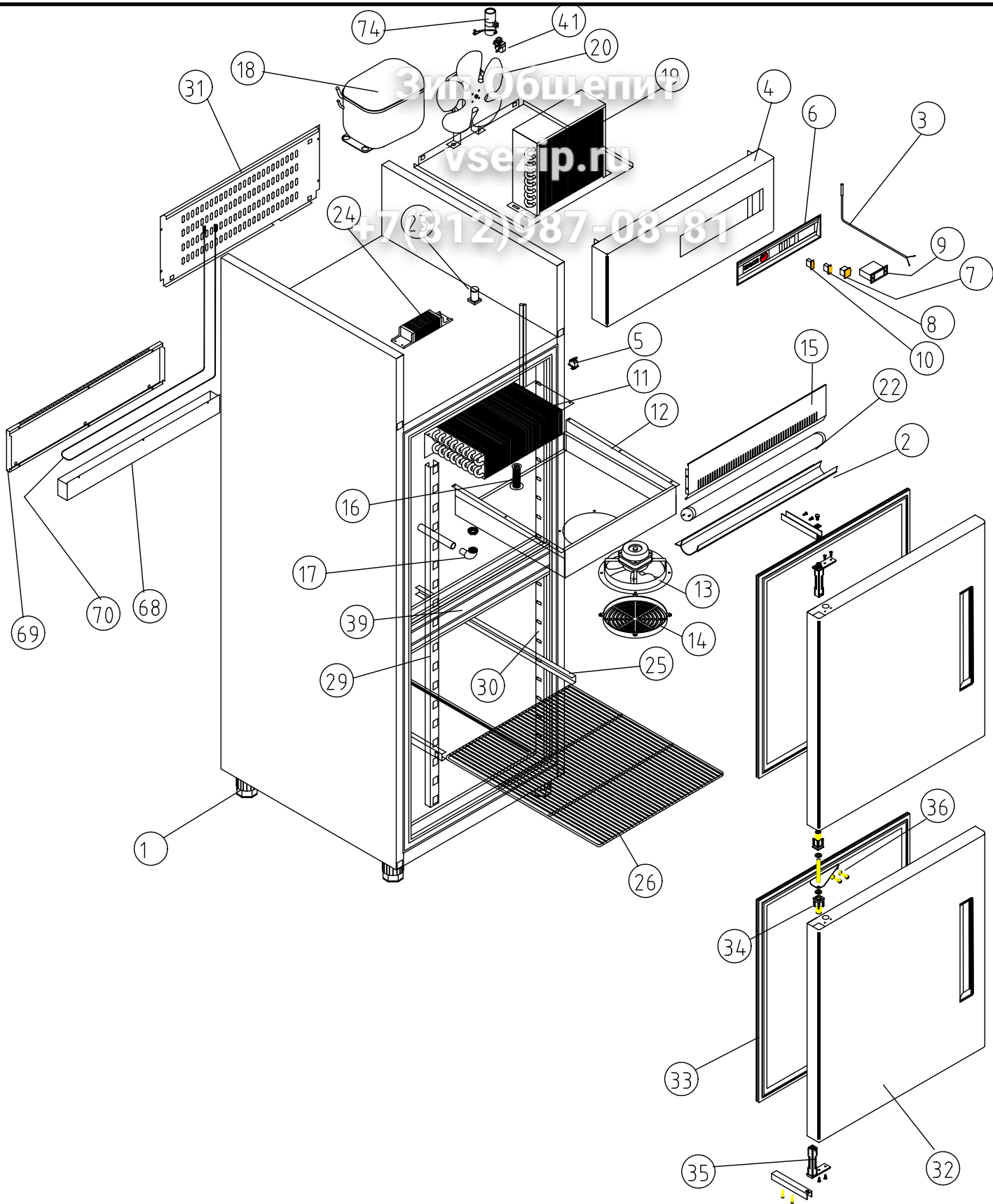

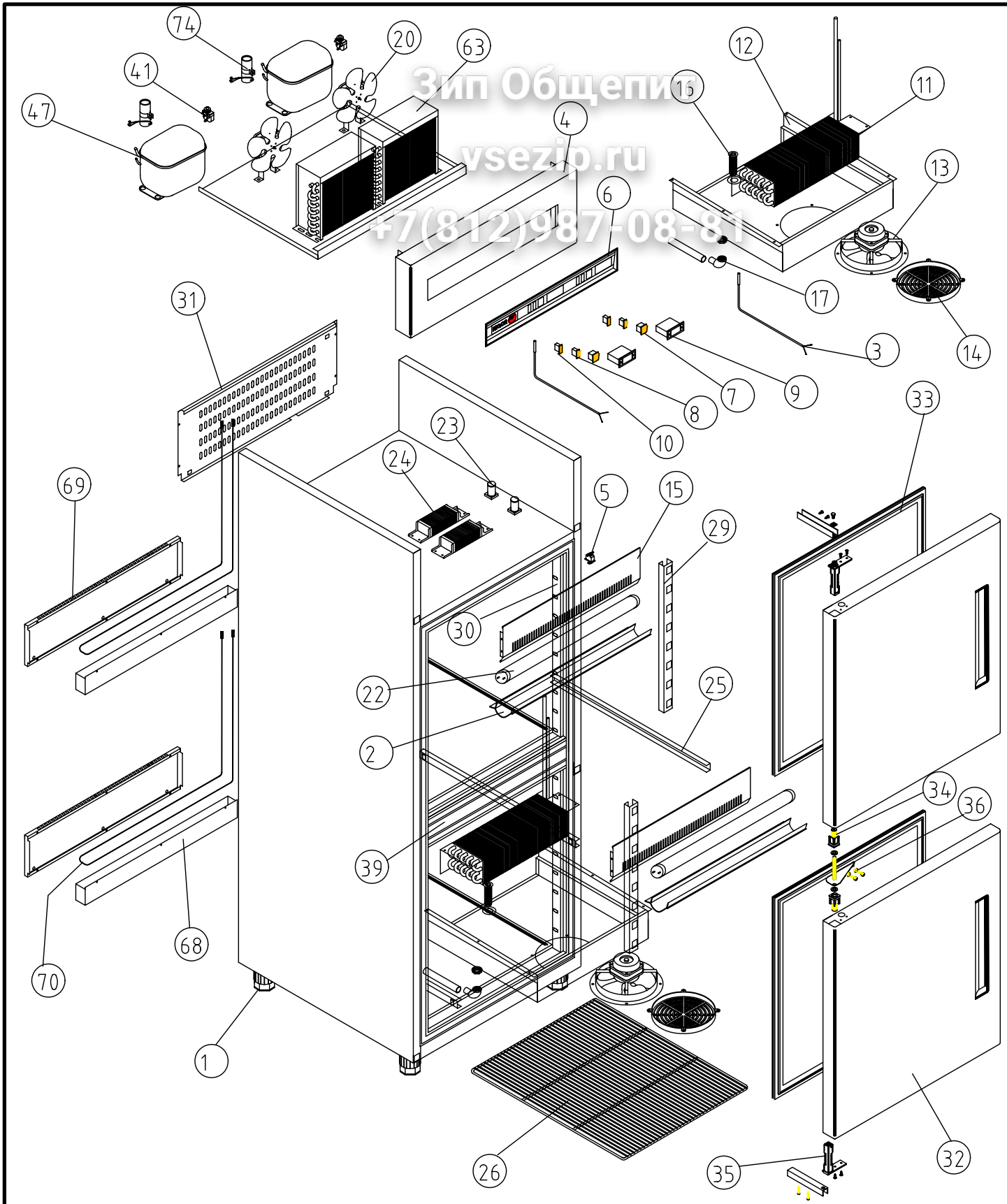

A1 ARMARIOS GASTRONORM				COD. PIEZA: X																											
COTAS SIN TOLERANCIA DIN 7168-f				Material: <b>MATERIAL ESPESOR</b>																											
<table border="1"> <thead> <tr> <th>GRADO TOLERANCIA</th> <th>FINO</th> <th>MEDIO</th> <th>GRUESO</th> </tr> </thead> <tbody> <tr> <td>HASTA 10 mm</td> <td>±1°</td> <td></td> <td>±1° 30'</td> </tr> <tr> <td>MAS DE 10 A 50 mm</td> <td>±30'</td> <td></td> <td>±50'</td> </tr> <tr> <td>MAS DE 50 A 120 mm</td> <td>±20'</td> <td></td> <td>±25'</td> </tr> <tr> <td>MAS DE 120 A 400 mm</td> <td>±10'</td> <td></td> <td>±15'</td> </tr> <tr> <td>MAS DE 400 mm</td> <td>±5'</td> <td></td> <td>±10'</td> </tr> </tbody> </table>				GRADO TOLERANCIA	FINO	MEDIO	GRUESO	HASTA 10 mm	±1°		±1° 30'	MAS DE 10 A 50 mm	±30'		±50'	MAS DE 50 A 120 mm	±20'		±25'	MAS DE 120 A 400 mm	±10'		±15'	MAS DE 400 mm	±5'		±10'	Acabado: <b>ACABADO</b>			
GRADO TOLERANCIA	FINO	MEDIO	GRUESO																												
HASTA 10 mm	±1°		±1° 30'																												
MAS DE 10 A 50 mm	±30'		±50'																												
MAS DE 50 A 120 mm	±20'		±25'																												
MAS DE 120 A 400 mm	±10'		±15'																												
MAS DE 400 mm	±5'		±10'																												
ANGULAR	COMUN A		MODELO	Ud.	MODELO	Ud.	MODELO	Ud.	MODELO	Ud.																					
			AFP-802	1																											
LINEAL	GRADO TOLERANCIA	FINO	MEDIO	GRUESO	A4		Nombre		Fecha																						
	HASTA 3 mm	±0,05	±0,10	±0,15	Dibujado		G.CH		.31-3-03																						
	MAS DE 3 A 6 mm	±0,05	±0,10	±0,20	Modificado																										
	MAS DE 6 A 30 mm	±0,10	±0,20	±0,50	Escala		1:20		<b>FAGOR</b> Fagofri, s.a.																						
	MAS DE 30 A 120 mm	±0,15	±0,30	±0,80																											
	MAS DE 120 A 400 mm	±0,20	±0,50	±1,20																											
	MAS DE 400 A 1000 mm	±0,30	±0,80	±2,00																											
MAS DE 1000 A 2000 mm	±0,50	±1,20	±3,00					Código máquina: <b>CODIGO</b>																							

RECAMBIOS AFP-802



A1 ARMARIOS GASTRONORM DEPARTAMENTO MANTENIMIENTO CONGELADOS				COD. PIEZA: X												
COTAS SIN TOLERANCIA DIN 7168-f				Material: <b>MATERIAL ESPESOR</b>												
				Acabado: <b>ACABADO</b>												
ANGULAR	GRADO TOLERANCIA	FINO	MEDIO	GRUESO	COMÚN A	MODELO	Ud.	MODELO	Ud.	MODELO	Ud.	MODELO	Ud.	MODELO	Ud.	
	HASTA 10 mm		±1'	±1' 30'		AF-802-C	1									
	MAS DE 10 A 50 mm		±30'	±50'												
	MAS DE 50 A 120 mm		±20'	±25'												
LINEAL	MAS DE 120 A 400 mm		±10'	±15'												
	MAS DE 400 mm		±5'	±10'												
	GRADO TOLERANCIA	FINO	MEDIO	GRUESO	A4	Nombre		Fecha		 <b>FAGOR</b> Fagofri, s.a.		Código máquina:				
	HASTA 3 mm	±0,05	±0,10	±0,15	Dibujado	G.CH		.31-3-03								
	MAS DE 3 A 6 mm	±0,05	±0,10	±0,20	Modificado	MJGG		7-4-03								
	MAS DE 6 A 30 mm	±0,10	±0,20	±0,50	Escala	1:20		RECAMBIOS AFP-802/2		CODIGO						
MAS DE 30 A 120 mm	±0,15	±0,30	±0,80													
MAS DE 120 A 400 mm	±0,20	±0,50	±1,20													
MAS DE 400 A 1000 mm	±0,30	±0,80	±2,00													
MAS DE 1000 A 2000 mm	±0,50	±1,20	±3,00													

**RECAMBIOS  
ARMARIOS**

revisión 01-03-2003



Зип Общепит

MODELOS

Nº	CÓDIGO	DESCRIPCIÓN	MODELOS										
			AFP-801	AFP-802	AFP-802/2	AFP-802-F	AFP-802-C	AFN-801	AFN-802	AFP-801	AFP-802		
1	6007050017	PATA REGULABLE ARM.GASTRO	4	4	4	4	4	4	4	4	4	4	4
2	6007170105	PERFIL POLICARBONATO 538 MM	1	1	2	1	1					1	1
3	6021350013	SONDA TERMOST.REF NTC 15KOhm	1	1	2	2	2	1	1	1	1	1	1
4	A109010134	CABEZA AFP-800 DPTO R7			1		1	1					
4	A109010133	CABEZA AFP-800 R-7								1	1	1	1
5	6021130008	MICRORRUPTOR RECTANGULAR LUCE.	1	1	1	1	1	1	1	1	1	1	1
6	6003010105	CUADRO ABS GRIS	1	1					1	1	1	1	1
6	A103010001	CUADRO ABS GRIS UNIDO			1	1	1						
7	6021130001	INTERRUPTOR BIPOLAR AMB. ON/OFF	1	1	2	2	2	1	1	1	1	1	1
8	6021130002	INTERRUPTOR UNIPOL.LUMINOS. AMB.	1	1	2	1	1					1	1
9	6021350015	TERMOSTATO TERM. REFRIG. ID 961F	1	1	2	1	1					1	1
10	6021130010	PILOTO RECTANG.AMBAR SEÑAL LUMIN.	1	1	2	2	2	1	1	1	1	1	1
11	6029010038	BAT.FC71B ARM 7T5R300A6S(PINTA							1	1			
11	6029010040	BAT.AFP-800 B8T4R330A4S(PINTADO)	1	1	2		1					1	1
11	6029010042	BAT.AFP700 5T4R330A4S(PINTADO)				1							
12	A109050184	CAJA SUJ.VENT.AFN-800							1	1			
12	A109050052	SUJECC. VENTILADOR 800	1	1	2		1					1	1
12	A109050096	SUJECC. VENTILADOR 700				1							
13	6021050013	VENTILADOR 10W 71B ARMARIOS							1	1			
13	6021050001	VENTIL.EVAP.5W ARO/TIRO FORZAD.	1	1	2	1	1					1	1
14	6027130002	REJILLA VENT.D.300 PINT Y ZINC							1	1			
14	6003010035	REJILLA PROTECCIÓN VENTILADOR	1	1	2	1	1					1	1
15	A109050049	EMBELLECEDOR FRONT. INT.	1	1	2	1	2	1	1	1	1	1	1
16	6003010033	DESAGÜE 1/2 PULG.CUELLO CORTO	1	1	2	1	2	1	1	1	1	1	1
17	6003010175	CODO PVC MIXTO 90° 20X1/2	1	1	2	1	2	1	1	1	1	1	1
18	6021010001	COMPR.SC-12-CL R404A						1					
18	6021010002	COMPR.SC-15-CL R404A							1	1			
18	6021010007	COMPRES.FR-8.5-G R134A	1	1								1	1
19	6029020005	CONDENSADOR 10x4 TECHO							1	1			
19	6029020002	CONDENSADOR 9X2	1	1								1	1
20	6021050002	VENTILADOR 10W PATA PALA 220V	1	1	2	2	2	1	1	1	1	1	1
22	6021290001	TUBO FLUORESCENTE DE 15W	1	1	2	1	1					1	1
23	6021290009	CEBADOR 1-22W 220V	1	1	2	1	1					1	1
24	6021290014	REACTANCIA 40W 220V	1	1	2	1	1					1	1
25	6033050016	GUIA GN L=662 MM	6	6	4	2	8	6	6	6	6	6	6
26	6027010009	PARRILLA GN 2/1 650X530	3	3	2	1	1	3	3	3	3	3	3
29	A109050072	CREMALL. RESP. DTO.			4	4	4						
29	A109050071	CREMALL.RESPALDO AFP-GN	2	2				2	2	2	2	2	2
30	A109050069	CREMALL.MARCO PUERTA PEQ.		4	4	4	4		4			4	
31	A179050004	REJILLA MOTOR 800	1	1	1	1	1	1	1	1	1	1	1
32	A169010011	PUERTA PEQ.AFP 702/802 TIR.ABS		2	2	2	1						
33	6045010013	BURLETE 636X736 ARM. PUERTA PEQ		2	2	2	2		2			2	
34	6003010136	CAJA ALOJAM.MUELLE GRIS		2	2	2	2	2	2	2	2	2	2
35	6033010003	BISAGRA TRS1D DOBLE MUELLE	2	2	2	2	2	2	2	2	2	2	2
36	A169090002	BISAGRA PUERT.PEQ.CRIST.IZDA											1
36	A169090001	BISAGRA PUERTA PEQ.AFP IZDA		1	1	1	1	1		1			
39	A161130004	FRONTI HORIZ POST IZDA(RESIST						1		1			
39	A161130002	FRONTI HORIZ.POSTIZO IZDA		1	1	1							1
41	6021010025	RELE ARRANQ. COMPR.FR-8.5G 220V	1	1								1	1
41	6021010044	RELE ARRANQ COMPRES. TL-5 G 6000			2	2	1						
44	A169010009	PUERTA CARN AFP700/800 TIR ABS	1	1									
45	6045010030	BURLETE 636x1520 MM ARMAR.CARNI	1					1				1	
46	A109050070	CREMALL. MARCO PUERTA CARNI	2					2		2			
47	6021010003	COMPR.TL-5-G R134A			2	2	1						
48	6003050006	CUBETA DPTO CONGEL.530X540					3	3					
50	6029010041	EV.DPTO.PESC B14T2R426A6S(PINT					1						
50	6029010036	BAT.FC61B ARM 6T4R300A6S(PINTA						1					
51	A109050048	BANDEJA GOTE0 800-P					1						
51	A109050181	CUBRERRESIST.EVAP FC-61B-ARMAR						1					
51	A109050206	CUBRERRESIST.EVAP.AFN-800							1	1			
52	A109050067	SOP. DUELAS 800-P					1						
52	A109050180	CAJA SUJ.VENT.AP-APP-AFN-700						1					
53	6021250051	RESIST.DESES.DEP.PESC.220V425W				1							
53	6021250019	RESIST.BLIND.FC61-71 350W 1000						1	1	1			
54	6021250009	RESIST.MARCO EXT.700/800 43W						1	1	1			
55	6021250008	RESIST.FRONTI H.1400-1600 12W						1		1			
56	6033050012	GUIA BAJ GN CENT L=613MM Y PES				6							
57	6021350019	TERMOS.CONGELAC.ID 974 F 220V					1	1	1	1			
58	A169010014	PUERTA PEQ CONGEL.AFP-702/802						1		2			
59	6003010074	TAPETA CIEGA NEGRA TROQ 11				1	1	1	1				
60	A167170002	PERFIL ALUM.PUERTA 711X779											2
60	A167170001	PERFIL ALUM.PUERTA 711X1566											1
61	6035130009	CRISTAL PUERTA 693X624 PEQUEÑA											2
61	6035130008	CRIS.PUER 1480X624 CARN.4/15/4										1	
62	6027130001	REJILLA VENT.D.246 PINT Y ZINC							1				
63	6029020008	CONDENSADOR 8X2 REF.C CT82DG			2	2	2						
66	A169010017	PUERTA CARN.CONGEL.AFP TIR.ABS							1				
67	6003010003	TIRADOR NEGRO PUERTA ARMARIO										1	2
68	A109050018	BAND.EVAP.AUTOM.AFP.AFN,AP,APP	1	1	2	2	2	1	1	1	1	1	1
69	A109170041	CUBRE CANAL GALV 800	1	1	2	2	2	1	1	1	1	1	1
70	6021250006	RESIST.BANDEJA 1400 41W	1	1	2	2	2	1	1	1	1	1	1
72	6021010035	COND.ARRANQ SC. 117U5017 80microF						1	1	1			
73	6021010042	RELE ARRANQ. COMPR.SC-12 CL 6005 220V						1					
73	6021010043	RELE ARRANQ. COMPR.SC-15CL 6019							1	1			
74	6021010037	COND.ARRANQ FR. 17U5015 80 microF	1	1								1	1
74	6021010036	CONDENS. ARRANQ TL-G 17U5014 60microF			2	2	1						