

fiamma

ASSISTÊNCIA *TÉCNICA* OFICIAL
Authorised Servicing



Зип Общепит

vsezip.ru

+7(812)987-08-81

FOGÃO ELECTRICO

ELECTRIC COOKING TOP

R01



FOGÃO ECT 2X2 FIAMMA - 2.0.233.0001

ELECTRIC COOKING TOP ECT 2X2 FIAMMA

DIMENSÕES (LxPxH) 745x395x175 mm
DIMENSIONS (LxPxH)

POTÊNCIA 2x2000 W
POWER

TENSÃO DE ALIMENTAÇÃO 230V-50Hz
POWER SUPPLY

ÁREA UTIL DE TRABALHO 2xø 200 mm
WORKING AREA

PESO LIQUIDO 12.5 kg
NET WEIGHT

PESO BRUTO 14.5 kg
GROSS WEIGHT

DIMENSÕES DA EMBALAGEM (LxPxH) 890x605x305 mm
PACKAGE DIMENSIONS



FOGÃO ELÉTRICO ECT FIAMMA

ELECTRIC COOKING TOP

+7(812)987-08-81

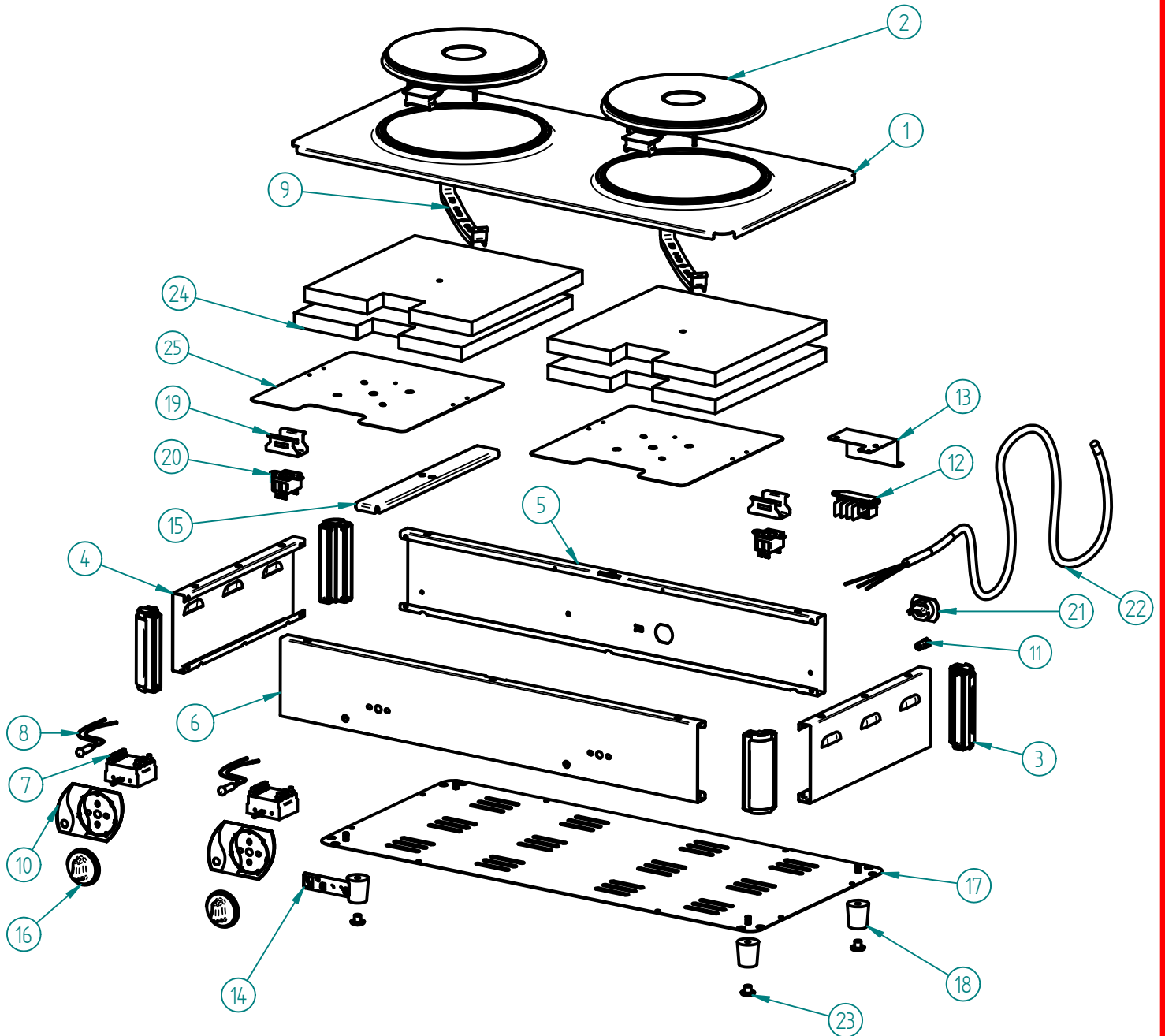

vsezip.ru
FOGÃO ELÉTRICO ECT FIAMMA
 ELECTRIC COOKING TOP
 +7(812)987-08-81

LISTA DE COMPONENTES E ACESSÓRIOS

Spare parts list

ITEM Nº	CÓDIGO	DESIGNAÇÃO	DESIGNATION	QUANT.
1	7.0.233.0050	BASE DISCO FF Ø220 ECT2X2	STOVE SUPPORT ECT2X2	1
2	4.0.232.0060	DISCO FF Ø220 2000W 230V	STOVE Ø220 2000W 230V	2
3	4.0.201.0001	CANTO GL	CORNER GL	4
4	7.0.201.0001	PAINEL LATERAL CG	SIDE PANEL CG	2
5	7.0.233.0006	PAINEL POSTERIOR ECT2X2	REAR PANEL ECT2X2	1
6	7.0.233.0012	PAINEL FRONTAL ECT2X2	FRONT PANEL ECT2X2	1
7	4.0.232.0001	COMUTADOR 7 POS. ECT	COMMUTATOR (7 POS.)	2
8	4.0.066.0025	SINALIZADOR LARANJA TER. PONT. 350MM SL10207	ORANGE LED 350MM	2
9	4.0.232.0061	FIXADOR DISCO FF Ø220	STOVE FASTENER	2
10	4.0.232.0082	PAINEL PERSONALIZADO GL 6-0 - V2	STICKER GL 6-0 - V2	2
11	4.0.125.0020	BORNE Ø10MM	CABLE FASTENER Ø10MM	1
12	4.0.028.0015	LIGADOR RÁPIDO 5 POLOS	FAST LINKER	1
13	7.0.332.0009	SUPORTE LIGADOR RÁPIDO 5 POLOS	FAST LINKER SUPPORT	1
14	4.0.201.0082	ETIQUETA FIAMMA GL (76x19mm)	FIAMMA STICKER	1
15	7.0.233.0031	SUPORTE BASE ECT2X2 / GCT 2 QUEIM.	STOVE SUPPORT	1
16	4.0.066.0101	MANIPULO RST Ø52 C/ MARCA	THERMOSTAT CONTROL KNOB	2
17	7.0.233.0025	BLINDAGEM FUNDO ECT2X2	BOTTOM SHIELD ECT2X2	1
18	4.0.066.0087	PE FENOLICO GRELHADOR	GAS GRILL PLATE FEET	4
19	7.0.201.0055	APOIO TERMOSTATO SEGUR. GL	SECURITY THERMOSTAT SUPPORT GL	2
20	4.0.066.0108	TERMOSTATO SEGURANÇA 150°	SAFETY THERMOSTAT 150°	2
21	4.0.125.0015	CERRA CABOS PA 277	CABLE FASTENER PA277	1
22	4.0.125.0010	CABO H07 RN-F 3G2,5	CABLE H07RN-F 3G2,5	1
23	4.0.000.0878	ANTIDERRAPANTE P/ MAQ. CAFE	ADHERENT RUBBER FOR MACHINE'S FEET	4
24	7.0.232.0060	ISOLAMENTO LA CERAMICA ECT (280x280mm)	CERAMIC INSULATOR ECT (280X280mm)	4
25	7.0.232.0054	BLINDAGEM LA CERAMICA DISCO FF Ø220	BOTTOM CERAMIC INSULATOR ECT	2

FOGÃO ELECTRICO ECT FIAMMA

ELECTRIC COOKING TOP

+7(812)987-08-81

ESQUEMA ELECTRICO Electric Scheme

