

Зип Ощепит

vsezip.ru
+7(812)987-08-81
ESPLOSO RICAMBI
EXPLODED VIEWS

CUBE C537



KRUPPS
DISHWASHER MACHINES 

Зип Общепит

vsezip.ru

+7(812)987-08-81

Тав. C1	CUBE C320 - C
	C537 - C537T -
SRUTTURA / S	

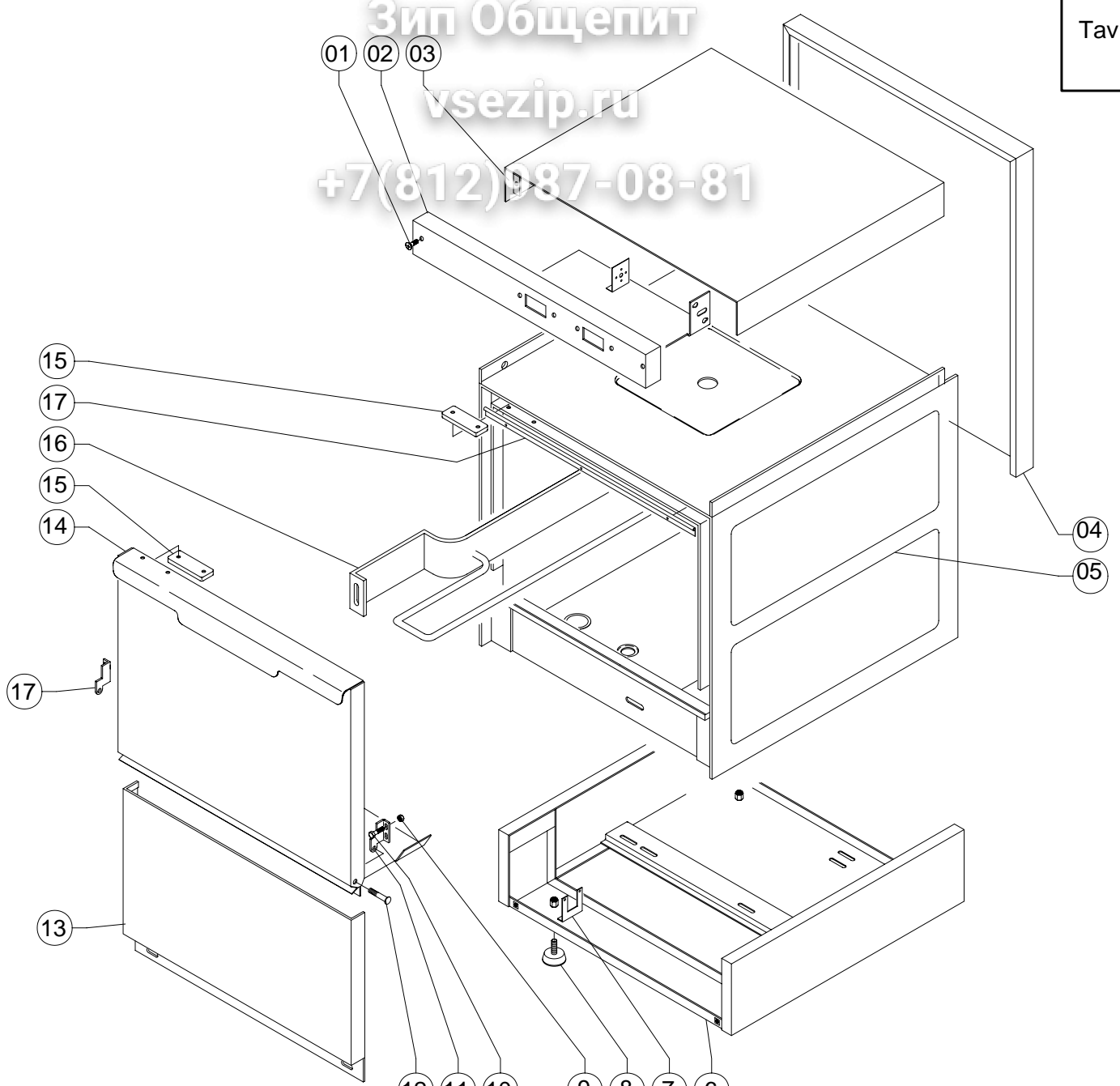

Зип Общепит

vsezip.ru

+7(812)987-08-81

Tav. C4

CUBE C537

GRUPPO POMPE

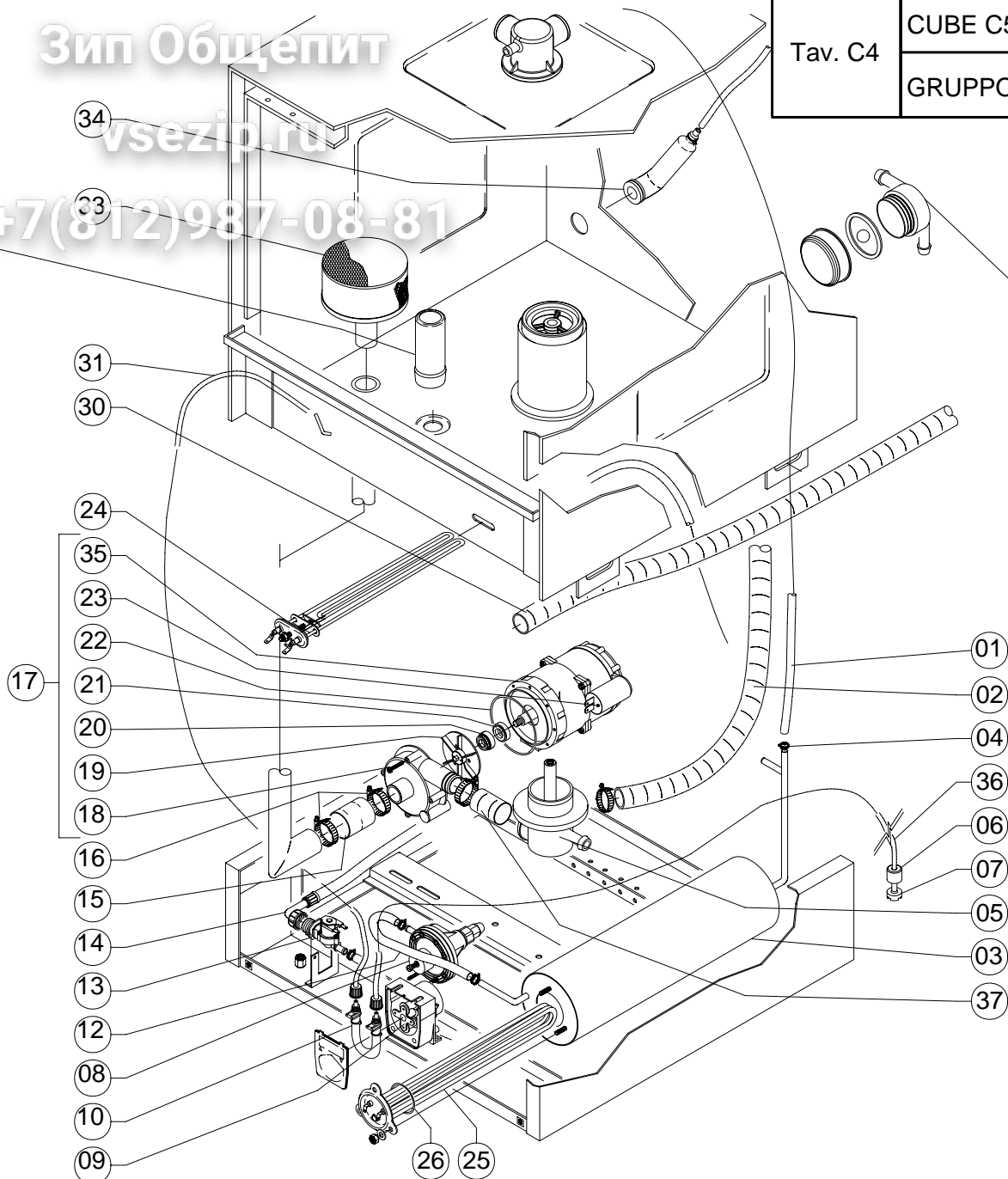
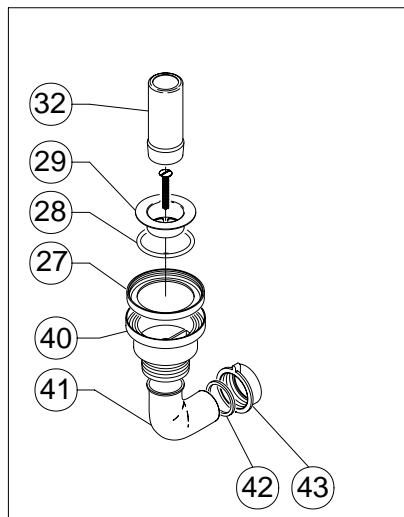

Zip Общепит

POS.	C537	CUBE	DESCRIZIONE	DESCRIPTION	DESCRIPTION	BESCHREIBUNG
1	1380		Tubo di gomma 10-17 90°C al mt.	Rubber hose, 10-17 90°C per metre	Tuyau en caoutch. 10-17 90°C au mètre	Gummischl. 10-17 90°C
2	600720		Tubo lavaggio sup. ø30 mm	Upper rinse pipe, ø30 mm	Tuyau rinçage sup. Ø30 mm	Lausc oberes Nachspülrohr
3	600421		Boiler inox	Stainless steel boiler	Chauffe-eau inox	Boiler aus Edelstahl
4	500		Fascetta inox 10-16	Stainless steel band, 10-16	Collier inox 10-16	Schelle aus Edelstahl
5	104410		Gruppo plastica a perno lungo			
6	1215		Peso per tubetto aspirazione	Weight for intake tube	Poids pour petit tuyau aspiration	Gewicht für Ansaugschlauch
7	1218		Filtro per tubetto aspirazione	Filter for intake tube	Filtre pour petit tuyau aspiration	Filter für Ansaugschlauch
8	1200		Dosatore di brillantante	Rinse doser	Doseur de liquide rinçage	Dosierer für Klarspüler
9	1210K		Dosatore di detergente elett. regolabile	Adjustable electric detergent doser	Doseur détergent électrique réglable	Elektr., einstellb. Dosierapp.
10	1212		Tubetto in santoprene	Santoprene tube	Petit tuyau en santoprène	Kleiner Schlauch aus Santopren
11	103038		Manicotto uscita pompa	Manicotto uscita pompa	Manicotto uscita pompa	Manicotto uscita pompa
12	1381		Tubo gomma 8x15 120°C al mt			
13	103370		Elettrovalvola	Solenoid valve	Electrovanne	Elektroventil
14	1305		Tubo carico acqua da 2.0 mt	Water entry pipe, 2.0 m	Tuyau de remplissage eau de 2.0 m	Wasseransaugschlauch
15			Manicotto ingresso pompa	Pump entry rubber hose	Manchon entrée pompe	Muffe Pumpeneingangsrohr
16	530		Fascetta inox 40-60	Stainless steel band, 40-60	Collier inox 40-60	Schelle aus Edelstahl
17	8100		Motore pompa lavaggio Hp 0,7	Wash pump motor, 0.7 HP	Moteur pompe lavage HP 0,7	Motor Spülpumpe 0,7 HP
18	6210		Chiocciola motore pompa	Pump motor volute	Vis sans fin moteur pompe	Spiralgehäuse Pumpenmotor
19	6211		Girante motore pompa	Pump rotor	Roue pompe	Laufrad Pumpe
20	6014		Guarnizione tenuta rotante	Rotary sealing gasket	Joint d'étanchéité rotatif	Dichtung Laufrad
21	6013		Guarnizione tenuta ceramica	Ceramic sealing gasket	Joint d'étanchéité céramique	Keramikdichtung
22	6212		Guarnizione or per chiocciola pompa	Pump volute OR gasket	Bague torique pour vis sans fin pompe	O-ring-dichtung für Spiralgewindepumpe
23	6215		Condensatore motore	Motor capacitor	Condensateur moteur	Kondensator vom Motor
24	103408		Resistenza vasca 3000 W	Tank heater, 3000W	Résistance cuve 3000 W	Heizschlange Becke
25	103425		Resistenza boiler 3300 W	Tank heater, 3300W	Résistance cuve 3300 W	Heizschlange Becke
26	103415		Guarniz. or per resistenza con flangia	OR heater gasket with flange	Bague torique résistance avec bride	O-Ring-Dichtung Heizer
27	1363		Guarnizione esterna piana	Gasket for discharge drain	Joint pour siphon vidange	Dichtung für Ablauf
28	1361		Guarnizione interna per piletta inox	OR gasket	Bague torique	O-Ring-Dichtung
29	1360		Piletta inox da 1" 1/2	Inox drain, 1" 1/2	Siphon inox de 1" 1/2	Inoxblauf 1" 1/2 Zoll
30	1320		Tubo di scarico ø32 mm	Discharge pipe, ø32 mm	Tuyau de vidange ø32 mm	Abflußschlauch ø32 mm
31	1421		Tubetto 6x4 giallo per DD			
32	800101		Tubo troppo pieno	"Too full" pipe,	Tuyau trop-plein	Überlaufschlauch
33	3250		Filtro inox	Stainless steel filter	Filtre inox	Filter für Edelstahl
34	3280		Trappola d'aria	Air trap	Prise d'air	Luftfalle
35	8113		Flangia motore pompa	flange wash pump	Bride moteur pompe	Flansch Pumpenmotor
36	1420		Tubetto 6x4 azzurro per DB			
37			Manicotto uscita pompa			
40	1362		Raccordo polietilene	Joint	Raccord	Anschluss
41	1365		Codolo curvo scarico da 40 mm	Curved discharge shaft, 40 mm	Extrémité coude vidange de 40mm	Gebogenes Endstück
42	1366		Guarnizione codolo	Gasket	Joint	Dichtung
43	1367		Dado per codolo di scarico da 1" 1/2G	Nut for discharge shaft, 1"1/2G	Ecrou pour extrémité tuyau de vidange de 1" 1/2G	Mutterschraube für Endstück
44	1500		Valvola antiriflusso			

Зип Общепит

vsezip.ru

+7(812)987 08 81

Тав. C8	CUBE C432 - C4
	GIRANTE / WAS

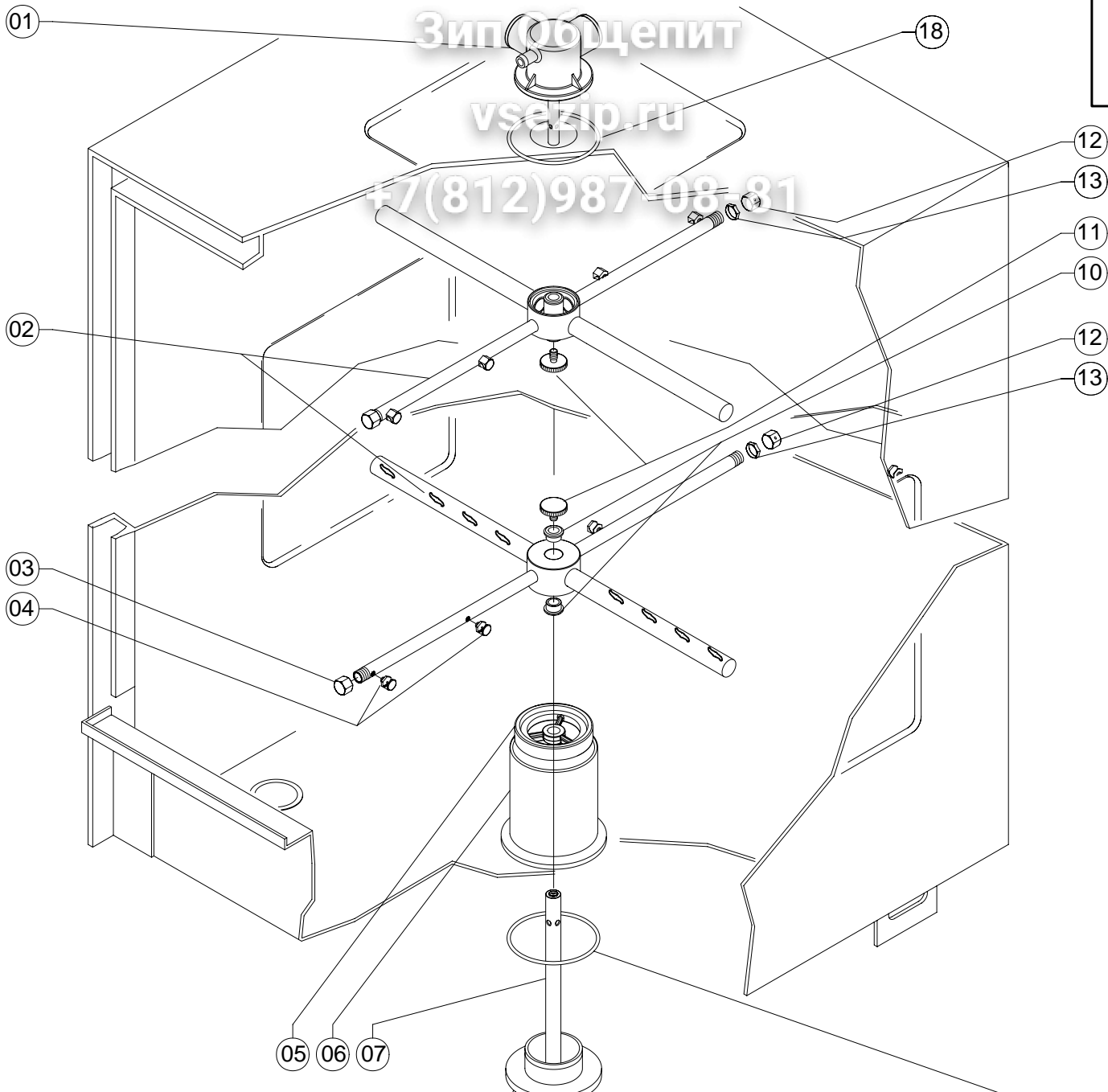

Зип Общепит

vsezip.ru

+7(812)987-08-81

Тав. С10

CUBE C320-C32

IMPIANTO ELET

ELECTRICAL C

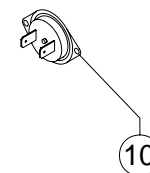
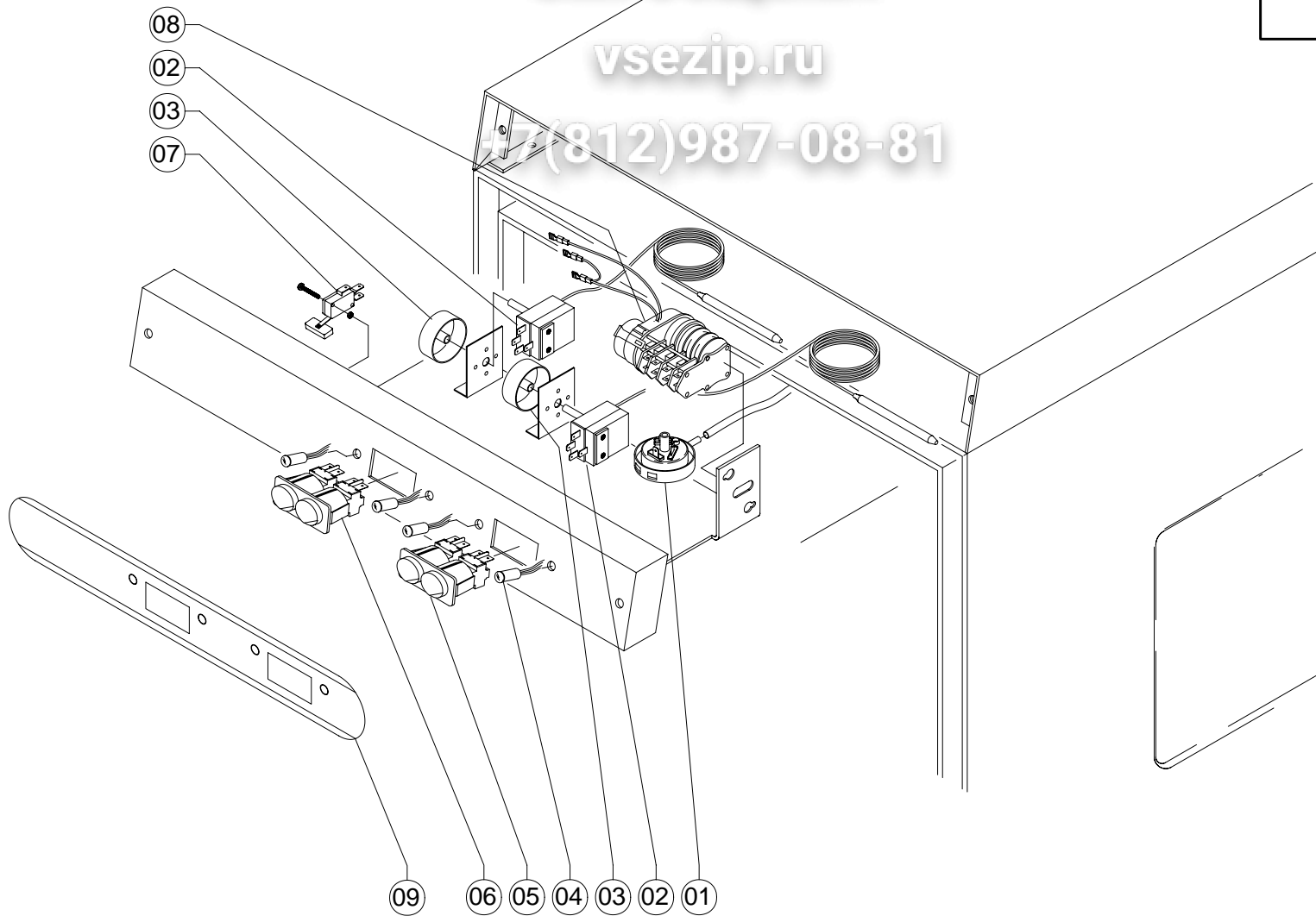

Зип Общепит

vsezip.ru

+7(812)987-08-81

Тав. С15

CUBE C537 - C5

CESTELLI / BAS

01

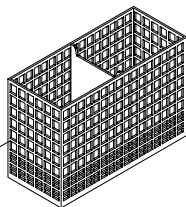

05

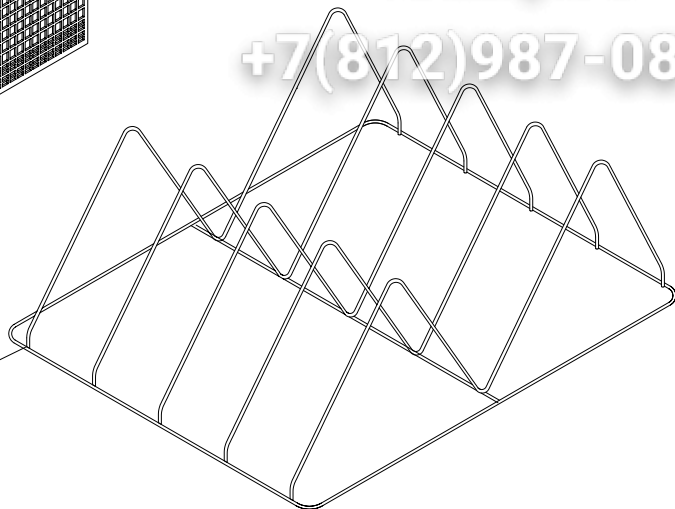

02

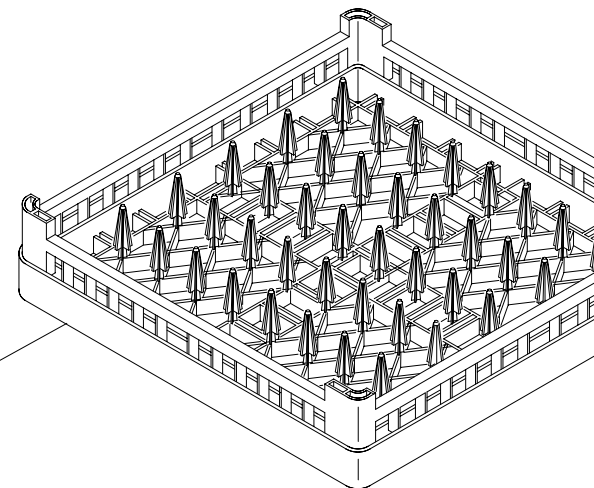

03

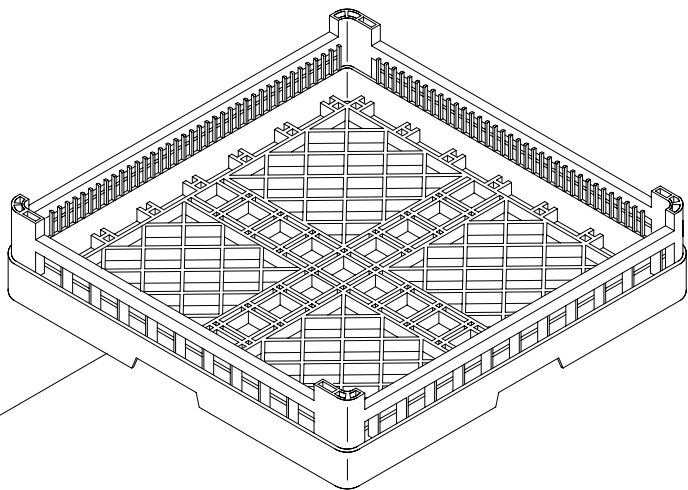

04

