

CME256 or CME506 or CME656 or CME806 Service Parts

This parts list contains service part information for 8 basic models, plus 4 different electrical configurations. **The complete model number will be needed to identify the correct part.**

Model Series Changes (code at end of model number)

- C series - changes to the front & side panels
- D series - changes to the top panel and to the compressor starting components
- E series - new side panels and 2 TXVs with check valves for the CME506
- F series - new water cooled condensers
- H series - color change

Electrical Codes are located at the end of the model number (voltage/hertz/phase):

- -1 is 115/60/1
- -32 is 208-230/60/1
- -3 is 208-230/60/3
- -6 is 250/50/1

Electrical Components Common to All Machines:

- Inlet water valve
- Water sensor
- Discharge line sensor
- Controller
- Ice sensor/bin controls
- Water level sensor

Unique Electrical Components

- Compressor and related starting components
- Contactor (single / three phase)
- Fan motor
- Water pump
- Transformer
- Hot gas valve

Other Unique parts include: side panels, electrical, refrigeration and some water system items.

TABLE OF CONTENTS

<p>Cabinet PAGE 2</p> <p>Interior Structure & Controls PAGE 3</p> <p>CME256 Air Cooled Refrigeration PAGE 4</p> <p>CME506 A - D Series Air Cooled Refrigeration PAGE 5</p> <p>CME506 E - H Series Air Cooled Refrigeration PAGE 6</p> <p>CME656 Air Cooled Refrigeration PAGE 7</p> <p>CME806 Air Cooled Refrigeration PAGE 8</p> <p>Water System Components PAGE 9</p> <p>CME256 Water Cooled Refrigeration PAGE 10</p> <p>CME506 A - D Series Water Cooled Refrigeration PAGE 11</p> <p>CME506 E - H Series Water Cooled Refrigeration PAGE 12</p> <p>CME656 Water Cooled Refrigeration PAGE 13</p> <p>CME806 Water Cooled Refrigeration PAGE 14</p> <p>Compressors and Electrical Components for CME256 and CME506 PAGE 15</p> <p>Compressors and Electrical Components for CME656 and CME806 PAGE 16</p> <p>HTB555 Ice Storage Bin PAGE 17</p> <p>D thru H Series Single Phase 60 Hz Schematic Diagram PAGE 18</p> <p>D thru H Series, 115 volt CME256 and CME506 Wiring Diagram PAGE 19</p> <p>D thru H Series CME656 or CME806 Single Phase Wiring Diagram PAGE 20</p> <p>D thru H Series CME656 Three Phase Wiring Diagram PAGE 21</p> <p>D thru H Series, 230 volt, 60 Hz. CME256 and CME506 Diagram PAGE 22</p> <p>A - C Series Single Phase Air Cooled Schematic Diagram PAGE 23</p>	<p>A - C Series CME256 and CME506 Air Cooled Wiring Diagram PAGE 24</p> <p>A - C Series Water Cooled Single Phase Schematic Diagram PAGE 25</p> <p>A - C Series CME256 and CME506 Water Cooled Wiring Diagram PAGE 26</p> <p>A - C Series CME656 or CME806 Air Cooled Single Phase Wiring Diagram PAGE 27</p> <p>A - C Series CME656 Water Cooled Single Phase Wiring Diagram PAGE 28</p> <p>A - H Series Three Phase Air Cooled Schematic Diagram PAGE 29</p> <p>A - C Series CME656 Air Cooled Three Phase Wiring Diagram PAGE 30</p> <p>A - H Series CME656 Three Phase Water Cooled Schematic Diagram PAGE 31</p> <p>A - C Series CME656 Three Phase Water Cooled Wiring Diagram PAGE 32</p> <p>D thru H Series CME506 50 Hz Air Cooled Diagram PAGE 33</p> <p>D thru H Series CME506 50 Hz Water Cooled Diagram PAGE 34</p> <p>D thru H Series CME656 or CME806 50 Hz Air Cooled Diagram PAGE 35</p> <p>D thru H Series CME656 or CME806 50 Hz Water Cooled Diagram PAGE 36</p> <p>B or C Series 50 Hz Water Cooled CME506 Diagram PAGE 37</p> <p>B or C Series, 50 Hz Air Cooled CME656 and CME806 Diagram PAGE 38</p> <p>B or C Series, 50 Hz Water Cooled CME656 and CME806 Diagram PAGE 39</p> <p>B or C Series, 50 Hz Air Cooled CME506 Diagram PAGE 40</p> <p>D thru H Series, 50 Hz CME256 Diagram PAGE 41</p>
--	--

CME256 or CME506 or CME656 or CME806 Service Parts Cabinet

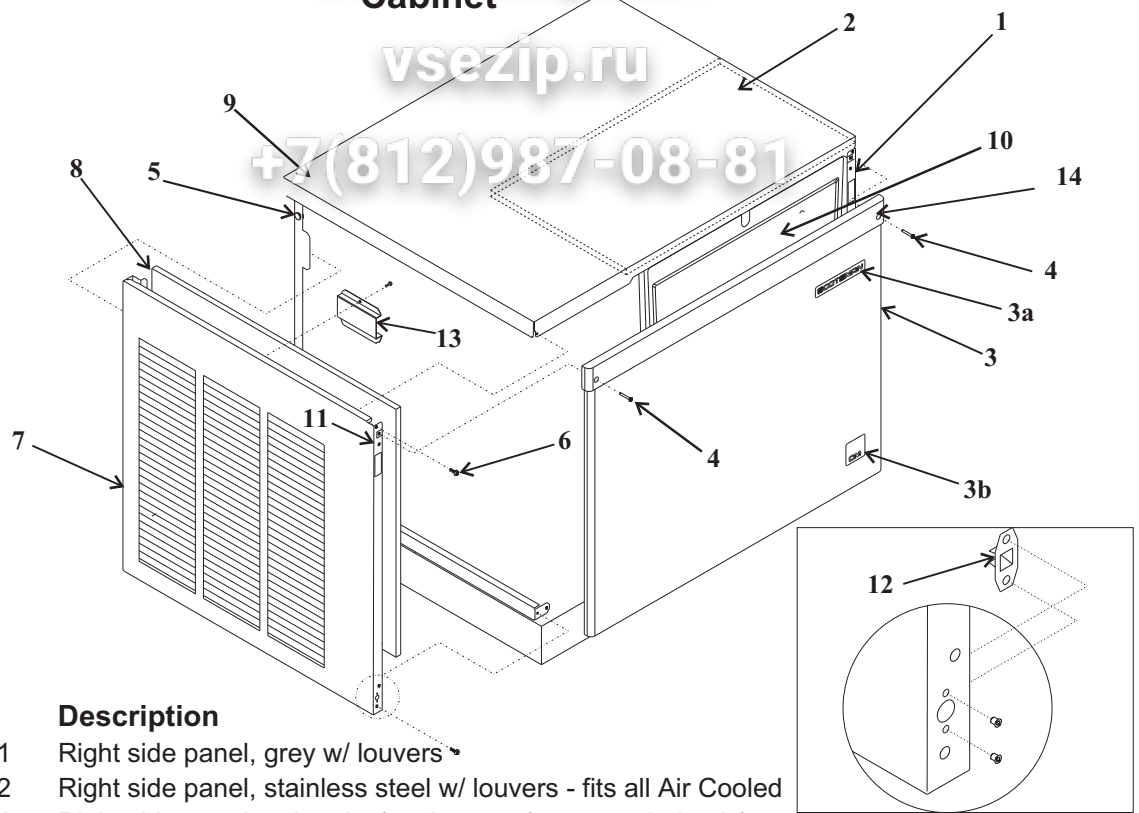

Item Number	Part Number	Description	
1	A35963-021	Right side panel, grey w/ louvers	
	A35963-022	Right side panel, stainless steel w/ louvers - fits all Air Cooled	
	A37071-021	Right side panel, painted w/out louvers (water cooled only)	
	A37071-022	A - D series right side panel, stainless steel without louvers (water cooled only)	
	A38126-021	E - H series right side panel, w/out louvers for water cooled only	
2	02-3659-01	Top insulation	
	02-3797-21	C series Front panel kit, gray plastic , includes trim strip & emblems	
3	03-1733-01	Strike (for C to H series panel, SS or plastic)	
	A37167-001	Front panel kit, SS, replaces gray plastic or SS, includes item 10a (for A series)	
	A37488-031	C to H series Front panel kit, stainless steel , includes trim strip & emblems	
3a	15-0808-01	Emblem for ss panel (Scotsman); 03-0271-00 is the speed nut for emblem	
3b	15-0792-02	Emblem for C to H series front panel, (CM ³)	
4	03-1735-01	Screw for trim strip (for C to H series)	
	03-1404-12	Sheet metal screw for plastic front panel (for A series)	
	03-1419-22	Sheet metal screw for ss front panel	
5	02-1875-03	Panel bumper/hole plug	
	03-1531-01	Sheet metal screw	
7	A35962-021	Left side panel, grey enamel with louvers	
	A35962-022	Left side panel, stainless steel with louvers	
	A37070-021	Left side panel, grey enamel without louvers (water cooled only)	
	A37070-022	A - D series left side panel, stainless steel without louvers (water cooled only)	
	A38127-021	E - H series left side panel, w/out louvers for water cooled only	
8	02-3485-01	Air filter, air cooled only	
	9	A35965-001	Top panel, grey enamel, order item 2 also
		A35965-002	Top panel, stainless steel, order item 2 also
10a	02-3822-21	Top panel, plastic, fits all, original to H series	
	02-3663-01	Evaporator cover, use began Feb. 1997. Fits A and B series	
	02-3796-01	Insulation for above cover	
11	02-3663-20	Evap cover w/ ins for C - H series	
	13	A37326-001	Filter bracket
11	03-1423-06	Speed nut for panel screws	
12	03-1733-02	Catch	
	14	02-3794-31	Trim strip. 03-1731-02 is the push nut for trim strip

Interior Structure & Controls

Note: Item 25 mounts to Item 1.
Item 1 must have rectangular mounting tabs. All units after 9/96 were mfg. with rectangular tabs.

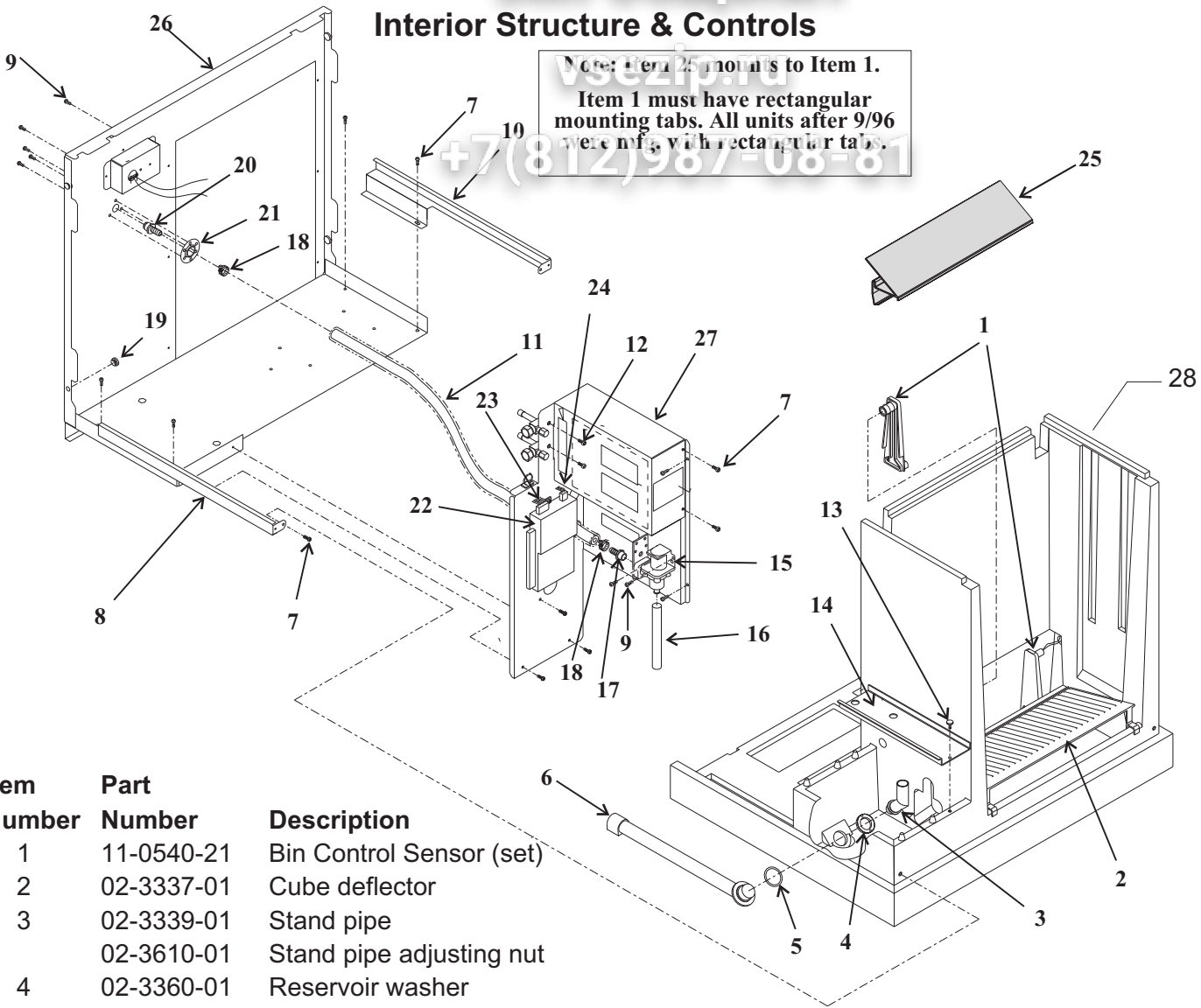

Item Number	Part Number	Description
1	11-0540-21	Bin Control Sensor (set)
2	02-3337-01	Cube deflector
3	02-3339-01	Stand pipe
	02-3610-01	Stand pipe adjusting nut
4	02-3360-01	Reservoir washer
5	13-0617-56	O-ring
6	02-3338-01	Drain tube & fittings
7	03-1404-18	Screw
8	A36298-001	Left side channel
9	03-1531-01	Screw
10	A36297-001	Right side channel
11	13-0906-01	Plastic inlet water hose, 21" req. order 2 units - not used after Sept. 1996
12	03-1645-01	Screw
13	03-1691-01	Nylon screw
14	02-3340-01	Reservoir cover
15	12-2548-01	Inlet water valve
16	13-0674-02	Tubing, 9" req., order 1 unit
17	02-3443-01	Water fitting for hose
	16-1020-01	Water fitting for copper
18	02-0179-05	Clamp
19	13-0903-01	Bumper for side panels
20	16-0997-01	Inlet water fitting for hose
	16-1019-01	Inlet water fitting for copper
21	16-0701-07	Mounting flange
22	12-2838-23	AutoIQ controller
23	12-2644-21	Low voltage harness A - C series
	12-2782-21	Low volt harness, D + series 60 Hz
	12-2782-23	Low volt harness, D + series 50 Hz
24	12-2618-01	Hi volt harness, w fan control A series
	12-2476-01	Hi volt harness for w/o fan control A-C
	12-2678-01	Hi volt harness for 50 Hz models A-C
	12-2784-21	Hi volt harness for D + series 60 Hz.
	12-2786-21	Hi volt harness for D + series 50 Hz.
25	02-3657-01	Cascading shield, used on CME806, 656 and 506 after 2/97
26	A36460-001	Back panel assy (ac)
	A36460-003	Back panel assy (wc)
27	A35959-001	Hi voltage box cover
28	A36457-001	Foamed base

CME256 Air Cooled Refrigeration

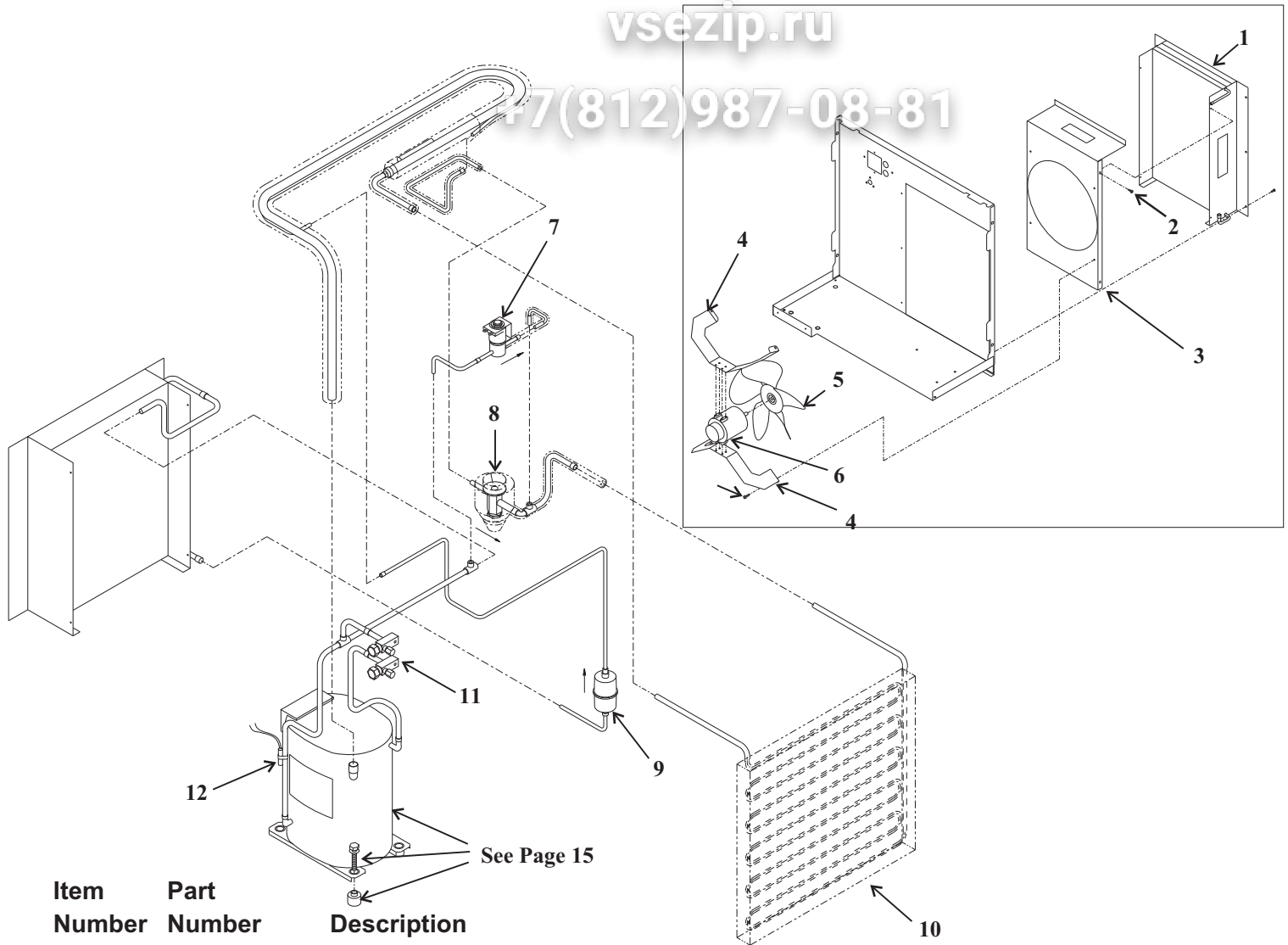

Item Number Part Number Description

1	18-8745-01	Condenser
2	03-1531-01	Screw
3	A36031-001	Shroud
4	A36668-001	Motor bracket
5	18-8503-01	Fan blade
6	18-5505-01	Fan motor for 115 volt, 60 Hz
	18-5505-12	Fan motor for 230 volt, 50 Hz
	18-5505-11	Fan motor for 230 volt, 60 Hz
7	12-2471-01	Hot gas valve w/coil
	12-2719-23	Hot gas valve coil only
8	16-1009-22	TXV
	02-4406-01	Insulation for TXV
9	02-3319-01	Dryer
10	A36734-020	Evaporator
11	16-0832-21	Access valve
11a	16-0832-03	Port cap
11b	16-0832-02	Stem cap
12	02-3410-21	Temp sensor, incl. water temp sensor & clip
	03-1711-01	Sensor clip
13	16-1063-02	Hot gas valve strainer (not shown)

For models with a fan control switch:
The part number of the fan control pressure switch is: 11-0508-21

Water System Components

Зип Общепит
vsezip.ru

+7(812)987-08-81

Single Evaporator Models

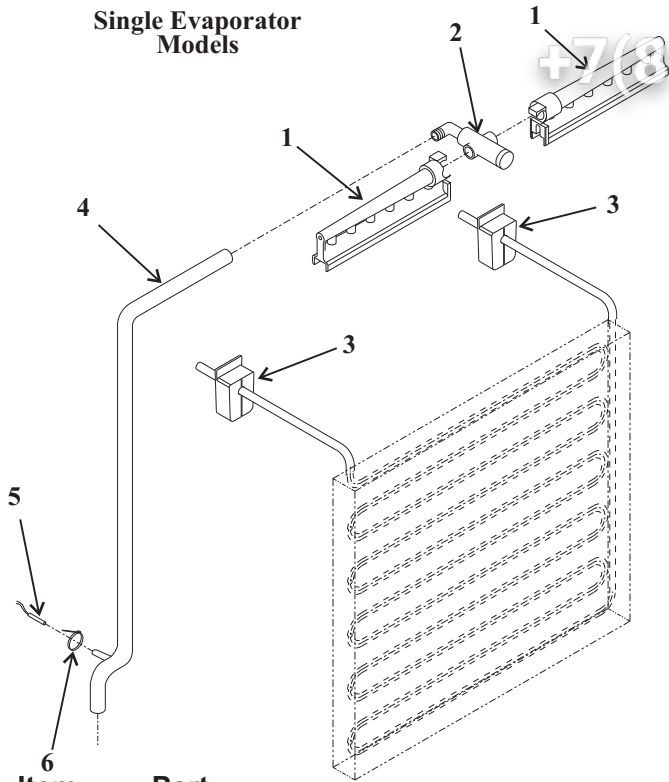

Two Evaporator Models

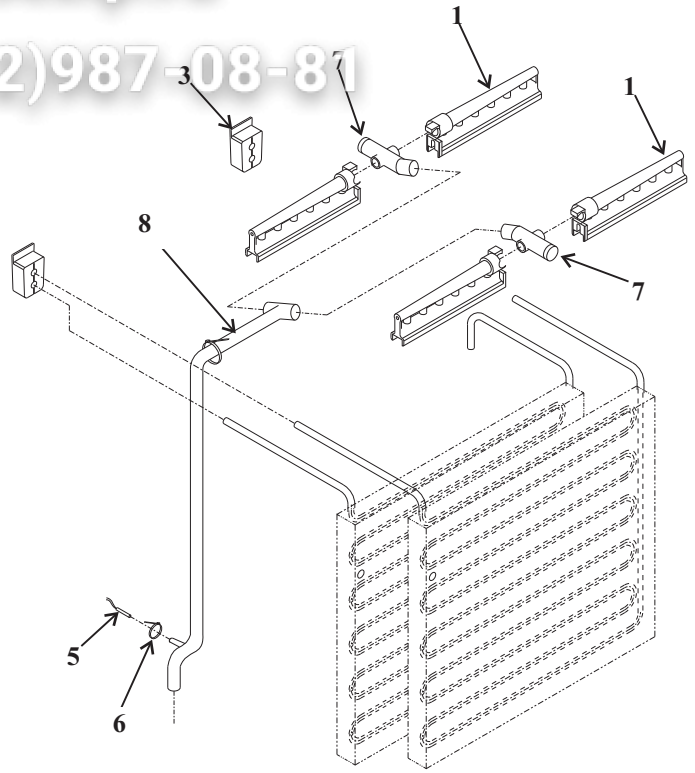

Item Number	Part Number	Description
1	02-2527-01	Water distributor
2	A30926-001	Distributor manifold
3	13-0898-02	Tubing grommet
4	02-3361-01	Water discharge tube for single evaporator models
5	02-3410-21	Water temperature sensor includes disch. temp. sensor
6	no number	Cable tie
7	02-3405-01	Inlet Tee
8	02-3336-01	Water distributor tube for double evaporator models
9	02-3383-01	Float stem, 1 evaporator model*
	02-3383-02	Float stem, 2 evaporator model*
10	11-0539-51	Float (water level) sensor
11	02-3388-04	Front pump bracket for 12-2586 type pump
12	02-3388-05	Rear pump bracket for 12-2586 type pump
13	12-2506-01	Harness
14	02-3341-01	Float
15	12-2586-21	CME256-1 (115 volt) pump
	12-2586-27	CME506-1 (115 volt) pump
	12-2586-26	CME256-6 or -32 (208-230 volt),
	12-2586-23	CME506-6 or 32 (208-230 volt),
		CME656 or CME806 (208-230 volt) pump. 50 or 60 Hz.

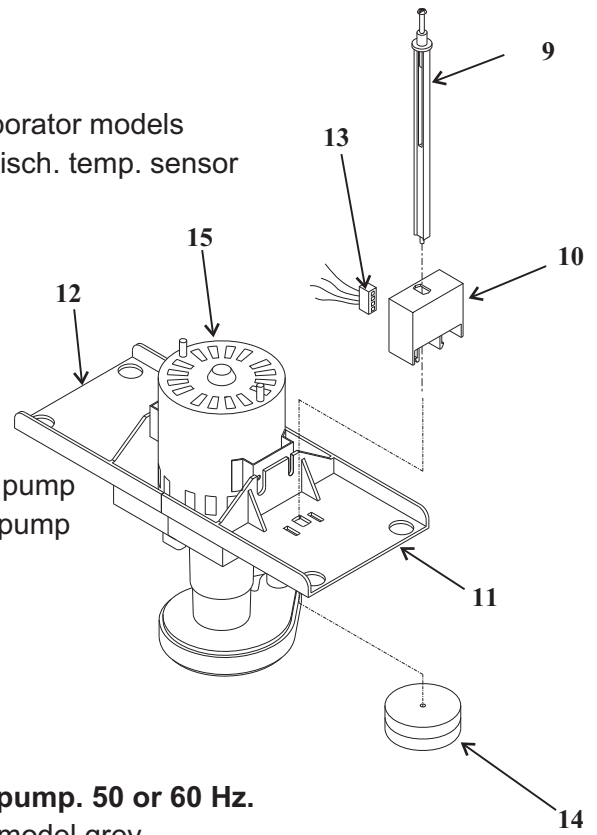

* Not adjustable after 2/97. Then 1 evap model white, 2 evap. model grey.

CME256 Water Cooled Refrigeration

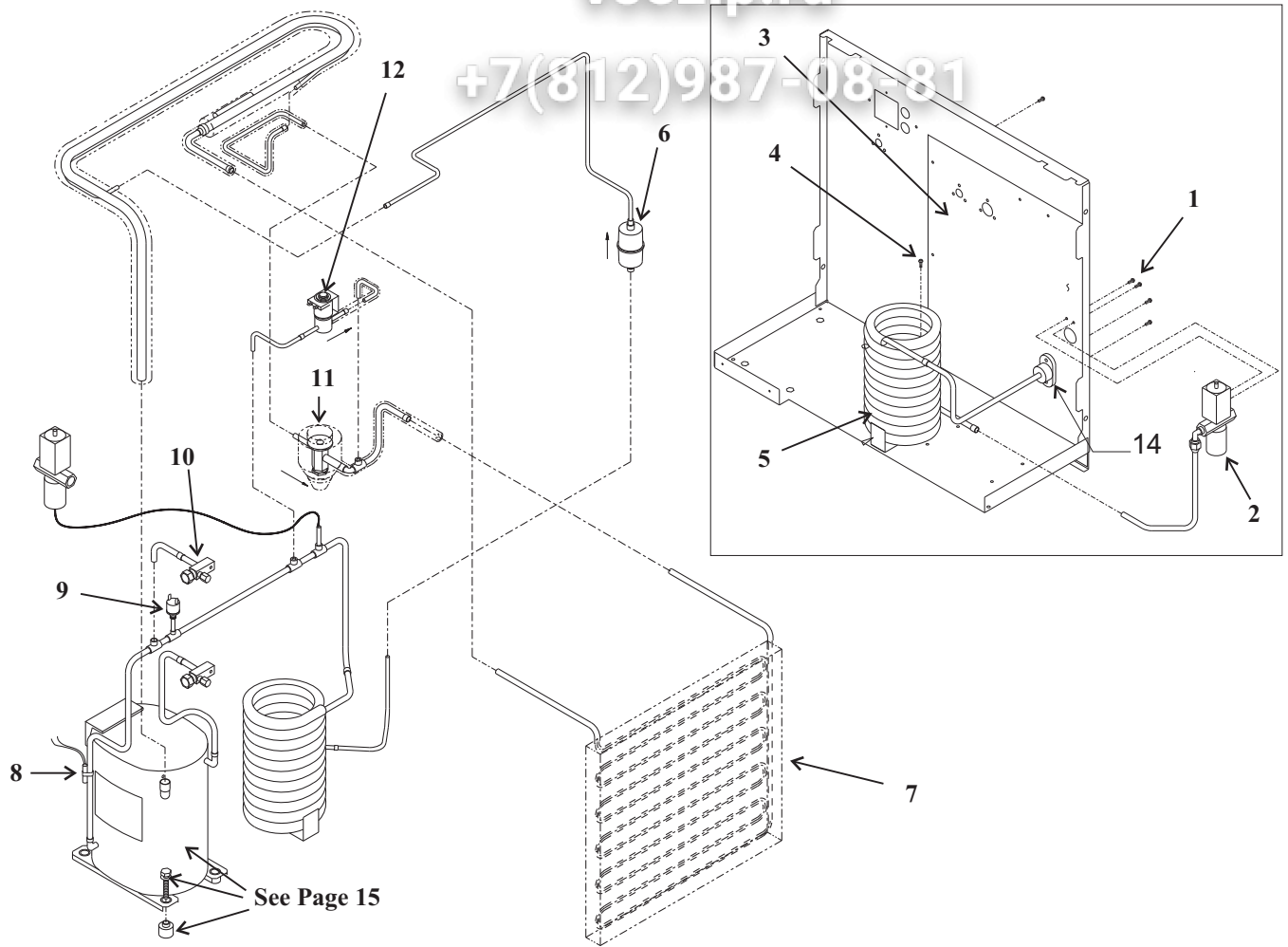

Item Number	Part Number	Description	Item Number	Part Number	Description
1	03-1403-15	Screw	12	12-2471-01	Hot gas valve w/coil
2	11-0478-01	Water regulating valve		12-2719-23	Hot gas valve coil only
3	A36440-001	Back cover	13	16-1063-02	Hot gas valve strainer (not shown)
4	03-1645-01	Screw	14	A31828-001	Fitting
5	18-3306-25	Condenser, A thru E series			
	18-8871-21	Condenser, F series			
6	02-3319-01	Dryer			
7	A36734-020	Evaporator			
8	02-3410-21	Hi temperature sensor, includes water temp sensor & clip			
	03-1711-01	Clip for sensor			
9	11-0501-21	Hi pressure cut out			
10	16-0832-21	Access valve			
10a	16-0832-03	Port cap			
10b	16-0832-02	Stem cap			
11	16-1009-22	TXV 1/4 ton			
	02-4406-01	Insulation for TXV			

Compressors and Electrical Components for CME256 and CME506

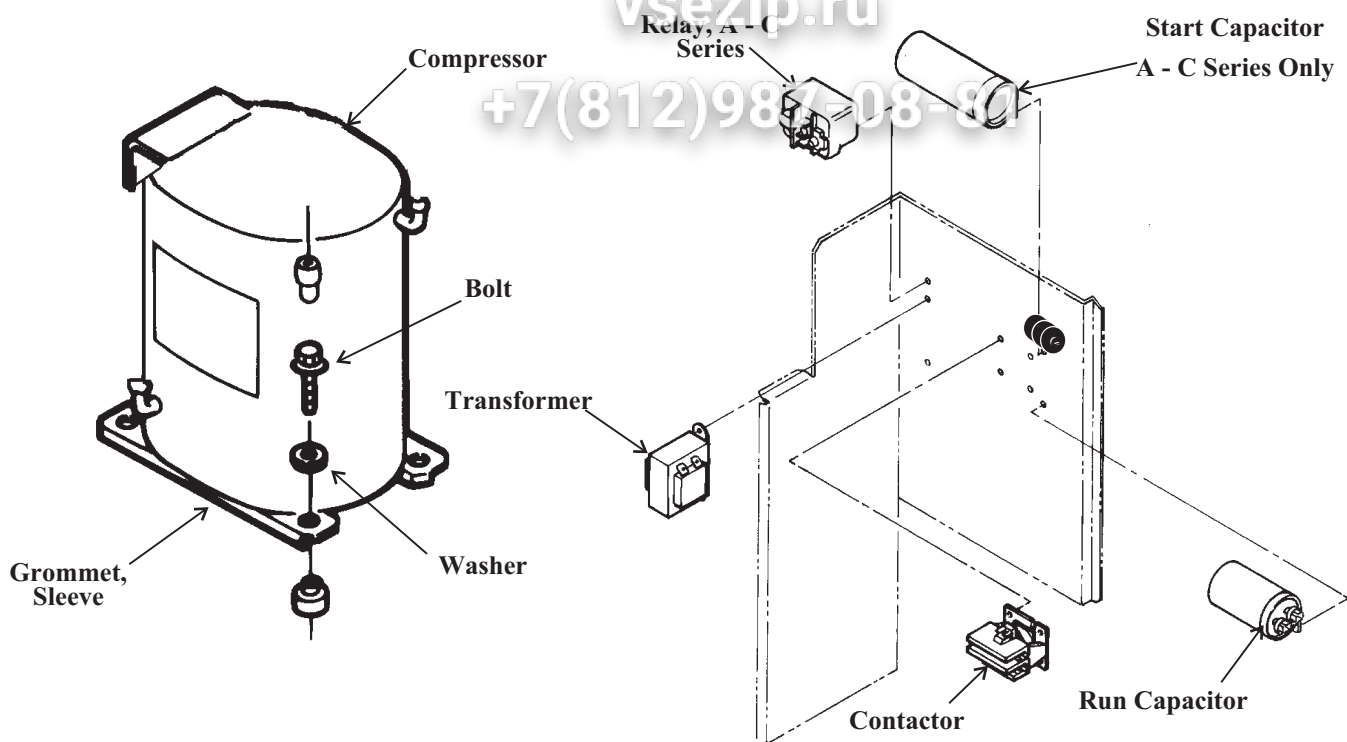

Model	CME256			CME506		
	115/60	208-230/60	230/50	115/60	208-230/60	230/50
Voltage/Hz	115/60	208-230/60	230/50	115/60	208-230/60	230/50
Phase	Single	Single	Single	Single	Single	Single
Compressor	18-8720-21*	18-8838-23*	18-8838-22	18-8721-21*	18-8839-23*	18-8721-22
PTCR - D thru F series only	18-8835-01	18-8835-01	18-8835-01	18-8835-01	18-8835-01	18-8835-01
Start Relay**	18-1903-44	not used	not used	18-1903-50	not used	18-1903-29
Start Capacitor**	18-1901-49	not used	18-2200-35	18-1901-03	not used	18-1901-43
Run Capacitor	18-1902-52	18-1902-17	not used	18-1902-45	18-1902-45	18-1902-30
Overload	18-5700-50	18-8838-50	18-5700-55	18-8711-50	18-8839-50	18-8721-50
Mounting Bolt	03-1405-20	03-1405-20	03-1405-20	03-1405-20	03-1405-20	03-1405-20
Sleeve	18-2200-27	18-2200-27	18-2200-27	18-2200-27	18-2200-27	18-2200-27
Washer	03-1407-07	03-1407-07	03-1407-07	03-1407-07	03-1407-07	03-1407-07
Grommet	18-2200-28	18-2200-28	18-2200-28	18-2200-28	18-2200-28	18-2200-28
Contactora	12-2469-01	12-2469-01	12-2469-01	12-2469-01	12-2469-01	12-2469-01
Transformer	A37231-001	A37217-001	12-2639-02	A37231-001	A37217-001	A37217-001

* Includes starting components. All compressors include a drier. ** D thru F series uses PTCR

-6B, C, D, E, F series	Transformer	Hi Voltage Harness	Fuse	Fuse Block	Relay	Relay Bracket
CME256 or CME506	12-2639-02	12-2678-21	12-2686-01	12-2687-01	12-2679-01	12-2680-01

HTB555 Ice Storage Bin

Зип Общепит

vsezip.ru

+7(812)987-08-81

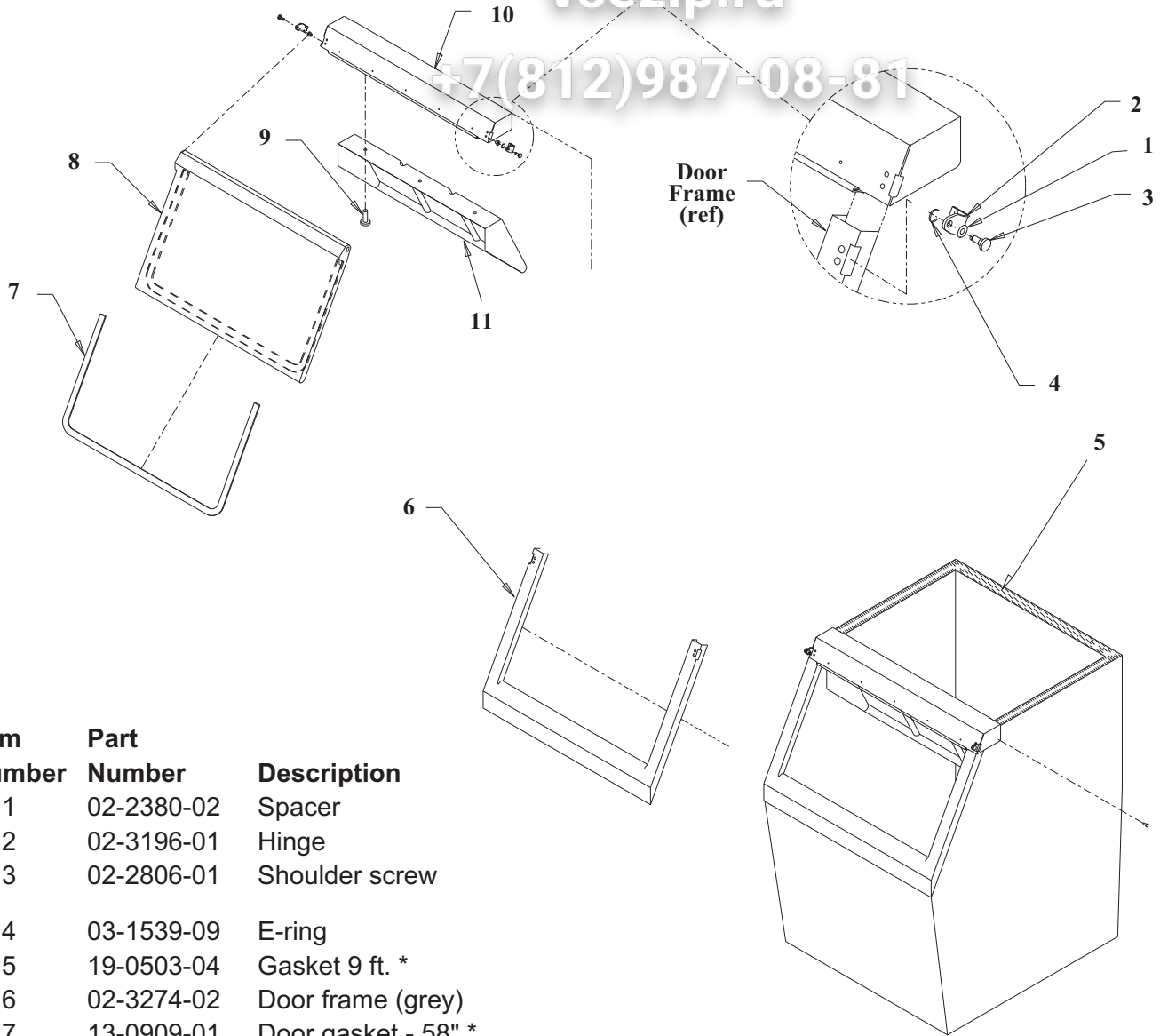

Item Number	Part Number	Description
1	02-2380-02	Spacer
2	02-3196-01	Hinge
3	02-2806-01	Shoulder screw
4	03-1539-09	E-ring
5	19-0503-04	Gasket 9 ft. *
6	02-3274-02	Door frame (grey)
7	13-0909-01	Door gasket - 58" *
8	A36481-022	Door, grey, includes #7.
9	03-0727-11	Thumb screw
10	A35637-001	Canopy
11	A35640-001	Baffle
12	02-2809-02	Drain top
13	13-0617-09	O-ring
14	02-3108-01	Drain bottom

Not shown

- 03-1404-07 Screw for drain bottom
- 05-0586-01 Drain elbow
- 02-0540-00 Scoop
- KLP2E Enamel leg kit

* Order gasket by the foot.
 Optional: A35477-001 Scoop holder, not shown

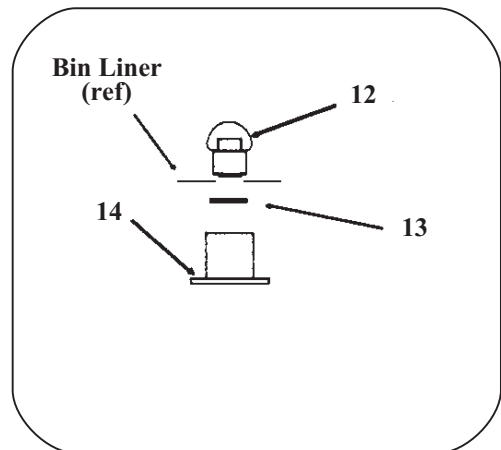

D thru H Series Single Phase 60 Hz Schematic Diagram

Зип Общени
vsezip.ru

+7(812)987-08-81

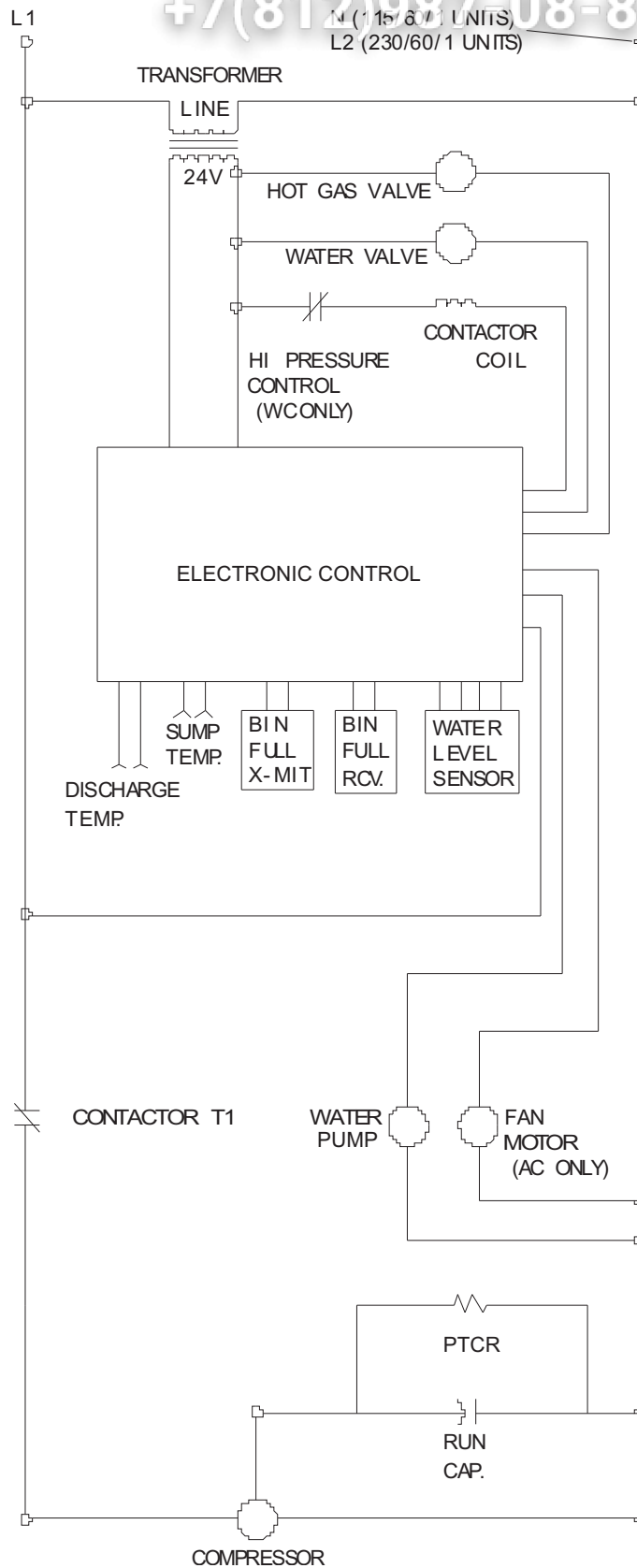

CME256 or CME506 or CME656 or CME806 Service Parts

D thru H Series, 115 volt CME256 and CME506 Wiring Diagram

vsezip.ru

+7(812)987-08-81

17-2747-01

USE COPPER CONDUCTORS ONLY

⚠ DASHED LINES INDICATE FIELD WIRING WHICH MUST BE INSTALLED IN ACCORDANCE WITH THE NATIONAL ELECTRICAL CODE AND ALL STATE AND LOCAL CODES.

CAUTION: PTCR WILL BE HOT. COMPRESSOR MAY NOT START IF PTCR IS NOT ALLOWED TO COOL.

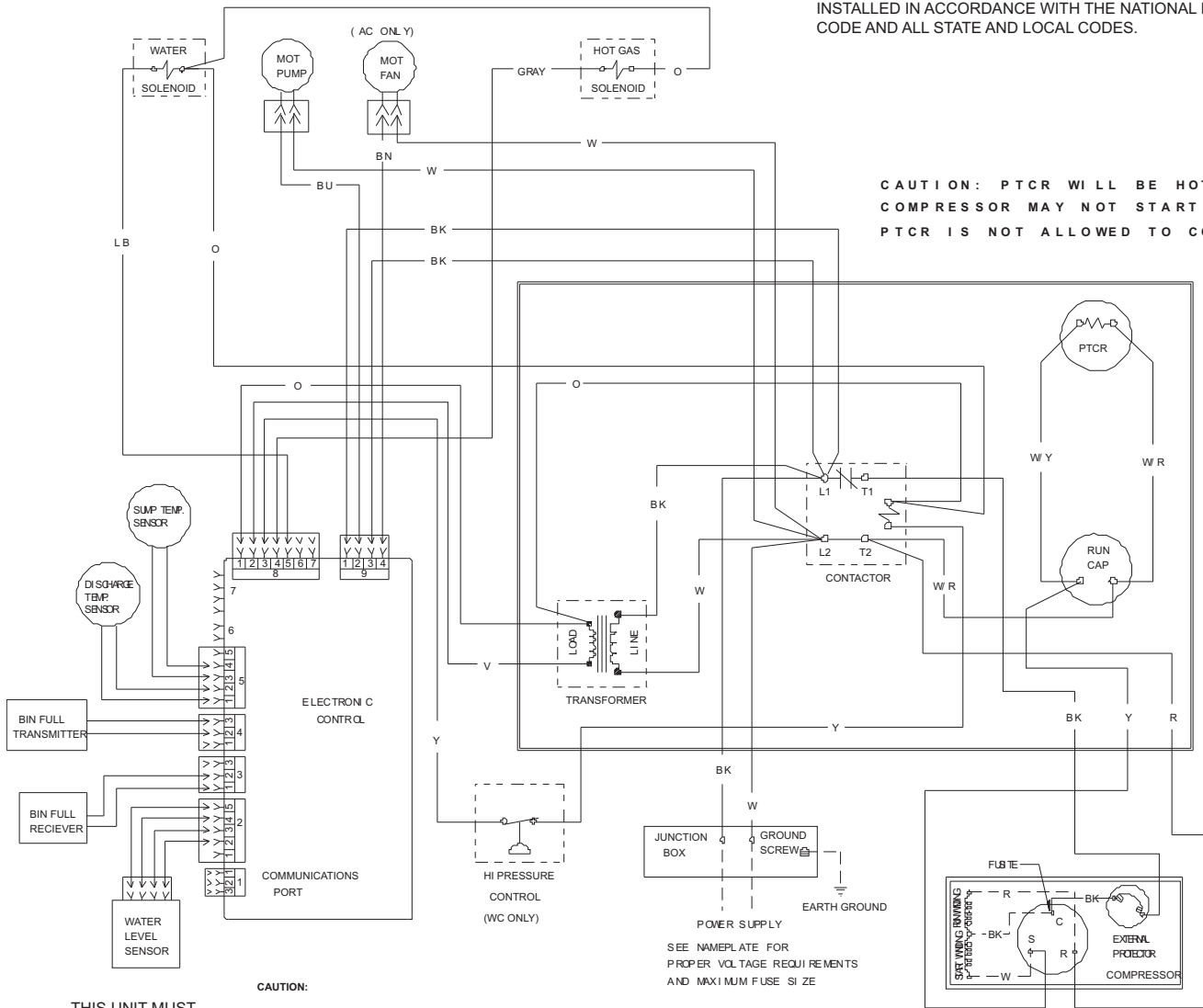

THIS UNIT MUST BE GROUNDED.

CAUTION:
MORE THAN ONE DISCONNECT MEANS MAY BE REQUIRED TO DISCONNECT ALL POWER TO THIS UNIT.

POWER SUPPLY
SEE NAMEPLATE FOR PROPER VOLTAGE REQUIREMENTS AND MAXIMUM FUSE SIZE

D thru H Series, 230 volt, 60 Hz. CME256 and CME506 Diagram

Зип Общени
vsezip.ru

+7(812)987-08-80

△ WIRING LINES INDICATE FIELD WIRING WHICH MUST BE INSTALLED IN ACCORDANCE WITH THE NATIONAL ELECTRICAL CODE AND ALL STATE AND LOCAL CODES.

USE COPPER CONDUCTORS ONLY

17-2863-01

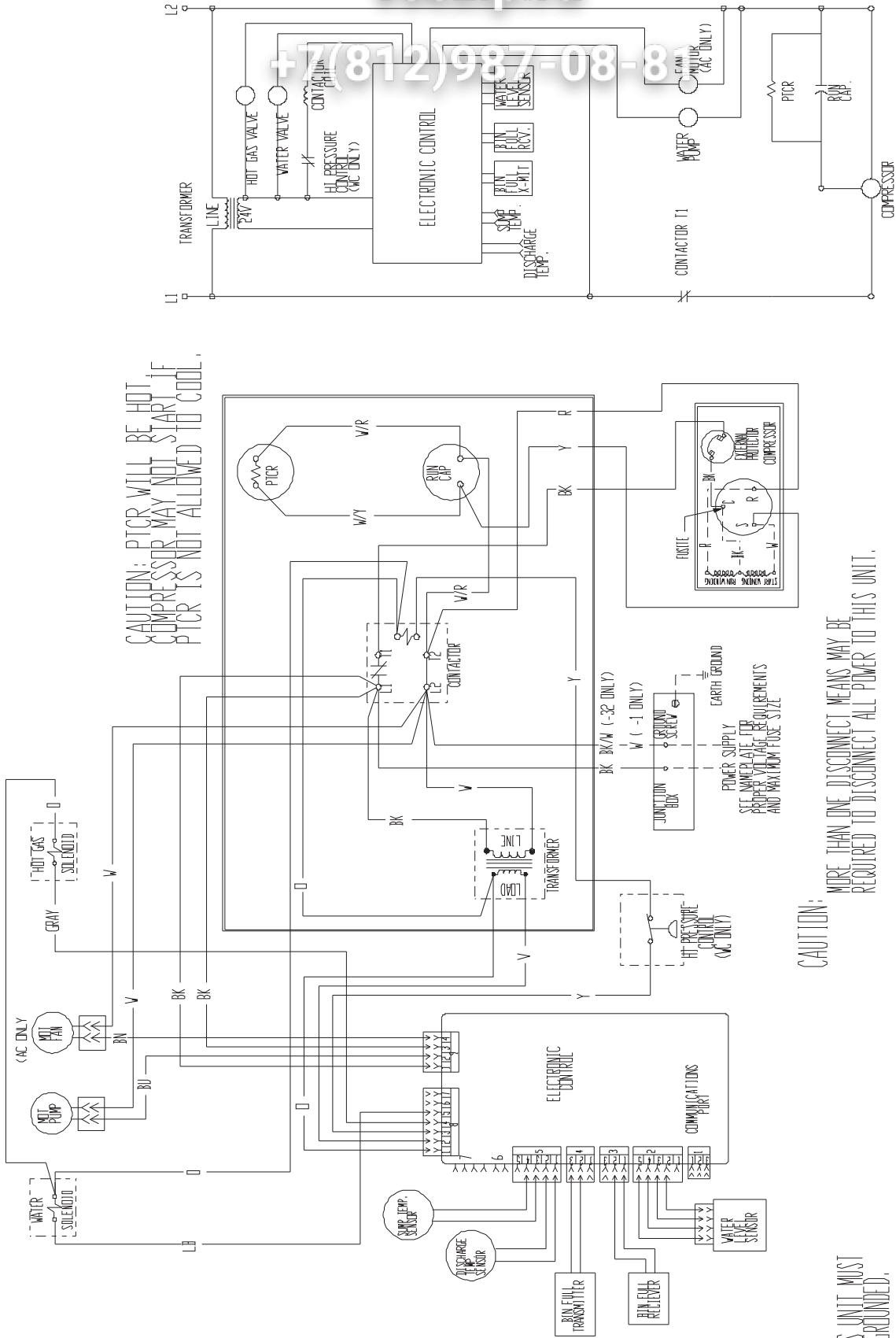

CAUTION: PTCR WILL BE HOT. COMPRESSOR MAY NOT START IF PTCR IS NOT ALLOWED TO COOL.

CAUTION: MORE THAN ONE DISCONNECT MEANS MAY BE REQUIRED TO DISCONNECT ALL POWER TO THIS UNIT.

THIS UNIT MUST BE GROUNDED.

A - C Series Single Phase Air Cooled Schematic Diagram

vsezip.ru
N (115/60/1 UNITS)
L2 (230/50/1 UNITS)
+7(812)987-08-81

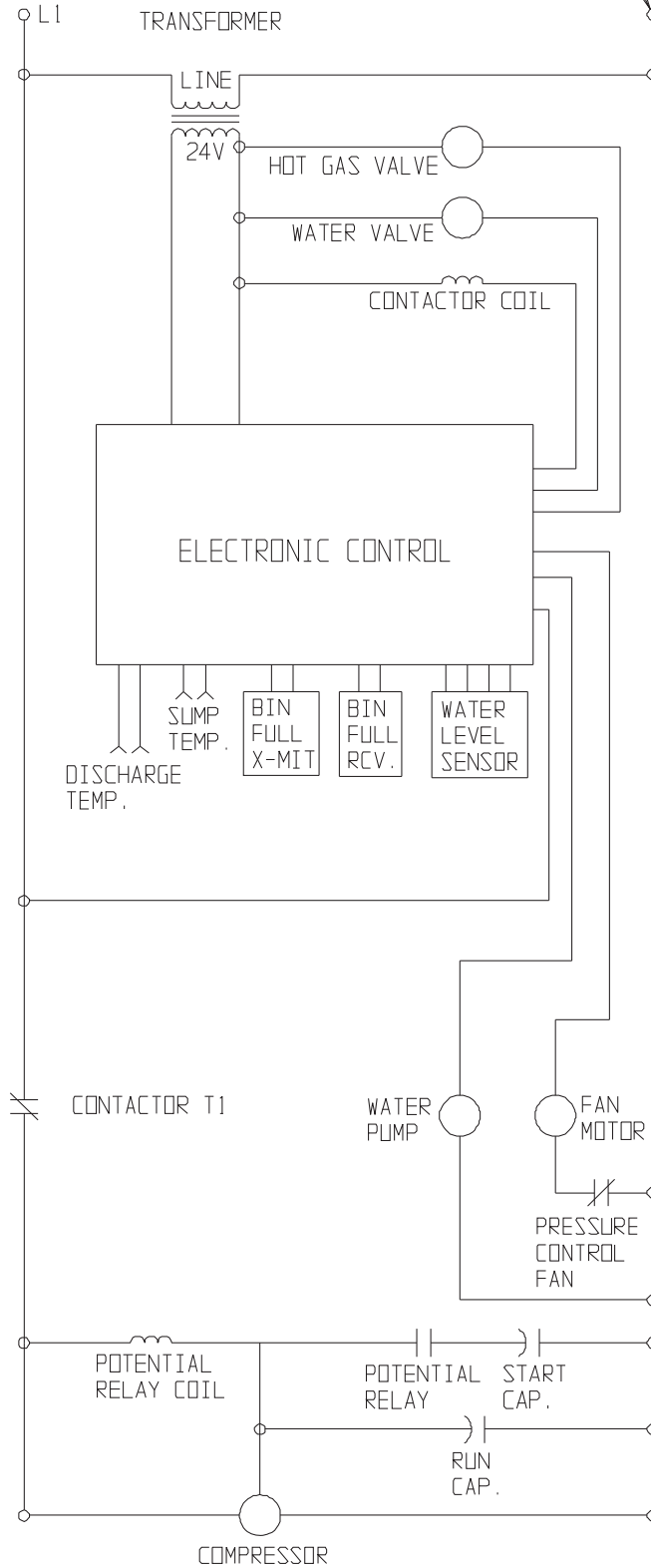

A - C Series CME256 and CME506 Air Cooled Wiring Diagram

+7(812)987-08-81

A36991-001

USE COPPER CONDUCTORS ONLY

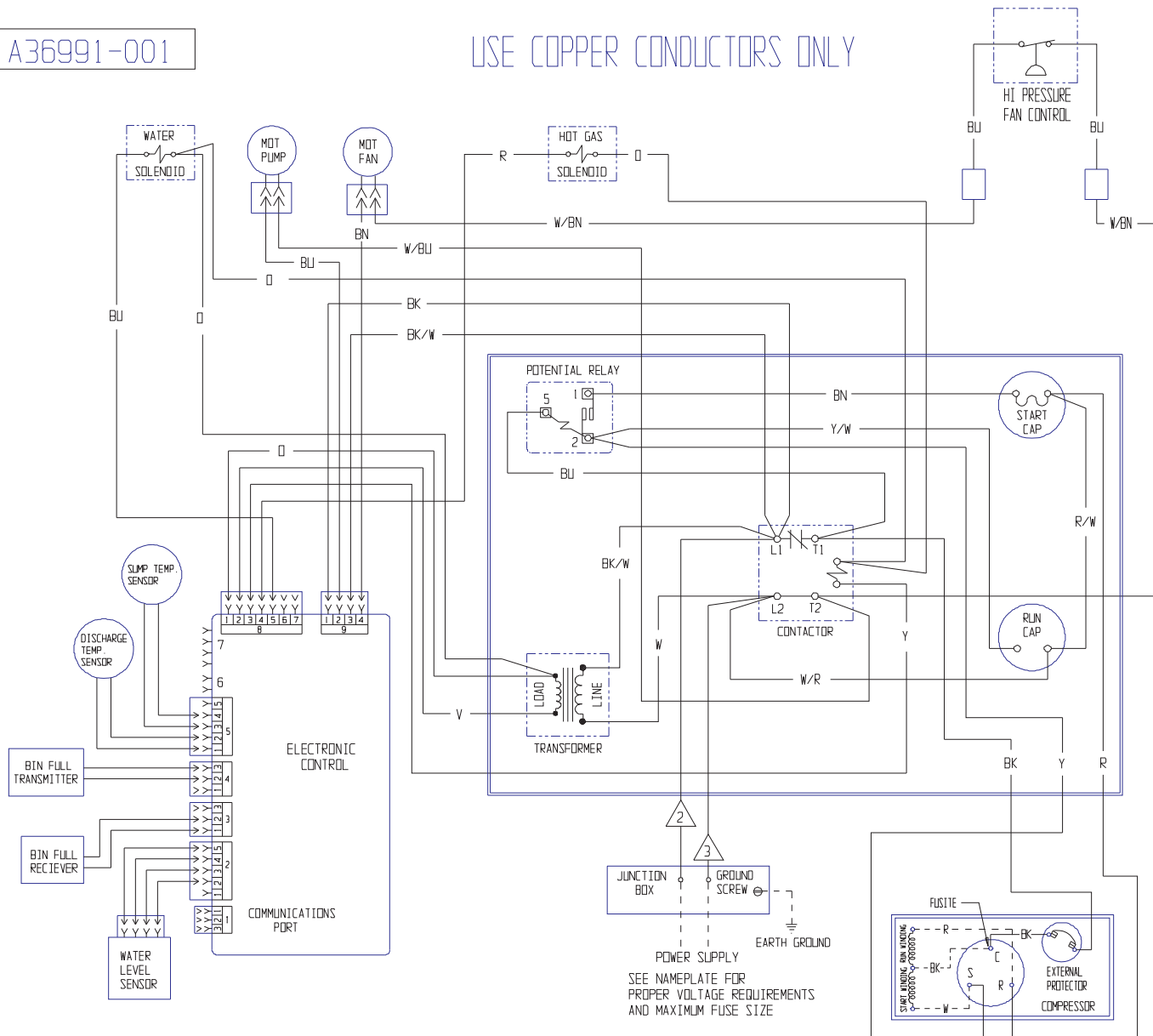

THIS UNIT MUST BE GROUNDED.

CAUTION:

MORE THAN ONE DISCONNECT MEANS MAY BE REQUIRED TO DISCONNECT ALL POWER TO THIS UNIT.

- ⚠ DASHED LINES INDICATE FIELD WIRING WHICH MUST BE INSTALLED IN ACCORDANCE WITH THE NATIONAL ELECTRICAL CODE AND ALL STATE AND LOCAL CODES.
- ⚠ WIRE COLOR FOR 115/60/1 UNITS: BLACK
WIRE COLOR FOR 230/50/1 UNITS : BROWN
- ⚠ WIRE COLOR FOR 115/60/1 UNITS: WHITE
WIRE COLOR FOR 230/50/1 UNITS : BROWN

A - C Series Water Cooled Single Phase Schematic Diagram

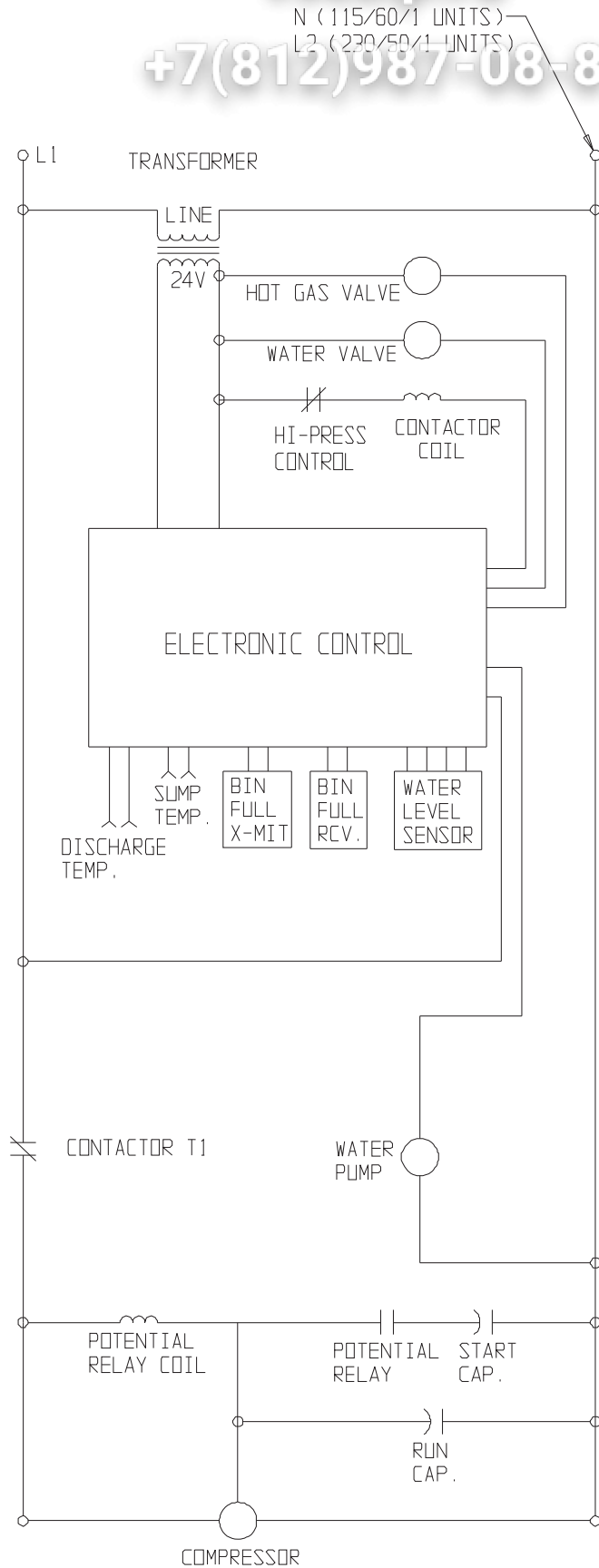

A - C Series CME256 and CME506 Water Cooled Wiring Diagram

+7(812)987-08-81

A36670-001

USE COPPER CONDUCTORS ONLY

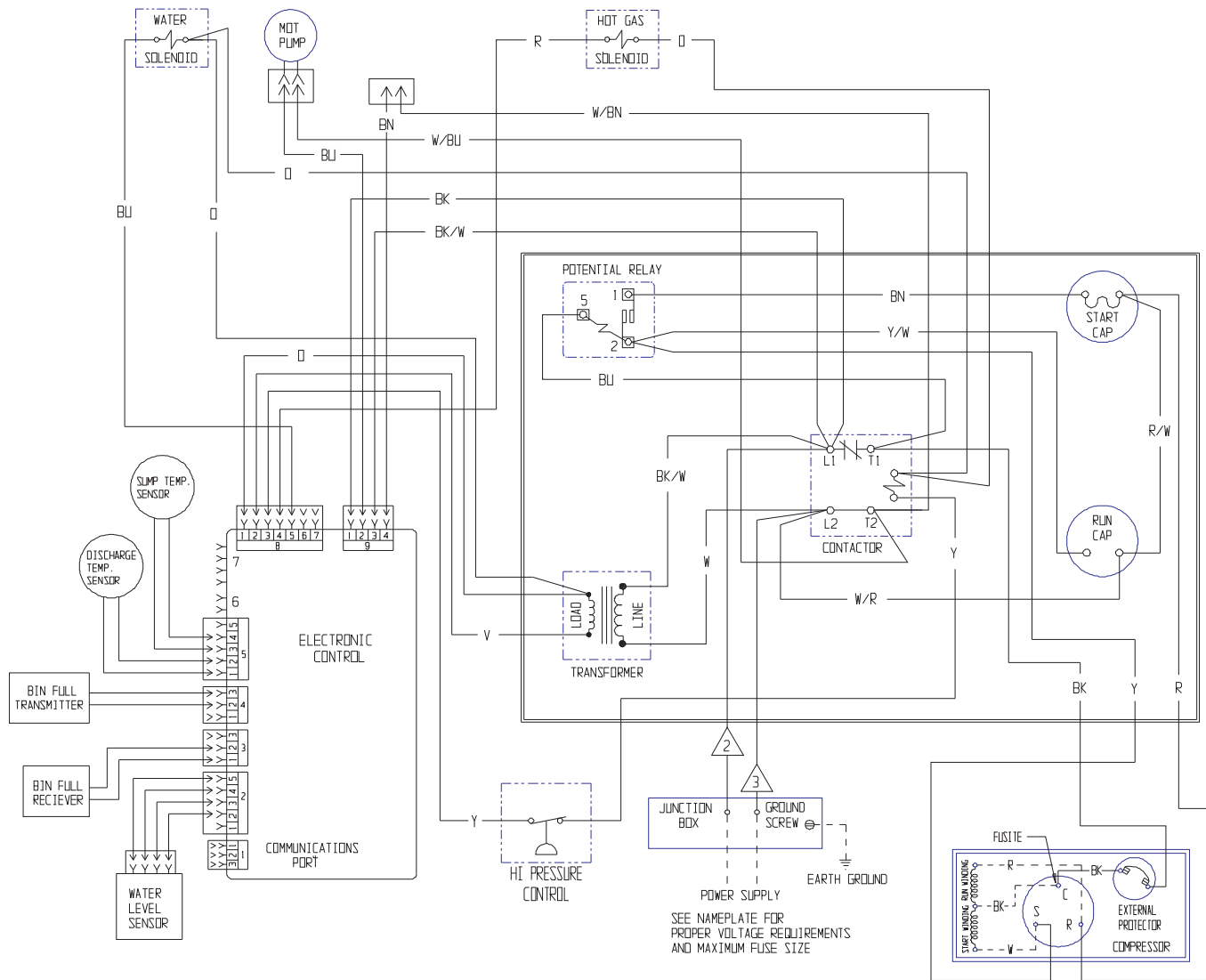

CAUTION: MORE THAN ONE DISCONNECT MEANS MAY BE REQUIRED TO DISCONNECT ALL POWER TO THIS UNIT.

THIS UNIT MUST BE GROUNDED.

A - H Series Three Phase Air Cooled Schematic Diagram

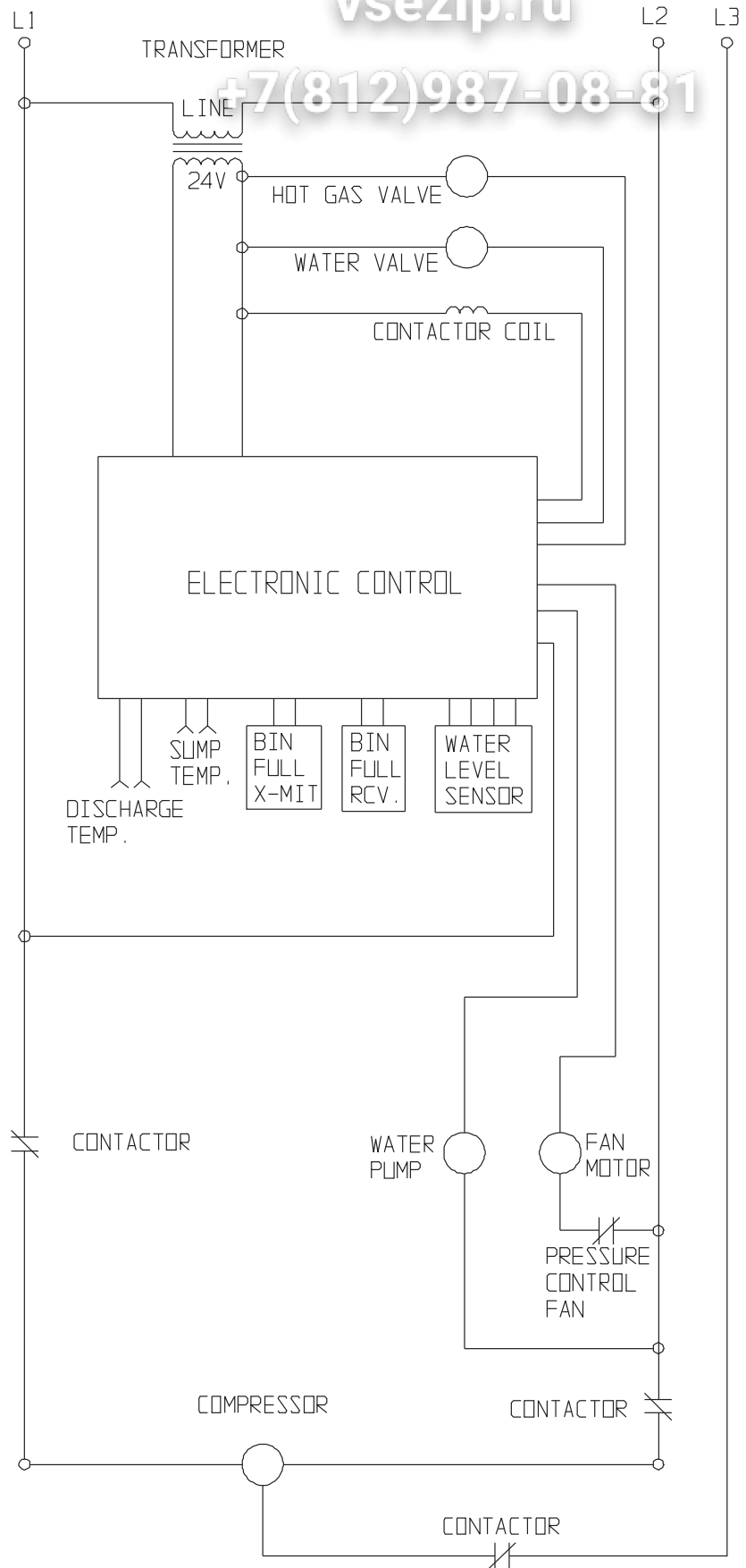

D thru H Series, 50 Hz CME256 Diagram

Зип Общенит
vsezip.ru

+7(812)987-08-8

△ DASHED LINES INDICATE FIELD WIRING WHICH MUST BE INSTALLED IN ACCORDANCE WITH THE NATIONAL ELECTRICAL CODE AND ALL STATE AND LOCAL CODES.

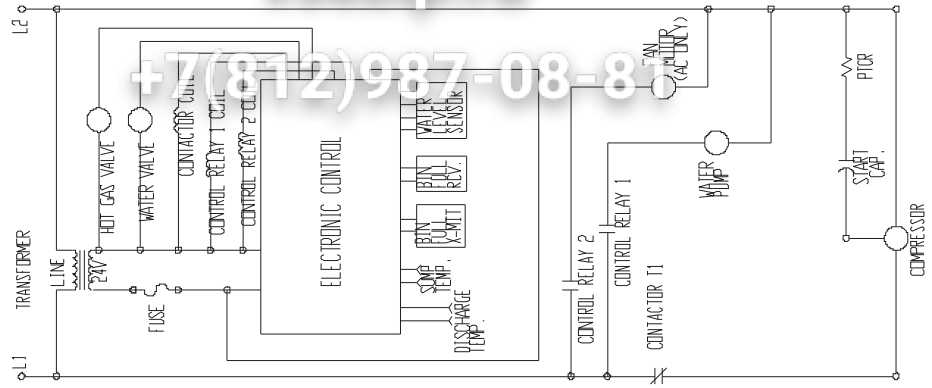

USE COPPER CONDUCTORS ONLY

CAUTION: PTCR WILL BE HOT IF COMPRESSOR MAY NOT START IF PTCR IS NOT ALLOWED TO COOL.

17-2816-01

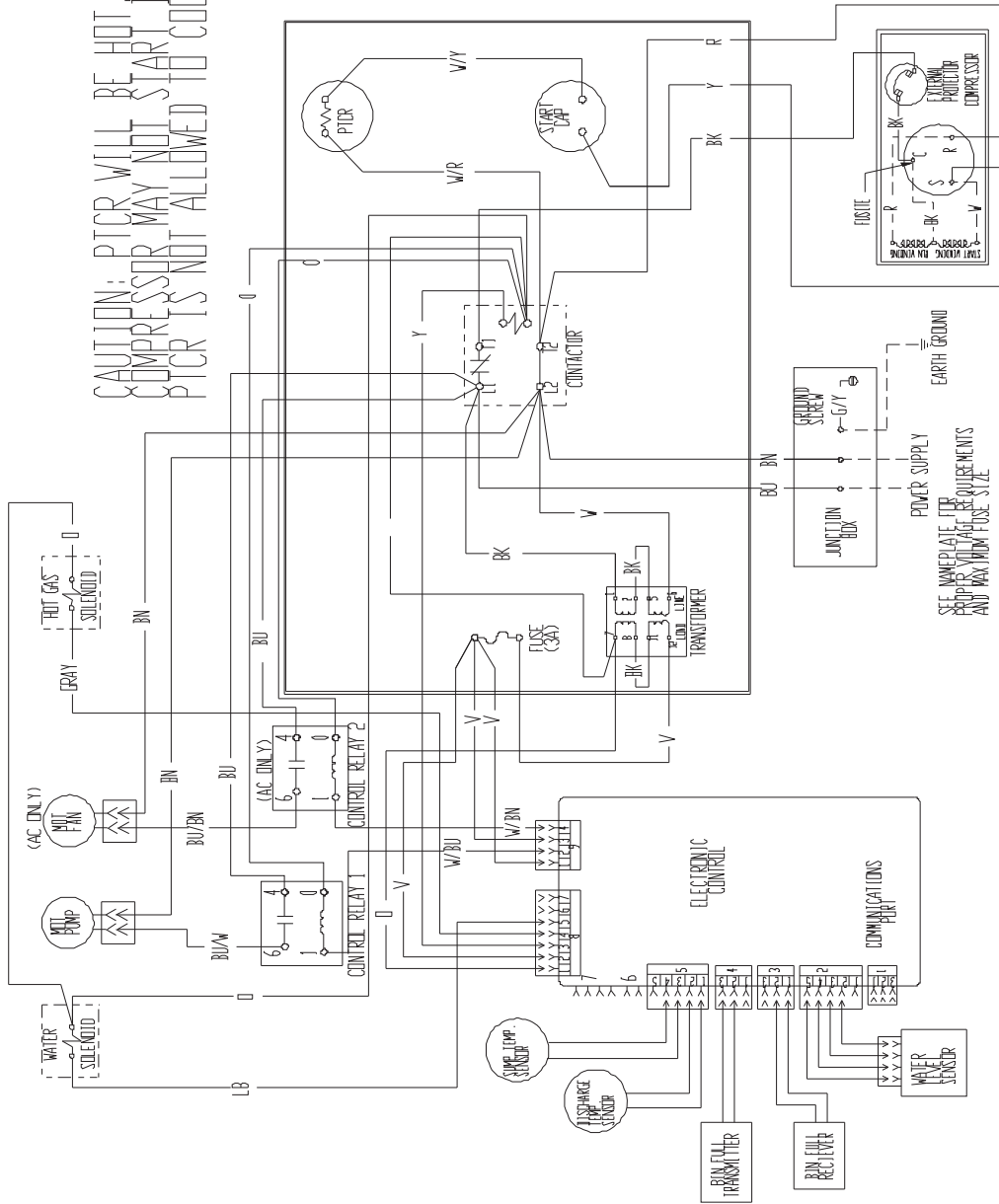

SEE NAMEPLATE FOR PROPER VOLTAGE REQUIREMENTS AND MAXIMUM FUSE SIZE

CAUTION: MORE THAN ONE DISCONNECT MEANS MAY BE REQUIRED TO DISCONNECT ALL POWER TO THIS UNIT.

THIS UNIT MUST BE GROUND.