

CM450E SERVICE PARTS

- This section contains the parts illustrations and parts lists for the CM450E.
- A "no number" designation, when found in the part number column, indicates the part in question is not available from Scotsman as an assembly. This designation is used only for clarity in making the list.
When ordering parts, to avoid costly delays and errors, give the part number, the complete description as shown in the list, and the quantity of each part or assembly required.

CM450's have been manufactured in "A", "C", "D" and "E" series (as in CM450AE32E). This parts list is for the model CM450 "E". Check the complete model number to see that it is an E model.

TABLE OF CONTENTS

Exterior Panels.....	2
Interior Panels.....	3
Air Cooled Refrigeration.....	4
Water Cooled Refrigeration	5
Water System	6
Control Box	7
Wiring Diagrams	8

CM450E SERVICE PARTS

CABINET ASSEMBLY

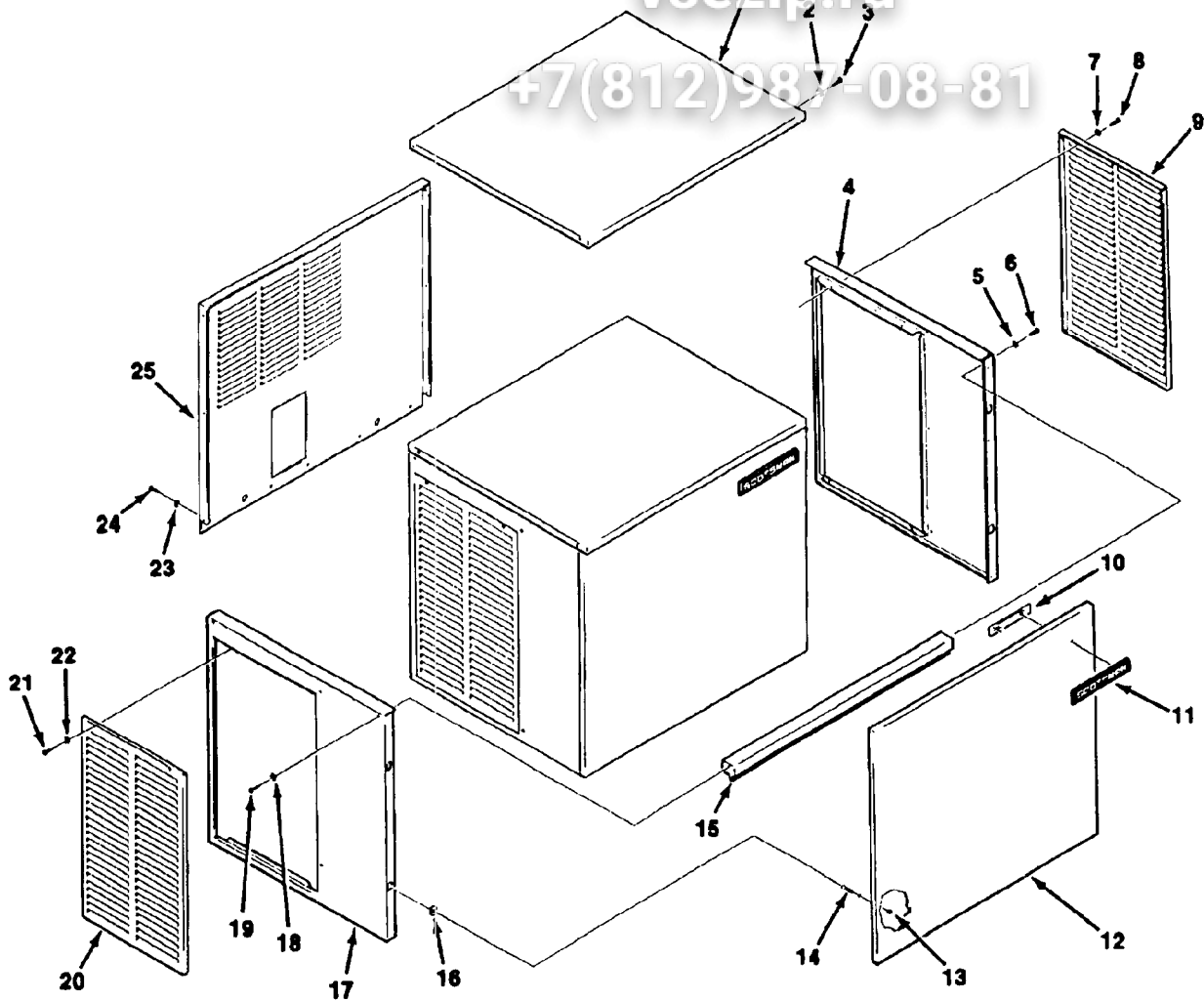

ITEM NUMBER	PART NUMBER	DESCRIPTION	ITEM NUMBER	PART NUMBER	DESCRIPTION
1	A32159-001	Top Panel, Painted	13	03-1406-04	Nut
	A32159-002	Top Panel, S. S.	14	15-0411-00	Strike
2	03-1417-03	Lockwasher	15	A32169-001	Front Support
3	03-1531-01	Screw	16	02-0836-00	Cabinet Catch
4	A32162-001	Right End Panel, Paint	17	A32163-001	Left End Panel, Paint
	A32162-002	Right End Panel, S.S.		A32163-002	Left End Panel, S.S.
5.	03-1417-03	Lockwasher	18	03-1417-03	Lockwasher
6	03-1531-01	Screw	19	03-1531-01	Screw
7	03-1417-03	Lockwasher	20	A32161-001	Service Panel, Paint
8	03-1404-12	Screw		A32161-002	Service Panel, S.S.
9	A32161-001	Service Panel, Painted	21	03-1404-12	Screw
	A32161-002	Service Panel, S.S.	22	03-1412-03	Lockwasher
10	03-0271-00	Speed Nut	23	03-1417-03	Lockwasher
11	15-0711-01	Emblem	24	03-1531-01	Screw
12	A32160-001	Front Panel, Painted	25	A32202-001	Back Panel
	A32160-002	Front Panel, S.S.			

CM450E SERVICE PARTS

CABINET INTERIOR

vsezip.ru

+7(812)987-08-81

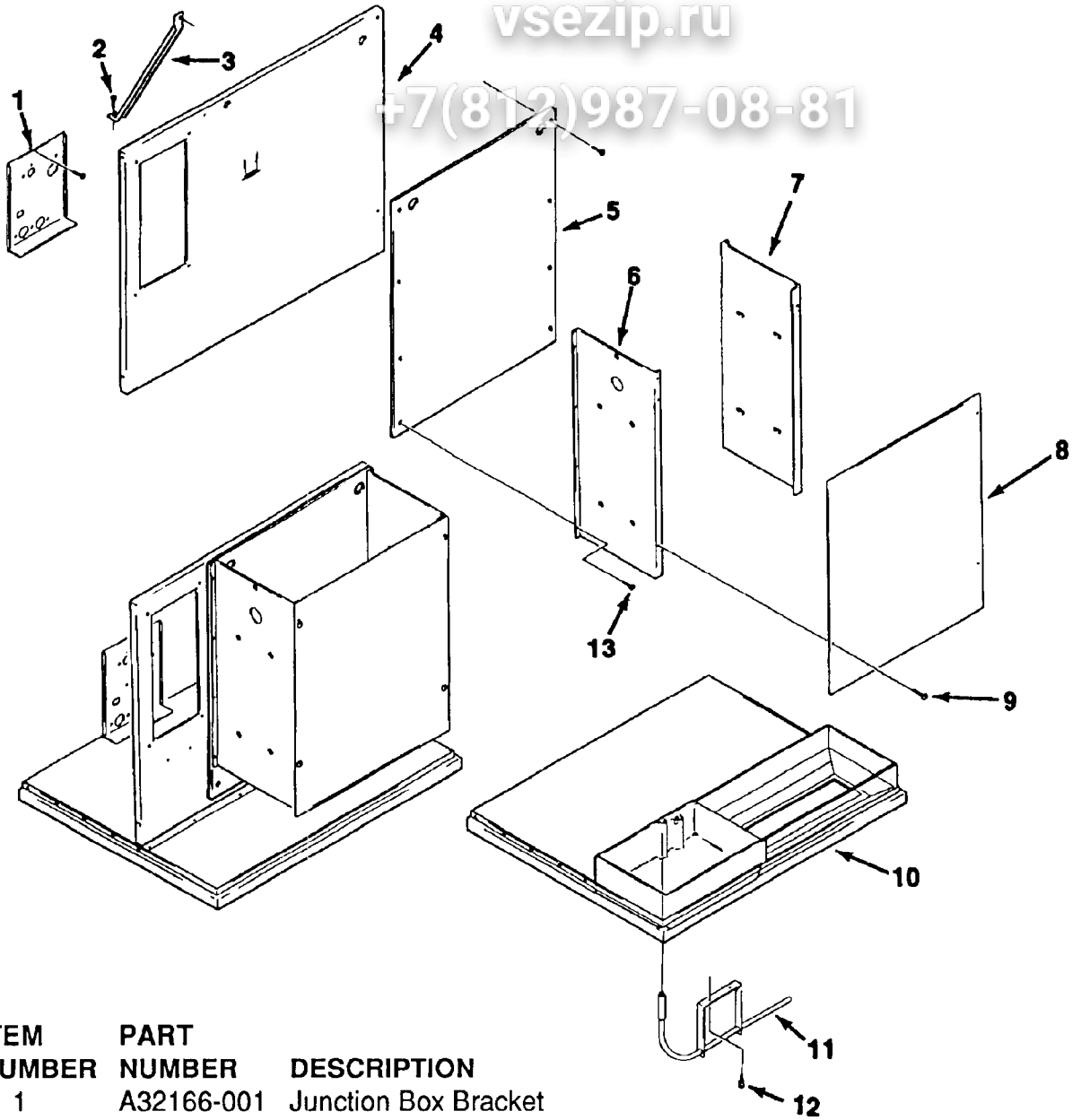

ITEM NUMBER	PART NUMBER	DESCRIPTION
1	A32166-001	Junction Box Bracket
2	03-1645-01	Screw
3	A32210-001	Support Brace
4	A32158-001	Retainer
5	02-2867-01	Splash Panel
6	A32172-001	Evaporator Bracket, Right
7	A32173-001	Evaporator Bracket, Left
8	A32165-001	Evaporator Plate Cover
9	03-0727-09	Thumbscrew
10	A32153-001	Base
11	A32262-001	Bin Thermostat Bracket
12	03-0727-09	Thumbscrew
13	03-1531-02	Screw

CM450E SERVICE PARTS LIST

AIR COOLED REFRIGERATION

vsezip.ru

+7(812)987-08 81

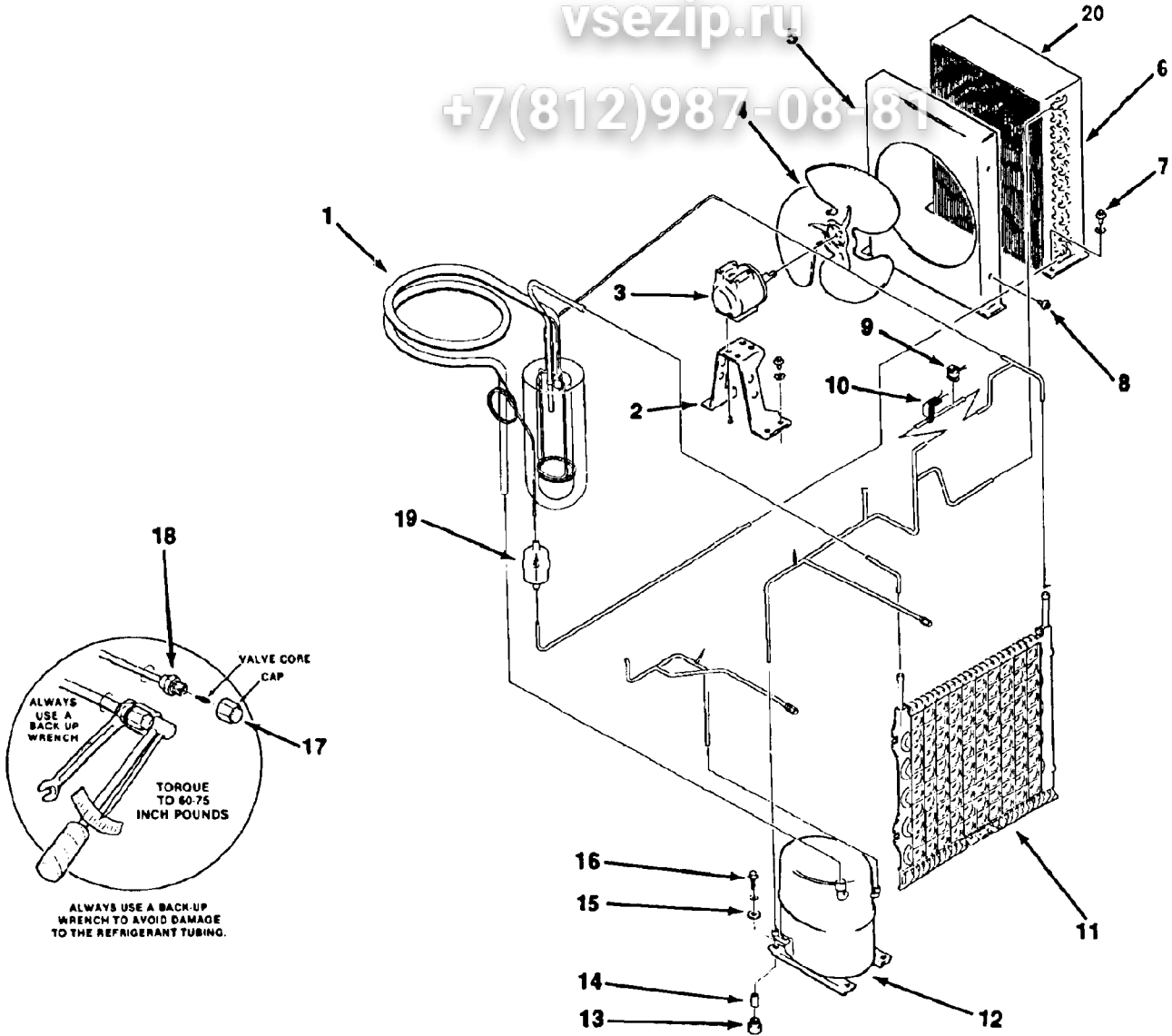

ITEM NUMBER	PART NUMBER	DESCRIPTION	ITEM NUMBER	PART NUMBER	DESCRIPTION
1	A32254-022	Heat Exchanger	12	18-8000-04	Compressor (203-230/60/1) (Has an internal overload)
2	18-3739-01	Fan Motor Bracker	13	18-6800-01	Grommet
3	18-5105-02	Fan Motor	14	18-2300-26	Sleeve
4	18-3732-01	Fan Blade	15	03-1407-07	Washer
5	A32171-001	Fan Shroud	16	03-1405-20	Screw
6	18-0398-01	Condenser	17	16-0563-00	Cap
7	03-1645-01	Screw	18	16-0560-00	Core
	03-1410-03	Lockwasher	19	02-2426-02	Drier
	03-1407-05	Washer	20	A32975-001	Foam Filter
8	03-1531-01	Screw			
9	12-2300-03	Hi Temp Cut Out			
10	12-2135-02	Hot Gas Valve			
11	A30296-020	Evaporator			

CM450E SERVICE PARTS

WATER COOLED REFRIGERATION

vsezip.ru

+7 812 987-08-81

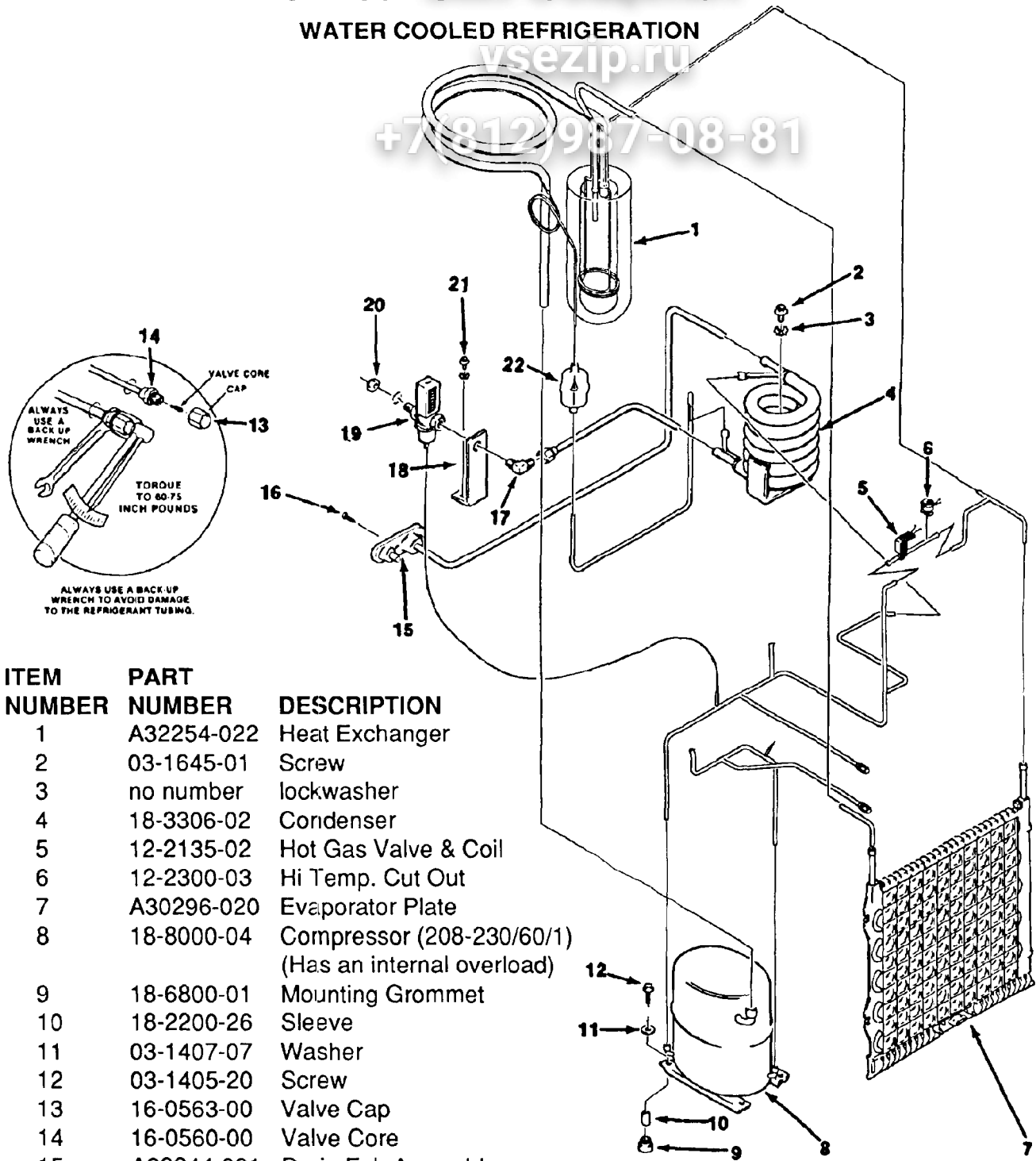

ITEM NUMBER	PART NUMBER	DESCRIPTION
1	A32254-022	Heat Exchanger
2	03-1645-01	Screw
3	no number	lockwasher
4	18-3306-02	Condenser
5	12-2135-02	Hot Gas Valve & Coil
6	12-2300-03	Hi Temp. Cut Out
7	A30296-020	Evaporator Plate
8	18-8000-04	Compressor (208-230/60/1) (Has an internal overload)
9	18-6800-01	Mounting Grommet
10	18-2200-26	Sleeve
11	03-1407-07	Washer
12	03-1405-20	Screw
13	16-0563-00	Valve Cap
14	16-0560-00	Valve Core
15	A32244-001	Drain Fab Assembly
16	03-1403-14	Screw
17	16-0401-02	Brass Elbow
18	no number	Bracket
19	11-0424-01	Water Reg. Valve
20	03-1394-01	Pal Nut
21	03-1403-14	Screw
22	02-2426-02	Filter Drier

CM450E SERVICE PARTS LIST

WATER SYSTEM

vsezip.ru

+7(812)987-0878

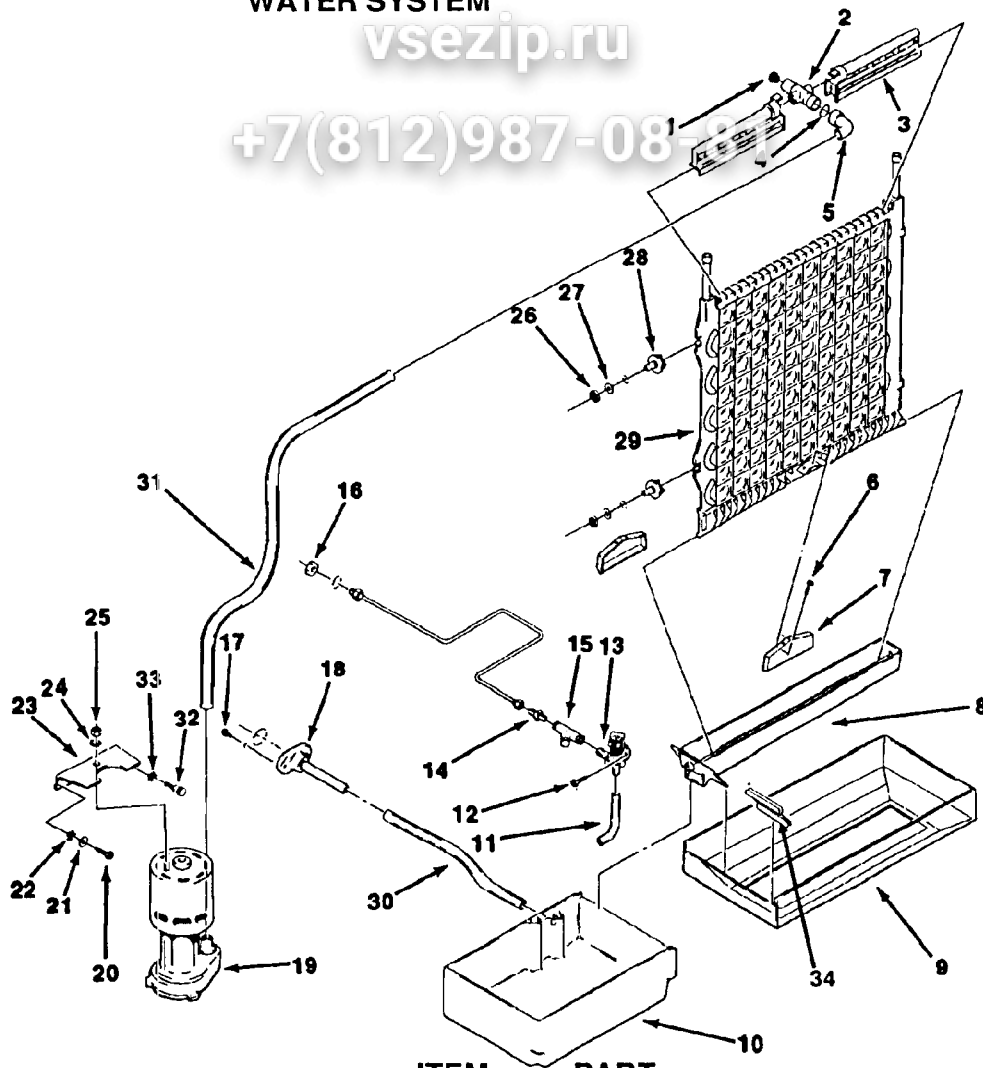

ITEM NUMBER	PART NUMBER	DESCRIPTION	ITEM NUMBER	PART NUMBER	DESCRIPTION
1	13-0840-01	Manifold Plug	18	A32282-003	Drain Ass. (Air Cooled)
2	A29703-001	Manifold Water Tube	19	12-2260-22	Water Pump Assembly
3	02-2527-01	Water Distrib. Tube	20	03-1403-17	Screw
4	13-0617-48	O-Ring (2)	21	03-1407-03	Washer
5	16-0671-01	Elbow	22	03-1408-31	Washer
6	03-1404-10	Screw	23	A30914-002	Pump Mounting Bracket
7	02-2878-01	Sump End Cover	24	03-1417-05	Lockwasher
8	02-2868-01	Drain Trough	25	03-1406-05	Nut
9	no number	Cube Chute	26	03-1394-03	Pal Nut
10	02-2869-01	Sump	27	03-1408-34	Special Washer
11	A30918-001	Sump Inlet Tube	28	02-2642-01	Plate Mount
12	03-1531-01	Screw	29	A30296-020	Evaporator
13	12-2313-02	Solenoid Valve	30	13-0674-07	Drain Hose, 8"
14	16-0791-01	Half Union	31	13-0674-07	Pump Hose, 33"
15	16-0162-00	Stainer	32	03-0727-09	Thumbscrew
16	03-1394-01	Pal Nut	33	03-1417-03	Lockwasher
17	03-1645-01	Screw	34	02-2875-01	Ice Deflector

CM450E SERVICE PARTS

CONTROL BOX

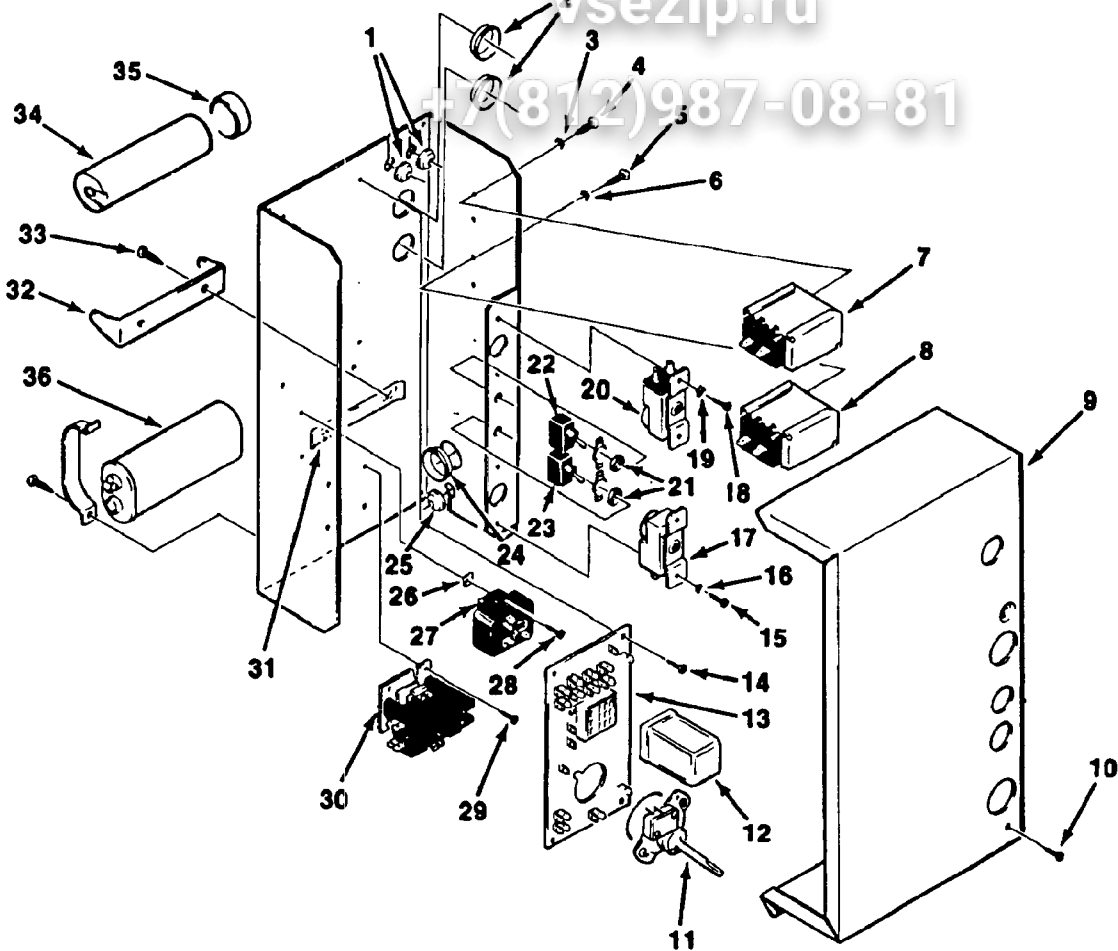

ITEM NUMBER	PART NUMBER	DESCRIPTION	ITEM NUMBER	PART NUMBER	DESCRIPTION
1	13-0557-00	Grommet	18	03-1403-05	Screw
2	12-1213-10	Snap Bushing	19	03-1417-03	Lockwasher
3	03-1417-18	Lockwasher	20	11-0428-01	Cube Size Control
4	03-1403-02	Screw	21	03-1417-16	Lockwasher
5	03-1403-02	Screw	22	12-0426-01	Switch
6	03-1417-18	Lockwasher	23	12-0426-01	Switch
7	11-0426-01	Fan Control	24	12-1213-17	Snap Bushing
8	11-0425-01	High Press. Safety -AC	25	13-0557-00	Grommet
	11-0410-02	High Press. Safety -WC	26	03-1423-01	Speed Nut
9	A32168-001	Control Box Cover	27	18-1903-46	Potential Relay
10	03-1531-01	Screw	28	03-1403-02	Screw
11	12-1980-02	Timer & Switch	29	03-1403-15	Screw
12	12-1879-03	Relay, 230V	30	12-2048-02	Contactor
13	12-1912-01	Circuit Board	31	03-1423-01	Twin Speed Nut
14	03-1403-02	Screw	32	18-2200-39	Start Capacitor Bracket
15	03-1403-05	Screw	33	03-1403-15	Screw
16	03-1417-03	Lockwasher	34	18-1901-48	Start Capacitor
17	11-0427-02	Bin Thermostat	35	18-4300-50	Start Capacitor Cap.
			36	18-1902-45	Run Capacitor

CM450E WIRING DIAGRAMS

Component Layout Diagram for CM450E-32E (208-230/60/1) Air or Water Cooled.
(Water Cooled has no Fan or Fan Control)

A34311-032

Caution: More than one disconnect means may be required to disconnect all power to this unit.

+7(812)987-08-31

COPPER CONDUCTORS ONLY

USE

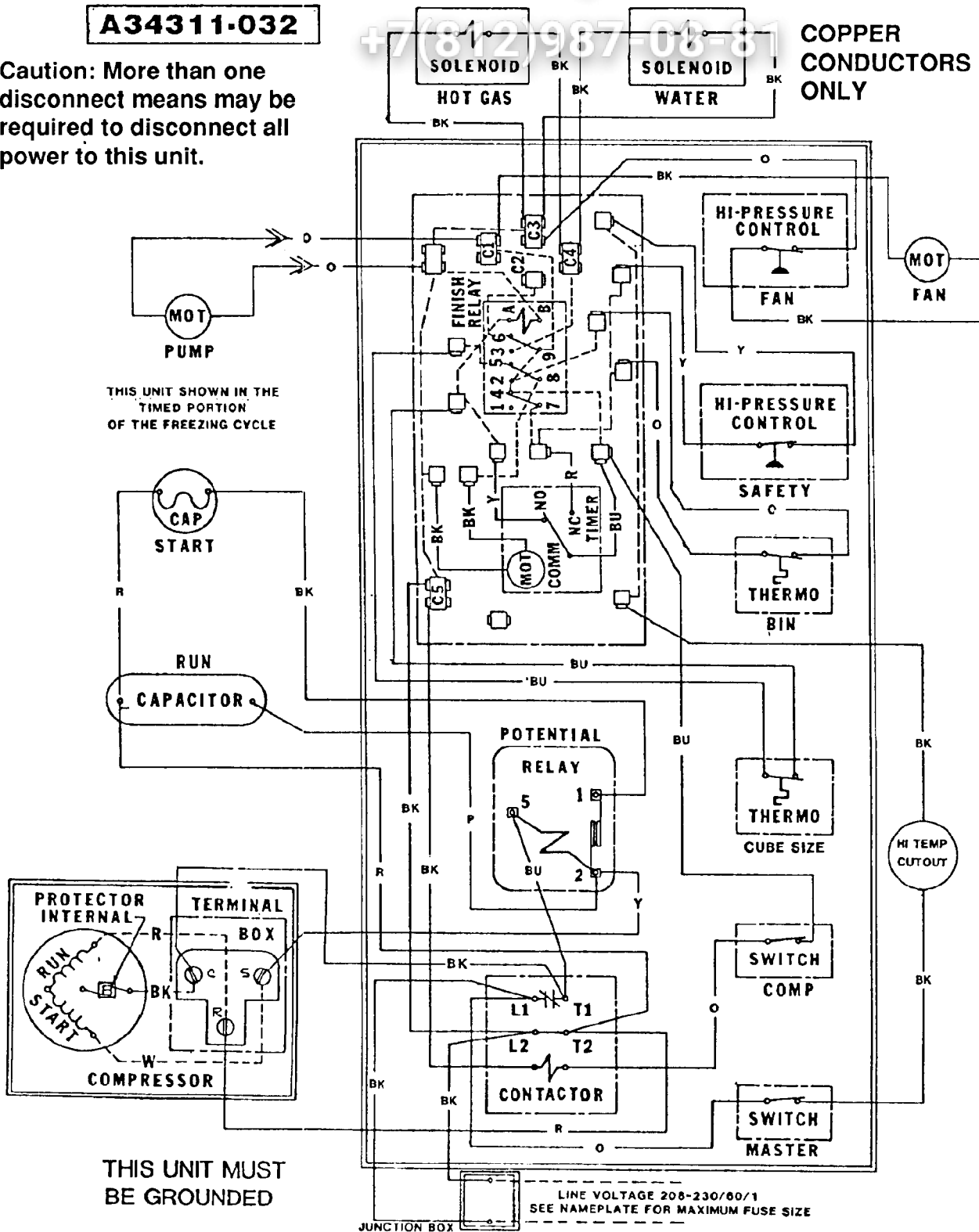

THIS UNIT SHOWN IN THE TIMED PORTION OF THE FREEZING CYCLE

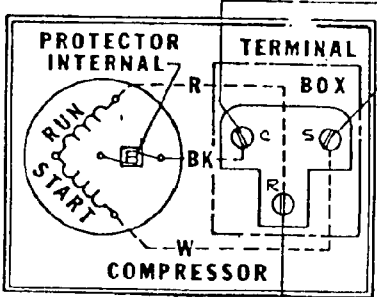
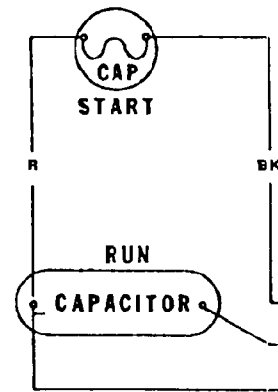

THIS UNIT MUST BE GROUNDED

LINE VOLTAGE 208-230/60/1
SEE NAMEPLATE FOR MAXIMUM FUSE SIZE

CM450E WIRING DIAGRAMS

Schematic Diagram for CM450E-32E (208-230/60/1) Air or Water Cooled.
(Water Cooled has no Fan Or Fan Control)

