

Зип Общепит

vsezip.ru DESPIECE TECNICO

+7(812)987-08-81

**Hornos Mixtos
Fours Mixtes
Combi Ovens
HeiBluftdämpfer
Forno Misti**

Modelos:

**HMM-6/11
HMM-10/11
HMM-10/21
HMM-2-10/11**

**MFHMM-6/11
MFHMM-10/11
MFHMM-10/21**

**HMM-6/11 UL
HMM-10/11 UL
HMM-10/21 UL**

**VECM-6/11
VECM-10/11
VECM-10/21
VECM-2-10/11**

Noviembre 2003 November

FAGOR 

Fagor Industrial

Зип Общепит

vsezip.ru

+7(812)987-08-81

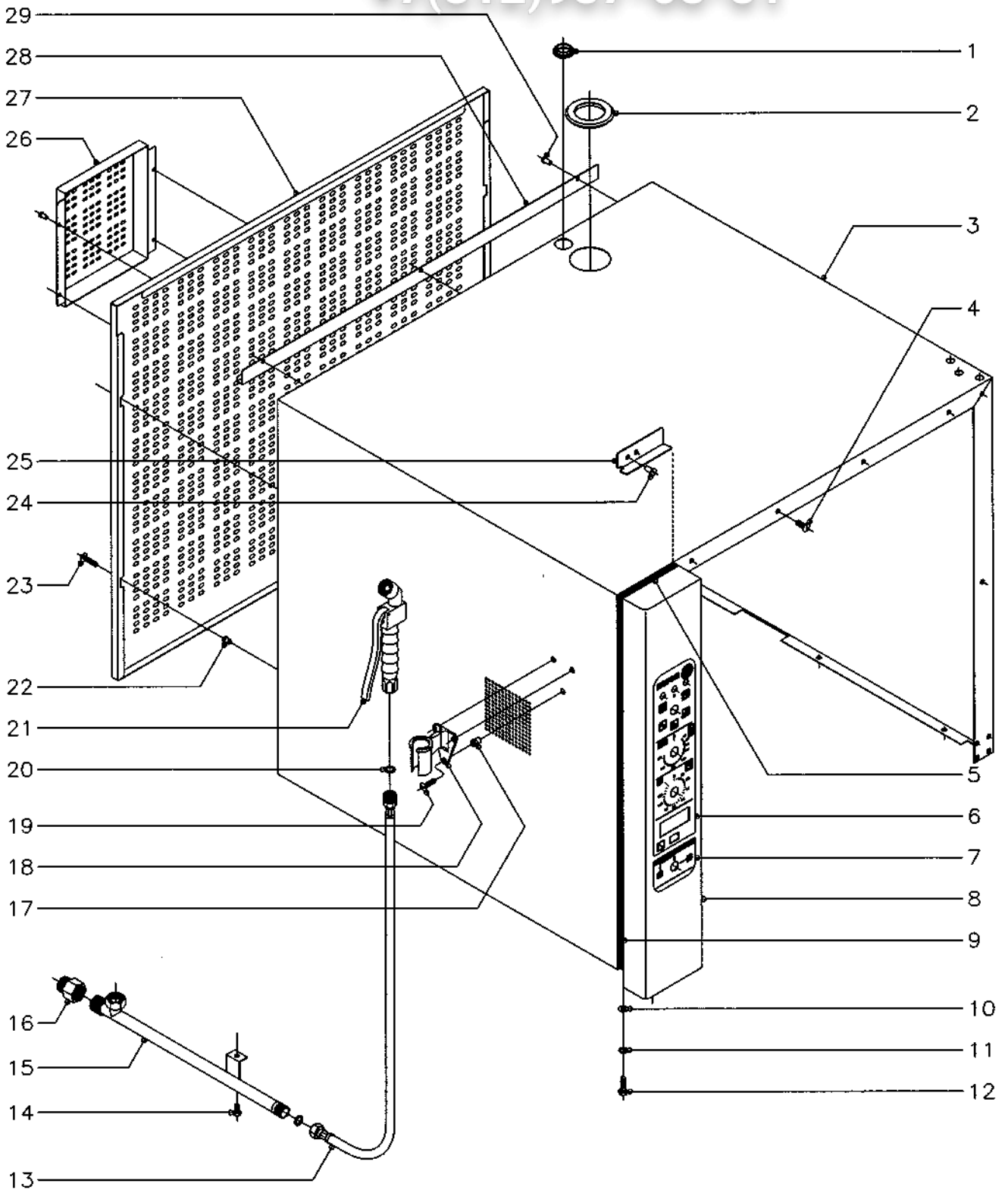

N plano
C-1443

Firma
[Signature]

Fecha
11-2003

Aparato
HORNOS MIX. ELECTROMECHANICOS

MUEBLE

Lamina
1

Fagor Industrial S.Coop. **FAGOR**
Orate

MOD.	HORNOS MIXTOS ELECTROMECANICOS	ZONA	MUEBLE					
ITEM	CODIGO	DENOMINACION	TEXTO	HMM-6/11	HMM-10/11	HMM-10/21	HMM-2-10/11	HMM-6/11 UL
1	N503017	Soporte termostato		1	1	1	1	1
2	R662813	Pasamuros chimenea		1	1	1	1	1
3	R662819	Cuerpo exterior de horno 6/11		1	-	-	-	1
3	R672816	Cuerpo exterior de horno 10/11		-	1	-	-	-
3	R682812	Cuerpo exterior de horno 10/21		-	-	1	1	-
4	Q152017	Tornillo amarre M-6x13		6	6	6	6	6
5	3715400	Junta panel portamandos L=130		1	1	1	1	1
6	R743012	Serigrafia superior (FAGOR)		1	1	1	1	-
6	R743070	Serigrafia superior (FAGOR - UL)		-	-	-	-	1
6	R743020	Serigrafia superior (MF)		-	-	-	-	1
7	R663014	Serigrafia inferior (FAGOR)		1	-	-	-	1
7	R693000	Serigrafia inferior (FAGOR)		-	1	1	1	-
7	R693057	Serigrafia inferior (MF)		-	-	-	-	1
7	R693031	Serigrafia inferior (MF)		-	-	-	-	-
8	R742807	Panel portamandos 6/11		1	-	-	-	1
8	R752805	Panel portamandos 10/11 y 10/21		-	1	1	1	-
9	3715400	Junta panel portamandos L=530		2	-	-	-	2
9	3715400	Junta panel portamandos L=770		-	2	2	2	-
10	Q232040	Arandela plana A-6		2	2	2	2	2
11	Q262040	Arandela muelle A-6		2	2	2	2	2
12	Q012042	Tornillo exagonal M-6x15		2	2	2	2	2
13	R095006	Flexible de ducha		*	*	*	*	1
14	Q012042	Tornillo exagonal M-6x15		*	*	*	*	1
15	R675002	Suplemento ducha		*	*	-	-	1
15	R685003	Suplemento ducha		-	-	*	*	-
16	T125033	Adaptador a rosca UL		-	-	-	-	1
17	Q221342	Remache exagonal M-4		*	*	*	*	3
18	R095007	Soporte de ducha		*	*	*	*	1
19	Q042022	Tornillo avellanado M-4x15		*	*	*	*	3

Зип Общепит

vsezip.ru

+7(812)987-08-81

N plano C-1444
Firma
Fecha 11-2003
Aparato HORNOS MIX. ELECTROMECANICOS
Laminha 2
Fagor Industrial S. Coop. Oporto

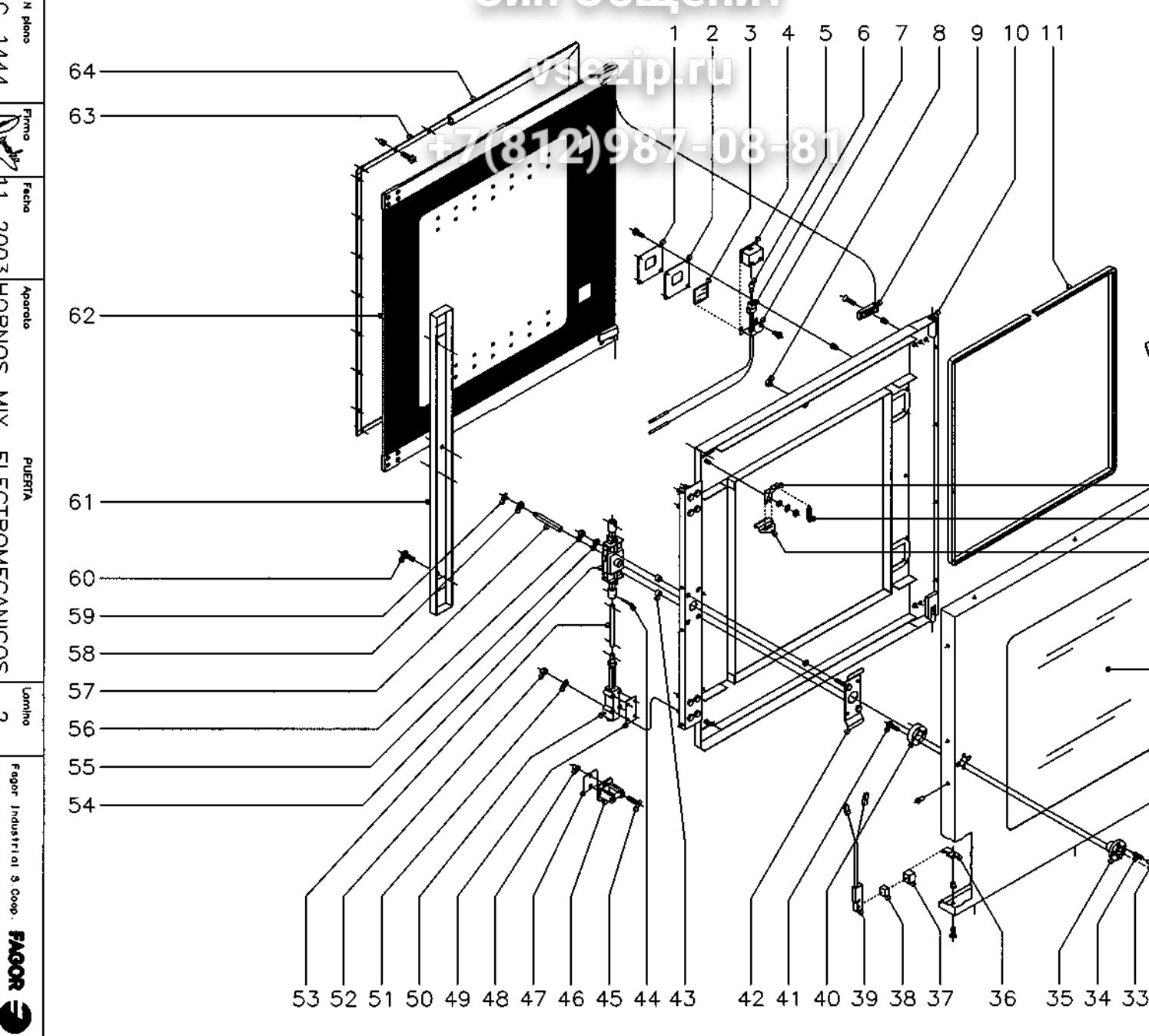

MOD.	HORNOS MIXTOS ELECTROMECHANICOS	ZONA	PUERTA					
ITEM	CODIGO	DENOMINACION	TEXTO	HMM-6/11	HMM-10/11	HMM-10/21	HMM-2-10/11	HMM-6/11 UL
	1100002594	KIT Puerta completa 6/11		1	-	-	-	1
	1100002595	KIT Puerta completa 10/11		-	1	-	-	-
	1100002596	KIT Puerta completa 10/21		-	-	1	1	-
1	R670608	Tapa cierre lampara		2	2	2	2	2
	Q152004	Tornillo aplastado M-5x13		8	8	8	8	8
	Q222011	Remache exagonal M-5		8	8	8	8	8
2	R670609	Junta cierre lampara		2	2	2	2	2
3	R670618	Cristal de lampara		2	2	2	2	2
4	R670610	Deflector de lampara		2	2	2	2	2
5	R663013	Lampara 10 W. 12 V.		2	2	2	2	2
6	R663058	Portalamparas		2	2	2	2	2
7	R670611	Suplemento deflector		2	2	2	2	2
	Q042031	Tornillo avellanado M-5x10		4	4	4	4	4
8	R670617	Tope cristal interior		6	6	6	6	6
9	R670615	Base de bisagra		2	2	2	2	2
	Q042032	Tornillo avellanado M-5x15		2	2	2	2	2
	Q222011	Remache exagonal M-5		2	2	2	2	2
10	T080500	Contrapuerta completa 6/11		1	-	-	-	1
10	T110500	Contrapuerta completa 10/11		-	1	-	-	-
10	T120500	Contrapuerta completa 10/21		-	-	1	1	-
11	3715200	Junta cristal L=1700		1	-	-	-	1
11	3715200	Junta cristal L=2000		-	1	-	-	-
11	3715200	Junta cristal L=2300		-	-	1	1	-
12	Q212051	Tuerca sombrerete M-8		3	3	3	3	3
13	Q242050	Arandela abanico A-8		3	3	3	3	3
14	Q302025	Arandela plana Ø8,4xØ20x1,5		3	3	3	3	3
15	Q012042	Tornillo exagonal M-6x15		1	1	1	1	1
16	Q242040	Arandela abanico A-6		1	1	1	1	1

MOD.		HORNOS MIXTOS ELECTROMECANICOS		ZONA	PUERTA				
ITEM	CODIGO	DENOMINACION	TEXTO	HMM-6/11	HMM-10/11	HMM-10/21	HMM-2-10/11	HMM-6/11 UL	
17	R662807	Arandela amarre puerta		1	1	1	1	1	
18	T130500	Bisagra superior		1	1	1	1	1	
19	R660534	Eje superior		1	1	1	1	1	
20	Z850519	Resorte		1	1	1	1	1	
21	R670612	Base de pestillo		2	2	2	2	2	
	Q302022	Arandela plana Ø16xØ6x1,2		2	2	2	2	2	
	Q242040	Arandela abanico A-6		2	2	2	2	2	
	Q162040	Tuerca exagonal M-6		2	2	2	2	2	
22	R660605	Muelle tensor pestillo		2	2	2	2	2	
23	R670613	Pestillo sujecion cristal interior		2	2	2	2	2	
24	R660600	Panel puerta 6/11		1	-	-	-	1	
24	R670600	Panel puerta 10/11		-	1	-	-	-	
24	R680600	Panel puerta 10/21		-	-	1	1	-	
	Q412002	Remache tubular Ø4x7,5		14	14	14	14	14	
25	R660606	Cristal exterior 6/11		1	-	-	-	1	
25	R670625	Cristal exterior 10/11		-	1	-	-	-	
25	R680609	Cristal exterior 10/21		-	-	1	1	-	
26	R660549	Guia eje inferior		1	1	1	1	1	
27	Q062040	Tornillo avellanado M-6x16		4	4	4	4	4	
28	R660551	Bisagra inferior		1	1	1	1	1	
29	Q242040	Arandela abanico A-6		2	2	2	2	2	
30	Q012041	Tornillo exagonal M-6x10		2	2	2	2	2	
31	T130502	Manilla		1	1	1	1	1	
32	Q132042	Varilla roscada M-6x15		1	1	1	1	1	
33	T130507	Piton enganche		2	2	2	2	2	
34	T130506	Resorte		2	2	2	2	2	
35	T130515	Guia manilla		1	1	1	1	1	
36	T130513	Soporte iman		1	1	1	1	1	
37	Z200507	Protector iman		1	1	1	1	1	

MOD.		HORNOS MIXTOS ELECTROMECAÑICOS		ZONA	PUERTA				
ITEM	CODIGO	DENOMINACION	TEXTO	HMM-6/11	HMM-10/11	HMM-10/21	HMM-2-10/11	HMM-6/11 UL	
38	Z200506	Iman		1	1	1	1	1	
39	Z100522	Interruptor magnetico		1	1	1	1	1	
40	T130514	Soporte resortes		1	1	1	1	1	
41	Q032032	Tornillo alomado M-5x15		2	2	2	2	2	
42	T130511	Suplemento fijacion cerradura		1	1	1	1	1	
43	Z608410	Casquillo		2	2	2	2	2	
44	Q352001	Pasador de aletas Ø2x15		4	4	4	4	4	
45	Q042043	Tornillo avellanado M-6x20		4	4	4	4	4	
46	R260545	Enganche		2	2	2	2	2	
47	R660538	Calzo de enganche		4	4	4	4	4	
48	Q221343	Remache exagonal M-6		4	4	4	4	4	
49	T080503	Suplemento elemento cierre		6	6	6	6	6	
50	T080504	Elemento de cierre		2	2	2	2	2	
51	Q262040	Arandela muelle A-6		8	8	8	8	8	
52	Q162040	Tuerca exagonal M-6		8	8	8	8	8	
53	R020502	Tubo alargadera		-	2	2	2	-	
54	T130509	Mecanismo de cierre		1	1	1	1	1	
55	Q262040	Arandela muelle A-6		2	2	2	2	2	
56	Q162040	Tuerca exagonal M-6		2	2	2	2	2	
57	T130508	Eje de manilla		1	1	1	1	1	
58	T130505	Casquillo		1	1	1	1	1	
59	Q271033	Arandela de seguridad Ø6		1	1	1	1	1	
60	Q032031	Tornillo alomado M-5x10		2	2	2	2	2	
60	Q032021	Tornillo alomado M-4x10		2	2	2	2	2	
61	T080502	Tapa cierre puerta		1	-	-	-	1	
61	T110502	Tapa cierre puerta		-	1	1	1	-	
62	1100002806	KIT Cristal interior completo 6/11		1	-	-	-	1	
62	1100002807	KIT Cristal interior completo 10/11		-	1	-	-	-	
62	1100002808	KIT Cristal interior completo 10/21		-	-	1	1	-	

Зип Общепит

vsezip.ru

77081298708-81

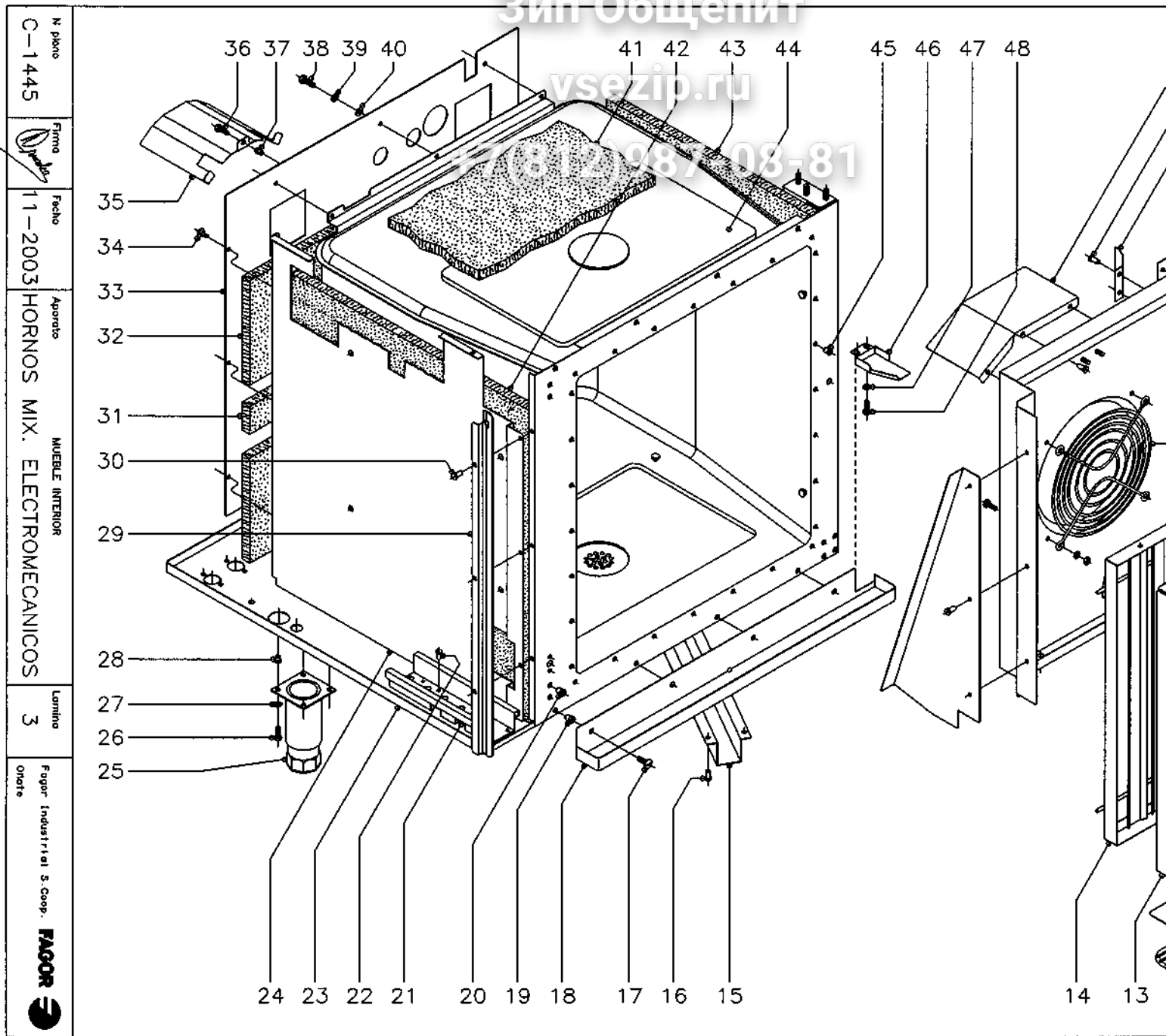

N plano
C-1445

Firma

Fecha
11-2003

Aparto
HORNO MIX. ELECTROMECANICOS

Laminas
3

Fagor Industrial S. Coop.
Onate

MUEBLE INTERIOR

MOD.		HORNOS MIXTOS ELECTROMECANICOS		ZONA	MUEBLE INTERIOR				
ITEM	CODIGO	DENOMINACION	TEXTO	HMM-6/11	HMM-10/11	HMM-10/21	HMM-2-10/11	HMM-6/11 UL	
1	R682632	Deflector de turbina		-	-	2	2	-	
	Q412002	Remache tubular Ø 4x7,5		-	-	6	6	-	
2	Q412002	Remache tubular Ø 4x7,5		4	4	4	4	4	
3	R292647	Escuadra sujecion cubreventilador		2	2	2	2	2	
4	R662648	Aleron derecho		1	-	-	-	1	
s/n	R662647	Aleron izquierdo		1	-	-	-	1	
	Q412002	Remache tubular Ø 4x7,5		6	-	-	-	6	
5	R662656	Cubre ventilador		1	-	-	-	1	
5	R672651	Cubre ventilador		-	1	-	-	-	
5	R682669	Cubre ventilador		-	-	1	1	-	
6	R732619	Aleron lateral		-	-	2	2	-	
7	Q412002	Remache tubular Ø 4x7,5		-	-	6	6	-	
8	R662661	Proteccion de turbina		-	-	-	-	1	
	Q032021	Tomillo alomado M-4x10		-	-	-	-	4	
	Q242020	Arandela abanico A-4		-	-	-	-	4	
	Q162020	Tuerca exagonal M-4		-	-	-	-	4	
9	Q412002	Remache tubular Ø 4x7,5		6	6	6	6	6	
10	R662668	Guia de bandejas derecha		1	-	-	-	1	
s/n	R662670	Guia de bandejas izquierda		1	-	-	-	1	
10	T112615	Guia de bandejas derecha		-	1	-	-	-	
s/n	T112617	Guia de bandejas izquierda		-	1	-	-	-	
10	T122614	Guia de bandejas derecha		-	-	1	-	-	
s/n	T122616	Guia de bandejas izquierda		-	-	1	-	-	
10	R682640	Guia de bandejas MARKET-FORGE		-	-	-	-	-	
11	R252816	Bandeja 1/1 (530x325x20)		1	1	-	1	-	
11	R032605	Bandeja 2/1 (530x650x40)		-	-	1	-	-	
12	R672665	Parrilla 1/1		1	1	-	1	3	
12	R682676	Parrilla 2/1		-	-	1	-	-	
12	R682641	Parrilla 2/1 MARKET-FORGE		-	-	-	-	-	

MOD.		HORNOS MIXTOS ELECTROMECANICOS		ZONA	MUEBLE INTERIOR				
ITEM	CODIGO	DENOMINACION	TEXTO	HMM-6/11	HMM-10/11	HMM-10/21	HMM-2-10/11	HMM-6/11 UL	
13	R662617	Anterior de filtro		1	-	-	-	1	
13	R092618	Anterior de filtro		-	1	1	1	-	
14	R662622	Posterior de filtro		1	-	-	-	1	
14	R092621	Posterior de filtro		-	1	1	1	-	
15	R672804	Cubre desagüe		1	1	-	-	1	
15	R682805	Cubre desagüe		-	-	1	1	-	
16	Q412002	Remache tubular Ø 4x7,5		8	8	8	8	8	
17	Q152017	Tornillo amarre M-6x13		4	4	4	4	4	
18	T112813	Recoge aguas		1	1	-	-	1	
18	T122811	Recoge aguas		-	-	1	1	-	
19	Q221343	Remache exagonal M-6		4	4	4	4	4	
20	Q221343	Remache exagonal M-6		8	8	8	8	8	
21	R342821	Guía del cuadro electrico		1	1	1	1	1	
22	Q412002	Remache tubular Ø 4x7,5		8	8	8	8	8	
23	R672813	Base exterior de horno		1	1	-	-	1	
23	R682811	Base exterior de horno		-	-	1	1	-	
24	T072614	Soporte lateral aislante		1	-	-	-	1	
24	T112624	Soporte lateral aislante		-	1	-	-	-	
24	T122619	Soporte lateral aislante		-	-	1	1	-	
25	X260151	Pata regulable		4	4	4	4	4	
26	Q012042	Tornillo exagonal M-6x15		16	16	16	16	16	
27	Q242040	Arandela abanico A-6		16	16	16	16	16	
28	Q221343	Remache exagonal M-6		16	16	16	16	16	
29	R662682	Protector portamandos		1	-	-	-	1	
29	R672674	Protector portamandos		-	1	1	1	-	
30	Q412002	Remache tubular Ø 4x7,5		3	3	3	3	3	
31	R662616	Aislante posterior 560x60x20		3	3	4	4	3	
32	R662615	Aislante posterior 800x110x20		2	-	-	-	2	
32	R672631	Aislante posterior 670x230x20		-	2	2	2	-	

MOD.		HORNOS MIXTOS ELECTROMECAÑICOS		ZONA		MUEBLE INTERIOR		
				+7(812)987-08-81				
ITEM	CODIGO	DENOMINACION	TEXTO	HMM-6/11	HMM-10/11	HMM-10/21	HMM-2-10/11	HMM-6/11 UL
33	R662655	Soporte aislante posterior		1	-	-	-	1
33	R672608	Soporte aislante posterior		-	1	-	-	-
33	R682606	Soporte aislante posterior		-	-	1	1	-
34	Q151301	Tornillo alomado		3	3	3	3	3
35	R142628	Tejadillo motor turbina		1	1	1	1	1
36	Q012042	Tornillo exagonal M-6x15		1	1	1	1	1
37	Q221343	Remache exagonal M-6		1	1	1	1	1
38	Q012042	Tornillo exagonal M-6x15		12	12	12	12	12
39	Q262040	Arandela muelle A-6		12	12	12	12	12
40	Q232040	Arandela plana A-6		12	12	12	12	12
41	R662614	Aislante base y techo 650x650x20		5	5	-	-	5
41	R682623	Aislante base y techo 860x790x20		-	-	5	5	-
42	R662613	Aislante lateral 650x530x20		3	-	-	-	3
42	R672630	Aislante lateral 770x650x20		-	3	-	-	-
42	R682623	Aislante lateral 860x790x20		-	-	3	3	-
43	R662613	Aislante lateral 650x530x20		2	-	-	-	2
43	R672630	Aislante lateral 770x650x20		-	2	-	-	-
43	R682623	Aislante lateral 860x790x20		-	-	2	2	-
44	R662681	Cuerpo interior horno		1	-	-	-	1
44	R672673	Cuerpo interior horno		-	1	-	-	-
44	R682674	Cuerpo interior horno		-	-	1	1	-
	R662636	Refuerzo base de cuerpo interior		1	1	-	-	1
	R682633	Refuerzo base de cuerpo interior		-	-	1	1	-
	R682663	Refuerzo vertical de cuerpo interior		-	-	2	2	-
	Q232040	Arandela plana A-6		8	8	21	21	8
	Q262040	Arandela muelle A-6		8	8	21	21	8
	Q162040	Tuerca exagonal M-6		8	8	21	21	8
45	Q222041	Remache exagonal M-4 inox.		24	28	28	28	24

Зип-бещепит

vs 71000

17(812)287-08-81

4

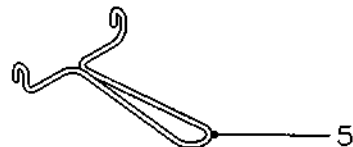

5

3

1

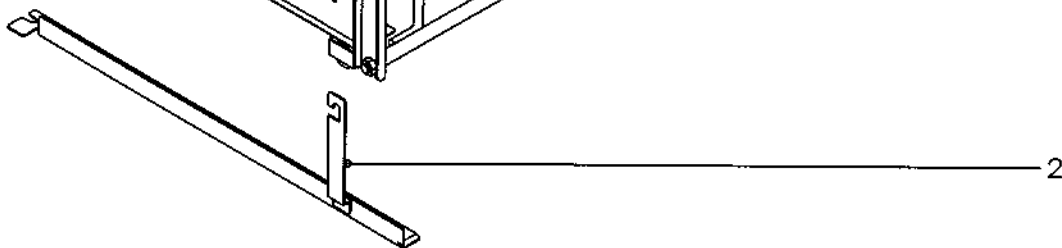

2

N plano C-1446	Firma 	Fecha 11-2003	Aparato EXTRACTURAS PORTABANDEJAS HORNOS MIX. ELECTROMECAICOS	Lamina 4	Fagor Industrial S.Coop. FAGOR Onate
-------------------	-----------	------------------	---	-------------	--

Зип Общепит

vsezip.ru

+7(812)987-08-81

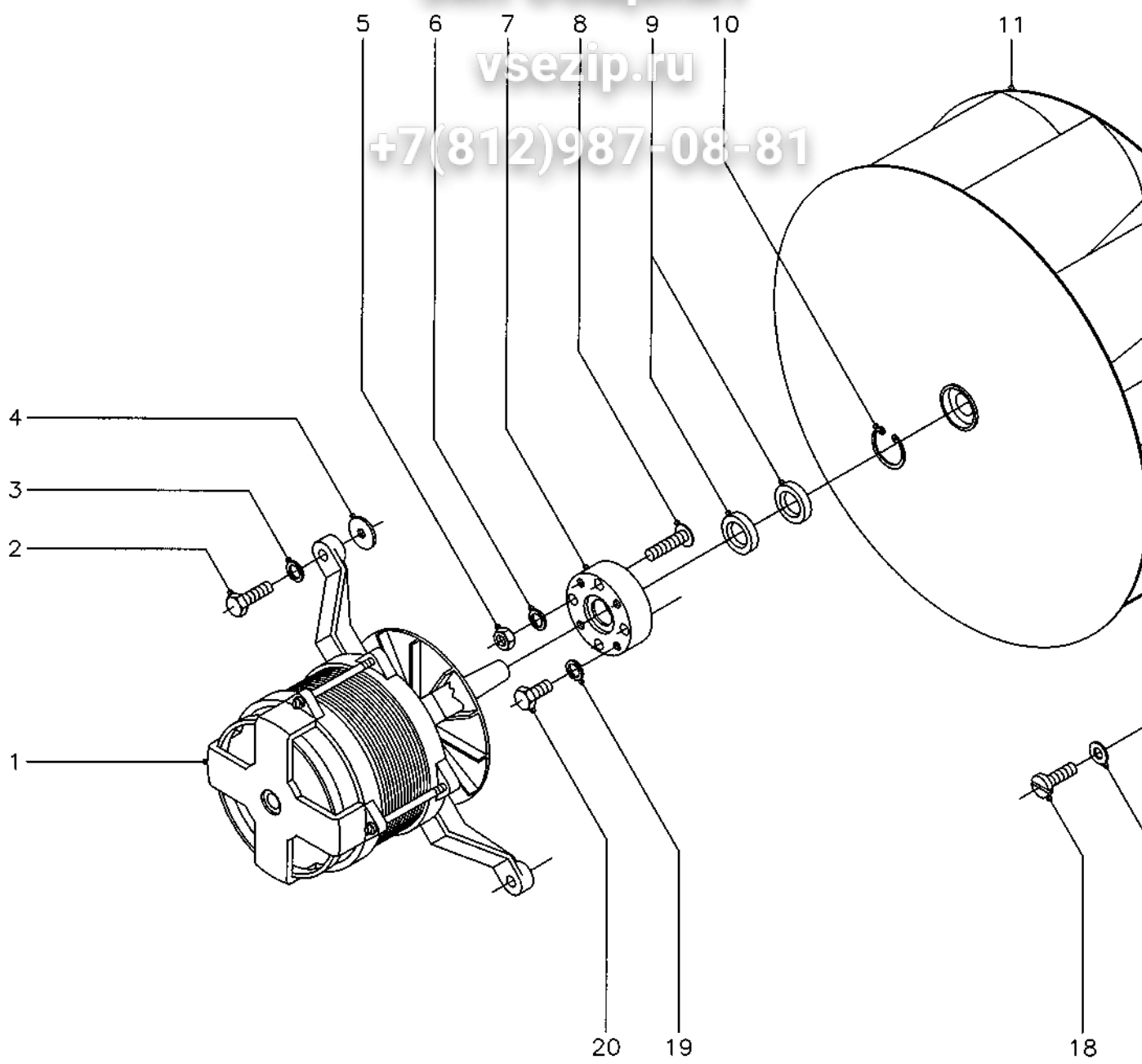

N plano
C-1447



Fecha
11-2003

Aparato
HORNOS MIX. ELECTROMECANICOS

Laminio
5

Fagor Industrial S. Coop. Oñate
FAGOR

TURBINA

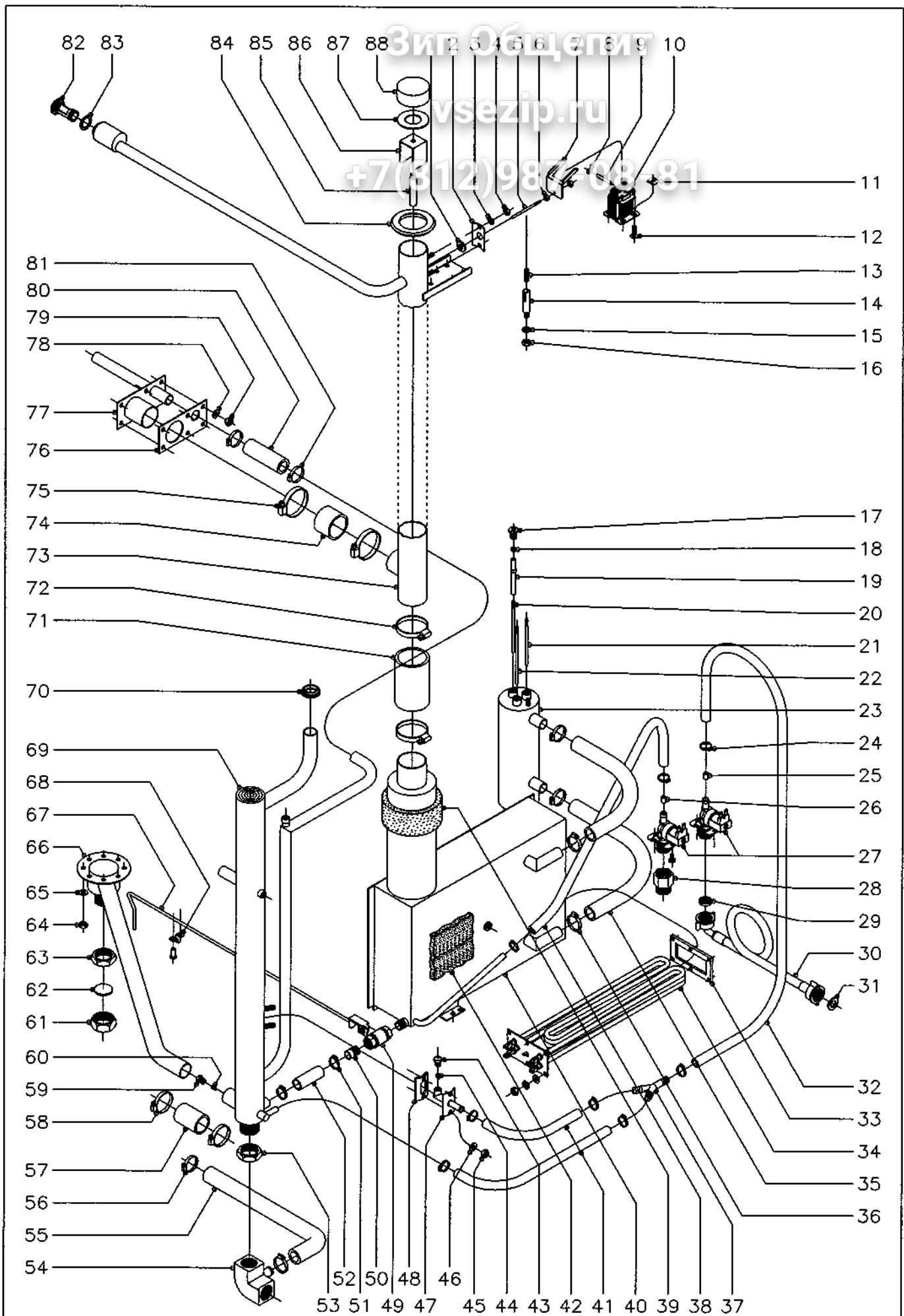

N plano C-1448	Firma <i>Duqueno</i>	Fecha 11-2003	Aparato HORNOS MIX. ELECTROMECHANICOS	CIRCUITO DE AGUA	Lamina 6	Fagor Industrial S.Coop. FAGOR Onate
-------------------	-------------------------	------------------	--	------------------	-------------	--

+7(812)987-08-81

MOD.	HORNOS MIXTOS ELECTROMECAÑICOS	ZONA	CIRCUITO DE AGUA					
ITEM	CODIGO	DENOMINACION	TEXTO	HMM-6/11	HMM-10/11	HMM-10/21	HMM-2-10/11	HMM-6/11 UL
1	R675033	Junta palanca accionamiento		1	1	1	1	1
2	T115105	Amarre junta a conduccion vahos		1	1	1	1	1
3	Q242030	Arandela abanico A-5		2	2	2	2	2
4	Q162030	Tuerca exagonal M-5		2	2	2	2	2
5	R675014	Palanca accionamiento		1	1	1	1	1
6	Q162020	Tuerca exagonal M-4		2	2	2	2	2
7	R672640	Escuadra accionamiento		1	1	1	1	1
8	Q301035	Sujecion rapida Ø4		2	2	2	2	2
9	R675016	Pasador electroiman		1	1	1	1	1
10	R663030	Electroiman		1	1	1	1	1
11	Q221012	Tuerca rapida M-5		2	2	2	2	2
12	Q152004	Tomillo aplastado M-5x13		2	2	2	2	2
13	Z883001	Resorte		1	1	1	1	1
14	R665027	Guia resorte		1	1	1	1	1
15	Q242040	Arandela abanico A-6		1	1	1	1	1
16	Q162040	Tuerca exagonal M-6		1	1	1	1	1
17	R345058	Racord amarre electrodos		3	3	3	3	3
18	Q163020	Tuerca exagonal M-4		6	6	6	6	6
19	R345059	Guia aislante de electrodos		3	3	3	3	3
20	R345063	Electrodo nivel bajo L=116		1	1	1	1	1
21	R345060	Electrodo nivel alto L=106		1	1	1	1	1
22	R345064	Electrodo de masa L=131		1	1	1	1	1
23	R665046	Cuerpo de niveles		1	-	-	-	1
23	R025011	Cuerpo de niveles		-	1	1	1	-
24	Q881302	Abrazadera 12 - 20		4	4	4	4	4
25	P443042	Regulador caudal (3 l./m.) negro		1	1	1	1	1
26	Z601156	Regulador caudal (8 l./m.) rojo		1	1	1	1	1
27	Z701135	Electrovalvula entrada agua		2	2	2	2	2
	Q032021	Tomillo alomado M-4x10		4	4	4	4	4

MOD.	HORNOS MIXTOS ELECTROMECANICOS	ZONA	CIRCUITO DE AGUA					
ITEM	CODIGO	DENOMINACION	TEXTO	HMM-6/11	HMM-10/11	HMM-10/21	HMM-2-10/11	HMM-6/11 UL
28	T125033	Adaptador a rosca UL		-	-	-	-	1
29	Z701132	Filtro-junta entrada de agua		1	1	1	1	1
30	Z601114	Manguera entrada de agua		2	2	2	2	-
31	Q307031	Arandela junta Ø24xØ14x3		2	2	2	2	2
32	3676900	Tubo de goma Ø17xØ10x900		1	1	1	1	1
33	R145012	Junta cierre resistencias		1	2	2	2	1
34	R143000	Resistencia (3000W.x3, 230 V.)		1	2	2	2	1
	Q232030	Arandela plana A-5		6	12	12	12	6
	Q242030	Arandela abanico A-5		6	12	12	12	6
	Q162030	Tuerca exagonal M-5		6	12	12	12	6
35	3715600	Tubo silicona forra. Ø26xØ18x400		2	2	2	2	2
36	Q881305	Abrazadera 25 - 40		4	4	4	4	4
37	Z201106	Racord en " Y "		1	1	1	1	1
38	3676900	Tubo de goma Ø17xØ10x500		1	1	1	1	1
39	R665052	Aislante salida generador		1	-	-	-	-
39	R345013	Aislante salida generador		-	1	1	1	-
39	R672630	Aislante salida generador		-	-	-	-	1/2.
40	R665042	Generador de vapor		1	-	-	-	1
40	R675024	Generador de vapor		-	1	1	1	-
41	3676900	Tubo de goma Ø17xØ10x400		2	2	2	2	2
42	R665051	Aislante cuerpo generador		1	-	-	-	-
42	R345011	Aislante cuerpo generador		-	1	1	1	-
42	R672630	Aislante cuerpo generador		-	-	-	-	1/2.
43	Z651931	Tobera		1	1	1	1	1
44	Z651932	Rodete		1	1	1	1	1
45	Q162030	Tuerca exagonal M-5		2	2	2	2	2
46	Q232030	Arandela plana A-5		2	2	2	2	2
47	R015007	Conduccion vahos		1	1	1	1	1

MOD.		HORNOS MIXTOS ELECTROMECANICOS		ZONA	CIRCUITO DE AGUA				
					+7(812)987-08-81				
ITEM	CODIGO	DENOMINACION	TEXTO	HMM-6/11	HMM-10/11	HMM-10/21	HMM-2-10/11	HMM-6/11 UL	
48	R345108	Junta conduccion vahos		1	1	1	1	1	
49	R015034	Cuerpo grifo vaciado		1	1	1	1	1	
50	R345014	Manguito grifo vaciado		1	1	1	1	1	
51	Q881304	Abrazadera 20 - 32		2	2	2	2	2	
52	3715600	Tubo silicona Ø26xØ18x120		1	1	1	1	1	
53	Q223014	Contratuerca 1"		1	1	1	1	1	
54	R665067	Codo desagüe		1	1	1	1	1	
55	3715600	Tubo silicona Ø26xØ18x1000		1	1	1	1	1	
56	Q881304	Abrazadera 20 - 32		2	2	2	2	2	
57	3714100	Tubo silicona Ø38xØ31x100		1	1	1	1	1	
58	Q881305	Abrazadera 25 - 40		2	2	2	2	2	
59	Z651931	Tobera		1	1	1	1	1	
60	Z651932	Rodete		1	1	1	1	1	
61	R665053	Tuerca tapon 1"		1	1	1	1	1	
62	R015011	Arandela junta tapon Ø34x3		1	1	1	1	1	
63	Q223014	Contratuerca 1"		1	1	1	1	1	
64	Q162040	Tuerca exagonal M-6		8	8	8	8	8	
65	Q232040	Arandela plana A-6		8	8	8	8	8	
66	R675022	Tubo de desagüe		1	1	-	-	1	
66	R685006	Tubo de desagüe		-	-	1	1	-	
67	R342803	Palanca de grifo de vaciado		1	1	-	-	1	
67	R032804	Palanca de grifo de vaciado		-	-	1	1	-	
68	Q901306	Grapa amarre palanca grifo		1	1	1	1	1	
	Q412002	Remache tubular Ø 4x7,5		2	2	2	2	2	
69	R665048	Tubo retorno y chimenea		1	-	-	-	1	
69	R675030	Tubo retorno y chimenea		-	1	-	-	-	
69	R685010	Tubo retorno y chimenea		-	-	1	1	-	
70	N503017	Soporte termostato		1	1	1	1	1	
71	R345020	Tubo empalme generador		1	1	1	1	1	

Зип Общепит

vsezip.ru

+7(812)987-08-81

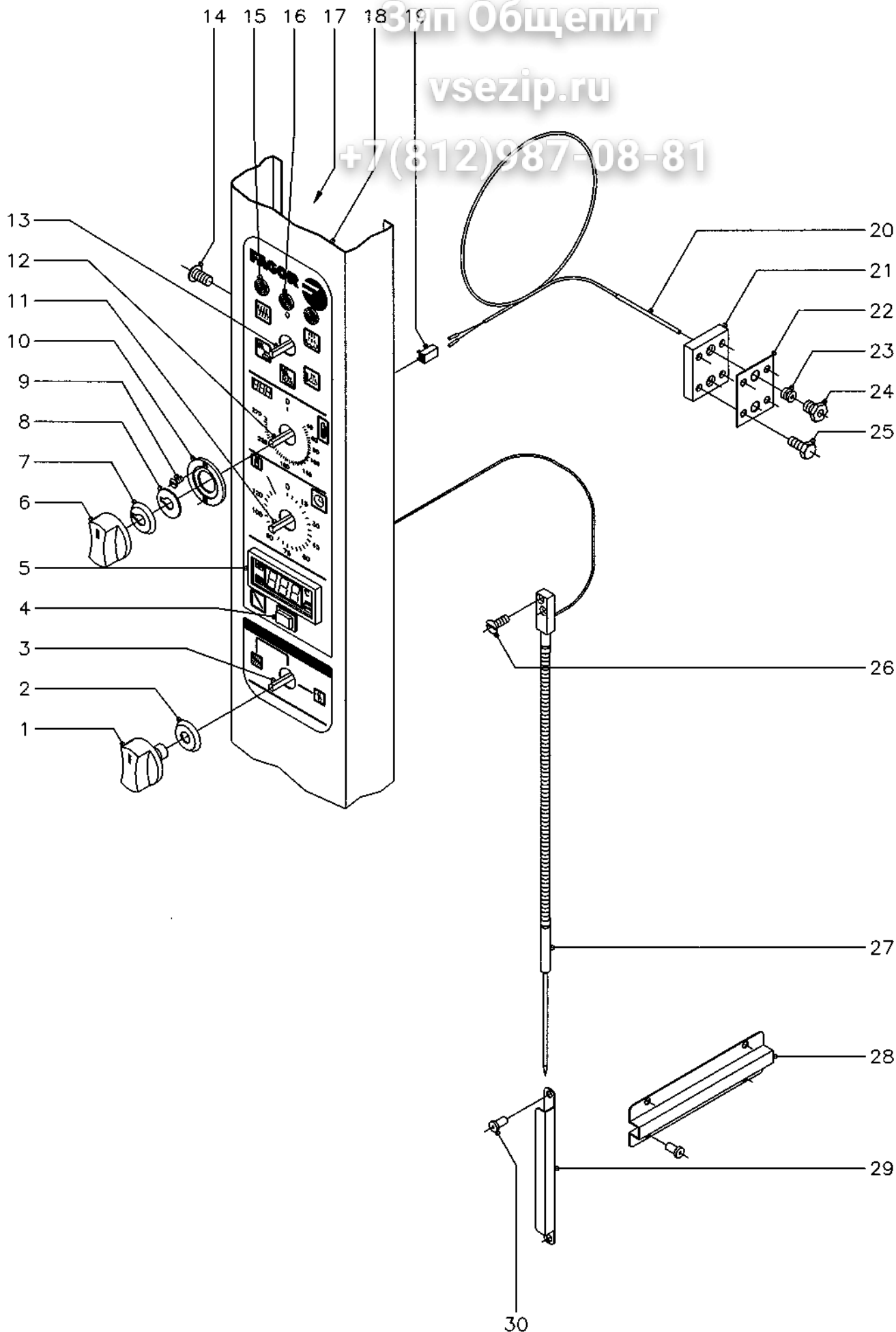

N plano C-1449	Firma 	Fecha 11-2003	Aparato SISTEMA ELECTRICO PORTAMANDOS HORNOS MIX. ELECTROMECHANICOS	Lamina 7	Fagor Industrial S.Coop. FAGOR
-------------------	-----------	------------------	---	-------------	---------------------------------------

MOD.		HORNOS MIXTOS ELECTROMECANICOS		ZONA	SISTEMA ELECTRICO PORTAMANDOS				
ITEM	CODIGO	DENOMINACION	TEXTO	HMM-6/11	HMM-10/11	HMM-10/21	HMM-2-10/11	HMM-6/11 UL	
1	R663062	Boton de mando (conmutadores)		2	3	3	3	2	
1	R663070	Boton de mando (conmutadores)		-	-	-	-	2	
2	R663046	Junta (conmutadores)		2	3	3	3	2	
3	R753000	Conmutador de potencia		-	1	1	1	-	
4	R743008	Interruptor regulacion sonda		1	1	1	1	1	
5	R743091	Termostato digital ° C.		1	1	1	1	-	
5	R743035	Termostato digital ° F.		-	-	-	-	1	
6	R663063	Boton de mando (circuito impreso)		1	1	1	1	1	
6	R663071	Boton de mando (circuito impreso)		-	-	-	-	1	
7	R663045	Junta (circuito impreso)		1	1	1	1	1	
8	R662810	Arandela guia		1	1	1	1	1	
9	Q151346	Tornillo avellanado M-3x5		2	2	2	2	2	
10	R662809	Guia boton de mando		1	1	1	1	1	
11	R723000	Temporizador manual		1	1	1	1	1	
12	R743013	Termostato electronico 270°C.		1	1	1	1	-	
12	R693058	Termostato electronico 500°F.		-	-	-	-	1	
13	R743002	Conmutador de funciones		1	1	1	1	1	
14	Q152004	Tornillo aplastado M-5x13		3	3	3	3	3	
15	R693056	Piloto ambar		2	2	2	2	2	
16	R693055	Piloto verde		1	1	1	1	1	
17	R742803	Soporte componentes		1	1	1	1	1	
18	R742807	Panel portamandos 6/11		1	-	-	-	1	
18	R752805	Panel portamandos 10/11 y 10/21		-	1	1	1	-	
19	R663092	Conector 2 vias		1	1	1	1	1	
20	R663090	Conjunto termopar L=1500		1	1	1	1	1	
21	R662659	Pasamuros doble para sonda		1	1	1	1	1	
22	R692811	Junta pasamuros doble		1	1	1	1	1	
23	R662652	Bicono cierre sonda		1	1	1	1	1	
24	R662629	Racord cierre sonda		1	1	1	1	1	

ЗипОбщепит

vsezip.ru

+7(812)987-08-81

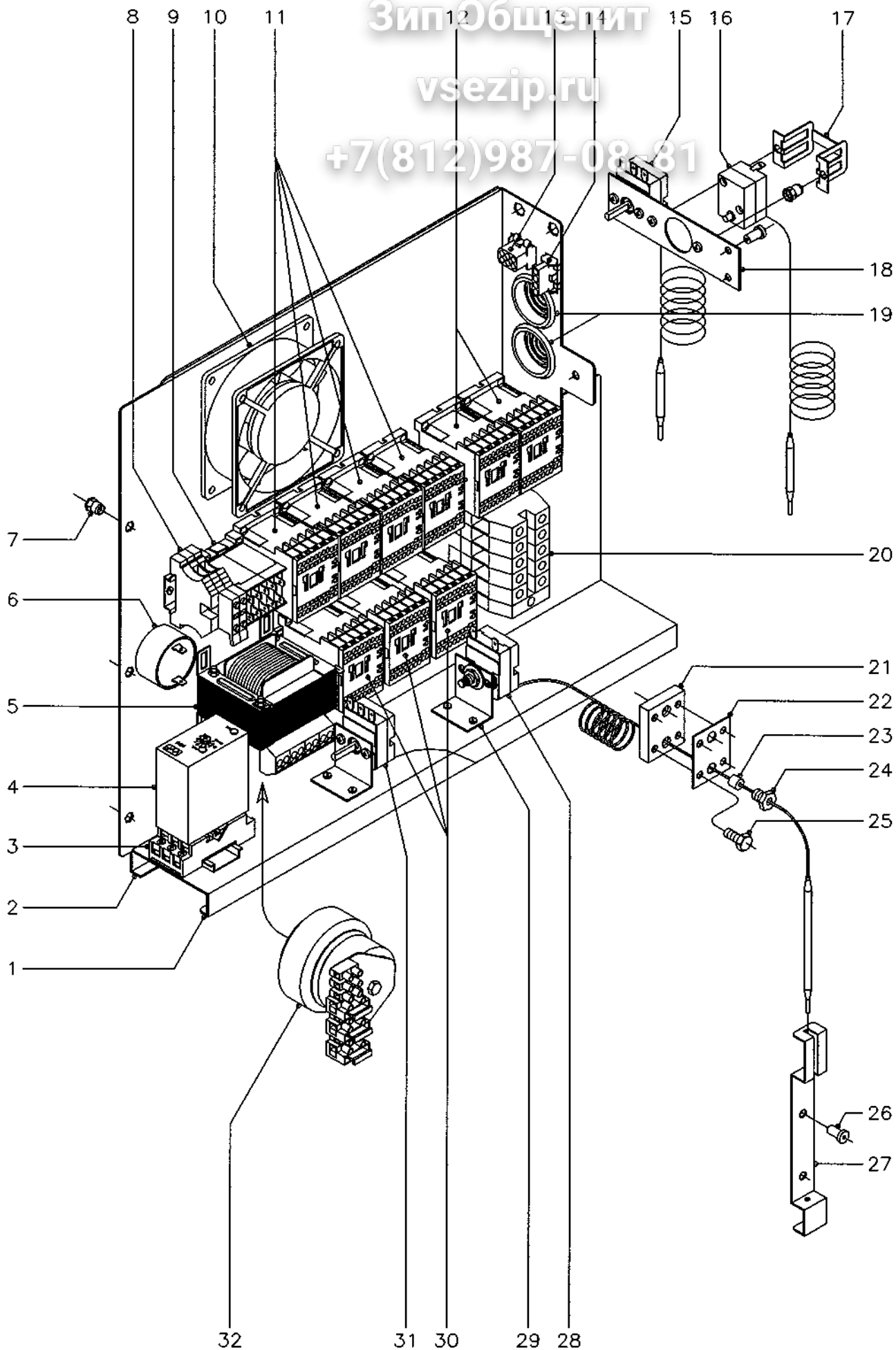

N plano
C-1450

Firma

Fecha
11-2003

Aparato
CUADRO ELECTRICO
HORNOS MIX. ELECTROMECHANICOS

Lamina
8

Fagor Industrial S.Coop. **FAGOR**
Onate

+7(812)987-08-81

MOD.	HORNOS MIXTOS ELECTROMECHANICOS	ZONA	CUADRO ELECTRICO					
ITEM	CODIGO	DENOMINACION	TEXTO	HMM-6/11	HMM-10/11	HMM-10/21	HMM-2-10/11	HMM-6/11 UL
1	R663081	Panel cuadro electrico		1	1	1	1	1
2	R663018	Contra guia panel cuadro		1	1	1	1	1
	Q412002	Remache tubular Ø4x7,5		7	7	7	7	7
3	R743009	Base enchufable		1	1	1	1	1
	Z123018	Guia contactor L=55		1	1	1	1	1
4	R343072	Detector de niveles		1	1	1	1	-
4	R743031	Detector de niveles		-	-	-	-	1
5	R503005	Transformador		1	1	1	1	-
6	R693067	Zumbador		1	1	1	1	1
7	Q221342	Remache exagonal M-5		3	3	3	3	3
8	R073005	Bornas portafusibles		2	2	2	2	2
	P184011	Cartucho fusible 4 A.		2	2	2	2	2
	Z263303	Tope final		1	1	1	1	1
9	Z683087	Contacto 3TF20 01 - 3AL2 (230 V.)		1	1	1	1	1
	Z263303	Tope final		1	1	1	1	1
10	Z103066	Ventilador		1	1	1	1	1
11	Z203050	Contacto sirius 3RT-1016-2AP01		2	4	4	4	2
	R693009	Guia contactor L=250		1	1	1	1	1
12	Z203050	Contacto sirius 3RT-1016-2AP01		2	2	2	2	2
	Z403016	Guia contactor L=100		1	1	1	1	1
13	-	Conector hembra 6 vias		1	1	1	1	1
14	-	Conector hembra 4 vias		1	1	1	1	1
15	R343100	Termostato de condensacion		1	1	1	1	1
	Q153111	Tornillo alomado M-4x8		2	2	2	2	2
16	Z213014	Termostato Tecasa de seguridad		1	1	1	1	1
17	Z203060	Amarre limitador Tecasa		1	1	1	1	1
	Q221341	Remache exagonal M-4		2	2	2	2	2
	Q153111	Tornillo alomado M-4x8		2	2	2	2	2
18	R673061	Soporte amarre termostatos		1	1	1	1	1

MOD.		HORNOS MIXTOS ELECTROMECANICOS		ZONA	CUADRO ELECTRICO				
ITEM	CODIGO	DENOMINACION	TEXTO	HMM-6/11	HMM-10/11	HMM-10/21	HMM-2-10/11	HMM-6/11 UL	
	Q412002	Remache tubular Ø4x7,5		2	2	2	2	2	
19	N103013	Pasacables		2	2	2	2	2	
20	P453025	Borne gris fases 10		3	-	-	-	3	
	R263003	Borne gris fases 35		-	3	3	3	-	
	Z263302	Borne azul neutro 10		1	-	-	-	1	
	R673010	Borne azul neutro 35		-	1	1	1	-	
	P453026	Borne verde-amarillo tierra 10		1	-	-	-	1	
	Z103035	Borne verde-amarillo tierra 35		-	1	1	1	-	
	Z263303	Tope final		1	-	-	-	1	
	Z683096	Tope final 35		-	1	1	1	-	
	Z683068	Señalización bornes		1	1	1	1	1	
	R663055	Guía contactor 120		1	1	1	1	1	
21	R662659	Pasamuros doble para sonda		1	1	1	1	1	
22	R692811	Junta pasamuros doble		1	1	1	1	1	
23	R662662	Junta cierre bulbo limitador		1	1	1	1	1	
24	R662629	Racord cierre sonda		1	1	1	1	1	
25	Q012021	Tornillo exagonal M-4x10		4	4	4	4	4	
26	Q412002	Remache tubular Ø4x7,5		2	2	2	2	2	
27	R662630	Soporte de bulbo		1	1	1	1	1	
28	R243016	Termostato limitador temperatura		1	1	1	1	1	
29	R343039	Soporte de termostatos		2	2	2	2	2	
30	Z203050	Contactador sirius 3RT-1016-2AP01		1	3	3	3	1	
	Z103084	Guía contactor 138		1	1	1	1	1	
31	R343018	Termostato a tubo retorno vapor		1	1	1	1	1	
32	R723063	Transformador UL		-	-	-	-	1	

MOD.		HORNOS MIXTOS ELECTROMECHANICOS		ZONA	VARIOS				
ITEM	CODIGO	DENOMINACION	TEXTO	HMM-6/11	HMM-10/11	HMM-10/21	HMM-2-10/11	HMM-6/11 UL	
	R746501	Folleto de instrucciones (FAGOR)		1	1	1	1	-	
	R696516	Folleto de instruccio. (FAGOR UL)		-	-	-	-	1	
	R746503	Folleto de instrucciones (M F)		-	-	-	-	1	
	R743039	Esquema electrico adhesivo		1	-	-	-	-	
	R743040	Esquema electrico adhesivo (MF)		-	-	-	-	1	
	R743041	Esquema electrico adhesivo (UL)		-	-	-	-	1	
	R753013	Esquema electrico adhesivo		-	1	1	1	-	
	R753022	Esquema electrico adhesivo (MF)		-	-	-	-	-	
	R753024	Esquema electrico adhesivo (UL)		-	-	-	-	-	
	R703040	Esquema electrico de montaje		1	-	-	-	1	
	R503004	Esquema electrico de montaje		-	1	1	1	-	
	R503009	Instalacion electrica HMM		1	1	1	1	-	
	R503008	Instalacion electrica HMM (UL)		-	-	-	-	1	
	R693066	Cableado fuerza conveccion		1	-	-	-	-	
	R743062	Cableado fuerza conveccion (UL)		-	-	-	-	1	
	R143005	Cableado fuerza conveccion		-	1	1	1	-	
	R143015	Cableado fuerza conveccion (UL)		-	-	-	-	-	
	R663074	Instalacion fuerza cuadro electrico		1	-	-	-	-	
	R743060	Instalacion fuerza cuadro elec. (UL)		-	-	-	-	1	
	R673013	Instalacion fuerza cuadro electrico		-	1	1	1	-	
	R753020	Instalacion fuerza cuadro elec. (UL)		-	-	-	-	-	
	R663095	Cableado luz interior		1	1	1	1	1	
	R663094	Cableado luz puerta		1	1	1	1	-	
	R693053	Cableado luz puerta (UL)		-	-	-	-	1	
	3713900	Funda roja-negra Ø6,4x500		1	1	1	1	1	
	R663075	Cableado fuerza vapor		1	-	-	-	-	

Зип Общепит

vsezip.ru

+7(812)987-08-81

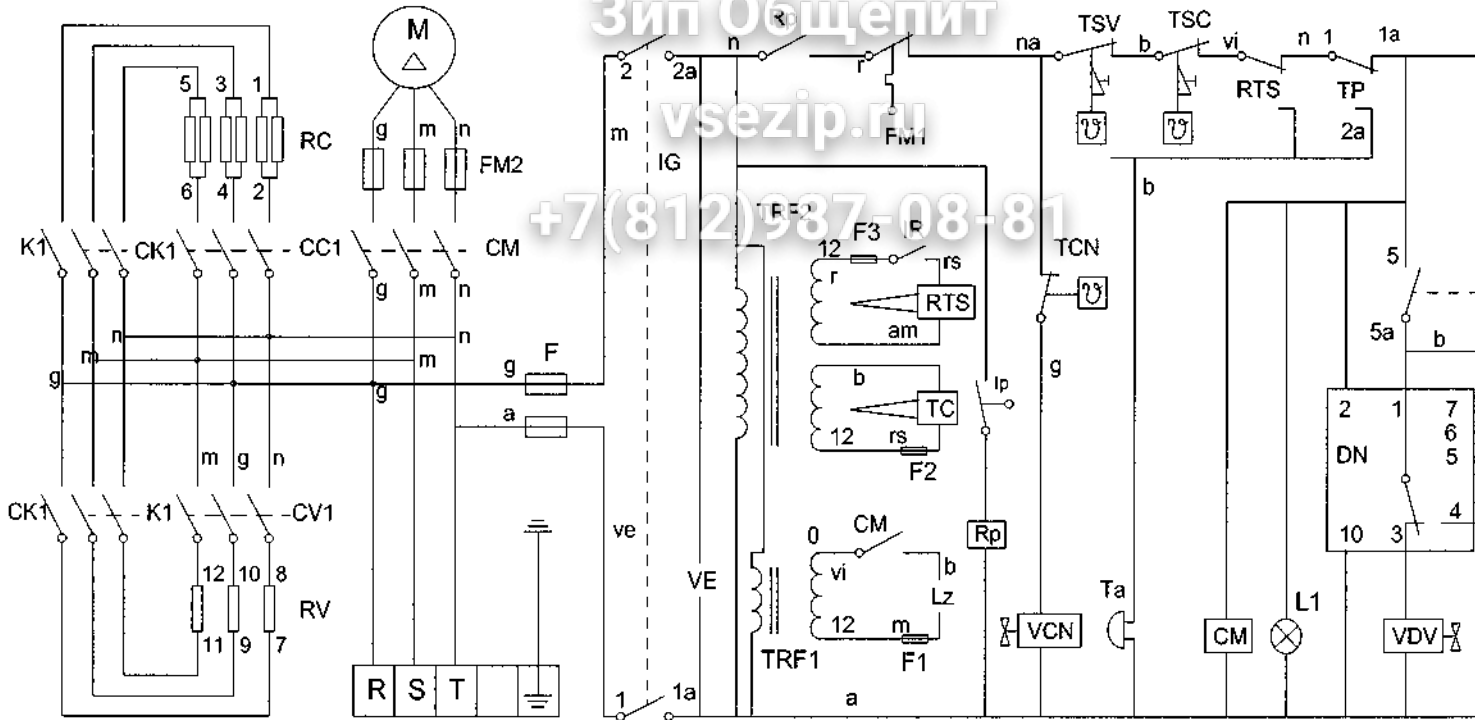

FM2 = Motor fuse

IP = Door's switch

IG = General switch

F = Fuse

CM = Motor's relay

VDV = Steamer's solenoid

DN = Water level control

FM1 = Motor's thermal protection

TSV = Steamer's security thermostat

TSC = Convection's security thermostat

LZ = Indoor light

IR = Probe selector

RTS = Probe controller

RV = Steamer elements

ET = Chimney solenoid

VCN = Steamer condenser solenoid

TC = Convection thermostat

T100 = 100 °C thermostat

TV = Steamer's thermostat

M = Motor

CC1 = Heating air relays

CV1 = Heating water relays

CK1, K1 = Elements relays

TCN = Steam condenser thermostat

RC = Heating element

TRF2 = Transformer (Electronic thermostat)

VE = Control panel's fan

Ta = Alarm

Tp = Manual Timer

F1, F2, F3 = Transformer fuse

TRF1 = Transformer (Indoor light)

L1 = Pilot lamp (on/off)

L2 = Pilot lamp (Heating water)

L3 = Pilot lamp (Heating air)

Rp = Door's Relay

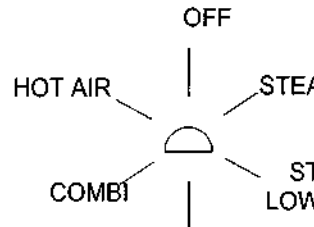

REGENERATION

am/ve = amarillo/verde-yellow

am = amarillo-yellow-jaune

a = azul-blue-bleu

b = blanco-white-blanc

g = gris-grey -gris

ve = verde-green-vert

3N 60Hz 208/220/240V

Зип Общежит

vsezip.ru

+7(812)987-08-81

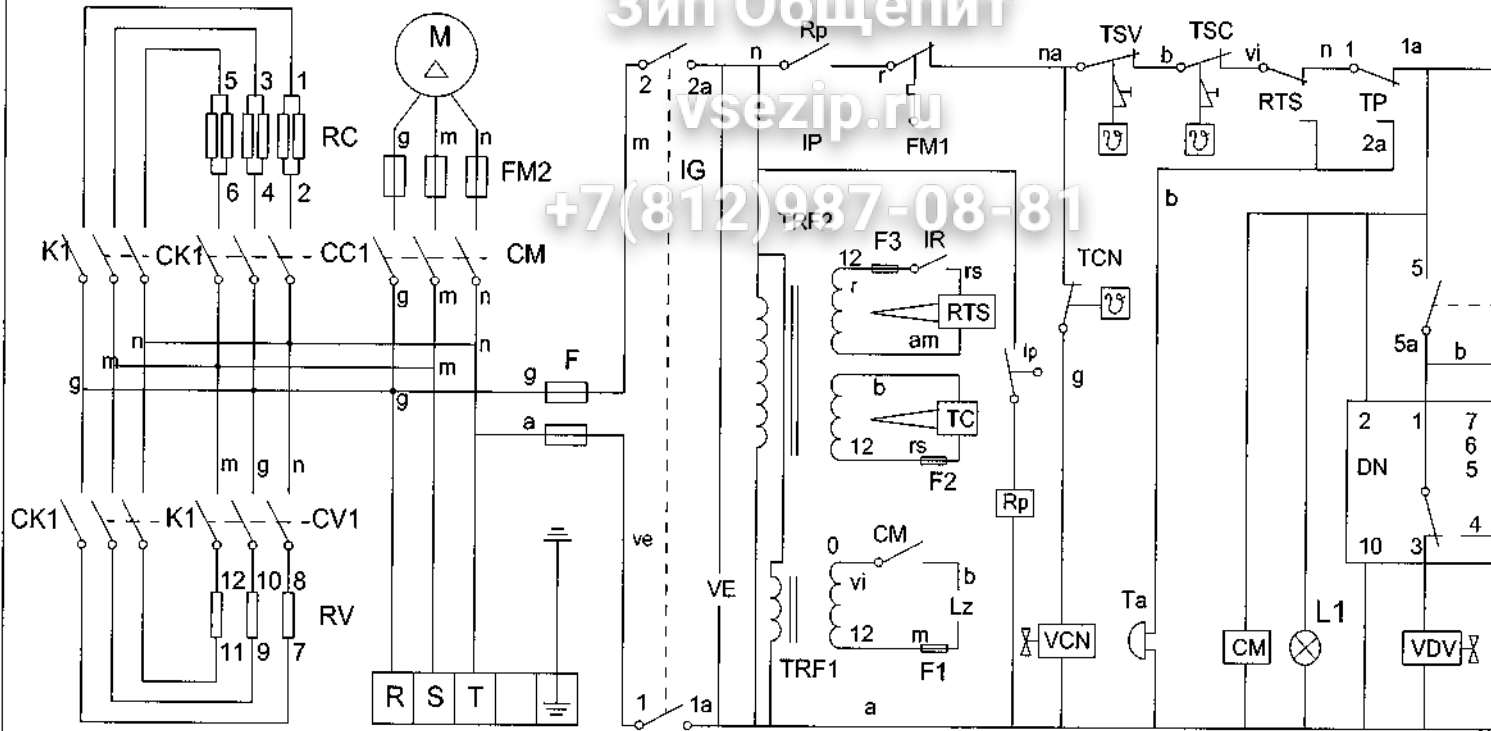

- FM2 = Motor fuse
- IP = Door's switch
- IG = General switch
- F = Fuse
- CM = Motor's relay
- VDV = Steamer's solenoid
- DN = Water level control
- FM1 = Motor's thermal protection
- TSV = Steamer's security thermostat
- TSC = Convection's security thermostat
- LZ = Indoor light
- IR = Probe selector
- RTS = Probe controller

- RV = Steamer elements
- ET = Chimney solenoid
- VCN = Steamer condenser solenoid
- TC = Convection thermostat
- T100 = 100 °C thermostat
- TV = Steamer's thermostat
- M = Motor
- CC1 = Heating air relays
- CV1 = Heating water relays
- CK1, K1 = Elements relays
- TCN = Steam condenser thermostat
- RC = Heating element
- TRF2 = Transformer (Electronic thermostat)

- VE = Control panel's fan
- Ta = Alarm
- Tp = Manual Timer
- F1, F2, F3 = Transformer fuse
- TRF1 = Transformer (Indoor light)
- L1 = Pilot lamp (on/off)
- L2 = Pilot lamp (Heating water)
- L3 = Pilot lamp (Heating air)
- Rp = Door's Relay

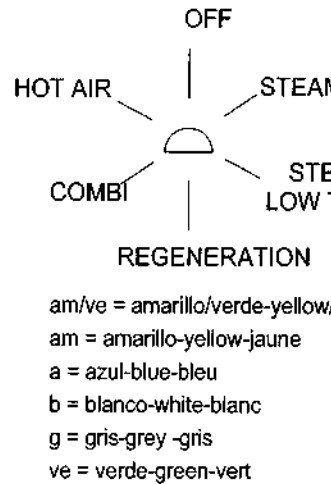

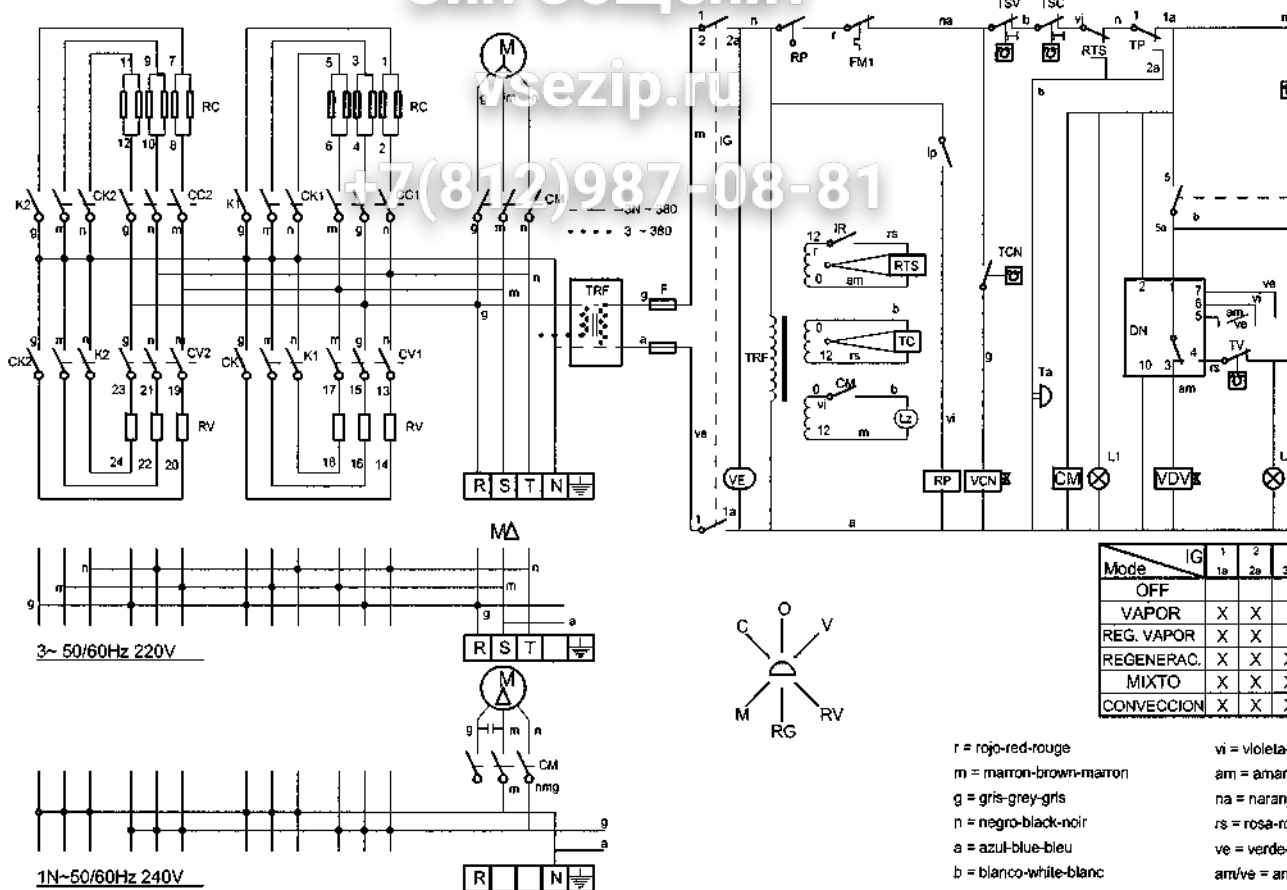

- IP = Interruptor puerta
- IG = Interruptor general
- F = Fusible
- CM = Contactor motor
- VDV = Electroválvula calderín
- DN = Detector de nivel
- FM1 = Térmico motor
- Tsv = Termostato seguridad vapor
- Tsc = Termostato seguridad cámara
- Lz = Luz interior
- IR = Selector regulador sonda nucleo
- RTS = Regulador temperatura sonda nucleo
- RV = Resistencias vapor
- VE = Ventilador cuadro eléctrico
- Ta = Timbre avisador
- Tp = Temporizador
- Rp: Relé puerta

- ET = Electroimán de apertura de tiro
- lc = Selector de potencia
- VCN = Electroválvula de condensación de vapor
- TC = Termostato cámara
- T100 = Termostato fijo 100°C
- TV = Termostato vapor
- M1 = Motor
- CC1 CC2 = Contactor resistencia cámara
- CV1 CV2 = Contactor resistencia vapor
- CK1, CK2, K1, K2 = Relé resistencias
- TCN = Termostato de condensacion de vapor
- RC = Resistencias cámara
- TRF = Transformador
- L1 = Lámpara de funcionamiento
- L2 = Lámpara de calentamiento vapor
- L3 = Lámpara de calentamiento cámara

MEDIDAS 225X127

Mode	IG		
	1a	2a	3a
OFF			
VAPOR	X	X	
REG. VAPOR	X	X	
REGENERAC.	X	X	X
MIXTO	X	X	X
CONVECCION	X	X	X

- r = rojo-red-rouge
- m = marron-brown-marron
- g = gris-grey-gris
- n = negro-black-noir
- a = azul-blue-bleu
- b = blanco-white-blanc
- vi = violeta
- am = amarillo
- na = naranja
- rs = rosa-ros
- ve = verde
- am/ve = amarillo/verde

Esquema teórico adhesivo		
Nº	Pieza	
Nº	Modificación	
1	Introducir RP	
Firma		Fecha
Dibujado KONTXI		11/9/98
Proyectado		
Comprobado		
Escala		
		HC
Plano hau ez dabilte erabili ez benidatu g		

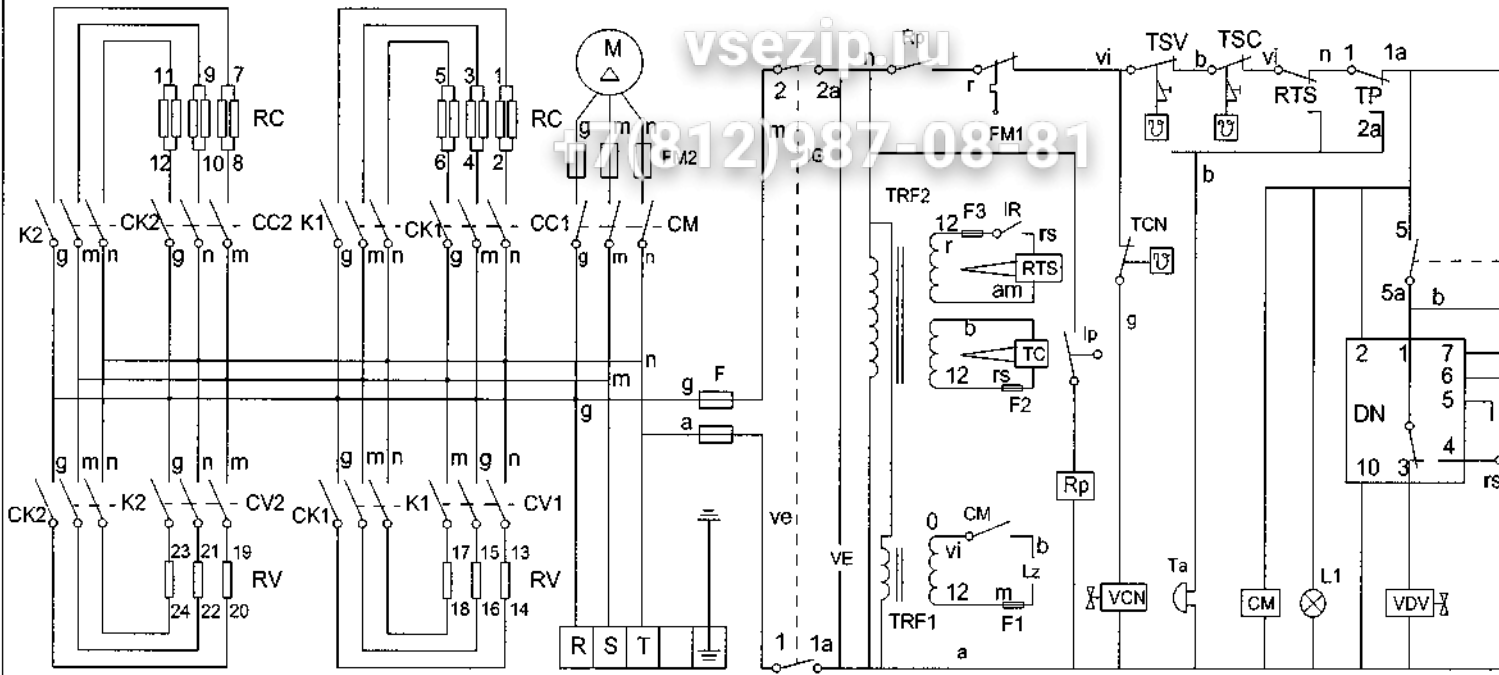

- FM2 = Motor fuse
- IP = Door's switch
- IG = General switch
- F = Fuse
- CM = Motor's relay
- VDV = Steamer's solenoid
- DN = Water level control
- FM1 = Motor's thermal protection
- TSV = Steamer's security thermostat
- TSC = Convection's security thermostat
- LZ = Indoor light
- IR = Probe selector
- RTS = Probe controller
- RV = Steamer elements

- ET = Chimney solenoid
- Ic = Power reduction switch
- VCN = Steamer condenser solenoid
- TC = Convection thermostat
- T100 = 100 °C thermostat
- TV = Steamer's thermostat
- M = Motor
- CC1, CC2 = Heating air relays
- CV1, CV2 = Heating water relays
- CK1, CK2, K1, K2 = Elements relays
- TCN = Steam condenser thermostat
- RC = Heating element
- TRF2 = Transformer (Electronic thermostat)

- VE = Control panel's fan
- Ta = Alarm
- Tp = Manual Timer
- F1, F2, F3 = Transformer fuse
- TRF1 = Transformer (Indoor light)
- L1 = Pilot lamp (on/off)
- L2 = Pilot lamp (Heating water)
- L3 = Pilot lamp (Heating air)
- Rp = Door's Relay

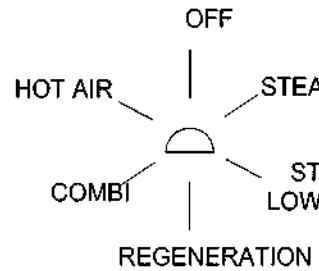

- am/ve = amarillo/verde-yellow-green
- am = amarillo-yellow-jaune
- a = azul-blue-bleu
- b = blanco-white-blanc
- g = gris-grey-gris
- ve = verde-green-vert

vsezip.ru

(812)987-0831

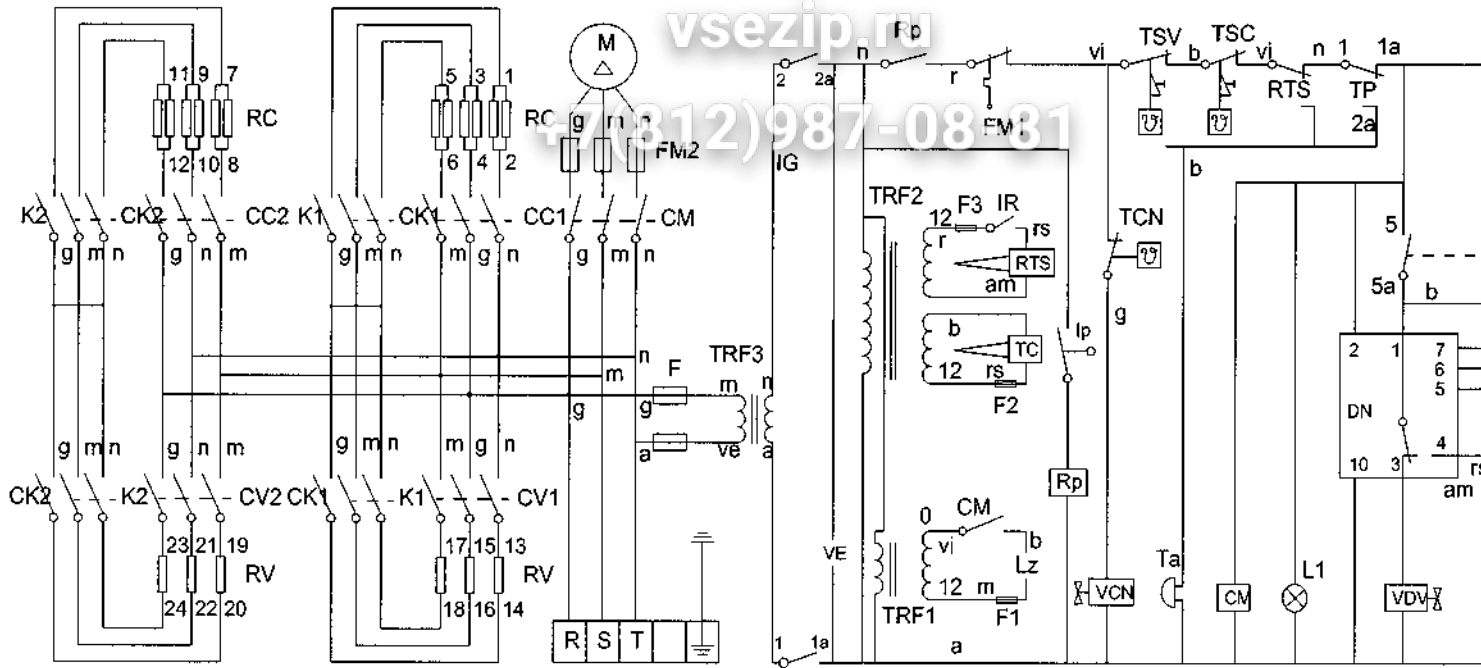

- FM2 = Motor fuse
- IP = Door's switch
- IG = General switch
- F = Fuse
- CM = Motor's relay
- VDV = Steamer's solenoid
- DN = Water level control
- FM1 = Motor's thermal protection
- TSV = Steamer's security thermostat
- TSC = Convection's security thermostat
- LZ = Indoor light
- IR = Probe selector
- RTS = Probe controller
- RV = Steamer elements

- ET = Chimney solenoid
- Ic = Power reduction switch
- VCN = Steamer condenser solenoid
- TC = Convection thermostat
- T100 = 100 °C thermostat
- TV = Steamer's thermostat
- M = Motor
- CC1, CC2 = Heating air relays
- CV1, CV2 = Heating water relays
- CK1, CK2, K1, K2 = Elements relays
- TCN = Steam condenser thermostat
- RC = Heating element
- TRF2= Transformer (Electronic thermostat)

- VE = Control panel's fan
- Ta = Alarm
- Tp = Manual Timer
- F1, F2, F3 = Transformer fuse
- TRF1 = Transformer (Indoor light)
- L1 = Pilot lamp (on/off)
- L2 = Pilot lamp (Heating water)
- L3 = Pilot lamp (Heating air)
- TRF3 = Transformer
- Rp = Door's Relay

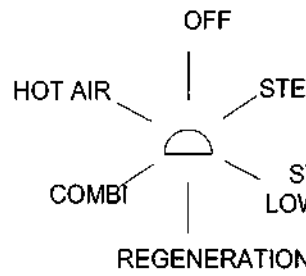

- am/ve = amarillo/verde-yellow/green
- am = amarillo-yellow-jaune
- a = azul-blue-bleu
- b = blanco-white-blanc
- g = gris-grey -gris
- ve = verde-green-vert



Зип Общепит
ysezip.ru
+7(812)987-08-81

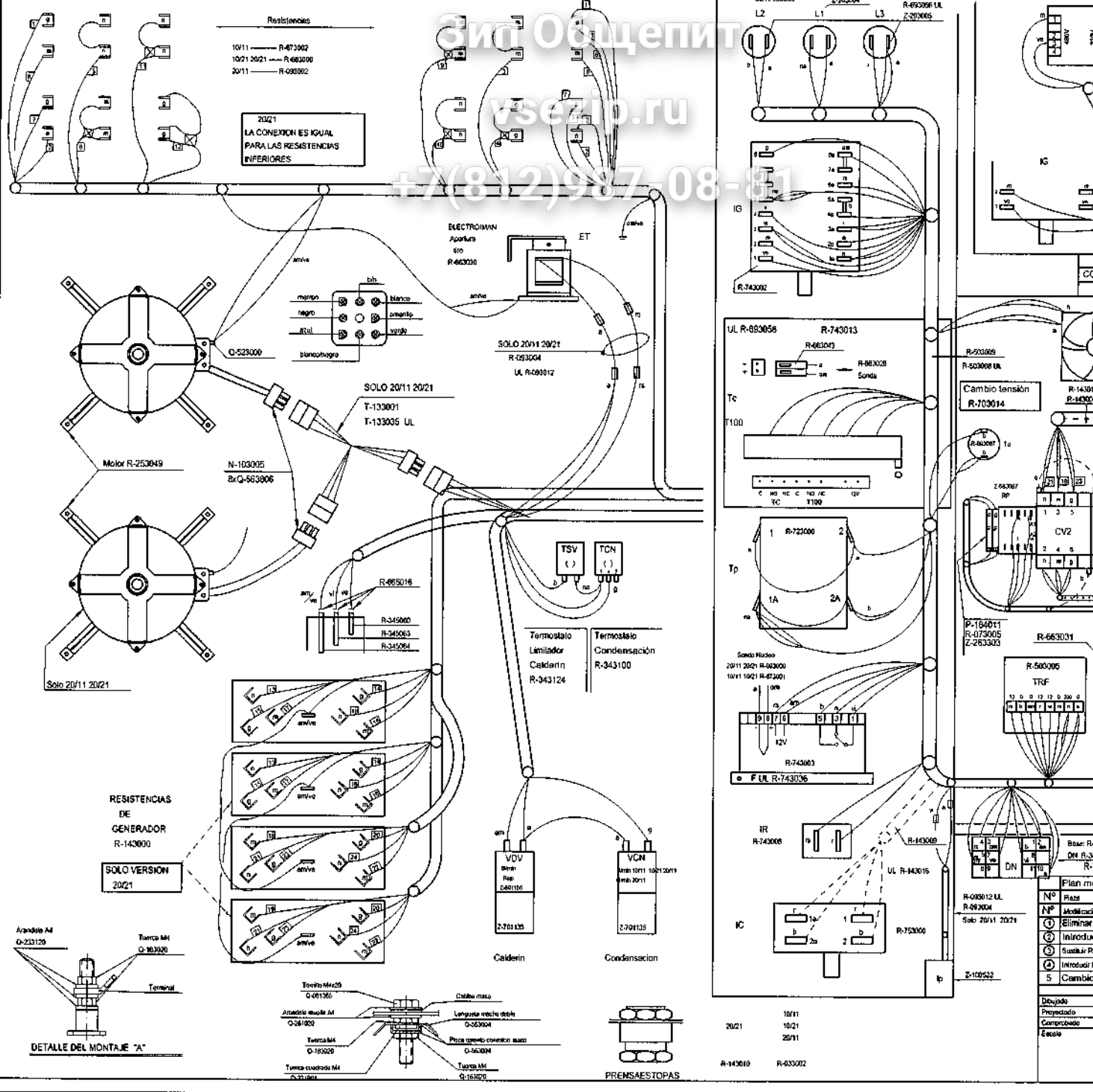

Base: R-7	Plan mo
DN R-34	R-7
Plan mo	Plan mo
Placa	Placa
Modificación	Modificación
Eliminar R-	Eliminar R-
Introducir R-	Introducir R-
Introducir R-	Introducir R-
Cambiar	Cambiar
Dibujado	Dibujado
Preparado	Preparado
Comprobado	Comprobado
Ensayo	Ensayo

R-09012 UL	10/11
R-043004	10/21
Solo 20/11 20/21	20/11
R-143010	R-033002