

Зип Общепит

DESPIECE TECNICO

vsezip.ru

+7(812)987-08-81

Lavavajillas
Lavevaisselle
Dishwasher
Geschirrspüler
Lavastoviglie

Modelos:

FI-72
FI-72 AR
FI-72W

Junio 2007 June



Fagor Industrial

Зип Общепит

vsezip.ru

878129870881

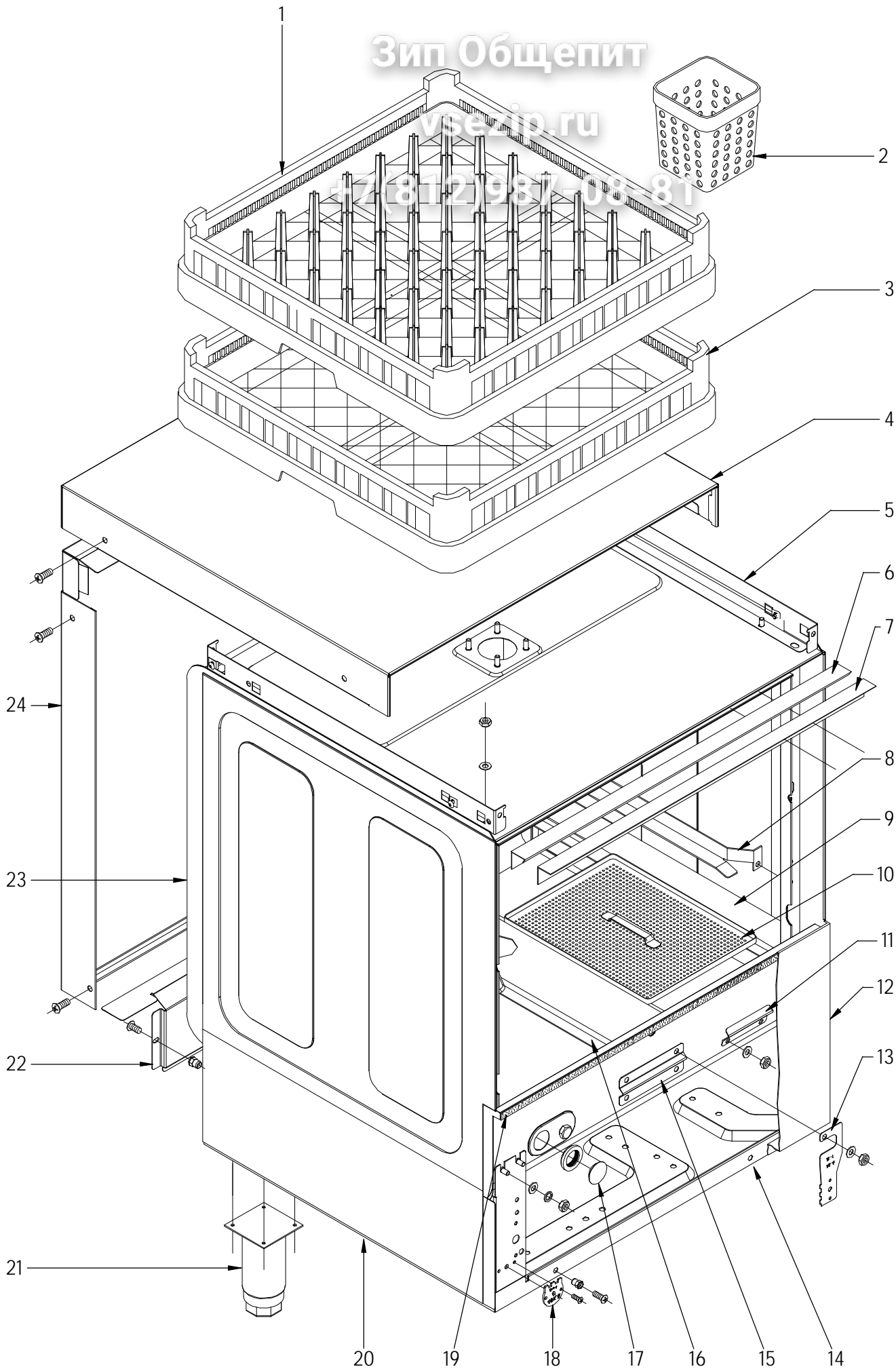

N plano	Firma	Fecha	Aparato	MUEBLE	Lamina	Fagor Industrial S.Coop. FAGOR
C-1857	<i>[Signature]</i>	2007-06	LAVAVAVAJILLAS FI-72		1	Oñate

Зип Общепит

MOD.	LAVAVAJILLAS DE APERTURA FRONTAL	ZONA	MUEBLE
-------------	---	-------------	---------------

ITEM	CODIGO	DENOMINACION	TEXTO	FI-72	FI-72 A.R	FI-72 W	
1	Z655302000	CESTILLO PLATOS CP-16-18		1	1	1	
	Z209121000	TOPE 50x50x80		2	2	2	
2	Z655314000	CESTILLO CUBIERTOS		4	4		
3	Z655301000	CESTILLO BASE CT-10		1	1	1	
S/Nº	Z685302000	CESTILLO BANDEJAS CB-7		1	1	1	
	Z685303000	REFUERZO CESTILLO BANDEJAS		1	1	1	
4	Z202906000	TAPA T-CO.		1	1	1	
	Q221342000	REMACHE EXAGONAL M5		2	2	2	
	Q152004000	TORNIL, APLASTADO M5x13 A304		2	2	2	
	Q152004000	TORNIL, APLASTADO M5x13 A304		4	4	4	
	Q221012000	TUERCA RAPIDA M,5		6	6	6	
	3713500000	PERFIL CUBREARISTAS PLASTICO		1	1	1	
5	Z200329000	ESCUADRA AMARRE TAPA AF		2	2	2	
	Q162040000	TUERCA EXAGONAL M6		4	4	4	
	Q232040000	ARANDELA A6		4	4	4	
	Q012073000	TORNILLO EXAGONAL M12X20		2	2	2	
	Q306024000	JUNTA18X12.5X1.5		2	2	2	
	Q162070000	TUERCA EXAGONAL M12		2	2	2	
6	Z200315000	PERFIL CAJA		1	1	1	
7	Z200309000	ESCUADRA SUJECCION PERFIL		1	1	1	
8	Z200305000	GUIA CESTILLO DERECHO		1	1	1	
	Q162040000	TUERCA EXAGONAL M6		2	2	2	
	Q232040000	ARANDELA A6		2	2	2	
S/Nº	Z200306000	GUIA CESTILLO IZQUIERDO		1	1	1	
	Q162040000	TUERCA EXAGONAL M6		2	2	2	
	Q232040000	ARANDELA A6		2	2	2	
9	Z210805000	SOPORTE DERECHO BANDEJAS		1	1	1	
	Q162040000	TUERCA EXAGONAL M6		2	2	2	
	Q232040000	ARANDELA A6		2	2	2	

Зип Общепит

MOD.		LAVAVAJILLAS DE APERTURA FRONTAL		ZONA	MUEBLE		
ITEM	CODIGO	DENOMINACION	TEXTO	FI-72	FI-72 A.R	FI-72 W	
S/Nº	Z210806000	SOPORTE IZDQUIERD. BANDEJAS		1	1	1	
	Q162040000	TUERCA EXAGONAL M6		2	2	2	
	Q232040000	ARANDELA A6		2	2	2	
10	Z210801000	BANDEJA COMPLETA		4	4	4	
11	Z431701000	CHAPA TERMOMETRO W		-	-	1	
	Q012073000	TORNILLO EXAGONAL M12X20		-	-	2	
	Q162070000	TUERCA EXAGONAL M12		-	-	2	
	Q306024000	JUNTA 18x12,5x1,5		-	-	2	
12	Z268313000	PANEL FRONTAL SIN PUERTA		1	1	1	
	Q152004000	TORNIL, APLASTADO M5x13 A304		2	2	2	
13	Z208435000	SOPORTE W TERMOST. TANQUE		-	-	1	
	Q162040000	TUERCA EXAGONAL M6		-	-	4	
	Q232040000	ARANDELA A6		-	-	4	
	Q262040000	ARANDELA GROW. A6 A.304		-	-	4	
14	Z260101000	ARMAZON COMPLETO FI-72		1	1	1	
15	Z748008000	SOPORTE BULBO TERMOSTATO		-	-	1	
	Q162040000	TUERCA EXAGONAL M6		-	-	2	
	Q232040000	ARANDELA A6		-	-	2	
	Q262040000	ARANDELA GROW. A6 A.304		-	-	2	
16	Z210804000	SOPORTE CENTRAL BANDEJAS		1	1	1	
17	P443060000	TAPON		-	-	1	
	N503017000	SOPORTE TERMOSTATO 1001713		-	-	1	
18	Z718446000	CHAPA W 85°C		-	-	1	
19	Z200313000	PERFIL GOMA ESPONJOSA		1	1	1	
20	Z262903000	PANEL LATERAL IZQUIERDO		1	1	1	
	Q152004000	TORNIL, APLASTADO M5x13 A304		2	2	2	
S/Nº	Z262902000	PANEL LATERAL DERECHO		1	1	1	
	Q152004000	TORNIL, APLASTADO M5x13 A304		2	2	2	
21	X260151000	PATA REGULABLE		4	4	4	
	Q411304000	REMACHE AVIBULB Ø4,8		12	12	12	

Зип Общепит

MOD.	LAVAVAJILLAS DE APERTURA FRONTAL	ZONA	MUEBLE
-------------	---	-------------	---------------

ITEM	CODIGO	DENOMINACION	TEXTO	FI-72	FI-72 A.R	FI-72 W	
22	Z262905000	PANEL POSTERIOR INFERIOR		1	1	1	
	Q152004000	TORNIL, APLASTADO M5x13 A304		2	2	2	
23	Z260325000	CAJA SOLDADA		1	1	1	
	Q162040000	TUERCA EXAGONAL M6		8	8	8	
	Q302022000	ARANDELA 16X6X1.2 A.304		8	8	8	
	Q262040000	ARANDELA GROW. A6 A.304		8	8	8	
	Q152018000	PERNO M6x10		—	—	4	
24	Z262904000	PANEL POSTERIOR FI-72		1	1	1	
	Q152004000	TORNIL, APLASTADO M5x13 A304		4	4	4	

Зип Общепит

vsezip.ru

+7(812)987-08-81

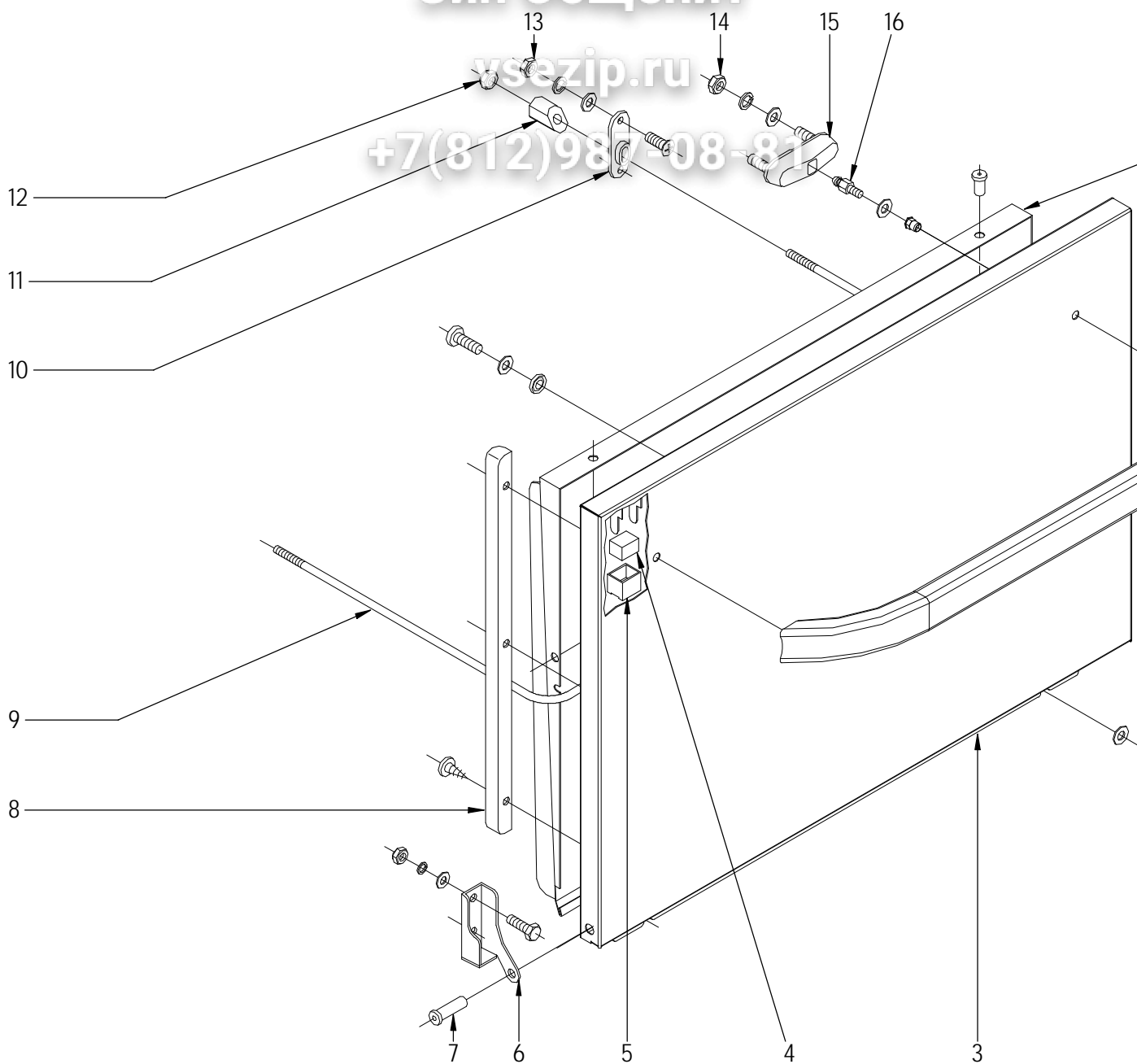

Número
C-1858

Firma
[Signature]

Fecha
2007-06

Aparato

PUERTA
LAVAVAJILLAS FI-72

Lamina
2

Fagor Industrial S. Coop.
Orfite



Зип Общепит

MOD.		LAVAVAJILLAS DE APERTURA FRONTAL		ZONA	PUERTA		
ITEM	CODIGO	DENOMINACION	TEXTO	FI-72	FI-72 A.R	FI-72 W	
1	Z260533000	CONTRAPUERTA SOLDADA		1	1	1	
	Q412000000	REMACHE TUBULAR 4 x 8		4	4	4	
	Q232030000	ARANDELA A5		2	2	2	
	Q162030000	TUERCA EXAGONAL M5		2	2	2	
	Q262030000	ARANDELA GROW. A5 A.304		2	2	2	
2	Z200551000	ASA PUERTA		1	1	1	
3	Z268005000	PUERTA SOLDADA		1	1	1	
4	Z200506000	IMAN		1	1	1	
5	Z200507000	PROTECTOR IMAN		1	1	1	
6	Z400514000	BISAGRA IZQUIERDA T-C.		1	1	1	
	Q012042000	TORNIL. EXAGONAL M6X15 A.304		2	2	2	
	Q232040000	ARANDELA A6		2	2	2	
	Q262040000	ARANDELA GROW. A6 A.304		2	2	2	
	Q162040000	TUERCA EXAGONAL M6		1	1	1	
S/Nº	Z400515000	BISAGRA DERECHA T-C.		1	1	1	
	Q012042000	TORNIL. EXAGONAL M6X15 A.304		2	2	2	
	Q232040000	ARANDELA A6		2	2	2	
	Q262040000	ARANDELA GROW. A6 A.304		2	2	2	
	Q162040000	TUERCA EXAGONAL M6		1	1	1	
7	Z400516000	EJE PUERTA		2	2	2	
8	Z260508000	MARCO PUERTA		2	2	2	
	Q412000000	REMACHE TUBULAR 4 x 8		6	6	6	
	Q032041000	TORNILLO ALOMADO M6X10		2	2	2	
	Q308002000	ARANDELA DUBO A6 NYLON		2	2	2	
9	Z260506000	VARILLA TENSOR		1	1	1	
10	Z200310000	SOPORTE TENSOR		2	2	2	
11	Z200522000	TENSOR PUERTA		2	2	2	
12	Q222012000	TUERCA AUTOB. M6		2	2	2	

Зип Общепит

MOD. LAVAVAJILLAS DE APERTURA FRONTAL

ZONA

PUERTA

ITEM	CODIGO	DENOMINACION	TEXTO	+7(812)987-08-81				
				FI-72	FI-72 A.R	FI-72 W		
13	Q162030000	TUERCA EXAGONAL M5		4	4	4		
	Q152004000	TORNIL, APLASTADO M5x13 A304		4	4	4		
	Q232030000	ARANDELA A5		4	4	4		
	Q262030000	ARANDELA GROW. A5 A.304		4	4	4		
14	Q222012000	TUERCA AUTOB. M6		4	4	4		
15	Z200607000	CONJUNTO CIERRE PUER.T-CO		2	2	2		
16	Z200601000	ENGANCHE CIERRE		2	2	2		
	Q232030000	ARANDELA A5		2	2	2		

Зип Общепит

vsezip.ru

+7(812)987-08-81

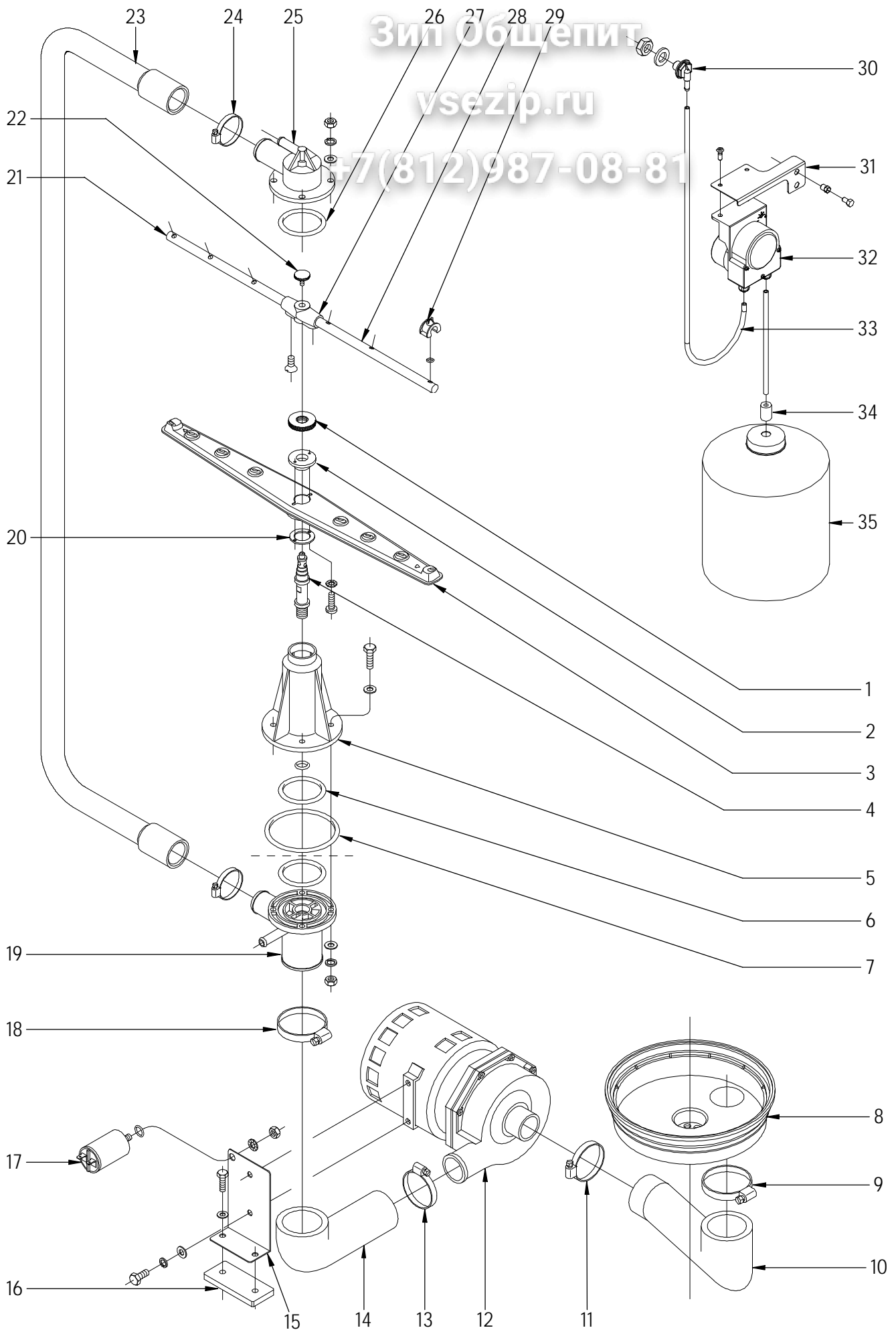

N plano	Firma	Fecha	Aparato	PARTE FUNCIONAL DE LAVADO	Lamina	Fagor Industrial S.Coop. FAGOR
C-1859	<i>[Signature]</i>	2007-06	LAVAVAVAJILLAS FI-72		3	Onote

Зип Общепит

MOD. LAVAVAJILLAS DE APERTURA FRONTAL

ZONA

PARTE FUNCIONAL LAVADO

ITEM	CODIGO	DENOMINACION	TEXTO	FI-72	FI-72 A.R	FI-72 W	
1	Z200705000	TUERCA ESPECIAL M.14X1		2	2	2	
2	Z650704000	ENGANCHE DISTRIBUIDOR		2	2	2	
3	Z650716000	DISTRIBUIDOR MONTADO		2	2	2	
4	Z200704000	EJE CENTRAL		2	2	2	
5	Z200701000	SOPORTE DISTRIBUID. INFERIOR		1	1	1	
	Q307050000	JUNTA TOR.13.94X19.18X2.6		1	1	1	
	Q012046000	TORNIL. EXAGONAL M6X40 A.304		4	4	4	
	Q306050000	ARANDELA Ø6X12X1.5		4	4	4	
6	Q307052000	JUNTA TOR.50.17X60.83X5.3		2	2	2	
7	Q307049000	JUNTA TOR.85.09X95.75X5.3		1	1	1	
8	Z200906000	CUBETA		1	1	1	
9	Q881324000	ABRAZADERA 50-70L		1	1	1	
10	Z200904000	CODO ASPIRACION 1003018		1	1	1	
11	Q881307000	ABRAZADERA 40-60		1	1	1	
12	Z201011000	BOMBA DE LAVADO		1	1	1	
12	Z203511000	BOMBA DE LAVADO 60 HZ.		1	1	1	
	Z203601000	RESISTENCIA TANQUE		1	1	1	
13	Q881307000	ABRAZADERA 40-60		1	1	1	
14	Z200905000	CODO IMPULSION 1003017		1	1	1	
15	Z261001000	SOPORTE MOTOBOMBA FI-72		1	1	1	
	Q012041000	TORNIL. EXAGONAL M6X10 A.304		2	2	2	
	Q232040000	ARANDELA A6		2	2	2	
	Q262040000	ARANDELA GROW. A6 A.304		2	2	2	
16	Z201003000	BASE BOMBA LAVADO 1003016		1	1	1	
	Q012033000	TORNIL. EXAGONAL M5X20 A.304		2	2	2	
	Q232030000	ARANDELA A5		2	2	2	
17	V321300000	CONDENSADOR 10 M.F.		1	1	1	
	Q307048000	JUNTA TORICA 9.12X16.18X3.53		1	1	1	
	Q162050000	TUERCA EXAGONAL M8x1 INOX.		1	1	1	
	Q261050000	ARANDELA MUELLE A8		1	1	1	

MOD. LAVAVAJILLAS DE APERTURA FRONTAL

ZONA

PARTE FUNCIONAL LAVADO

ITEM	CODIGO	DENOMINACION	TEXTO	FI-72	FI-72 A.R	FI-72 W	
18	Q881324000	ABRAZADERA 50-70L		1	1	1	
19	Z200703000	PASAMUROS		1	1	1	
	Q232040000	ARANDELA A6		4	4	4	
	Q262040000	ARANDELA GROW. A6 A.304		4	4	4	
	Q162040000	TUERCA EXAGONAL M6		4	4	4	
20	Z650711000	AMARRE ENGANCHE DISTRIBUID.		2	2	2	
	Q152015000	TORNILLO ALOMADO M3X6		4	4	4	
	Q242010000	ARANDELA ABANICO A.3 A304		4	4	4	
21	Z201902000	RAMA DE ACLARADO IZQUIERDA		2	2	2	
22	Q152016000	TORNILLO ESPECIAL M.5X0.8		2	2	2	
23	Z260701000	ARBOL DE LAVADO		1	1	1	
24	Q881305000	ABRAZADERA 25-40		2	2	2	
25	Z200707000	SOPORTE DISTRIBUIDOR SUPER.		1	1	1	
	Q232040000	ARANDELA A6		4	4	4	
	Q262040000	ARANDELA GROW. A6 A.304		4	4	4	
	Q162040000	TUERCA EXAGONAL M6		4	4	4	
26	Q307052000	JUNTA TOR.50.17X60.83X5.3		1	1	1	
27	Z201903000	SOPORTE RAMAS ACLARADO		2	2	2	
	Q042021000	TORN. AVELLANADO M4X10 A.304		4	4	4	
28	Z201901000	RAMA DE ACLARADO DERECHA		2	2	2	
29	Z211903000	TOBERA ACLARADO		12	12	12	
30	Z230902000	PASAMUROS DETERGENTE		-	-	1	
	Q306024000	JUNTA Ø18X12.5X1.5		-	-	2	
	Q162070000	TUERCA EXAGONAL M12		-	-	2	
31	Z208434000	SOPORTE DOSIFICADOR W		-	-	1	
	Q411304000	REMACHE AVIBULB Ø4,8		-	-	2	
	Q221342000	REMACHE EXAGONAL M5		-	-	2	
	Q012031000	TORNIL. EXAGONAL M5X10 A.304		-	-	2	
	Q232030000	ARANDELA A5		-	-	2	
	Q162030000	TUERCA EXAGONAL M5		-	-	2	

Зип Ощепит

MOD. LAVAVAJILLAS DE APERTURA FRONTAL

ZONA

PARTE FUNCIONAL LAVADO

+7(812)987-08-81

ITEM	CODIGO	DENOMINACION	TEXTO	FI-72	FI-72 A.R	FI-72 W	
32	Z208903000	DOSIFIC. DGTE REGULABLE G300				1	
33	Z448614000	CONDUCTO ASPIRACIÓN				1	
S/Nº	Z448616000	PEGATINA TOMA DETERGENTE				1	
34	Z701152000	PESO FILTRO				1	
35	-	GARRAFA DETERGENTE				1	
S/Nº	Z208904000	CABLEADO DOSIFICADOR DTGTE				1	

Зип Общежит

vsezip.ru

+7(812)987-08-81

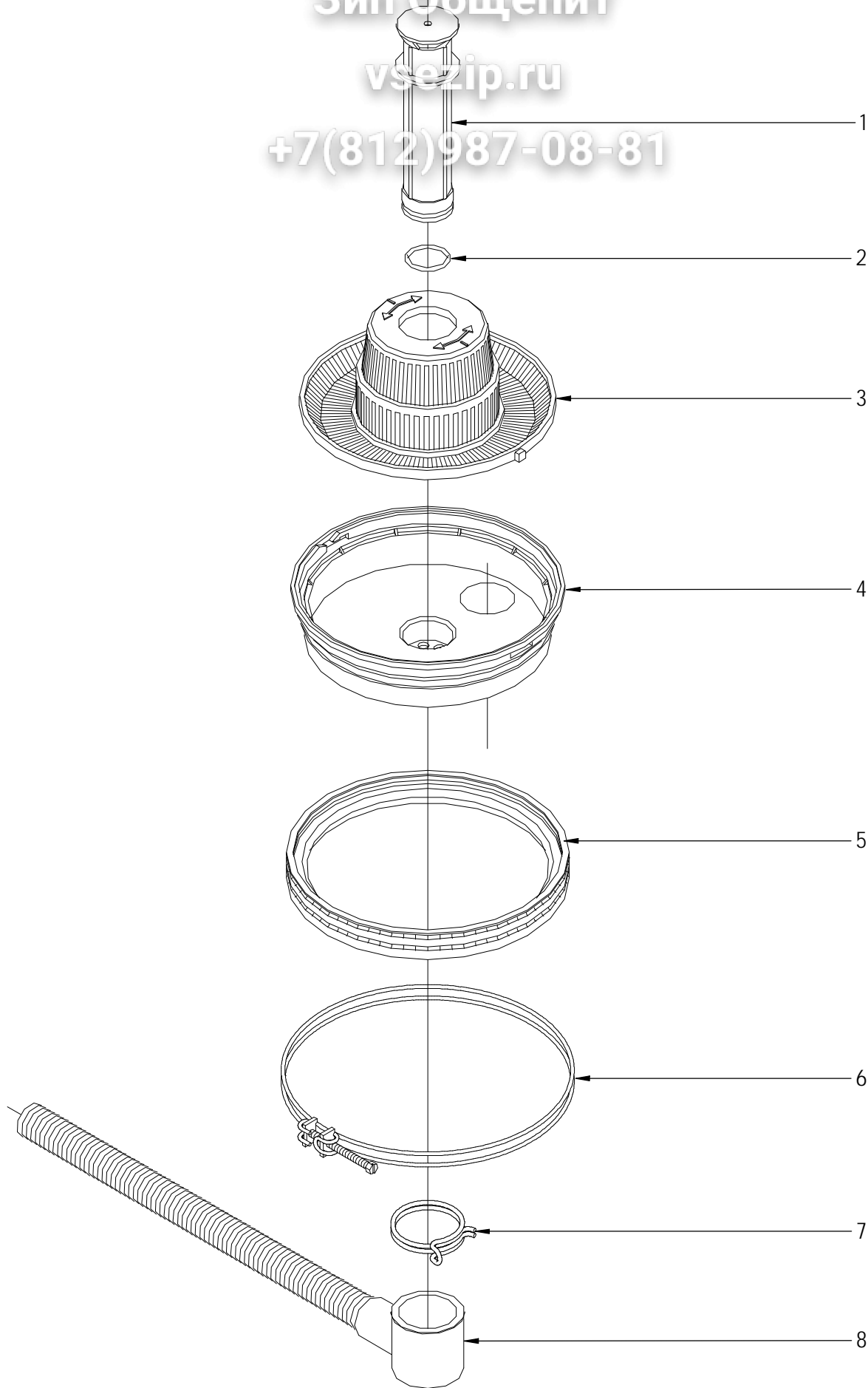

N plano	Firma	Fecha	Aparato	PARTE FUNCIONAL DESAGUE	Lamina	Fagor Industrial S.Coop. FAGOR
C-1860	<i>[Signature]</i>	2007-06	LAVAVAJILLAS FI-72		4	Oñate

Зип Общепит

MOD. LAVAVAJILLAS DE APERTURA FRONTAL

ZONA

PARTE FUNCIONAL DESAGÜE

+7(812)987-08-81

ITEM	CODIGO	DENOMINACION	TEXTO	FI-72	FI-72 A.R	FI-72 W	
1	Z200909000	ALIVIADERO		1	1	1	
2	Q307051000	JUNTA TOR.36.17X41.41X2.6		1	1	1	
3	Z200922000	CONJUNTO FILTRO AF.		1	1	1	
4	Z200906000	CUBETA		1	1	1	
5	Z200907000	JUNTA CUBETA		1	1	1	
6	Z200908000	ABRAZADERA CUBETA COMPL.		1	1	1	
7	Q901308000	ABRAZAD. ELAST. 56-58.8		1	1	1	
8	Z200910000	MANGUERA DESAGUE		1	1	1	
	X763020000	BRIDA CREMALLERA		-	-	1	

Зип Общепит

vsezip.ru

+7(812)987-08-81

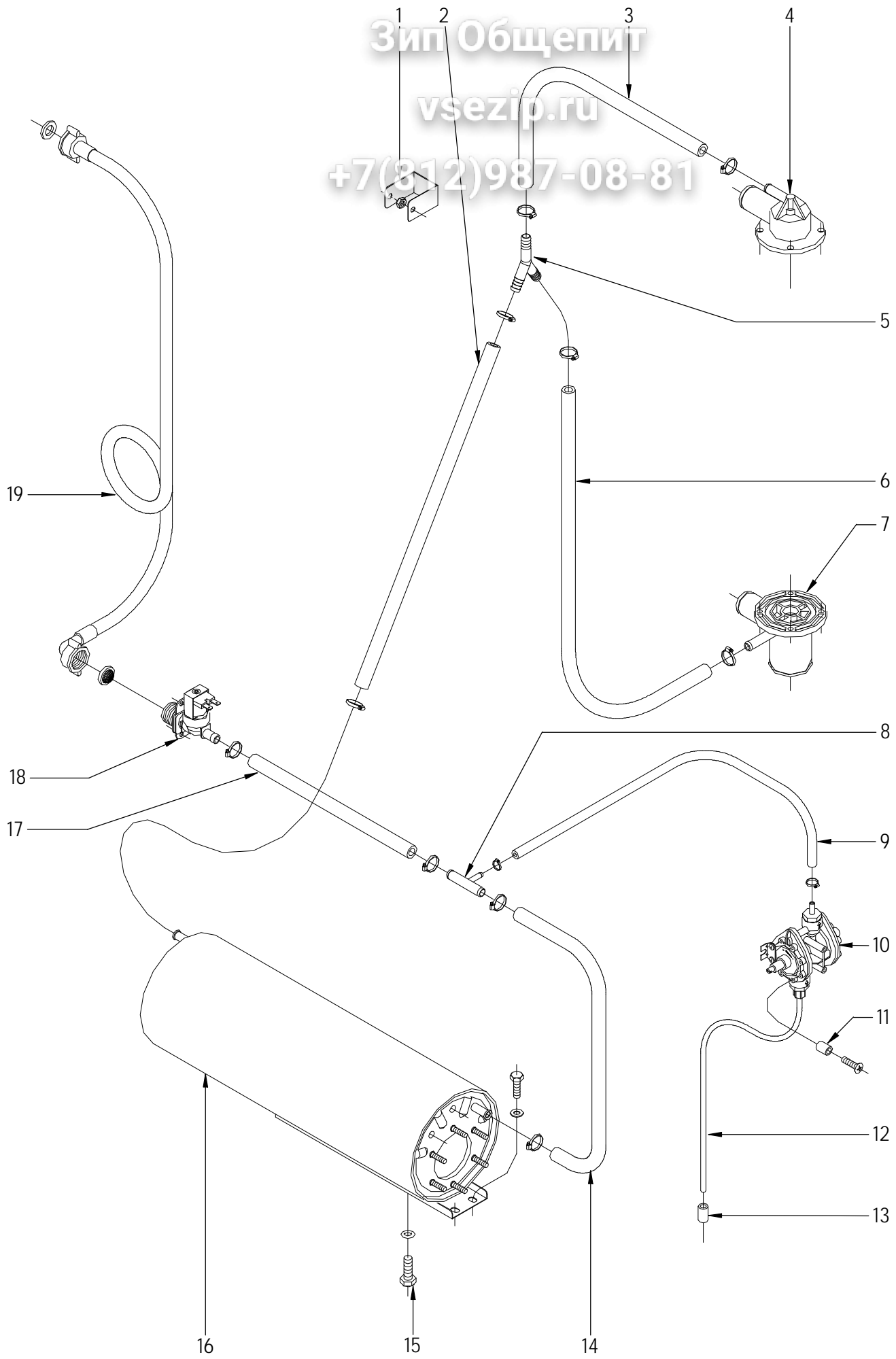

N plano	Firma	Fecha	Aparato	PARTE FUNCIONAL ACLARADO	Lamina	Fagor Industrial S.Coop. FAGOR
C-1861	<i>[Signature]</i>	2007-06	LAVAVAJILLAS FI-72		5	Oñate

Зип Общепит

MOD. LAVAVAJILLAS DE APERTURA FRONTAL

ZONA

PARTE FUNCIONAL ACLARADO

ITEM	CODIGO	DENOMINACION	TEXTO	FI-72			
1	R722631000	FIJACION ALERON		1			
	Q162040000	TUERCA EXAGONAL M6		1			
2	3676900000	TUBO GOMA NEGRA Ø 17*10		1			
	Q881302000	ABRAZADERA 12-20		2			
3	3676900000	TUBO GOMA NEGRA Ø 17*10		1			
	Q881302000	ABRAZADERA 12-20		2			
4	Z200707000	SOPORTE DISTRIB. SUPERIOR		1			
5	Z201106000	RACORD EN Y		1			
6	3676900000	TUBO GOMA NEGRA Ø 17*10		1			
	Q881302000	ABRAZADERA 12-20		2			
7	Z200703000	PASAMUROS		1			
8	Z601157000	TOMA PRESION		1			
9	3704000000	TUBO GOMA NEGRO D 10,5*5		1			
	Q881308000	ABRAZADERA 8-14L		2			
10	Z651123000	DOSIFICADOR TENSOACTIVO		1			
11	Z203007000	CASQUILLO		2			
	Q041324000	TORN. AVELLA. M4x25 H.ZINCADO		2			
12	Z448614000	CONDUCTO ASPIRACION		1			
13	Z701152000	PESO FILTRO		1			
14	3676900000	TUBO GOMA NEGRA Ø 17*10		1			
	Q881302000	ABRAZADERA 12-20		2			
15	Q012063000	TORNIL. EXAGONAL M10x20 A.304		1			
	Q307048000	JUNTA TORICA Ø9.12X16.18X3.53		1			
16	Z201710000	CALDERIN COMPLETO		1			
	Q012031000	TORNIL. EXAGONAL M5x10 A.304		2			
	Q232030000	ARANDELA A5		2			
17	3676900000	TUBO GOMA NEGRA Ø 17*10		1			
	Q881302000	ABRAZADERA 12-20		2			
18	Z701135000	ELECTR. SIMP.220V COD.255.208		1			
	Q152024000	TORN. AVELLANADO M4x8 A.304		2			
19	Z602121000	MANGUERA ENTRADA AGUA		1			

Зип Общепит

vsezip.ru

+7(812)987-08-81

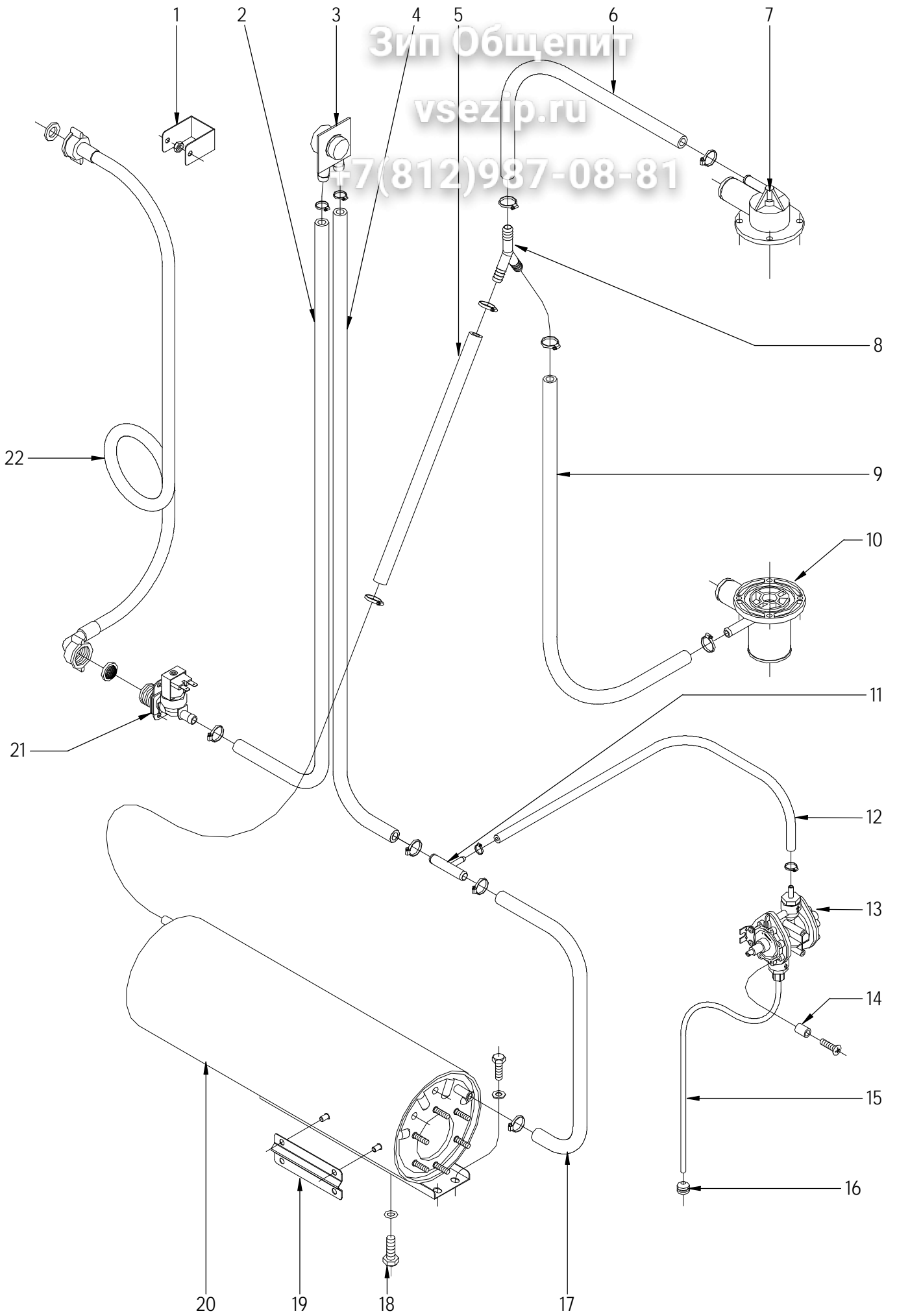

N plano	Firma	Fecha	Aparato	PARTE FUNCIONAL ACLARADO	Lamina	Fagor Industrial S.Coop. FAGOR
C-1862	<i>[Signature]</i>	2007-06	LAVAVAJILLAS FI-72 AR; FI-72 W		6	Oñate

Зип Общепит

MOD. LAVAVAJILLAS DE APERTURA FRONTAL

ZONA

PARTE FUNCIONAL ACLARADO

ITEM	CODIGO	DENOMINACION	TEXTO	FI-72 AR	FI-72 W		
1	R722631000	FIJACION ALERON		1	1		
	Q162040000	TUERCA EXAGONAL M6		1	1		
2	3676900000	TUBO GOMA NEGRA Ø 17*10		1	1		
	Q881302000	ABRAZADERA 12-20		2	2		
3	Z231106000	VALVULA ANTIRRETORNO		1	1		
4	3676900000	TUBO GOMA NEGRA Ø 17*10		1	1		
	Q881302000	ABRAZADERA 12-20		2	2		
5	3676900000	TUBO GOMA NEGRA Ø 17*10		1	1		
	Q881302000	ABRAZADERA 12-20		2	2		
6	3676900000	TUBO GOMA NEGRA Ø 17*10		1	1		
	Q881302000	ABRAZADERA 12-20		2	2		
7	Z200707000	SOPORTE DISTRIB. SUPERIOR		1	1		
8	Z201106000	RACORD EN Y		1	1		
9	3676900000	TUBO GOMA NEGRA Ø 17*10		1	1		
	Q881302000	ABRAZADERA 12-20		2	2		
10	Z200703000	PASAMUROS		1	1		
11	Z601157000	TOMA PRESION		1	1		
12	3704000000	TUBO GOMA NEGRO D 10,5*5		1	1		
	Q881308000	ABRAZADERA 8-14L		2	2		
13	Z651123000	DOSIFICADOR TENSOACTIVO		1	1		
14	Z203007000	CASQUILLO		2	2		
	Q041324000	TORN. AVELLA. M4x25 H.ZINCADO		2	2		
15	Z448614000	CONDUCTO ASPIRACIÓN		1	1		
16	Z701152000	PESO FILTRO		1	1		
17	3676900000	TUBO GOMA NEGRA Ø 17*10		1	1		
	Q881302000	ABRAZADERA 12-20		2	2		
18	Q012063000	TORNIL. EXAGONAL M10x20 A.304		1	1		
	Q307048000	JUNTA TORICA Ø9.12X16.18X3.53		1	1		

Зип Общепит

MOD. LAVAVAJILLAS DE APERTURA FRONTAL

ZONA

PARTE FUNCIONAL ACLARADO

ITEM	CODIGO	DENOMINACION	TEXTO	FI-72 AR	FI-72 W		
19	Z748008000	SOPORTE BULBO TERMOSTATO			1		
	Q162040000	TUERCA EXAGONAL M6			2		
	Q232040000	ARANDELA A6			2		
	Q262040000	ARANDELA GROW. A6 A.304			2		
20	Z201710000	CALDERIN COMPLETO		1	1		
	Q012031000	TORNIL. EXAGONAL M5x10 A.304		2	2		
	Q232030000	ARANDELA A5		2	2		
	Q152018000	PERNO M6x10			2		
21	Z701135000	ELECTR. SIMP.220V COD.255.208		1	1		
	Q152024000	TORN. AVELLANADO M4x8 A.304		2	2		
22	Z602121000	MANGUERA ENTRADA AGUA		1	1		

Зип Общепит

vsezip.ru

+7(812)987-08-81

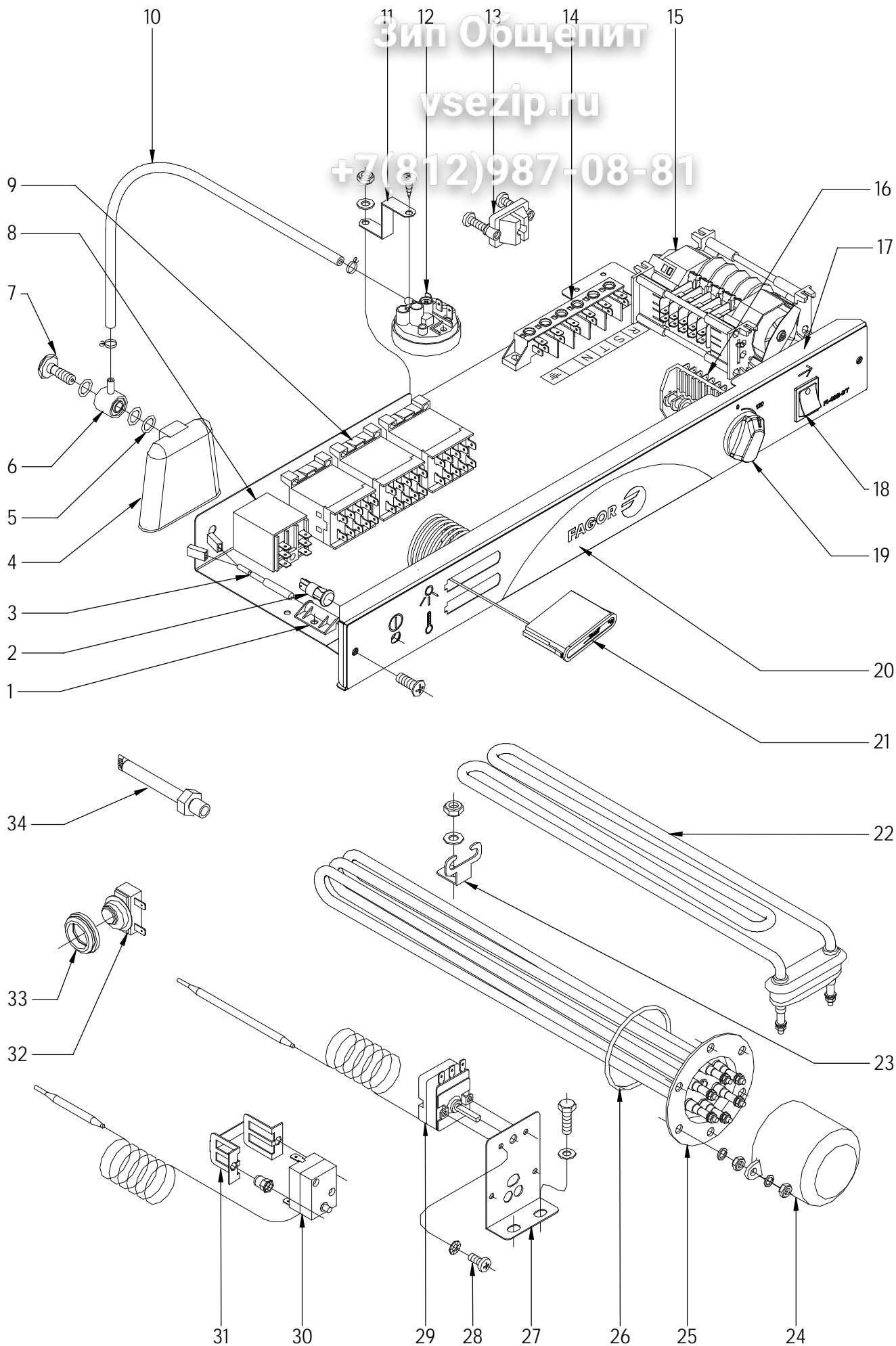

N plano	Firma	Fecha	Aparato	PARTE FUNCIONAL ELECTRICA	Lamina	Fagor Industrial S.Coop. FAGOR
C-1863	<i>[Signature]</i>	2007-06	LAVAVAJILLAS FI-72		7	Onote

Зип Общепит

MOD. LAVAVAJILLAS DE APERTURA FRONTAL

ZONA

PARTE FUNCIONAL ELECTRICA

ITEM	CODIGO	DENOMINACION	TEXTO	FI-72	FI-72 AR		
1	Z203010000	AMARRE INTERRUPT. MAGNETICO		1	1		
	Q152004000	TORNIL, APLASTADO M5x13 A304		1	1		
	Q232030000	ARANDELA A5		1	1		
	Q162030000	TUERCA EXAGONAL M5		1	1		
2	R693056000	PILOTO AMBAR 41227000A4		1	1		
3	Z203009000	INTERRUPTOR MAGNETICO		1	1		
4	Z203011000	CAMARA PRESOSTATO		1	1		
5	Q307003000	JUNTA TORICA 16.01X10.77X2.62		3	3		
6	Z203012000	EMPALME PRESOSTATO		1	1		
7	Z203013000	TORNILLO PRESOSTATO		1	1		
8	Z203062000	RELE 230V. 16A 50-60 HZ		1	1		
	Q162050000	TUERCA EXAGONAL M8x1 INOX.		1	1		
	Q261050000	ARANDELA MUELLE A8		1	1		
9	Z213007000	CONTACTOR 230 V. 50-60 HZ		3	3		
10	3702400000	TUBO GOMA NEGRO Ø 8*4		1	1		
	P102154000	BRIDA ELASTICA TUBO		2	2		
11	Z602923000	SOPORTE PRESOSTATO		1	1		
	Q082032000	TORNILLO ALOMADO BZ-3,5X9,5		1	1		
	Q152004000	TORNILLO APLASTADO M5x13		1	1		
	Q232030000	ARANDELA A5		1	1		
	Q162030000	TUERCA EXAGONAL M5		1	1		
12	Z203023000	PRESOSTATO SIMPLE PVS		1	1		
13	Z203020000	RETENEDOR DE CABLE		1	1		
14	R253044000	REGLETA AUXILIAR FV-122		1	1		
	Z213005000	ROTULO ADHESIVO		1	1		
	Q152004000	TORNILLO APLASTADO M5x13		2	2		
	Q232030000	ARANDELA A5		2	2		
	Q162030000	TUERCA EXAGONAL M5		2	2		

Зип Общепит

MOD.

LAVAVAJILLAS DE APERTURA FRONTAL

ZONA

PARTE FUNCIONAL ELECTRICA

ITEM	CODIGO	DENOMINACION	TEXTO	FI-72	FI-72 AR		
15	Z243004000	PROGRAMADOR CICLO		1	1		
	Q032021000	TORNILLO ALOMADO M4x10		2	2		
	Q162020000	TUERCA EXAGONAL M4		2	2		
	Z203007000	CASQUILLO		2	2		
	Q041324000	TORN. AVELLA. M4x25 H.ZINCADO		2	2		
16	Z213003000	CONMUTADOR DE FUNCIONES		1	1		
17	Z202918000	FRENTE COMPLETO		1	1		
	Q152004000	TORNILLO APLASTADO M5x13		2	2		
	3713500000	PERFIL CUBREARISTAS PLASTICO		1	1		
18	Z203080000	PULSADOR MARCHA NEGRO		1	1		
19	Z203069000	BOTON DE MANDO		1	1		
20	Z262907000	EMBELLECEDOR ADHESIVO FI-72		1	1		
21	Z203072000	INDICADOR ANALOGICO		2	2		
22	Z203601000	RESISTENCIA TANQUE		1	1		
23	Z603602000	SOPORTE RESISTENCIA TANQUE		1	1		
	Q232040000	ARANDELA A6		1	1		
	Q162040000	TUERCA EXAGONAL M6		1	1		
24	Z651731000	CAPERUZA RESISTEN. CALDERIN		1	1		
	Q163140000	TUERCA EXAGONAL M6 LATON		2	2		
	Q012031000	TORNIL. EXAGONAL M5x10 A.304		2	2		
	Q232030000	ARANDELA A5		2	2		
	Q012063000	TORNIL. EXAGONAL M10x20 A.304		2	2		
25	Z241701000	RESISTENCIA CALDERIN		1	1		
	Q221305000	TUERCA EX.AUTO M4 ZINCADA		6	6		
	Q163140000	TUERCA EXAGONAL M6 LATON		6	6		
	Q262040000	ARANDELA GROW. A6 A.304		6	6		
26	Q307048000	JUNTA TORICA 9.12x16.18x3.53		1	1		
27	Z203047000	SOPORTE TERMOSTATOS		1	1		
	Q012031000	TORNIL. EXAGONAL M5X10 A.304		2	2		
	Q232030000	ARANDELA A5		2	2		
28	Q152024000	TORNIL. AVELLANADO M4X8 A304		2	2		

Зип Общепит

MOD. LAVAVAJILLAS DE APERTURA FRONTAL ZONA PARTE FUNCIONAL ELECTRICA

ITEM	CODIGO	DENOMINACION	TEXTO	FI-72	FI-72 AR		
29	Z203014000	TERMOSTATO CALDERIN		1	1		
30	Z213014000	LIMITADOR TECASA P.		1	1		
31	Z203060000	AMARRE LIMITADOR TECASA		1	1		
	Q221341000	REMACHE EXAGONAL M4		2	2		
	Q152024000	TORNIL. AVELLANADO M4X8 A304		2	2		
32	Z718405000	TERMOSTATO DOBLE		1	1		
33	N503017000	SOPORTE TERMOSTATO 1001713		1	1		
34	Z263002000	VAINA INDICADOR COMPLETA		1	1		
	Q306024000	JUNTA TORICA 18x12,5x1,5		1	1		
	Q162070000	TUERCA EXAGONAL M12		1	1		

Зип Общепит

vsezip.ru

+7(812)987-08-81

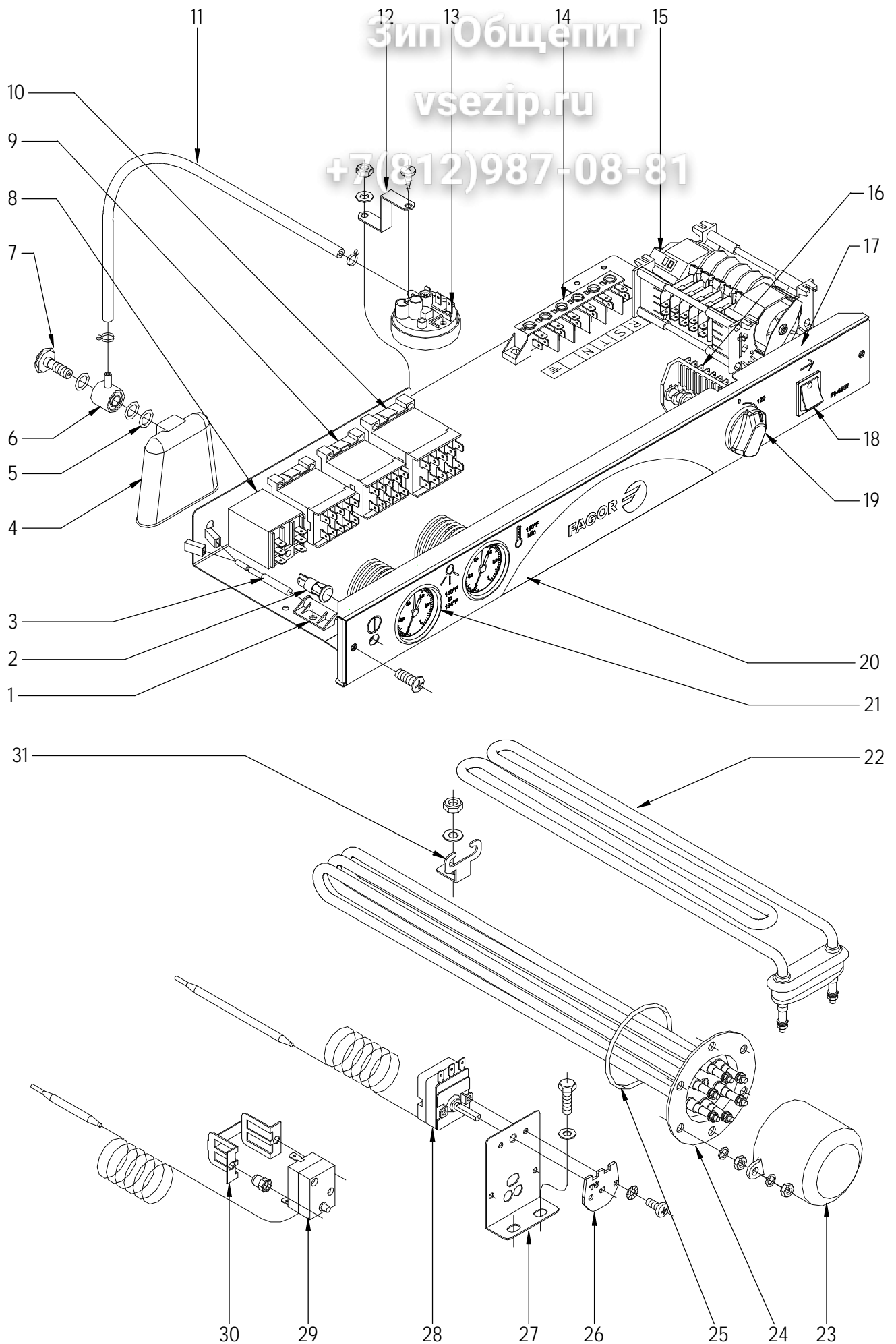

N plano	Firma	Fecha	Aparato	PARTE FUNCIONAL ELECTRICA	Lamina	Fagor Industrial S.Coop. FAGOR
C-1864	<i>[Signature]</i>	2007-06	LAVAVAJILLAS FI-72 W	8	Onote	

Зип Общепит

MOD. LAVAVAJILLAS DE APERTURA FRONTAL

ZONA

PARTE FUNCIONAL ELECTRICA

ITEM	CODIGO	DENOMINACION	TEXTO	FI-72 W			
1	Z203010000	AMARRE INTERRUPT. MAGNETICO		1			
	Q152004000	TORNIL, APLASTADO M5x13 A304		1			
	Q232030000	ARANDELA A5		1			
	Q162030000	TUERCA EXAGONAL M5		1			
2	R693056000	PILOTO AMBAR 41227000A4		1			
3	Z203009000	INTERRUPTOR MAGNETICO		1			
4	Z203011000	CAMARA PRESOSTATO		1			
5	Q307003000	JUNTA TORICA 16.01X10.77X2.62		3			
6	Z203012000	EMPALME PRESOSTATO		1			
7	Z203013000	TORNILLO PRESOSTATO		1			
8	Z203062000	RELE 230V. 16A 50-60 HZ		1			
	Q162050000	TUERCA EXAGONAL M8x1 INOX.		1			
	Q261050000	ARANDELA MUELLE A8		1			
9	Z213007000	CONTACTOR 230 V. 50-60 HZ		2			
10	Z683087000	CONTACTOR 3TF20 01-3AL2 230		1			
	Q032021000	TORNILLO ALOMADO M4x10		2			
	Q162020000	TUERCA EXAGONAL M4		2			
11	3702400000	TUBO GOMA NEGRO Ø 8*4		1			
	P102154000	BRIDA ELASTICA TUBO		2			
12	Z602923000	SOPORTE PRESOSTATO		1			
	Q082032000	TORNILLO ALOMADO BZ-3,5X9,5		1			
	Q152004000	TORNILLO APLASTADO M5x13		1			
	Q232030000	ARANDELA A5		1			
	Q162030000	TUERCA EXAGONAL M5		1			
13	Z203023000	PRESOSTATO SIMPLE PVS		1			
14	R253044000	REGLETA AUXILIAR FV-122		1			
	Z213005000	ROTULO ADHESIVO		1			
	Q152004000	TORNILLO APLASTADO M5x13		2			
	Q232030000	ARANDELA A5		2			
	Q162030000	TUERCA EXAGONAL M5		2			

Зип Общепит

MOD. LAVAVAJILLAS DE APERTURA FRONTAL

ZONA

PARTE FUNCIONAL ELECTRICA

ITEM	CODIGO	DENOMINACION	TEXTO	FI-72 W			
15	Z258412000	PROGRAMADOR 60HZ.T.STOP		1			
16	Z213003000	CONMUTADOR DE FUNCIONES		1			
	Z203007000	CASQUILLO		2			
	Q041324000	TORN. AVELLA. M4x25 H.ZINCADO		2			
17	Z208908000	FRENTE COMPLETO AF W		1			
	Q152004000	TORNILLO APLASTADO M5x13		2			
	3713500000	PERFIL CUBREARISTAS PLASTICO		1			
18	Z203080000	PULSADOR MARCHA NEGRO		1			
	Q032021000	TORNILLO ALOMADO M4x10		2			
	Q162020000	TUERCA EXAGONAL M4		2			
19	Z203069000	BOTON DE MANDO		1			
20	Z268901000	EMBELLECEDOR ADHES. FI-72 W		1			
21	Z273060000	TERMOMETRO W NSF		2			
22	Z203601000	RESISTENCIA TANQUE		1			
23	Z651731000	CAPERUZA RESISTEN. CALDERIN		1			
	Q163140000	TUERCA EXAGONAL M6 LATON		2			
	Q012031000	TORNIL. EXAGONAL M5x10 A.304		2			
	Q232030000	ARANDELA A5		2			
24	Z241703000	RESISTENCIA W CALDERIN		1			
	Q221305000	TUERCA EX.AUTO M4 ZINCADA		6			
	Q163140000	TUERCA EXAGONAL M6 LATON		6			
	Q262040000	ARANDELA GROW. A6 A.304		6			
25	Q307035000	JUNTA TORICA AN-36 282333		1			
26	Z208438000	CHAPA W TC 90°C		1			
27	Z203047000	SOPORTE TERMOSTATOS		1			
	Q012031000	TORNIL. EXAGONAL M5X10 A.304		2			
	Q232030000	ARANDELA A5		2			
	Q152024000	TORNIL. AVELLANADO M4X8 A304		6			
28	Z203014000	TERMOSTATO CALDERIN		3			
29	Z213014000	LIMITADOR TECASA P.		1			

MOD. LAVAVAJILLAS DE APERTURA FRONTAL ZONA PARTE FUNCIONAL ELECTRICA

ITEM	CODIGO	DENOMINACION	TEXTO	FI-72 W			
30	Z203060000	AMARRE LIMITADOR TECASA		1			
	Q221341000	REMACHE EXAGONAL M4		2			
	Q152024000	TORNIL. AVELLANADO M4X8 A304		2			
31	Z603602000	SOPORTE RESISTENCIA TANQUE		1			
	Q232040000	ARANDELA A6		1			
	Q162040000	TUERCA EXAGONAL M6		1			

Зип Общепит

vsezip.ru

+7(812)987-08-81

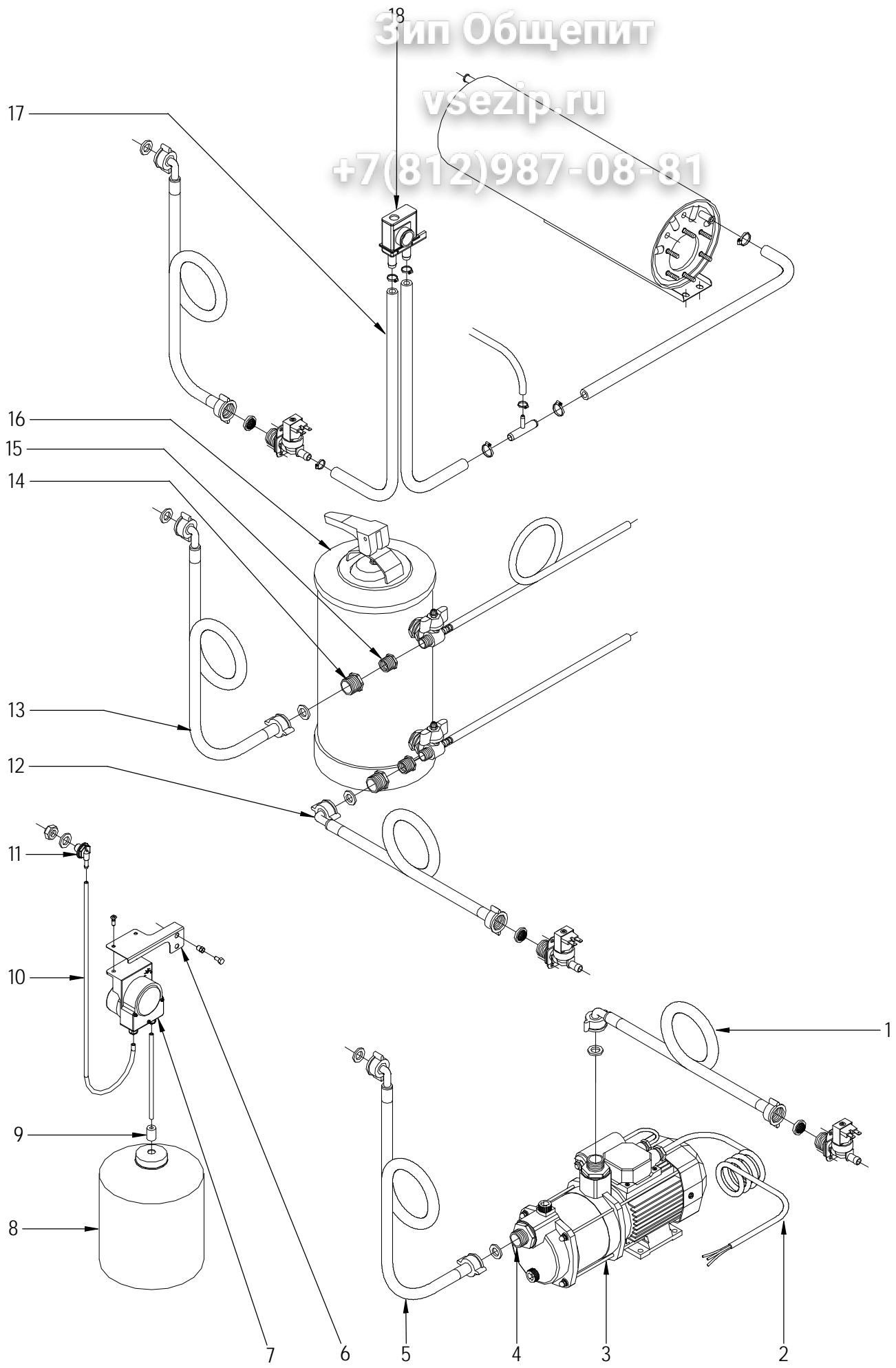

N plano	Firma	Fecha	Aparato	ACCESORIOS	Lamina	Fagor Industrial S.Coop. FAGOR
C-1865	<i>[Signature]</i>	2007-06	LAVAVAJILLAS FI-72		9	Oñate

MOD. LAVAVAJILLAS DE APERTURA FRONTAL

ZONA

ACCESORIOS PARA LAVAVAJILLA

ITEM	CODIGO	DENOMINACION	TEXTO	FI-72				
120000125 KIT BOMBA PRESION								
1	-	MANGUERA DE MAQUINA		-				
2	Z209510000	CABLEADO BOMBA PRESION		1				
3	Z209508000	BOMBA PRESION PRISMA 15		1				
4	Z209509000	MANGUITO		2				
5	Z602121000	MANGUERA ENTRADA AGUA		1				
	Q306037000	ARANDELA Ø42.5X32X1.5		2				
120000132 KIT DOSIFICADOR DETERGENTE								
6	Z208434000	SOPORTE DOSIFICADOR W		1				
	Q411304000	REMACHE AVIBULB Ø4,8		2				
	Q221342000	REMACHE EXAGONAL M5		2				
	Q012031000	TORNIL. EXAGONAL M5X10 A.304		2				
	Q232030000	ARANDELA A5		2				
	Q162030000	TUERCA EXAGONAL M5		2				
7	Z208903000	DOSIFIC. DGTE REGULABLE G300		1				
8	-	GARRAFA DETERGENTE		1				
9	Z701152000	PESO FILTRO		1				
10	Z448614000	CONDUCTO ASPIRACION		1				
11	Z230902000	PASAMUROS DETERGENTE		1				
	Q306024000	JUNTA Ø18X12.5X1.5		1				
	Q162070000	TUERCA EXAGONAL M12		1				
S/Nº	Z208904000	CABLEADO DOSIFICADOR DTGTE		1				

MOD.

LAVAVAJILLAS DE APERTURA FRONTAL ZONA

ACCESORIOS PARA LAVAVAJILLA

ITEM	CODIGO	DENOMINACION	TEXTO	FI-72				
<u>1200000128 KIT DESCALCIFICADOR 12 L</u>								
12	-	MANGUERA DE MAQUINA		.				
13	Z602121000	MANGUERA ENTRADA AGUA		1				
14	Z209515000	TUERCA REDUCCION 3/4" - 1/2"		2				
15	Z209516000	TUERCA REDUCCION 1/2" - 3/8"		2				
16	Z209507000	DESCALCIFICADOR DE 12 L		1				
<u>1200000130 KIT VALVULA ANTIRRETORNO</u>								
17	3676900000	TUBO DE GOMA NEGRA Ø17x10		2				
	Q881302000	ABRAZADERA 12 - 20		2				
18	Z231106000	VALVULA ANTIRRETORNO		1				

Зип Общепит

MOD.	LAVAVAJILLAS DE APERTURA FRONTAL	ZONA	VARIOS
------	----------------------------------	------	--------

ITEM	CODIGO	DENOMINACION	TEXTO	FI-72	FI-72 W		
	Z246131000	FOLLETO DE INSTRUCCIONES		1			
	Z208432000	FOLLETO INSTRUCCIONES W			1		
	Z243049000	ESQUEMA TEORICO FI-72		1			
	Z263005000	ESQUEMA TEORICO FI-72 W			1		
	Z243050000	PLANO DE MONTAJE FI-74		1			
	Z263006000	PLANO DE MONTAJE FI-72 W			1		
	Z243048000	CABLEADO		1	1		
	Z243047000	CABLEADO TERMO STOP FI-64W			1		
	Z208436000	CABLEADO PROLONG. TSTOP			1		
	Z243046000	INSTALACION ELECTRICA FI-64		1	1		

FI-64, FI-72, KM-64, MLV-50 T

Зип.Общепит
vsezip.ru
+7(812)987-08-81

380 - 415 V. 3NPh

200-220-240 V. 3Ph

200-220-240 V. 1Ph

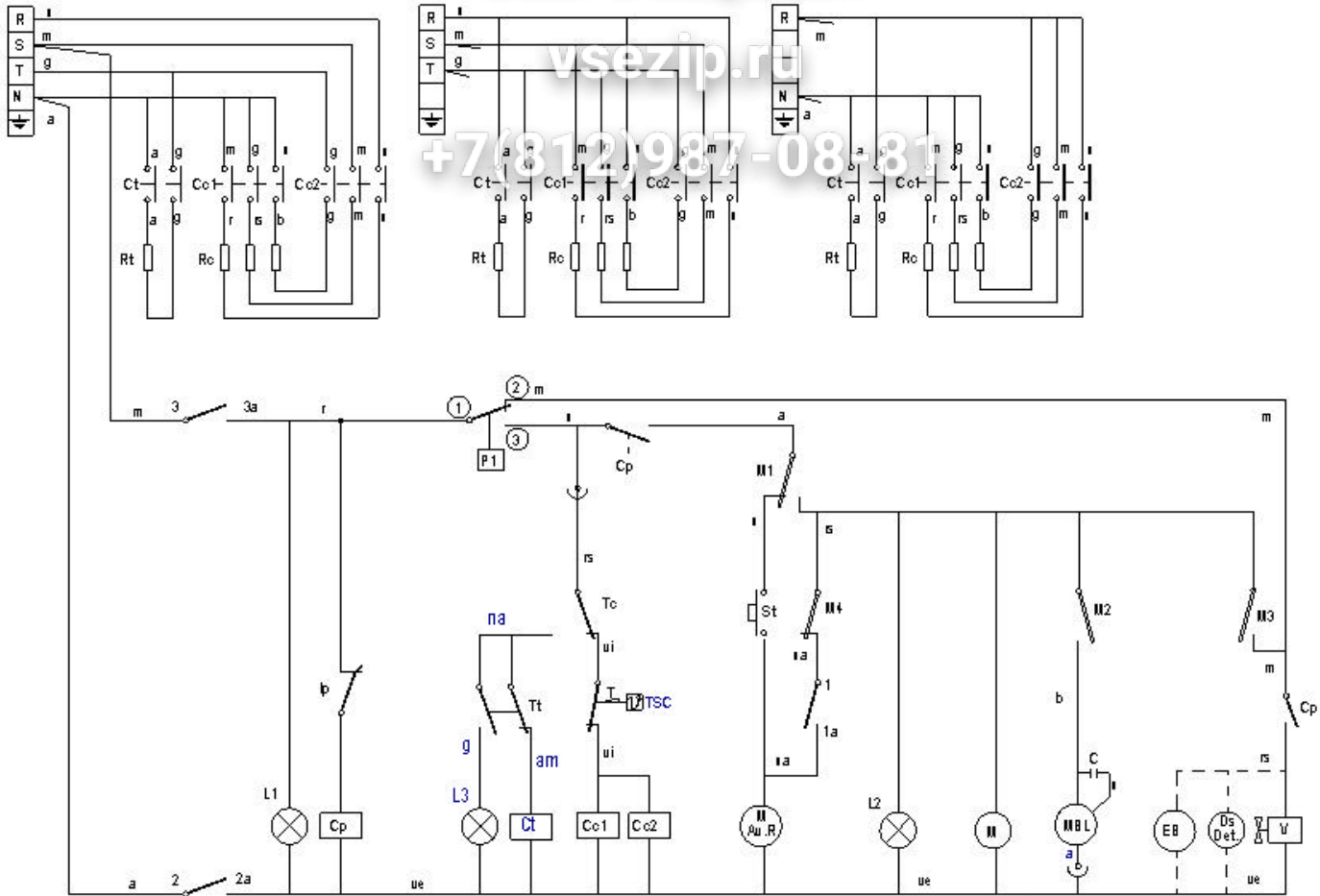

Esquema Teorico FI-64, FI-72		
Nº	Pieza	
Nº	Modificacion	
①	MLV-50 T B ERTSIOA SARTU	
Firma		Fecha
Dibujado M. Mallo		07-10-2005
Proyectado M. Mallo		07-10-2005
Comprobado <i>[Signature]</i>		07-10-2005
Escala		

FI-72W

3-фазный Общедомовый

380-415 V. 3NPh

208-220-240 V. 3 Ph

208-220-240 V. 1Ph

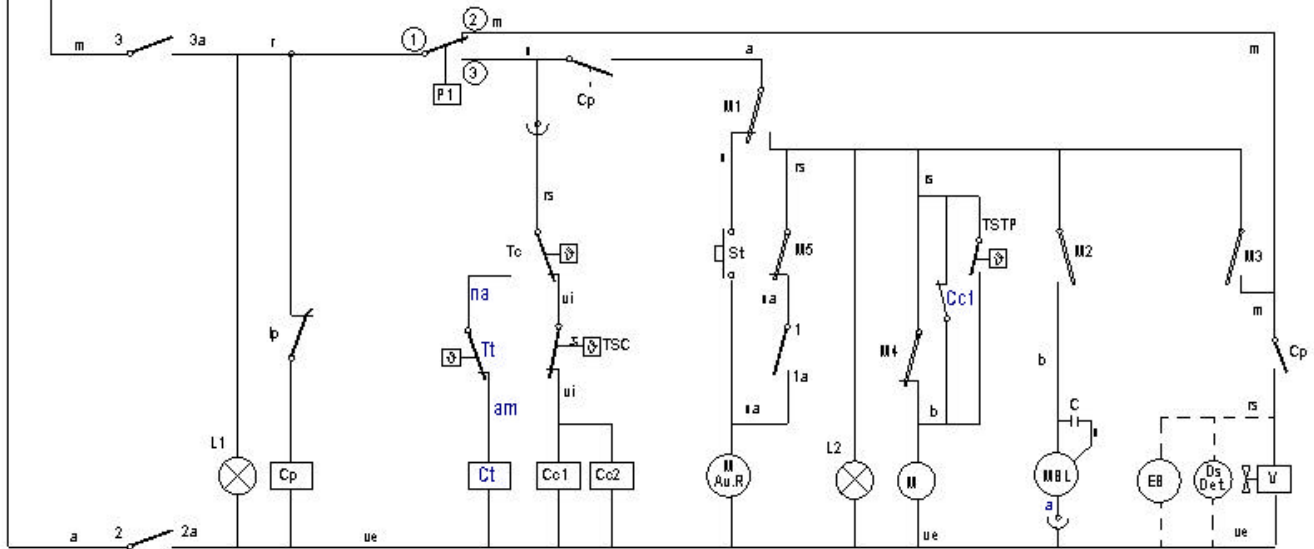
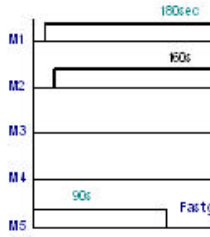
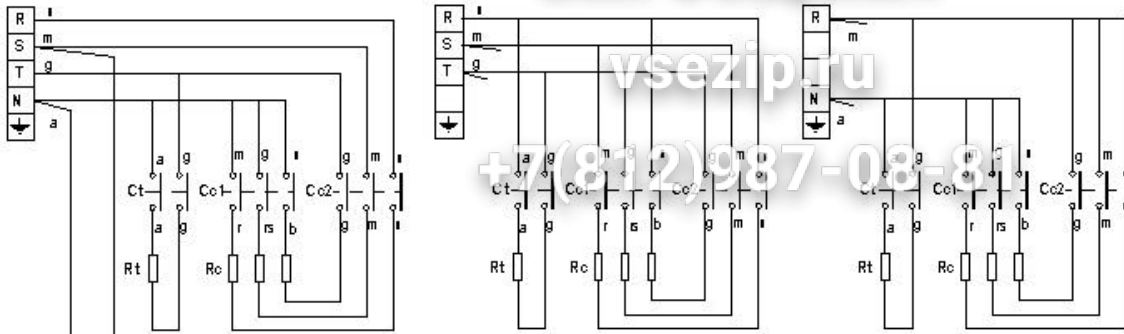

BD	Drain pump	Pompe de vidange	Bomba desagüe	M Av. R	Motor program. rapid advance
C 1/2/3	Condenser	Condensateur	Condensador	M1	Micro programmer on
CMB	Wash pump contactor	Contacteur pompe lavage	Contacto bomba lavado	M2	Micro programmer wash
Cc 1/2	Boiler heating contactor	Contacteur chauff. surchauffeur	Contacto calentamiento calderin	M3	Micro programmer on
Ct	Tank heating contactor	Contacteur chauffage cuve	Contacto calentamiento tanque	M4	Micro programmer Termo-stop
CP	Door relay	Relais porte	Rele puerta	M5	Micro programmer advance
Ds. Det.	Detergent doser	Dosseur de detergent	Dosificador detergente	P, P1, P5	Pressure switch
E.B	Electric pressure pump	Electropompe de pression	Electrobomba de presion	P2, P3, P4	Hi-limit pressure switch
IG	Main switch	Interrupteur general	Interruptor general	RC	Boiler heating element
IP	Door microswitch	Micro porte	Micro puerta	RT	Tank heater
L1	Operation light	Voyant fonctionnement	Piloto de encendido	Tt	Tank thermostat
L2	Start light	Voyant demarrage	Piloto marcha	TC	Boiler thermostat
L3	Light machine ready	Voyant machine prêt	Piloto maquina preparada	TSC	Boiler Hi-limit
MBL	Wash pump	Pompe lavage	Bomba lavado	TSTP	Termo-stop Thermostat
M	Motor programmer	Moteur du programmeur	Motor programador	V	Fill and rinse valve

Зип Ощепит

vsezip.ru

7(812)987-08-87

400 V - 3N ~

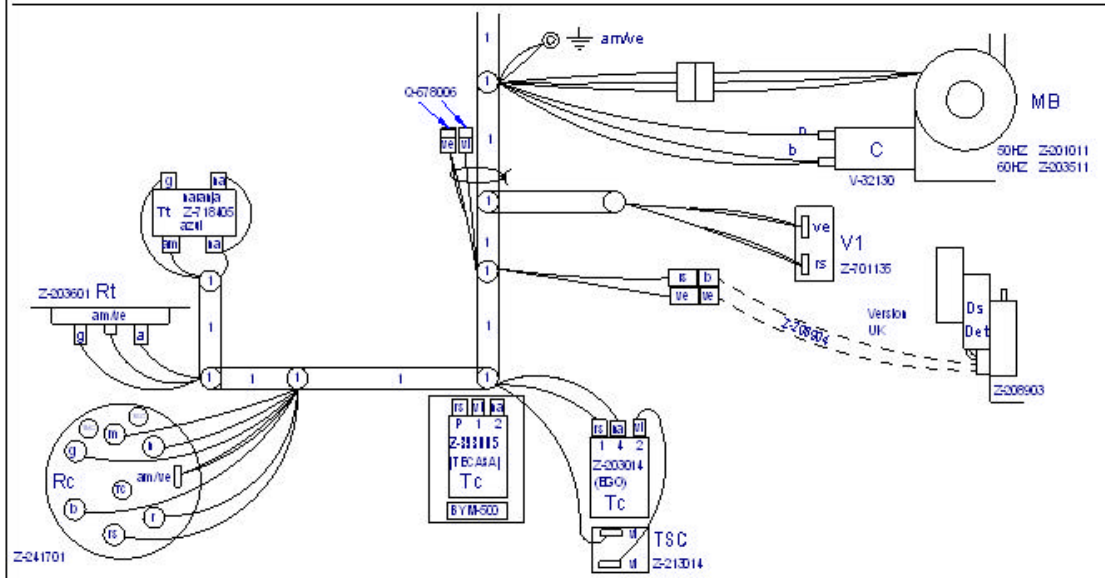
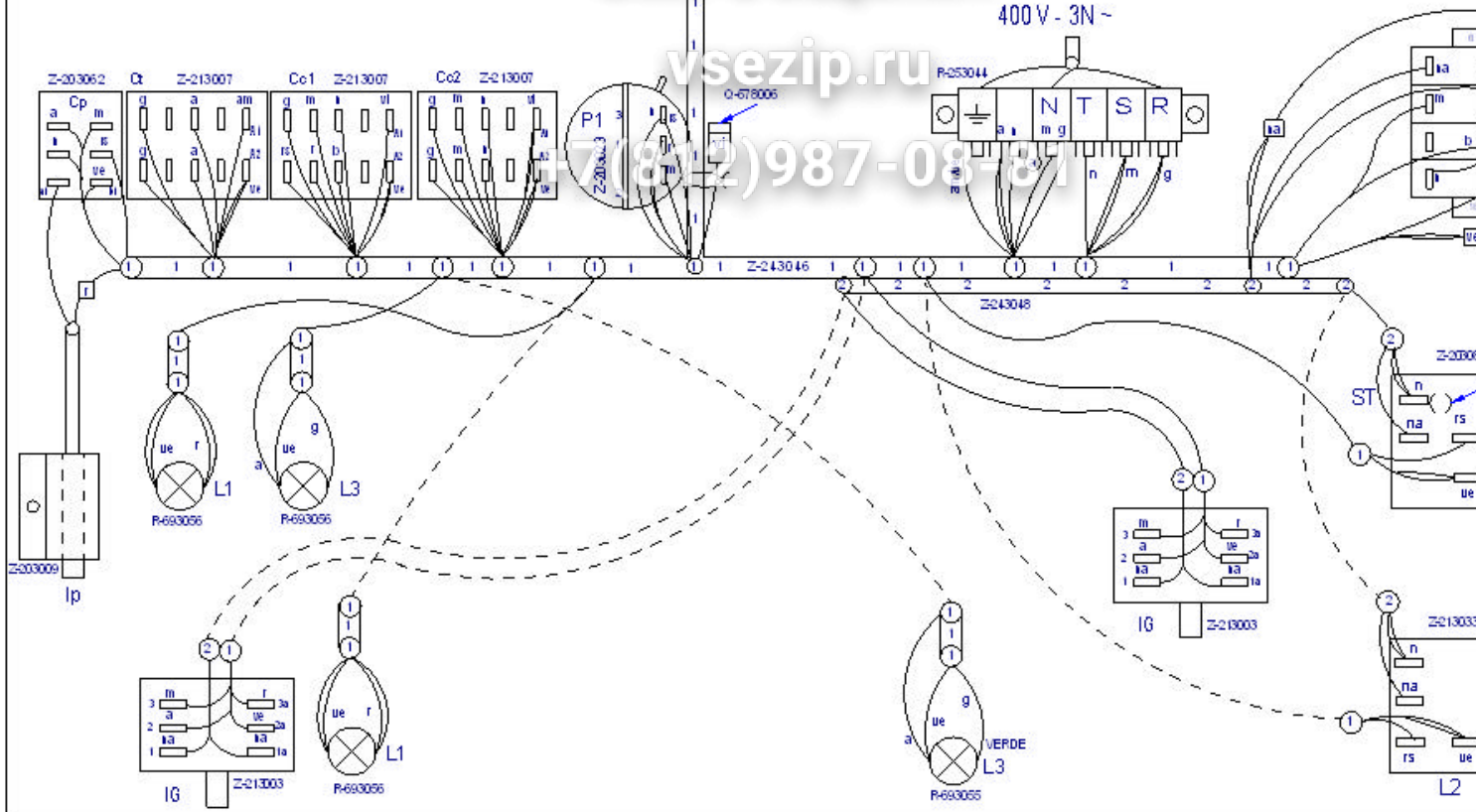

Plano montaje FI-64		
Nº Pieza		
Nº Modificación		
1	Corrección en nueva estética Fagor	
Dibujado	M. Mallo	07-10-2005
Proyectado	M. Mallo	07-10-2005
Comprobado		07-10-2005
Escala		

FI-72W

Зип-Общепит

vsezip.ru

7 (812) 987-08-87

400 V - 3N ~

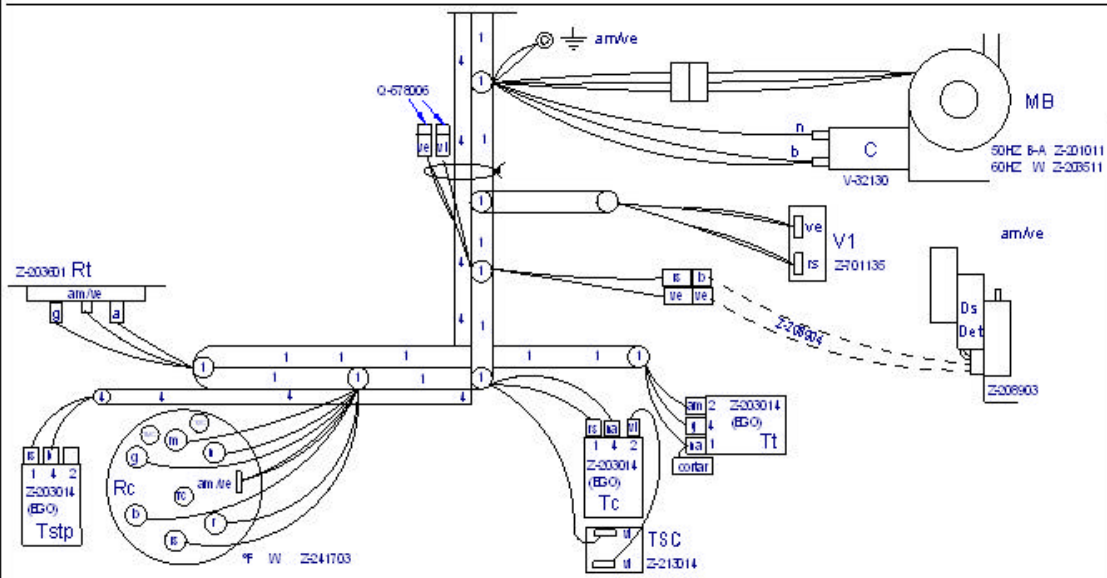
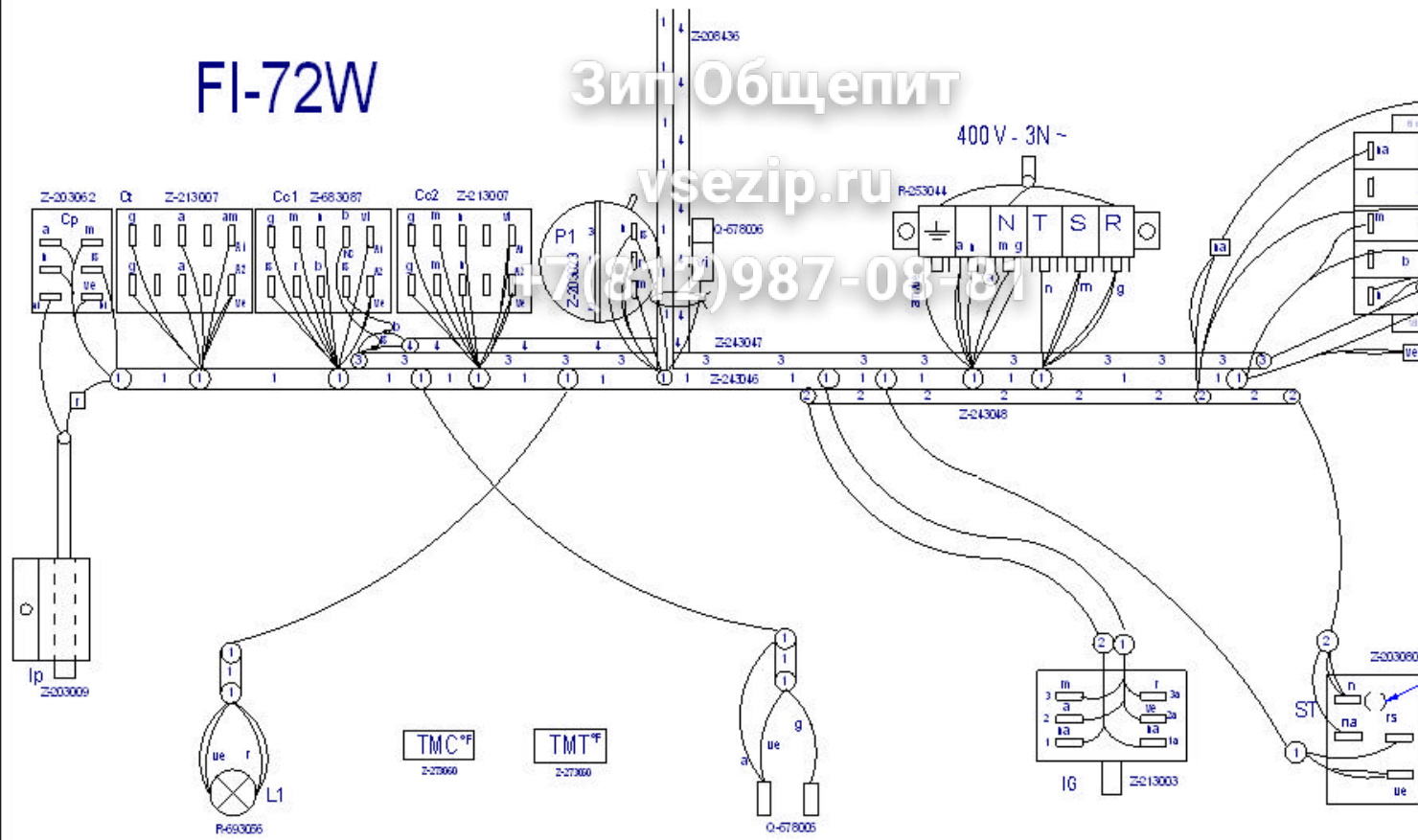

Plano montaje FI-72 W		
Nº	Pieza	
Nº	Modificación	
1	Introducir TSTP, 2 x Z-203014 y eliminar Z-21184	
2	Introducir nueva estética Fagor	
		Fecha
Dibujado	M. Mallo	07-10-2005
Proyectado	M. Mallo	07-10-2005
Comprobado		07-10-2005
Escala		
		LA
Firmas: [Signature]		