

Зип Общепит

vsezip.ru

BODY GROUP

+7(812)987-08-81

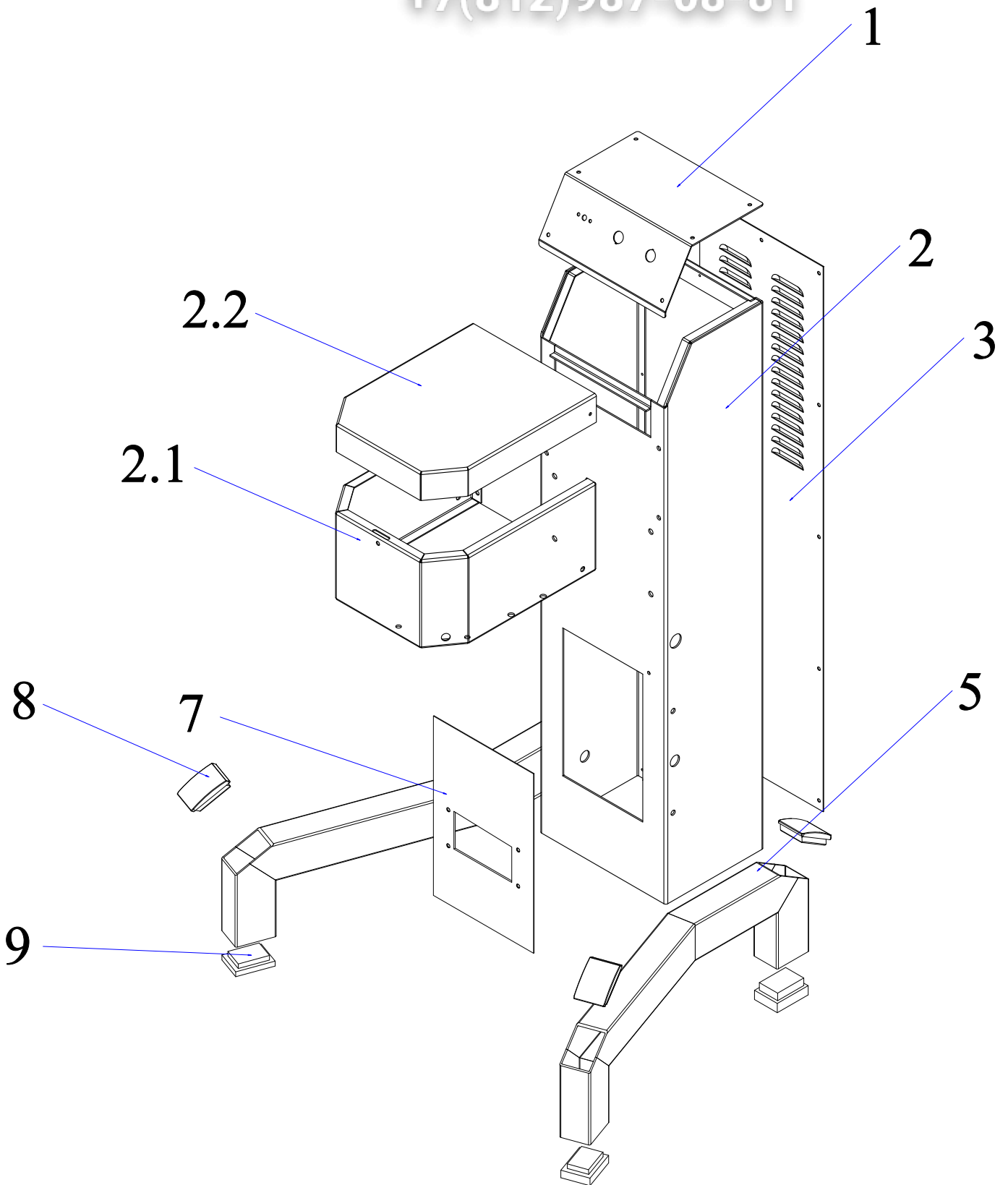

MIXING VARIATION GROUP

Зип Общепит

vsezip.ru

+7(812)987-08-81

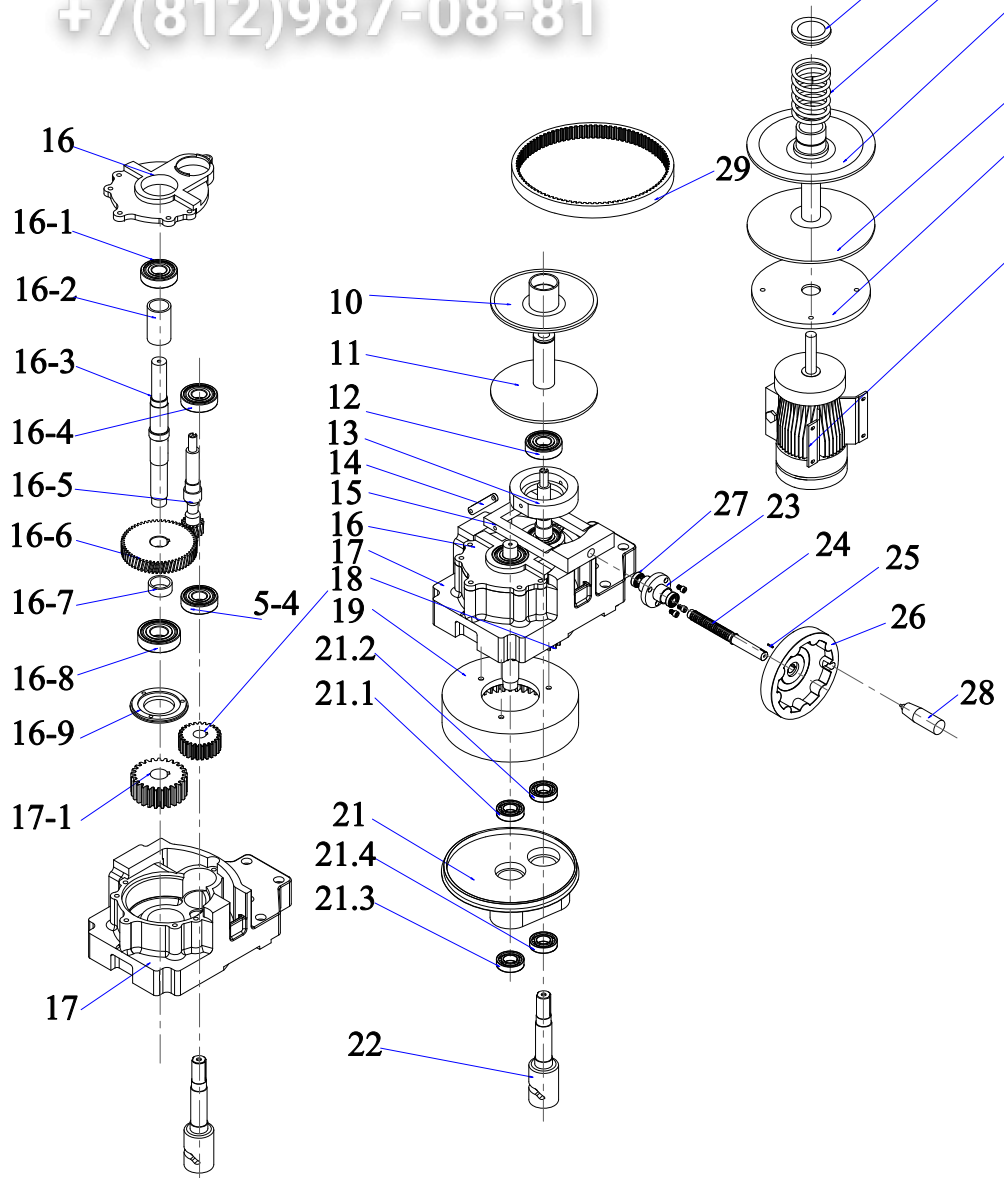

BOWL LIFT GROUP

Вип. Общепит

vsezip.ru

36

+7(812)987-08-81

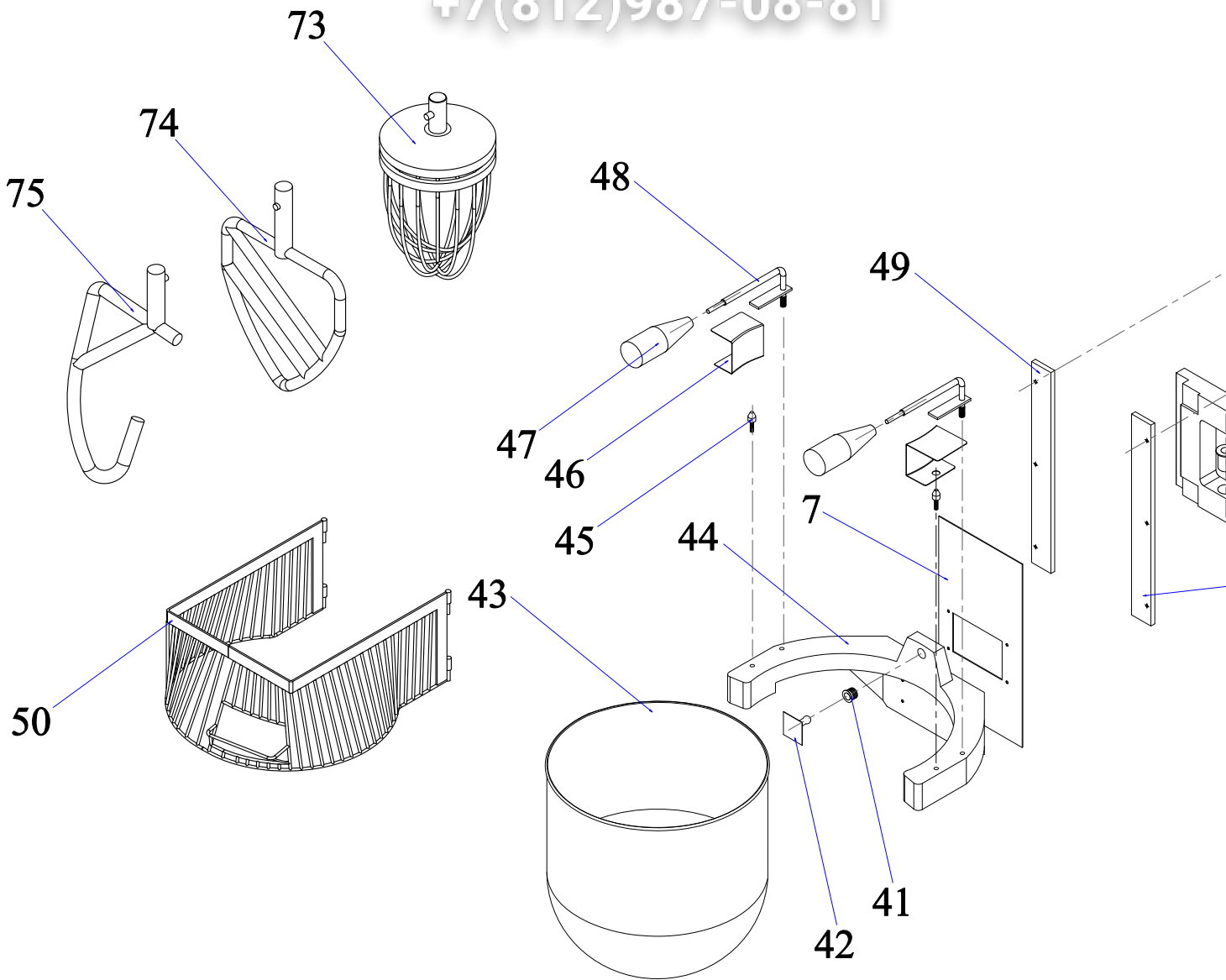

Зип Ощепит

vsezip.ru

+7(812)987-08-81

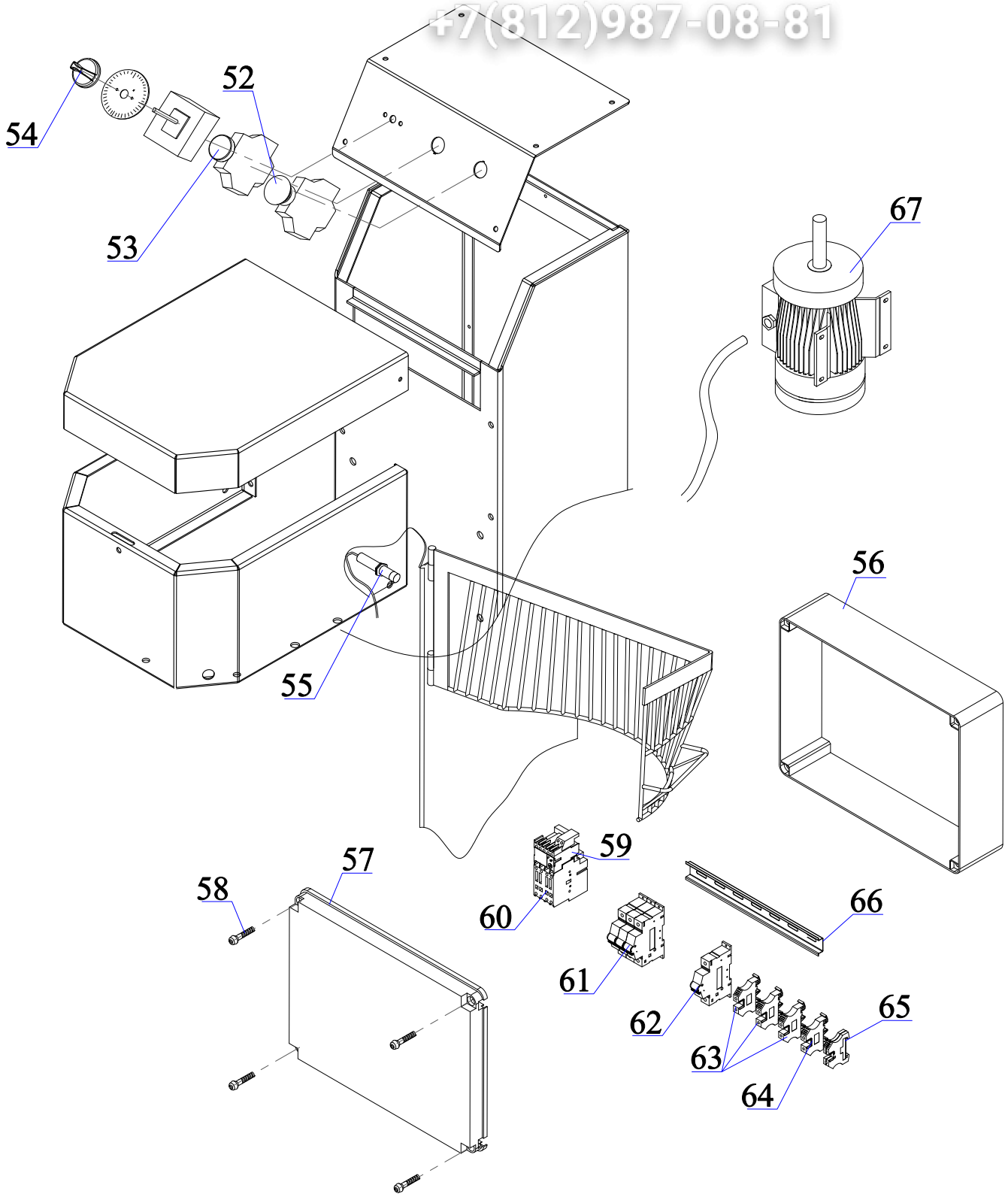

Site	POSITION NUMBER	PART CODE	Part Name
1	1	2810.20200.00	Upper Frame Sheet Metal
1	2	2810.20200.01	Main Chasis
1	3	2810.20200.02	Rear perforated sheet metal
1	2,1	2810.20200.03	Front Chasis
1	5	2810.20200.04	Leg
1	2,2	2810.20200.05	Upper Lid
1	7	2810.20200.06	Container Lever Protection
1	9	2810.20200.08	Leg Plastic Part Lower
2	10	2810.20200.09	Mid Variator Rotor Upper
2	11	2810.20200.10	Mid Variator Rotor Lower
2	12	6211.00215.00	6009 Bearing
2	13	2810.20200.11	Cycle Roller Bearing
2	14	2810.20200.12	Cycle Sledge Sheet Bar
2	15	2810.20200.13	Cycle Sledge
2	16	2810.20200.14	Gear Wheel Box Lid
2	16,1	6211.00243.00	6305 Bearing
2	16,2	2810.20200.15	Front Rotor Ring
2	16,3	2810.20200.16	Front Rotor Axle
2	16,4	6211.00243.00	6305 Bearing
2	16,5	2810.20200.17	Cycle Adjustment Axle
2	16,6	2810.20200.18	Gear Wheel Jagged
2	16,7	2810.20200.19	Gear Wheel Jagged Lower Ring
2	16,8	6211.00223.01	6207 2RS Bearing
2	16,9	2810.20200.20	Bearing Lid
2	17,1	2810.20200.21	Iron Gear
2	17	2810.20200.22	Wheel Gear Box
2	18	2810.20200.23	Polyamid Gear
2	19	2810.20200.24	Cast Gear
2	20	6211.00241.00	6303 2RS Bearing
2	21	2810.20200.25	Eccentric Gear Protection
2	21,1	6211.00208.00A	6005 Bearing
2	21,2	6211.00208.00A	6205 Bearing
2	21,3	6211.00208.00	6005 2RS Bearing
2	21,4	6211.00208.00	6005 2RS Bearing
2	22	2810.20200.26	Apparatus Fixing Axle
2	23	2810.20200.27	Cycle Pivot Bearing
2	24	2810.20200.28	Cycle Adjustment Gear Box
2	25	2810.20200.29	Cycle Adjustment Gear Cleat
2	26	6261.00028.52	
2	27	6211.00207.00	6003 Bearing
2	28	2810.40400.31	Cycle Adjustment Lever
2	29	6263.00003.11	Variator Belt 30*10*825
2	67	6252.00000.22	0,55 kW Motor
2	68	2810.20200.32	Motor Flange
2	69	2810.20200.33	Motor Variator lower rotor
2	70	2810.20200.34	Motor Variator upper rotor
2	71	2810.20200.35	Pressure Spring
2	72	2810.20200.36	Pressure Spring Washer
3	30	2810.20200.37	Container Conical Gear
3	31	6211.00390.03	51103 Bearing
3	32	2810.20200.38	Worm Gear

3	33	2810.20200.39	Container Lifting Lever
3	34	2810.20200.40	U Shapped Sledge
3	35	6261.00027.02	Bakalite Knob
3	36	2810.20200.42	Conical Gear
3	37	2810.20200.43	Outer Sledge
3	38	2810.20200.44	Yellow Gear
3	39	2810.20200.45	Inner Sledge
3	40	2810.20200.46	Sledge Sheet Bar Right
3	41	2810.20200.47	Container Nozzle Support
3	42	2810.20200.48	Container Fixing Nozzle
3	43	2810.20200.49	Container
3	44	2810.20200.50	Container Lever
3	45	2810.20200.51	Fixing Axle
3	46	2810.20200.52	Container Handle
3	47	6260.00065.00	Lock Mechanism Bakalite Knob
3	48	2810.20200.54	Lock Mechanism Lever
3	49	2810.20200.55	Container Sledge Sheet Bar
3	50	2810.20200.60	Protection Cage
3	73	2810.20200.57	Whisking Part
3	74	2810.20200.58	Mixing part
3	75	2810.20200.59	Kneading Part
4	52	6232.00003.06	Stop Button
4	53	6232.00003.02	Start Button
4	54	6259.00002.05	Timer
4	55	6232.00006.00	Switch emas babl
4	59	6233.00016.01	Thermic Relay
4	60	6230.00014.12	Moeller 10 Contactor
4	61	6236.00400.12	N otomat BKN-C1P2 LG
4	62	6236.00400.01	N otomat BKN-C3P6 LG