

Зип Общепит

vsezip.ru

+7(812)987-08-81

DISHWASHER

ELECTROMECHANICAL SWITCHES
LOWER WASHING
LOWER AND UPPER WASHING

TYPE: 6U

Accessories
BREAK TANK
BOOSTER PUMP
DVGW
COLD RINSE
WATER SOFTNER
DETERGENT DISPENSER
DRAIN PUMP

Spare Parts Manual

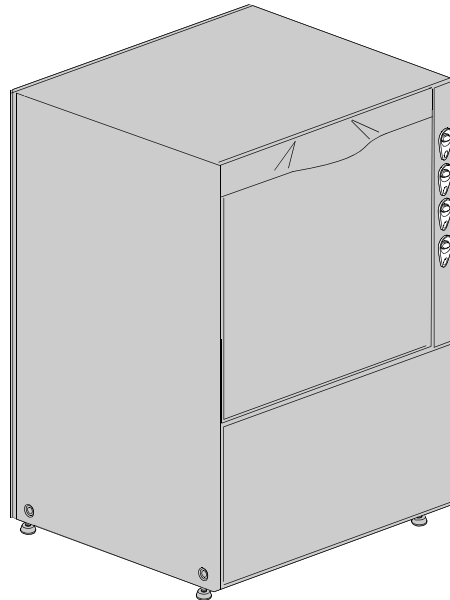

INFORMAZIONI GENERALI

Questo catalogo serve per richiedere con esattezza le parti di ricambio

Nelle ordinazioni indicare:

1) il numero dei codici dei particolari seguito dalla descrizione e la quantità desiderata;

2) Il codice alfa-numerico presente nella seconda colonna della tabella ;

I disegni delle parti di ricambio sono solo indicativi e non rappresentano il pezzo in oggetto.

I dati contenuti in questo catalogo sono indicativi e possono essere soggetti a modifiche senza impegno di preavviso.

ALLGEMEINE INFORMATIONEN

Dieser Ersatzteilkatalog dient zur genauen Angabe der Teile bei Ersatzteilbestellungen.

Bei Ersatzbestellung ist folgendes anzugeben:

1) Die Bestellnummer der Ersatzteile mit der entsprechenden Beschreibung genaue Menge;

2) Der alpha-numerischer Code auf der zweiten Reihe in dein Sculd;

Die Zeichnungen der Ersatzteile sind nur als Hinweise gedacht und stellen nicht das betroffene Teil dar.

Bei den im Katalog angeführten Daten handelt es sich um Anhaltsdaten, die jederzeit, ohne Vorankündigung, geändert werden können.

GENERAL INFORMATION

The present spare parts order exactly the right spare parts

When ordering specify:

1) the part's code number followed by its description and quantity needed;

2) The alpha-numeric code is in the second column in the chart;

Spare parts drawings are general and do not represent the part.

The contents of this catalogue are general and can undergo changes without prior notice.

INFORMACIONES GENERALES

El presente catálogo sirve para pedir con exactitud las partes de repuesto

En los pedidos se debe indicar:

1) el número de código de la parte y a continuación la descripción cantidad deseada;

2) El código alfanumerico presente en la segnada columna de la tabla;

Los diseños de las partes de recambio son solo indicativos y no representan la pieza en cuestión.

Los datos contenidos en el presente catálogo son indicativos y pueden modificarse sin aviso previo.

INFORMATIONS GENERALES

Ce catalogue permet de commander correctement les pièces détachées

Les commandes doivent être passées en indiquant:

1) le numero de code des pièces détachées suivi de leur description quantité désirée;

2) le code alphanumérique dans la deuxième colonne du tableau;

Les plans des pièces détachées sont fournis seulement à titre indicatif et ne représentent pas la pièce concernée.

Les données de ce catalogue sont citées seulement à titre indicatif et peuvent être l'objet de modifications sans avis préalable.

ESEMPIO

EXAMPLE

EXEMPLE

BEISPIEL

Rif.	Codici
MODULE:Particolari	
10505	540903
10510	540908
10515	15065/A
10520	540086
10525	540028

Note

Tutte le informazioni riportate si intendono aggiornate alla data di stampa. Il Produttore si riserva il diritto di apportare qualsiasi modifica richiesta dallo sviluppo evolutivo dei suddetti prodotti.

Per la sicurezza, la garanzia, l'affidabilità ed il valore della lavastoviglie usa solo ricambi originali. **Per alcuni codici, sono richieste quantità minime d'ordine.**

Attenzione

Questo libretto è parte integrante della lavastoviglie e, in caso di passaggio di proprietà, deve essere consegnato al nuovo acquirente.

Note

The information contained herein is valid at the time of going to print. The Company reserves the right to make any changes required by the future development of the above-mentioned products.

For your safety, as well as to preserve the warranty reliability and worth of your dishwashers, use original spare parts only. **For some codes a minimum quantity for order is required.**

Warning

This manual forms an integral part of the dishwashers and - if a transfer of title occurs - must always be handed over to the new owner.

Remarque

Toutes les informations contenues dans ce manuel s'entendent mises à jour à la date d'impression. En raison du développement constant de ses produits, usine se réserve le droit d'apporter à tout instant les modifications qu'elle jugera utiles.

Pour la sécurité, la garantie, la fiabilité et la valeur de votre lavevaisselles n'utilisez que des pièces de rechange d'origine. **Pour quelque référence on demande un minimum de pièces par commande**

Attention

Ce manuel doit être considéré comme partie intégrante de la lavevaisselles, en cas de transfert de propriété, doit toujours être remis au nouveau propriétaire.

Hinweis

Die Der Hersteller behält sich das Recht vor, jegliche, durch eine Weiterentwicklung der genannten Produkte bedingte Änderungen vornehmen zu können.

Verwenden Sie für Ihre Sicherheit, die Garantie, die Zuverlässigkeit und den Wert Ihrer machine originale Ersatzteile. **Für bestimmte Code nummer werden mindesten bestellungen verlangt.**

Achtung

Diese Betriebsanleitung ist Bestandteile des machine und muss bei seinem Weiterverkauf dem neuen Besitzer ausgehändigt werden.

vsezip.ru
+7(812)987-08-81

Code 999XXYYYY **CL/Part**

Model DESCRIPTION

S/N 04012345 **Type**

400VAC3N 50HZ 8A
3500W 500W

16A

200-500

TECHICAL SPECIFICATION

MADE IN ITALY

Pressione Dinamica alimentazione idrica
Pression dynamique arrivée d'eau
Dynamic pressure water supply
Dynamischer Druck assereinlauf

Pressione dinamica vapore saturo
Pression dynamique vapeur satueèè
Dymanischer Druck gesattigter Dampf
Pression Dinamica Vapor Saturado

Temperatura massima acqua in ingresso **60°C**
Temperature max eau a l'entre
Maximale Temperatur Wasseranschliù
Maximum Water temperature in-feeding

Model

S/N



FAMIGLIA PRODOTTO
FAMILY PRODUCT
FAMILLE DU PRODUIT
FAMILIA PRODUCTO
FAMILIE DES PRODUKTES

CODICE MODELLO
CODE MODEL
CODE ARTICLE
CODIGO MODELO
KODE VON MODELL

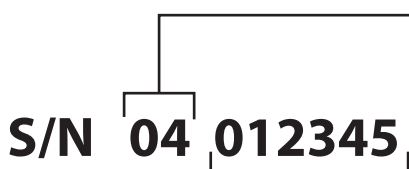

ANNO
YEAR
ANNÉE
AN"O
JAHR

NUMERO DI SERIE
SERIAL NUMBER
NUMÉRO DI SÉRIE
NUMERO DI SERIE
SERIENNUMMER

Spare parts

Зип Общепит

vsezip.ru

+7(812)987-08-81

vsezip.ru

+7(812)987-08-81

1. Spare parts

General body parts.....	7
Lockup system	9
Control panel and switches.....	11
Electric control components.....	13
Solenoid valve group	15
Solenoid valve group	17
Solenoid valve group	19
Break Tank	21
Break Tank	23
Booster pump.....	25
DVGW	27
Water softner group.....	29
Rinse aid dispenser group.....	31
Rinse aid dispenser group.....	33
Boiler group	35
3 ways connection	37

4 ways connection	39
Wash pump	41
Wash pump	43
Dosing detergent group.....	45
Drain pump group.....	47
Pressure switch group with air trap ...	49
Turret group with rotating arms	51
Turret group with rotating arms	55

1.1 Voltage codes

Volt	Voltage code
A	3/N/PE~380-400V 50-60Hz
D	3/PE~200-210V 50-60Hz
F	2/PE~220-240V 50-60Hz
G	3/N/PE~415V 50-60Hz
H	3/PE~220-230V 50-60Hz
K	3/PE~380-400V 50-60Hz
L	3/PE~415V 50-60Hz
M	3/PE~440V 60Hz
P	1/N/PE~220-230V 50-60Hz
R	2/PE~220-240V 50-60Hz
U	1/N/PE~240V 50-60Hz
V	3/PE~240V 50-60Hz
W	1/N/PE~100-110V 50-60Hz

1.2 Product codes

Product code	Full name
Model codes	
em	ELECTROMECHANICAL SWITCHES
lw	LOWER WASHING
uw	LOWER AND UPPER WASHING
Type codes	
6U	6U
Accessory codes	
bt	BREAK TANK
bp	BOOSTER PUMP
dvgw	DVGW
cr	COLD RINSE
ws	WATER SOFTNER
dd	DETERGENT DISPENSER
dp	DRAIN PUMP

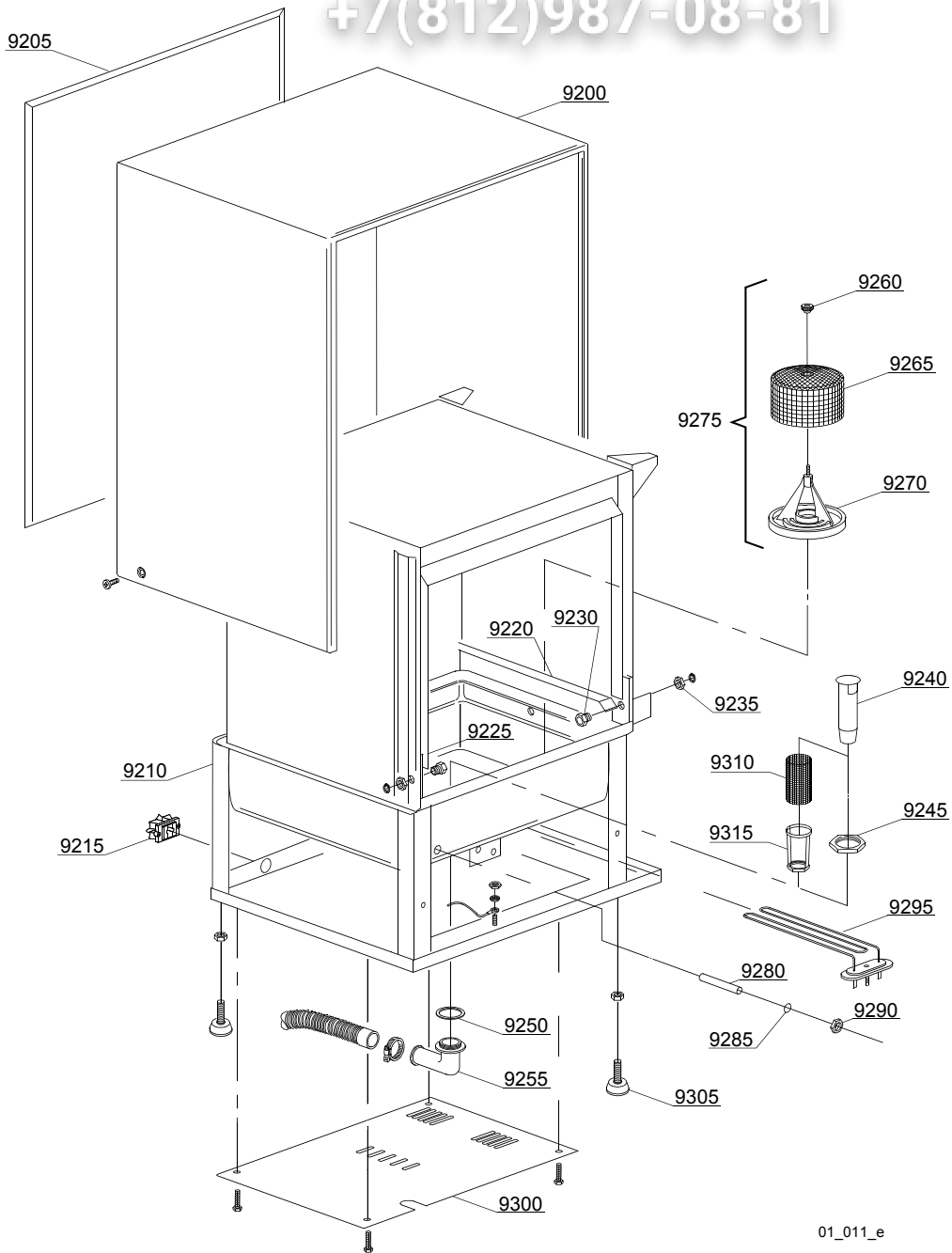

01_011_e

ID	P-code	SN from	SN to	Mod.	Acces.	Volt	Description
Module:General body parts							
9200	16007		-				Cover
9205	16010		-	lw			Back panel
9205	16011		-	uw			Back panel
9210	16982		-				Body
9210	16981		-		ws		Body
9215	15065/A		-				Cable-fastener with screw
9220	16914		-				Right internal slide
9225	16914/A		-				Left internal slide
9230	11835		-				Brass bush with nut
9235	11815		-				Ø8 stainless steel snap ring (minimum 5 pieces)
9240	16052		-				Overflow pipe
9245	11701/A		-				Stainless steel nut
9250	13305		-				44x32x3 O-ring (minimum 5 pieces)
9255	10701		-				Drain elbow
9260	11713		-				Nut for filter fixing
9265	16050		-				Stainless steel net filter
9270	16051		-				Filter bottom Ø30 hole
9270	16051/A		-				Filter bottom Ø50 hole
9275	16906		-				Ø30 suction filter
9275	16906/A		-				Ø50 suction filter
9280	12510		-				Thermostat feeler-holder
9285	13309		-				10x14x1,5 O-ring (minimum 20 pieces)
9290	11714		-				M10x1 stainless steel nut for thermostat feeler-holder
9295	16035/A		-				1,85/2,02KW 230/240V heating element
9300	16086		-				End piece protection
9305	10786		-				M10x25 Ø40 black foot (minimum 4 pieces)
9310	440751		-		dp		Drain pump stainless steel filter
9315	11701/B		-		dp		Stainless steel nut

em=ELECTROMECHANICAL SWITCHES, lw=LOWER WASHING, uw=LOWER AND UPPER WASHING

6U=6U

bt=BREAK TANK, bp=BOOSTER PUMP, dvgw=DVGW, cr=COLD RINSE, ws=WATER SOFTNER, dd=DETERGENT DISPENSER, dp=DRAIN PUMP

A=3/N/PE~380-400V 50-60Hz, D=3/PE~200-210V 50-60Hz, F=2/PE~220-240V 50-60Hz, G=3/N/PE~415V 50-60Hz, H=3/PE~220-230V 50-60Hz, K=3/PE~380-400V 50-60Hz, L=3/PE~415V 50-60Hz, M=3/PE~440V 60Hz, P=1/N/PE~220-230V 50-60Hz, R=2/PE~220-240V 50-60Hz, U=1/N/PE~240V 50-60Hz, V=3/PE~240V 50-60Hz, W=1/N/PE~100-110V 50-60Hz

vsezip.ru

+7(812)987-08-81

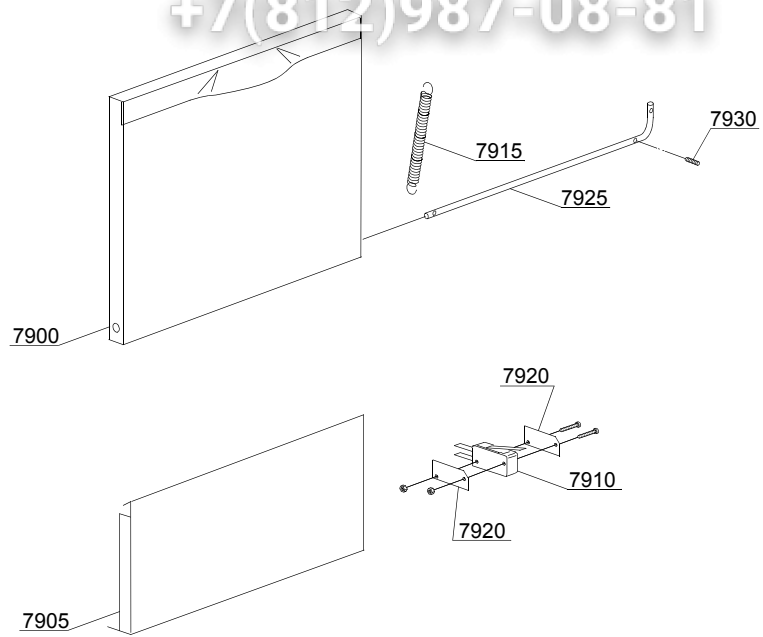

02_107_e

vsezip.ru

ID	P-code	SN from	SN to	Mod	Acces.	Volt	Description
Module: Lockup system							
7900	16972		-				Door with steel handle
7905	16016		-				Lower door
7910	10704		-				Door microswitch
7915	10700/B		-				Spring
7920	10770		-				Insulation for door microswitch (minimum 3 pieces)
7925	16046		-				Door rod
7930	11170		-				M5x25 grub-screw (minimum 2 pieces)

em=ELECTROMECHANICAL SWITCHES, lw=LOWER WASHING, uw=LOWER AND UPPER WASHING

6U=6U

bt=BREAK TANK, bp=BOOSTER PUMP, dvgw=DVGW, cr=COLD RINSE, ws=WATER SOFTNER, dd=DETERGENT DISPENSER, dp=DRAIN PUMP

A=3/N/PE~380-400V 50-60Hz, D=3/PE~200-210V 50-60Hz, F=2/PE~220-240V 50-60Hz, G=3/N/PE~415V 50-60Hz, H=3/PE~220-230V 50-60Hz, K=3/PE~380-400V 50-60Hz, L=3/PE~415V 50-60Hz, M=3/PE~440V 60Hz, P=1/N/PE~220-230V 50-60Hz, R=2/PE~220-240V 50-60Hz, U=1/N/PE~240V 50-60Hz, V=3/PE~240V 50-60Hz, W=1/N/PE~100-110V 50-60Hz

vsezip.ru

+7(812)987-08-81

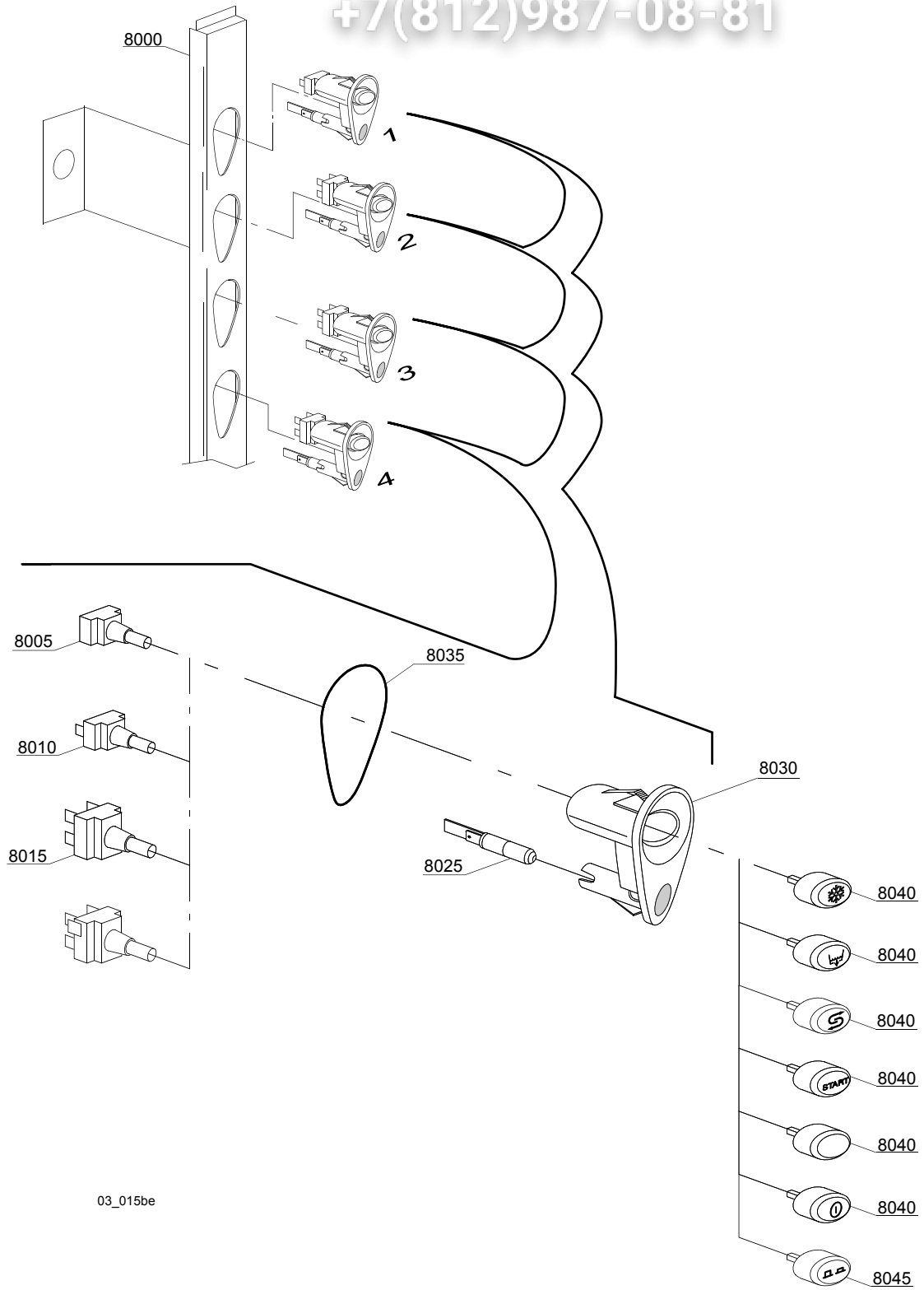

ID	P-code	SN from	SN to	Mod	Acces.	Volt	Description
Module:Control panel and switches							
8000	16939		-	em			Control panel
8005	15844		-	em			Push button support
8010	15813		-	em			16A unipolar switch
8015	15800		-	em			16A bipolar switch
8015	15812		-	em			16A switch
8020	15811		-	em			16A bipolar switch
8020	15811/A		-	em			16A bipolar switch
8025	15826		-	em			Pilot light
8030	89300		-	em			Push button support
8035	89332		-	em			OR O-ring (minimum 10 pieces)
8040	89344		-	em	cr		Hot/cold push button
8040	89343		-	em	dp		Drain pump push button
8040	89341		-	em			Start push button
8040	89348		-	em			Blind push button
8040	89340		-	em			ON-OFF push button
8040	89345		-	em	ws		Regeneration push button

em=ELECTROMECHANICAL SWITCHES, lw=LOWER WASHING, uw=LOWER AND UPPER WASHING

6U=6U

bt=BREAK TANK, bp=BOOSTER PUMP, dvgw=DVGW, cr=COLD RINSE, ws=WATER SOFTNER, dd=DETERGENT DISPENSER, dp=DRAIN PUMP

A=3/N/PE~380-400V 50-60Hz, D=3/PE~200-210V 50-60Hz, F=2/PE~220-240V 50-60Hz, G=3/N/PE~415V 50-60Hz, H=3/PE~220-230V 50-60Hz, K=3/PE~380-400V 50-60Hz, L=3/PE~415V 50-60Hz, M=3/PE~440V 60Hz, P=1/N/PE~220-230V 50-60Hz, R=2/PE~220-240V 50-60Hz, U=1/N/PE~240V 50-60Hz, V=3/PE~240V 50-60Hz, W=1/N/PE~100-110V 50-60Hz

vsezip.ru

+7(812)987-08-81

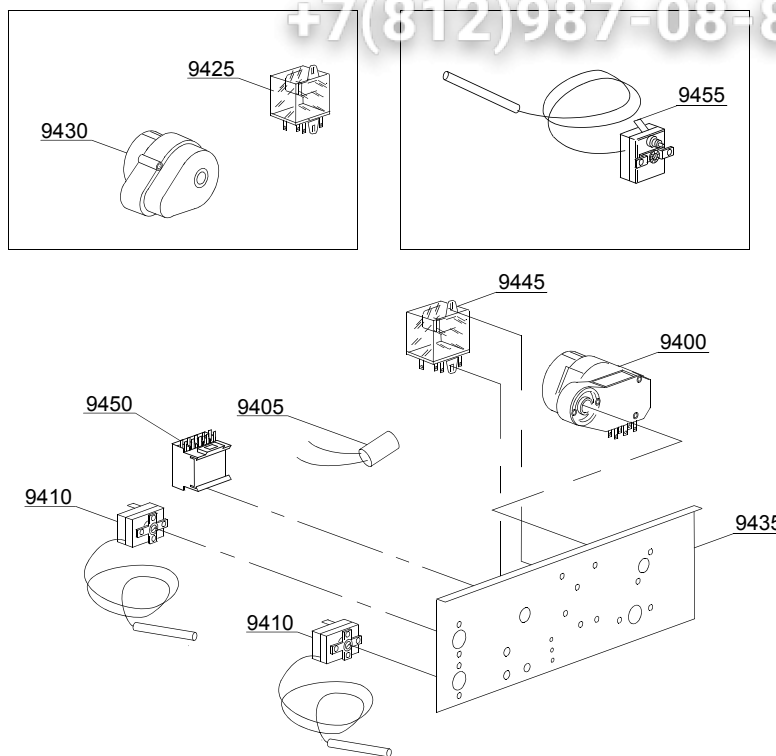

04_010_e

vsezip.ru

ID	P-code	SN from	SN to	Mod.	Acces.	Volt	Description
Module: Electric control components							
9400	10708/L		-			A	120" timer - 230Vac 50Hz
9400	10708/B		-				120" timer - 220Vac 60Hz
9400	10708/T		-				Timer 120" with thermostop - 230Vac 50Hz
9405	15146		-				Low noise filter
9410	10707/1		-				0-90°C thermostat
9425	16047		-		ws		Tripolar relay 16A - 230Vac 50/60 Hz
9430	16064/A		-		ws		Regeneration timer
9435	16019/A		-				Electric components panel
9445	15620		-				16A bipolar relay in deviation
9450	15086		-				Contactora 230V 50/60Hz 4C (for boiler heat.el-em.>3Kw)
9450	15086/B		-				Contactora 240V 50Hz (for boiler heat.elem.>3Kw)

em=ELECTROMECHANICAL SWITCHES, lw=LOWER WASHING, uw=LOWER AND UPPER WASHING

6U=6U

bt=BREAK TANK, bp=BOOSTER PUMP, dvgw=DVGW, cr=COLD RINSE, ws=WATER SOFTNER, dd=DETERGENT DISPENSER, dp=DRAIN PUMP

A=3/N/PE~380-400V 50-60Hz, D=3/PE~200-210V 50-60Hz, F=2/PE~220-240V 50-60Hz, G=3/N/PE~415V 50-60Hz, H=3/PE~220-230V 50-60Hz, K=3/PE~380-400V 50-60Hz, L=3/PE~415V 50-60Hz, M=3/PE~440V 60Hz, P=1/N/PE~220-230V 50-60Hz, R=2/PE~220-240V 50-60Hz, U=1/N/PE~240V 50-60Hz, V=3/PE~240V 50-60Hz, W=1/N/PE~100-110V 50-60Hz

vsezip.ru

+7(812)987-08-81

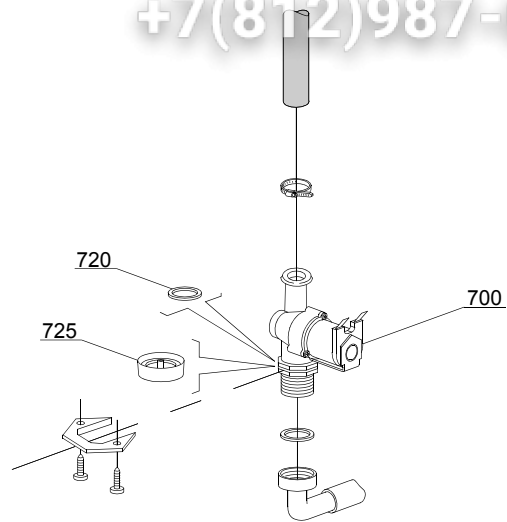

05_002_e

vsezip.ru

ID	P-code	SN from	SN to	Mod	Acces.	Volt	Description
Module:Solenoid valve group							
700	10703		-	em			Single solenoid valve - 220Vac
720	N.C.		-	em			Pression reducing valve

em=ELECTROMECHANICAL SWITCHES, lw=LOWER WASHING, uw=LOWER AND UPPER WASHING

6U=6U

bt=BREAK TANK, bp=BOOSTER PUMP, dvgw=DVGW, cr=COLD RINSE, ws=WATER SOFTNER, dd=DETERGENT DISPENSER, dp=DRAIN PUMP

A=3/N/PE~380-400V 50-60Hz, D=3/PE~200-210V 50-60Hz, F=2/PE~220-240V 50-60Hz, G=3/N/PE~415V 50-60Hz, H=3/PE~220-230V 50-60Hz, K=3/PE~380-400V 50-60Hz, L=3/PE~415V 50-60Hz, M=3/PE~440V 60Hz, P=1/N/PE~220-230V 50-60Hz, R=2/PE~220-240V 50-60Hz, U=1/N/PE~240V 50-60Hz, V=3/PE~240V 50-60Hz, W=1/N/PE~100-110V 50-60Hz

vsezip.ru

+7(812)987-08-81

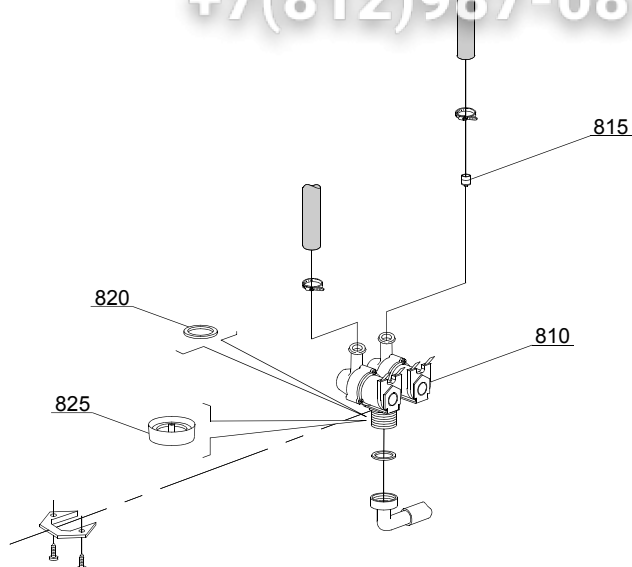

05_003_e

vsezip.ru

ID	P-code	SN from	SN to	Mod.	Acces.	Volt	Description
Module:Solenoid valve group							
810	15098		-	em	cr,ws		Double solenoid valve - Ø10 - 220Vac
820	N.C.		-	em	cr,ws		Pression reducing valve

em=ELECTROMECHANICAL SWITCHES, lw=LOWER WASHING, uw=LOWER AND UPPER WASHING

6U=6U

bt=BREAK TANK, bp=BOOSTER PUMP, dvgw=DVGW, cr=COLD RINSE, ws=WATER SOFTNER, dd=DETERGENT DISPENSER, dp=DRAIN PUMP

A=3/N/PE~380-400V 50-60Hz, D=3/PE~200-210V 50-60Hz, F=2/PE~220-240V 50-60Hz, G=3/N/PE~415V 50-60Hz, H=3/PE~220-230V 50-60Hz, K=3/PE~380-400V 50-60Hz, L=3/PE~415V 50-60Hz, M=3/PE~440V 60Hz, P=1/N/PE~220-230V 50-60Hz, R=2/PE~220-240V 50-60Hz, U=1/N/PE~240V 50-60Hz, V=3/PE~240V 50-60Hz, W=1/N/PE~100-110V 50-60Hz

vsezip.ru

+7(812)987-08-81

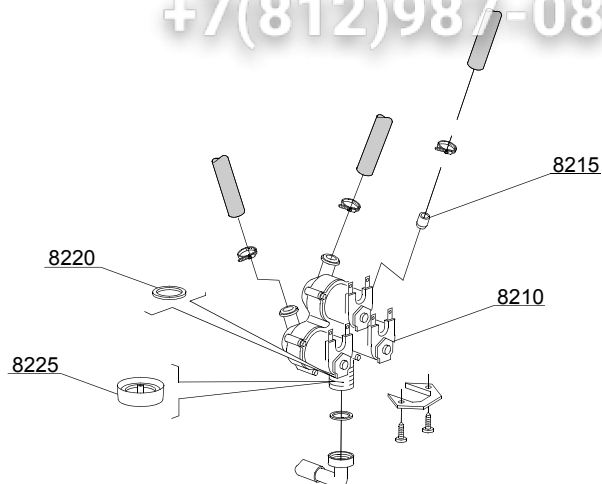

05_004_e

vsezip.ru

ID	P-code	SN from	SN to	Mod.	Acces.	Volt	Description
Module:Solenoid valve group							
8210	15099		-		cr,ws		Triple solenoid valve
8215	15115		-		cr,ws		Green pression solenoid valve (minimum 2 pieces)
8220	N.C.		-		cr,ws		Pression reducing valve

em=ELECTROMECHANICAL SWITCHES, lw=LOWER WASHING, uw=LOWER AND UPPER WASHING

6U=6U

bt=BREAK TANK, bp=BOOSTER PUMP, dvgw=DVGW, cr=COLD RINSE, ws=WATER SOFTNER, dd=DETERGENT DISPENSER, dp=DRAIN PUMP

A=3/N/PE~380-400V 50-60Hz, D=3/PE~200-210V 50-60Hz, F=2/PE~220-240V 50-60Hz, G=3/N/PE~415V 50-60Hz, H=3/PE~220-230V 50-60Hz, K=3/PE~380-400V 50-60Hz, L=3/PE~415V 50-60Hz, M=3/PE~440V 60Hz, P=1/N/PE~220-230V 50-60Hz, R=2/PE~220-240V 50-60Hz, U=1/N/PE~240V 50-60Hz, V=3/PE~240V 50-60Hz, W=1/N/PE~100-110V 50-60Hz

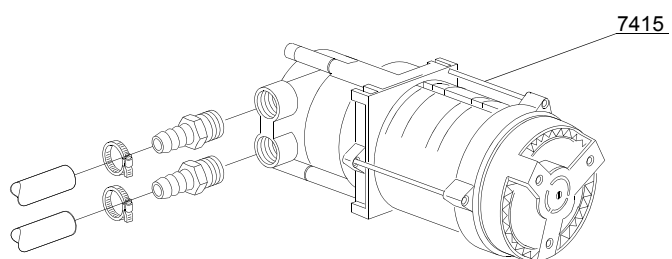
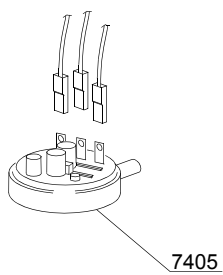
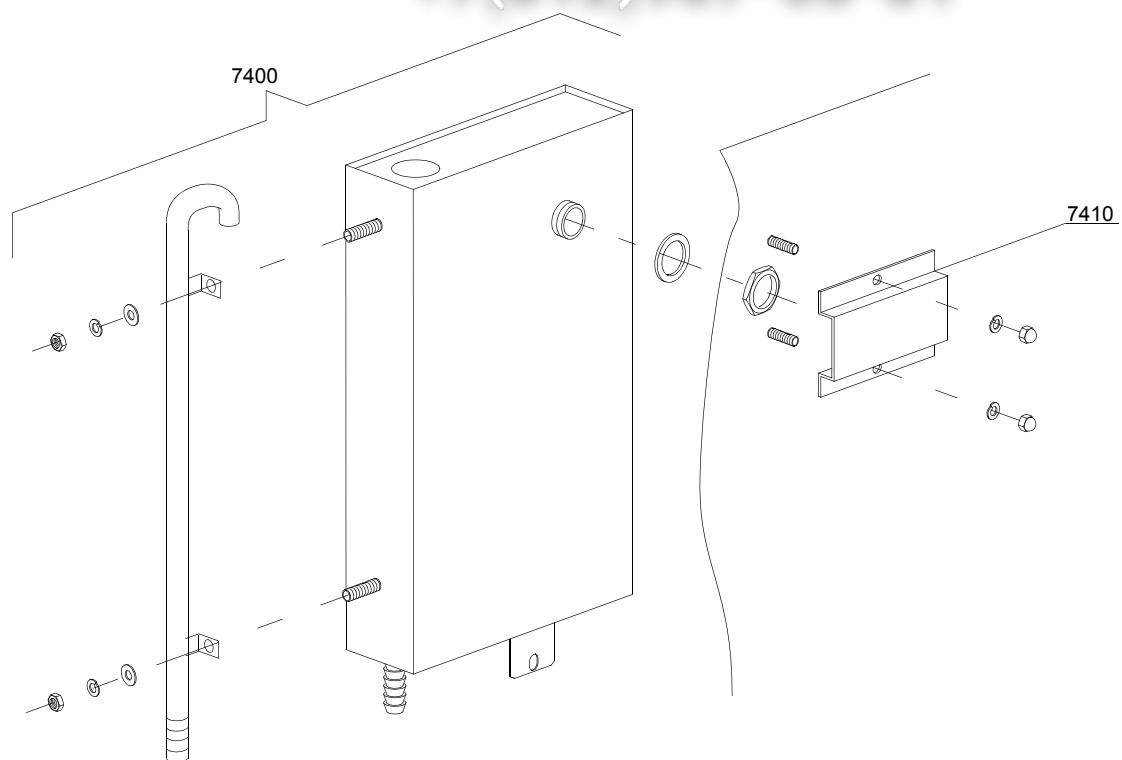

vsezip.ru

ID	P-code	SN from	SN to	Mod.	Acces.	Volt	Description
Module:Break Tank							
7400	15735		-		bt		Break tank assembly
7405	10706/A		-		bt		47-27 pressure switch
7410	15738		-		bt		Overflow cover
7415	15100/D		-		bt		Booster pump 220/240V

em=ELECTROMECHANICAL SWITCHES, lw=LOWER WASHING, uw=LOWER AND UPPER WASHING

6U=6U

bt=BREAK TANK, bp=BOOSTER PUMP, dvgw=DVGW, cr=COLD RINSE, ws=WATER SOFTNER, dd=DETERGENT DISPENSER, dp=DRAIN PUMP

A=3/N/PE~380-400V 50-60Hz, D=3/PE~200-210V 50-60Hz, F=2/PE~220-240V 50-60Hz, G=3/N/PE~415V 50-60Hz, H=3/PE~220-230V 50-60Hz, K=3/PE~380-400V 50-60Hz, L=3/PE~415V 50-60Hz, M=3/PE~440V 60Hz, P=1/N/PE~220-230V 50-60Hz, R=2/PE~220-240V 50-60Hz, U=1/N/PE~240V 50-60Hz, V=3/PE~240V 50-60Hz, W=1/N/PE~100-110V 50-60Hz

vsezip.ru

+7(812)987-08-81

06_004_e

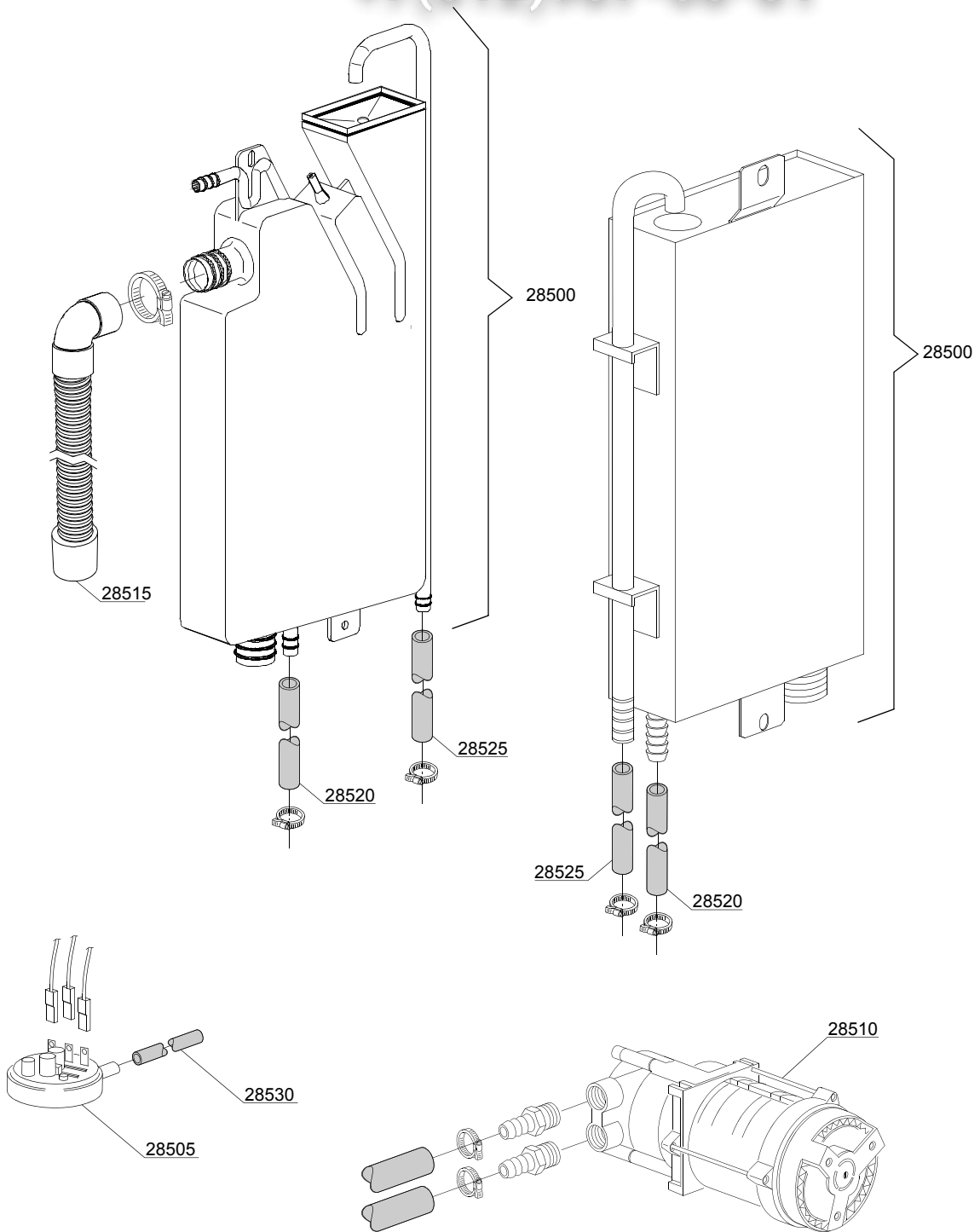

vsezip.ru

ID	P-code	SN from	SN to	Mod.	Acces.	Volt	Description
Module:Break Tank							
28500	15735		-		bt		Break tank assembly
28505	10706/A		-		bt		47-27 pressure switch
28510	15100/D		-		bt		Booster pump 220/240V
28515	15721		-		bt		BT long pipe L=1070
28515	15722		-		bt		BT middle pipe L=920
28515	15723		-		bt		BT small pipe L=920
28520	2907350		-		bt		12x20 EPDM rubber hose
28525	2907352		-		bt		PVC WRAS rubber hose
28530	14508		-		bt		4,5x9 EPDM rubber hose (minimum 2 mt)

em=ELECTROMECHANICAL SWITCHES, lw=LOWER WASHING, uw=LOWER AND UPPER WASHING

6U=6U

bt=BREAK TANK, bp=BOOSTER PUMP, dvgw=DVGW, cr=COLD RINSE, ws=WATER SOFTNER, dd=DETERGENT DISPENSER, dp=DRAIN PUMP

A=3/N/PE~380-400V 50-60Hz, D=3/PE~200-210V 50-60Hz, F=2/PE~220-240V 50-60Hz, G=3/N/PE~415V 50-60Hz, H=3/PE~220-230V 50-60Hz, K=3/PE~380-400V 50-60Hz, L=3/PE~415V 50-60Hz, M=3/PE~440V 60Hz, P=1/N/PE~220-230V 50-60Hz, R=2/PE~220-240V 50-60Hz, U=1/N/PE~240V 50-60Hz, V=3/PE~240V 50-60Hz, W=1/N/PE~100-110V 50-60Hz

vsezip.ru

+7(812)987-08-81

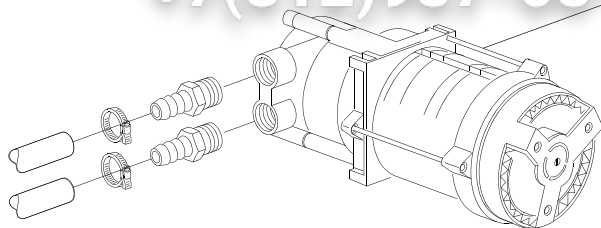

07_003_e

vsezip.ru

ID	P-code	SN from	SN to	Mod.	Acces.	Volt	Description
Module: Booster pump							
7500	15100/D		-	em	bp		Booster pump 220/240V

em=ELECTROMECHANICAL SWITCHES, lw=LOWER WASHING, uw=LOWER AND UPPER WASHING

6U=6U

bt=BREAK TANK, bp=BOOSTER PUMP, dvgw=DVGW, cr=COLD RINSE, ws=WATER SOFTNER, dd=DETERGENT DISPENSER, dp=DRAIN PUMP

A=3/N/PE~380-400V 50-60Hz, D=3/PE~200-210V 50-60Hz, F=2/PE~220-240V 50-60Hz, G=3/N/PE~415V 50-60Hz, H=3/PE~220-230V 50-60Hz, K=3/PE~380-400V 50-60Hz, L=3/PE~415V 50-60Hz, M=3/PE~440V 60Hz, P=1/N/PE~220-230V 50-60Hz, R=2/PE~220-240V 50-60Hz, U=1/N/PE~240V 50-60Hz, V=3/PE~240V 50-60Hz, W=1/N/PE~100-110V 50-60Hz

vsezip.ru

+7(812)987-08-81

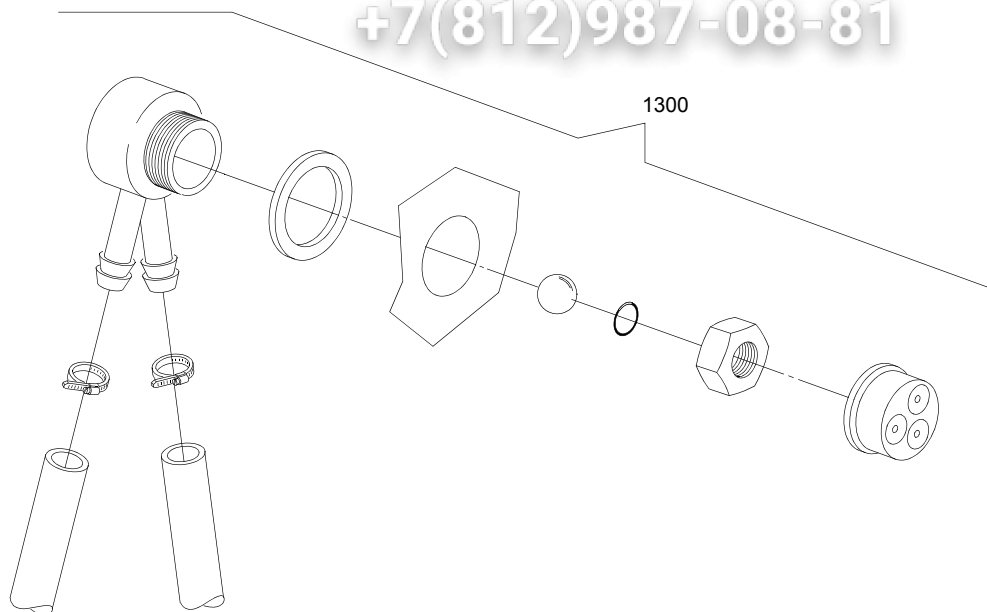

08_005_e

vsezip.ru

ID	P-code	SN from	SN to	Mod	Acces.	Volt	Description
Module:DVGW							
1300	999900006		-		dvgw		DVGW assembly

em=ELECTROMECHANICAL SWITCHES, lw=LOWER WASHING, uw=LOWER AND UPPER WASHING
6U=6U

bt=BREAK TANK, bp=BOOSTER PUMP, dvgw=DVGW, cr=COLD RINSE, ws=WATER SOFTNER, dd=DETERGENT DISPENSER, dp=DRAIN PUMP

A=3/N/PE~380-400V 50-60Hz, D=3/PE~200-210V 50-60Hz, F=2/PE~220-240V 50-60Hz, G=3/N/PE~415V 50-60Hz, H=3/PE~220-230V 50-60Hz, K=3/PE~380-400V 50-60Hz, L=3/PE~415V 50-60Hz, M=3/PE~440V 60Hz, P=1/N/PE~220-230V 50-60Hz, R=2/PE~220-240V 50-60Hz, U=1/N/PE~240V 50-60Hz, V=3/PE~240V 50-60Hz, W=1/N/PE~100-110V 50-60Hz

09_001_e

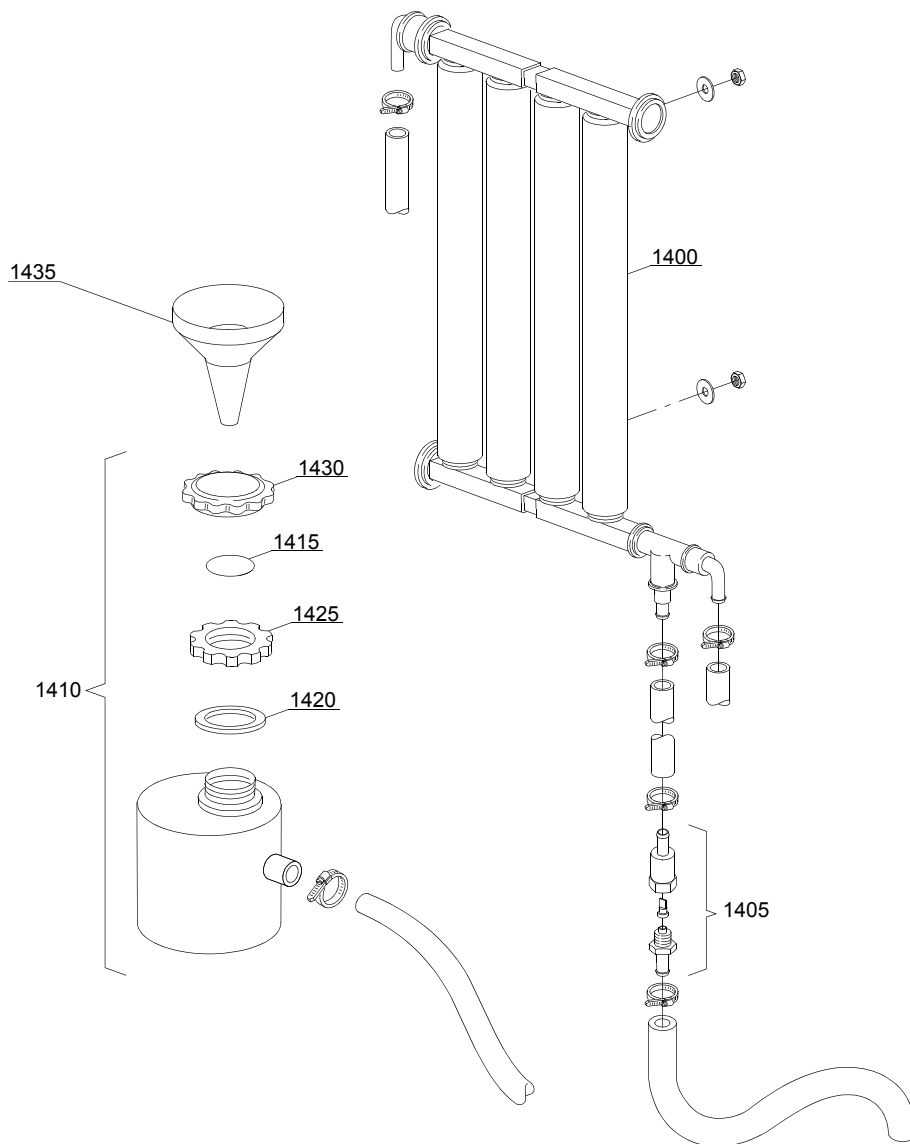

vsezip.ru

ID	P-code	SN from	SN to	Mod.	Acces.	Volt	Description
Module: Water softner group							
1400	16066		-		ws		4 elements water softner
1405	16070		-		ws		Nonreturn valve
1410	16065		-		ws		Salt container
1415	16067/A		-		ws		OR O-ring
1420	16067/B		-		ws		O-ring
1425	16067/C		-		ws		Ring nut
1430	16067/D		-		ws		Plug
1435	16082		-		ws		Funnel

em=ELECTROMECHANICAL SWITCHES, lw=LOWER WASHING, uw=LOWER AND UPPER WASHING

6U=6U

bt=BREAK TANK, bp=BOOSTER PUMP, dvgw=DVGW, cr=COLD RINSE, ws=WATER SOFTNER, dd=DETERGENT DISPENSER, dp=DRAIN PUMP

A=3/N/PE~380-400V 50-60Hz, D=3/PE~200-210V 50-60Hz, F=2/PE~220-240V 50-60Hz, G=3/N/PE~415V 50-60Hz, H=3/PE~220-230V 50-60Hz, K=3/PE~380-400V 50-60Hz, L=3/PE~415V 50-60Hz, M=3/PE~440V 60Hz, P=1/N/PE~220-230V 50-60Hz, R=2/PE~220-240V 50-60Hz, U=1/N/PE~240V 50-60Hz, V=3/PE~240V 50-60Hz, W=1/N/PE~100-110V 50-60Hz

vsezip.ru

+7(812)987-08-81

10_002_e

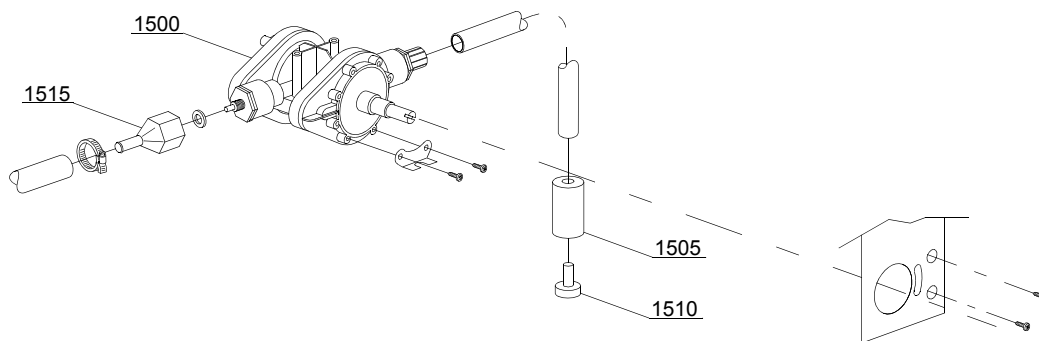

vsezip.ru

ID	P-code	SN from	SN to	Mod.	Acces.	Volt	Description
Module: Rinse aid dispenser group							
1500	10798		-				Rinse aid dispenser
1505	12525		-				Counter-weight
1510	15058		-				Small filter (minimum 3 pieces)
1515	10798/B		-				Brass pipe fitting

em=ELECTROMECHANICAL SWITCHES, lw=LOWER WASHING, uw=LOWER AND UPPER WASHING

6U=6U

bt=BREAK TANK, bp=BOOSTER PUMP, dvgw=DVGW, cr=COLD RINSE, ws=WATER SOFTNER, dd=DETERGENT DISPENSER, dp=DRAIN PUMP

A=3/N/PE~380-400V 50-60Hz, D=3/PE~200-210V 50-60Hz, F=2/PE~220-240V 50-60Hz, G=3/N/PE~415V 50-60Hz, H=3/PE~220-230V 50-60Hz, K=3/PE~380-400V 50-60Hz, L=3/PE~415V 50-60Hz, M=3/PE~440V 60Hz, P=1/N/PE~220-230V 50-60Hz, R=2/PE~220-240V 50-60Hz, U=1/N/PE~240V 50-60Hz, V=3/PE~240V 50-60Hz, W=1/N/PE~100-110V 50-60Hz

vsezip.ru

+7(812)987-08-81

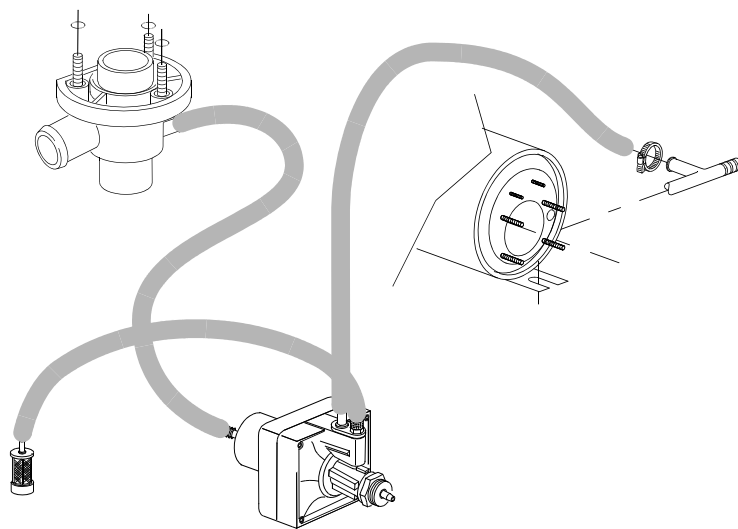
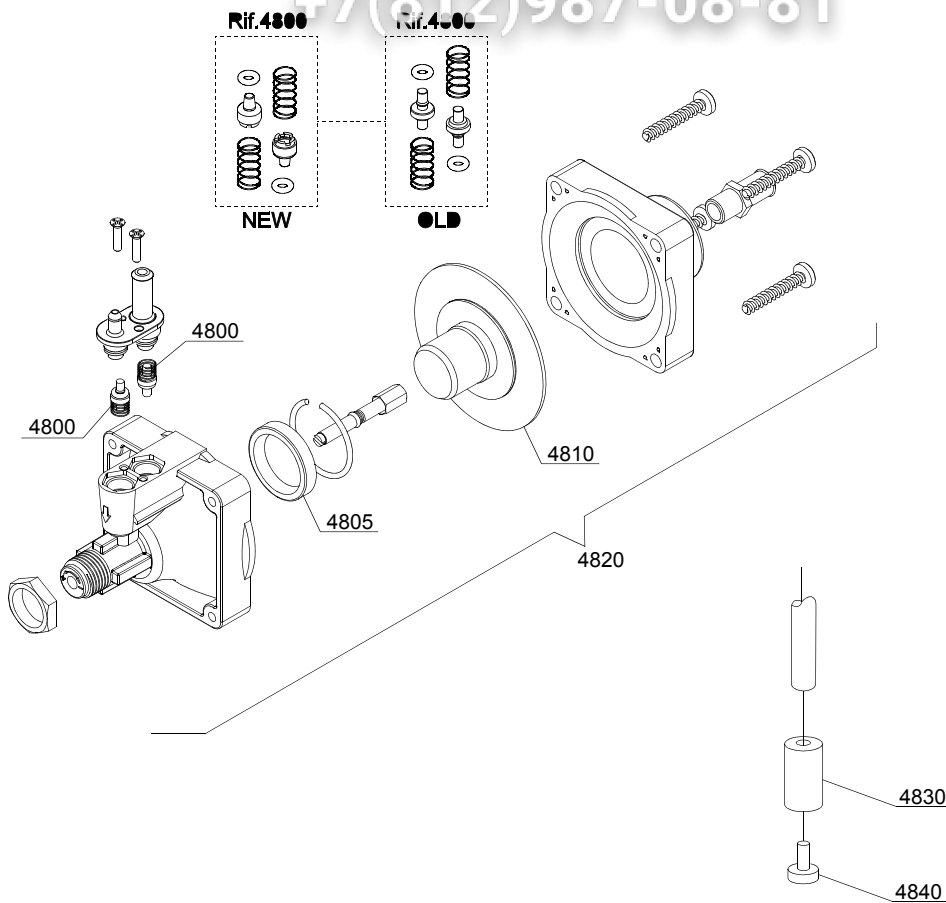

10_004_e

vsezip.ru

ID	P-code	SN from	SN to	Mod	Acces.	Volt	Description
Module: Rinse aid dispenser group							
4800	10805		-				Tecnopro non return valve
4805	10806		-				Ø22 O-ring
4810	10807		-				Membrane
4820	10799		-				Rinse aid dispenser
4830	12525		-				Counter-weight
4840	15058		-				Small filter (minimum 3 pieces)

em=ELECTROMECHANICAL SWITCHES, lw=LOWER WASHING, uw=LOWER AND UPPER WASHING

6U=6U

bt=BREAK TANK, bp=BOOSTER PUMP, dvgw=DVGW, cr=COLD RINSE, ws=WATER SOFTNER, dd=DETERGENT DISPENSER, dp=DRAIN PUMP

A=3/N/PE~380-400V 50-60Hz, D=3/PE~200-210V 50-60Hz, F=2/PE~220-240V 50-60Hz, G=3/N/PE~415V 50-60Hz, H=3/PE~220-230V 50-60Hz, K=3/PE~380-400V 50-60Hz, L=3/PE~415V 50-60Hz, M=3/PE~440V 60Hz, P=1/N/PE~220-230V 50-60Hz, R=2/PE~220-240V 50-60Hz, U=1/N/PE~240V 50-60Hz, V=3/PE~240V 50-60Hz, W=1/N/PE~100-110V 50-60Hz

vsezip.ru

+7(812)987-08-81

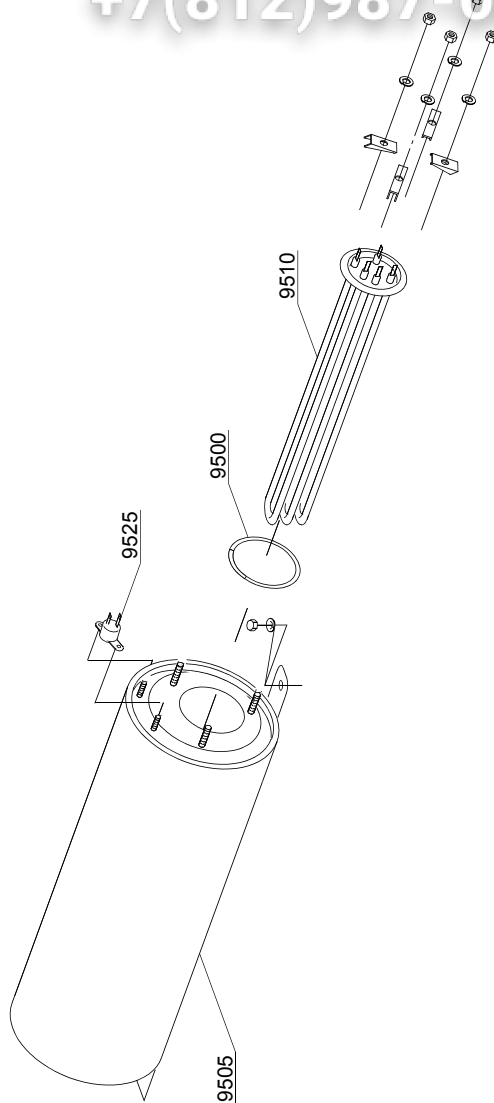

ID	P-code	SN from	SN to	Mod.	Acces.	Volt	Description
Module:Boiler group							
9500	13005		-				OR 151 NBR O-ring (minimum 5 pieces)
9505	16904		-				Boiler
9510	16036/A		-				2,18/2,37KW 230/240V heating element
9510	16036		-				1,84/2KW 230/240V heating element
9510	15046		-				3/3,27KW 230/240V 3 heating element
9525	15550		-				Safety thermostat

em=ELECTROMECHANICAL SWITCHES, lw=LOWER WASHING, uw=LOWER AND UPPER WASHING

6U=6U

bt=BREAK TANK, bp=BOOSTER PUMP, dvgw=DVGW, cr=COLD RINSE, ws=WATER SOFTNER, dd=DETERGENT DISPENSER, dp=DRAIN PUMP

A=3/N/PE~380-400V 50-60Hz, D=3/PE~200-210V 50-60Hz, F=2/PE~220-240V 50-60Hz, G=3/N/PE~415V 50-60Hz, H=3/PE~220-230V 50-60Hz, K=3/PE~380-400V 50-60Hz, L=3/PE~415V 50-60Hz, M=3/PE~440V 60Hz, P=1/N/PE~220-230V 50-60Hz, R=2/PE~220-240V 50-60Hz, U=1/N/PE~240V 50-60Hz, V=3/PE~240V 50-60Hz, W=1/N/PE~100-110V 50-60Hz

vsezip.ru

+7(812)987-08-81

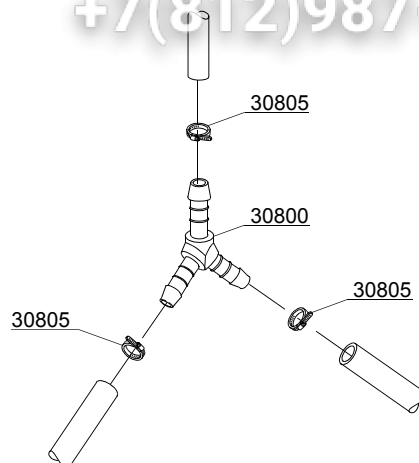

12_003ae

vsezip.ru

ID	P-code	SN from	SN to	Mod.	Acces.	Volt	Description
Module:3 ways connection							
30800	540090		-	em			Ø10 mm plastic 3 ways connection
30805	11807		-	em			12/22 clamp (minimum 3 pieces)

em=ELECTROMECHANICAL SWITCHES, lw=LOWER WASHING, uw=LOWER AND UPPER WASHING

6U=6U

bt=BREAK TANK, bp=BOOSTER PUMP, dvgw=DVGW, cr=COLD RINSE, ws=WATER SOFTNER, dd=DETERGENT DISPENSER, dp=DRAIN PUMP

A=3/N/PE~380-400V 50-60Hz, D=3/PE~200-210V 50-60Hz, F=2/PE~220-240V 50-60Hz, G=3/N/PE~415V 50-60Hz, H=3/PE~220-230V 50-60Hz, K=3/PE~380-400V 50-60Hz, L=3/PE~415V 50-60Hz, M=3/PE~440V 60Hz, P=1/N/PE~220-230V 50-60Hz, R=2/PE~220-240V 50-60Hz, U=1/N/PE~240V 50-60Hz, V=3/PE~240V 50-60Hz, W=1/N/PE~100-110V 50-60Hz

vsezip.ru

+7(812)987-08-81

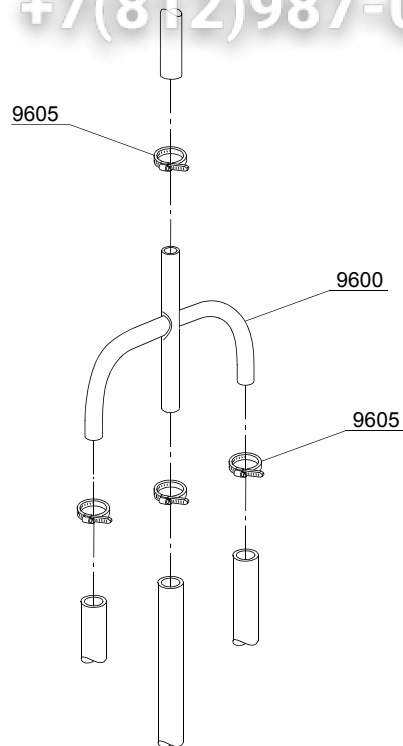

12_004_e

vsezip.ru

ID	P-code	SN from	SN to	Mod	Acces	Volt	Description
Module:4 ways connection							
9600	15151		-	em	cr		Ø10 mm 4 ways connection
9605	11807		-	em	cr		12/22 clamp (minimum 3 pieces)

em=ELECTROMECHANICAL SWITCHES, lw=LOWER WASHING, uw=LOWER AND UPPER WASHING

6U=6U

bt=BREAK TANK, bp=BOOSTER PUMP, dvgw=DVGW, cr=COLD RINSE, ws=WATER SOFTNER, dd=DETERGENT DISPENSER, dp=DRAIN PUMP

A=3/N/PE~380-400V 50-60Hz, D=3/PE~200-210V 50-60Hz, F=2/PE~220-240V 50-60Hz, G=3/N/PE~415V 50-60Hz, H=3/PE~220-230V 50-60Hz, K=3/PE~380-400V 50-60Hz, L=3/PE~415V 50-60Hz, M=3/PE~440V 60Hz, P=1/N/PE~220-230V 50-60Hz, R=2/PE~220-240V 50-60Hz, U=1/N/PE~240V 50-60Hz, V=3/PE~240V 50-60Hz, W=1/N/PE~100-110V 50-60Hz

vsezip.ru

+7(812)987-08-81

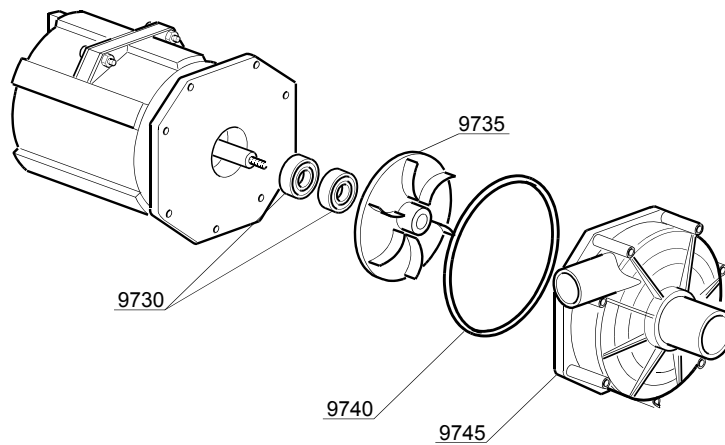
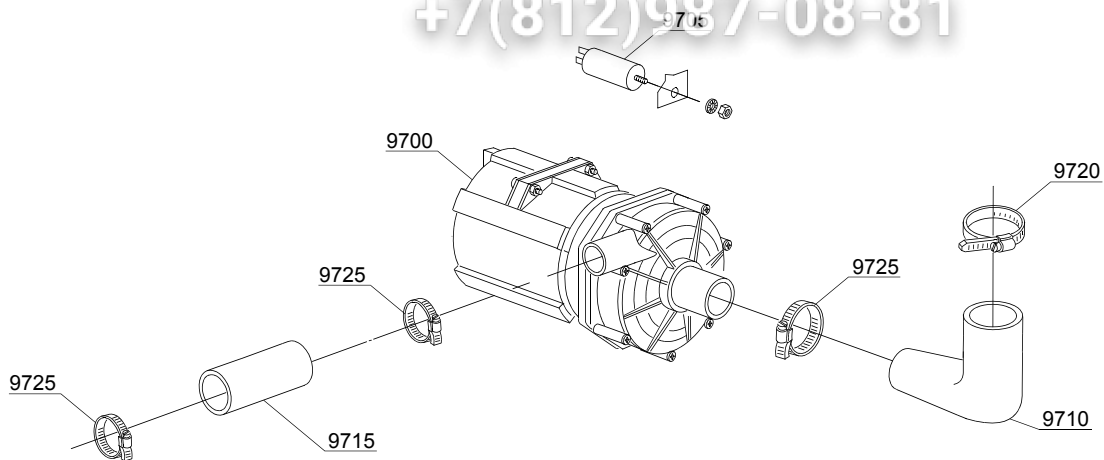

13_003_e

ID	P-code	SN from	SN to	Mod.	Acces	Volt	Description
Module: Wash pump							
9700	16042		-	lw		A	0,40Hp wash pump - 230V 50Hz
9700	16042/C		-	lw			0,40Hp - 110Vac 60Hz wash pump
9705	16043		-	lw			8 uF condenser
9710	16170		-	lw			Suction pipe coupling
9715	10718		-	lw			Pump pipe coupling
9720	11806		-	lw			25/40 clamp (minimum 2 pieces)
9725	11810		-	lw			40/60 clamp (minimum 2 pieces)
9730	15080		-	lw			Rotating seals
9735	7135		-	lw			O-ring
9740	7130		-	lw			Pump rotor (minimum 2 pieces)
9745	7133		-	lw			Scroll

em=ELECTROMECHANICAL SWITCHES, lw=LOWER WASHING, uw=LOWER AND UPPER WASHING

6U=6U

bt=BREAK TANK, bp=BOOSTER PUMP, dvgw=DVGW, cr=COLD RINSE, ws=WATER SOFTNER, dd=DETERGENT DISPENSER, dp=DRAIN PUMP

A=3/N/PE~380-400V 50-60Hz, D=3/PE~200-210V 50-60Hz, F=2/PE~220-240V 50-60Hz, G=3/N/PE~415V 50-60Hz, H=3/PE~220-230V 50-60Hz, K=3/PE~380-400V 50-60Hz, L=3/PE~415V 50-60Hz, M=3/PE~440V 60Hz, P=1/N/PE~220-230V 50-60Hz, R=2/PE~220-240V 50-60Hz, U=1/N/PE~240V 50-60Hz, V=3/PE~240V 50-60Hz, W=1/N/PE~100-110V 50-60Hz

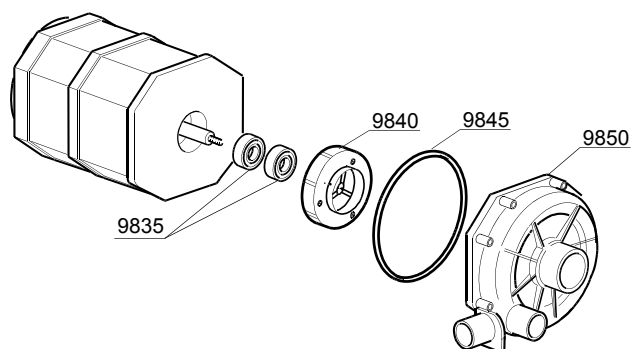
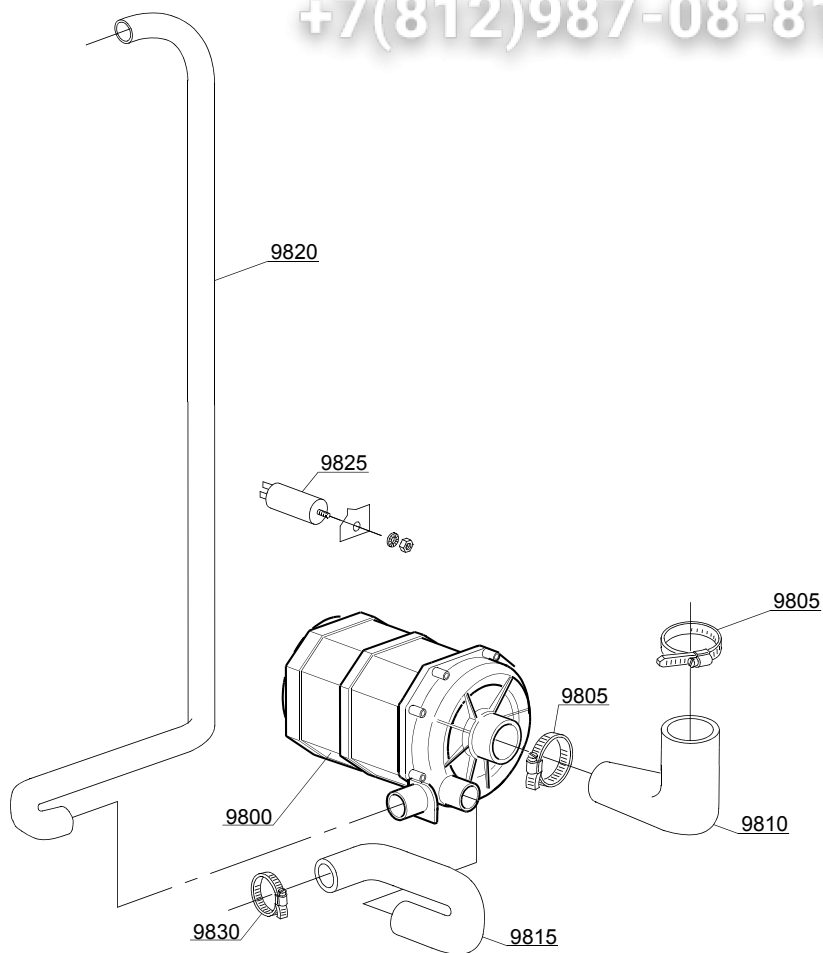

ID	P-code	SN from	SN to	Mod.	Acces.	Volt	Description
Module: Wash pump							
9800	16176		-	uw		A	0,6Hp wash pump - 230V 50Hz
9800	16176/A		-	uw		A	0,6Hp wash pump - 240V 50Hz
9805	11810		-	uw			40/60 clamp (minimum 2 pieces)
9810	16169		-	uw			Suction pipe coupling
9815	16168		-	uw			Lower wash delivery pipe
9820	16167		-	uw			Top delivery pipe
9825	18043		-	uw			10 uF condenser
9830	11806		-	uw			25/40 clamp (minimum 2 pieces)
9835	15080		-	uw			Rotating seals
9840	15079		-	uw			Pump rotor
9845	7130		-	uw			O-ring (minimum 2 pieces)
9850	16182		-	uw			Scroll

em=ELECTROMECHANICAL SWITCHES, lw=LOWER WASHING, uw=LOWER AND UPPER WASHING

6U=6U

bt=BREAK TANK, bp=BOOSTER PUMP, dvgw=DVGW, cr=COLD RINSE, ws=WATER SOFTNER, dd=DETERGENT DISPENSER, dp=DRAIN PUMP

A=3/N/PE~380-400V 50-60Hz, D=3/PE~200-210V 50-60Hz, F=2/PE~220-240V 50-60Hz, G=3/N/PE~415V 50-60Hz, H=3/PE~220-230V 50-60Hz, K=3/PE~380-400V 50-60Hz, L=3/PE~415V 50-60Hz, M=3/PE~440V 60Hz, P=1/N/PE~220-230V 50-60Hz, R=2/PE~220-240V 50-60Hz, U=1/N/PE~240V 50-60Hz, V=3/PE~240V 50-60Hz, W=1/N/PE~100-110V 50-60Hz

vsezip.ru

+7(812)987-08-81

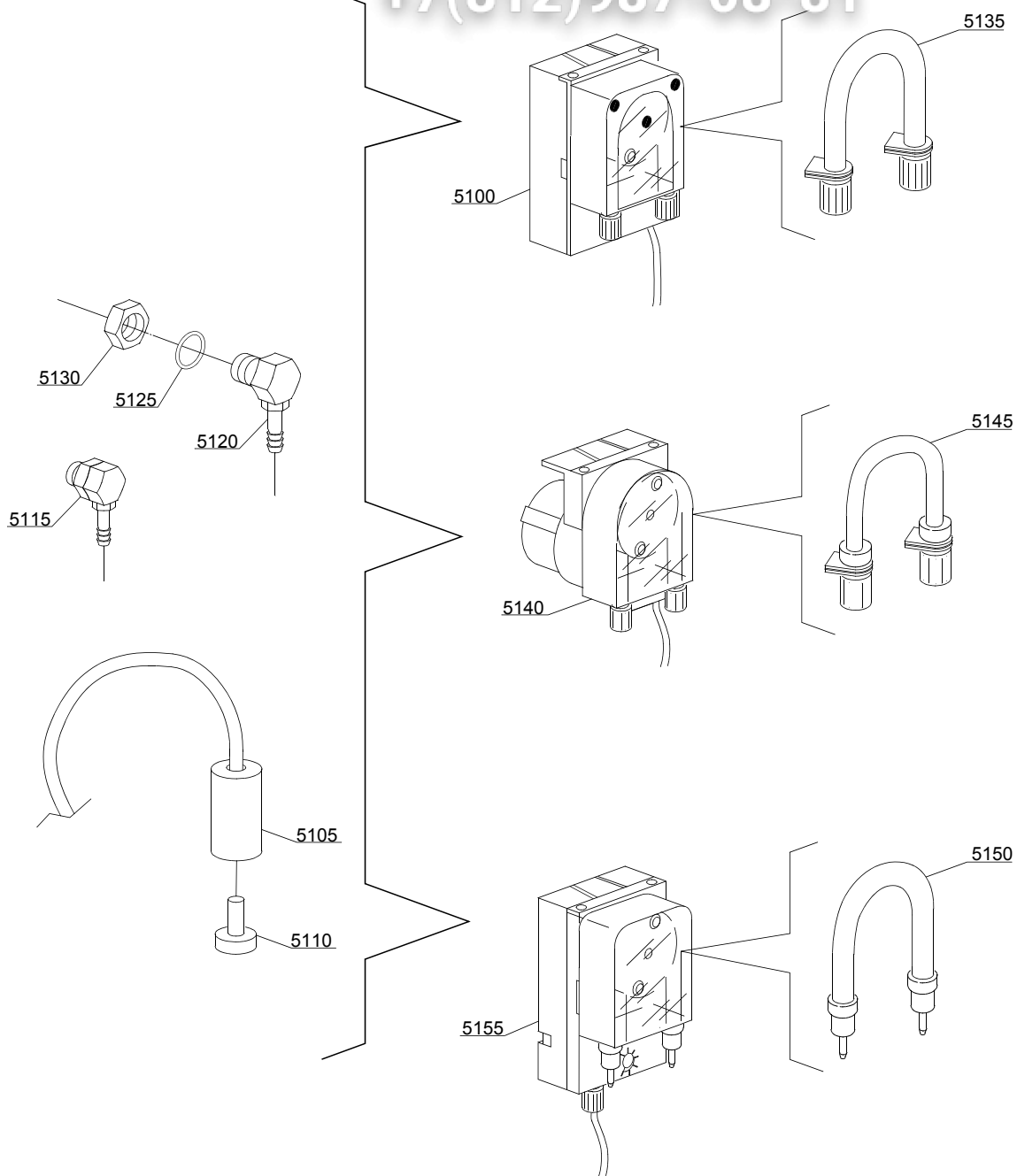

14_004_e

vsezip.ru

ID	P-code	SN from	SN to	Mod.	Acces.	Volt	Description
Module:Dosing detergent group							
5100	15985		-	em	dd		Seko detergent pump
5105	12525		-	em	dd		Counter-weight
5110	15058		-	em	dd		Small filter (minimum 3 pieces)
5115	15123		-	em	dd		Complet plastic injector
5120	15148		-	em	dd		Steel injector
5125	15159		-	em	dd		OR O-ring (minimum 2 pieces)
5130	10200205		-	em	dd		M12x1 stainless steel nut (minimum 2 pieces)
5135	15185		-	em	dd		Seko thermoplastic pipe
5140	15985		-	em	dd		Germac detergent pump
5145	15108/E		-	em	dd		Germac thermoplastic pipe
5150	15985/A		-	em	dd		Plas Cont thermoplastic pipe
5155	15985		-	em	dd		Plas Cont detergent pump

em=ELECTROMECHANICAL SWITCHES, lw=LOWER WASHING, uw=LOWER AND UPPER WASHING

6U=6U

bt=BREAK TANK, bp=BOOSTER PUMP, dvgw=DVGW, cr=COLD RINSE, ws=WATER SOFTNER, dd=DETERGENT DISPENSER, dp=DRAIN PUMP

A=3/N/PE~380-400V 50-60Hz, D=3/PE~200-210V 50-60Hz, F=2/PE~220-240V 50-60Hz, G=3/N/PE~415V 50-60Hz, H=3/PE~220-230V 50-60Hz, K=3/PE~380-400V 50-60Hz, L=3/PE~415V 50-60Hz, M=3/PE~440V 60Hz, P=1/N/PE~220-230V 50-60Hz, R=2/PE~220-240V 50-60Hz, U=1/N/PE~240V 50-60Hz, V=3/PE~240V 50-60Hz, W=1/N/PE~100-110V 50-60Hz

vsezip.ru

+7(812)987-08-81

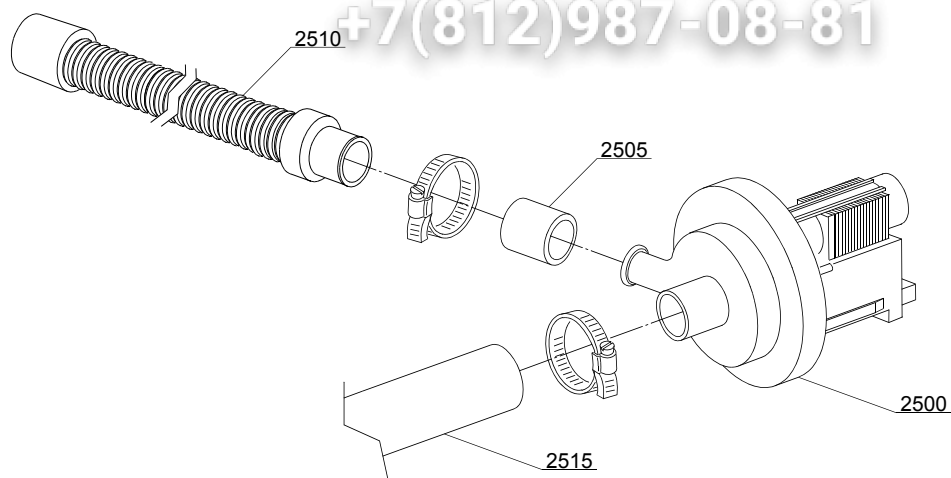

15_004_e

vsezip.ru

ID	P-code	SN from	SN to	Mod	Acces.	Volt	Description
Module: Drain pump group							
2500	15101		-		dp		Drain pump 220/240V 50Hz
2505	15101/D		-		dp		Pipe fitting (minimum 3 pieces)
2510	10727		-		dp		Drain pipe
2515	10718		-		dp		Drain coude/pump connection pipe

em=ELECTROMECHANICAL SWITCHES, lw=LOWER WASHING, uw=LOWER AND UPPER WASHING

6U=6U

bt=BREAK TANK, bp=BOOSTER PUMP, dvgw=DVGW, cr=COLD RINSE, ws=WATER SOFTNER, dd=DETERGENT DISPENSER, dp=DRAIN PUMP

A=3/N/PE~380-400V 50-60Hz, D=3/PE~200-210V 50-60Hz, F=2/PE~220-240V 50-60Hz, G=3/N/PE~415V 50-60Hz, H=3/PE~220-230V 50-60Hz, K=3/PE~380-400V 50-60Hz, L=3/PE~415V 50-60Hz, M=3/PE~440V 60Hz, P=1/N/PE~220-230V 50-60Hz, R=2/PE~220-240V 50-60Hz, U=1/N/PE~240V 50-60Hz, V=3/PE~240V 50-60Hz, W=1/N/PE~100-110V 50-60Hz

vsezip.ru

+7(812)987-08-81

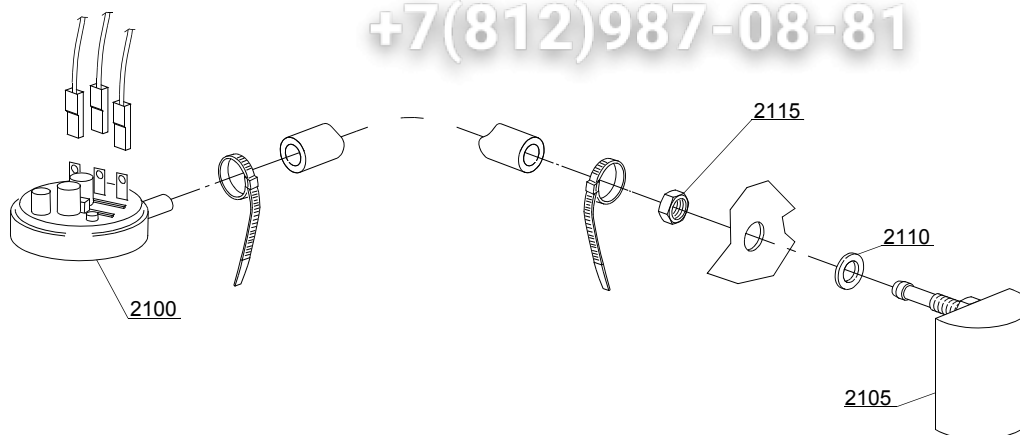

16_001_e

vsezip.ru

ID	P-code	SN from	SN to	Mod.	Acces.	Volt	Description
Module: Pressure switch group with air trap							
2100	10706/A		-	em			47-27 pressure switch
2105	135911/B		-	em			Air-trap assembly
2110	13301		-	em			O-ring (minimum 10 pieces)
2115	11702		-	em			M8 stainless steel nut (minimum 10 pieces)

em=ELECTROMECHANICAL SWITCHES, lw=LOWER WASHING, uw=LOWER AND UPPER WASHING

6U=6U

bt=BREAK TANK, bp=BOOSTER PUMP, dvgw=DVGW, cr=COLD RINSE, ws=WATER SOFTNER, dd=DETERGENT DISPENSER, dp=DRAIN PUMP

A=3/N/PE~380-400V 50-60Hz, D=3/PE~200-210V 50-60Hz, F=2/PE~220-240V 50-60Hz, G=3/N/PE~415V 50-60Hz, H=3/PE~220-230V 50-60Hz, K=3/PE~380-400V 50-60Hz, L=3/PE~415V 50-60Hz, M=3/PE~440V 60Hz, P=1/N/PE~220-230V 50-60Hz, R=2/PE~220-240V 50-60Hz, U=1/N/PE~240V 50-60Hz, V=3/PE~240V 50-60Hz, W=1/N/PE~100-110V 50-60Hz

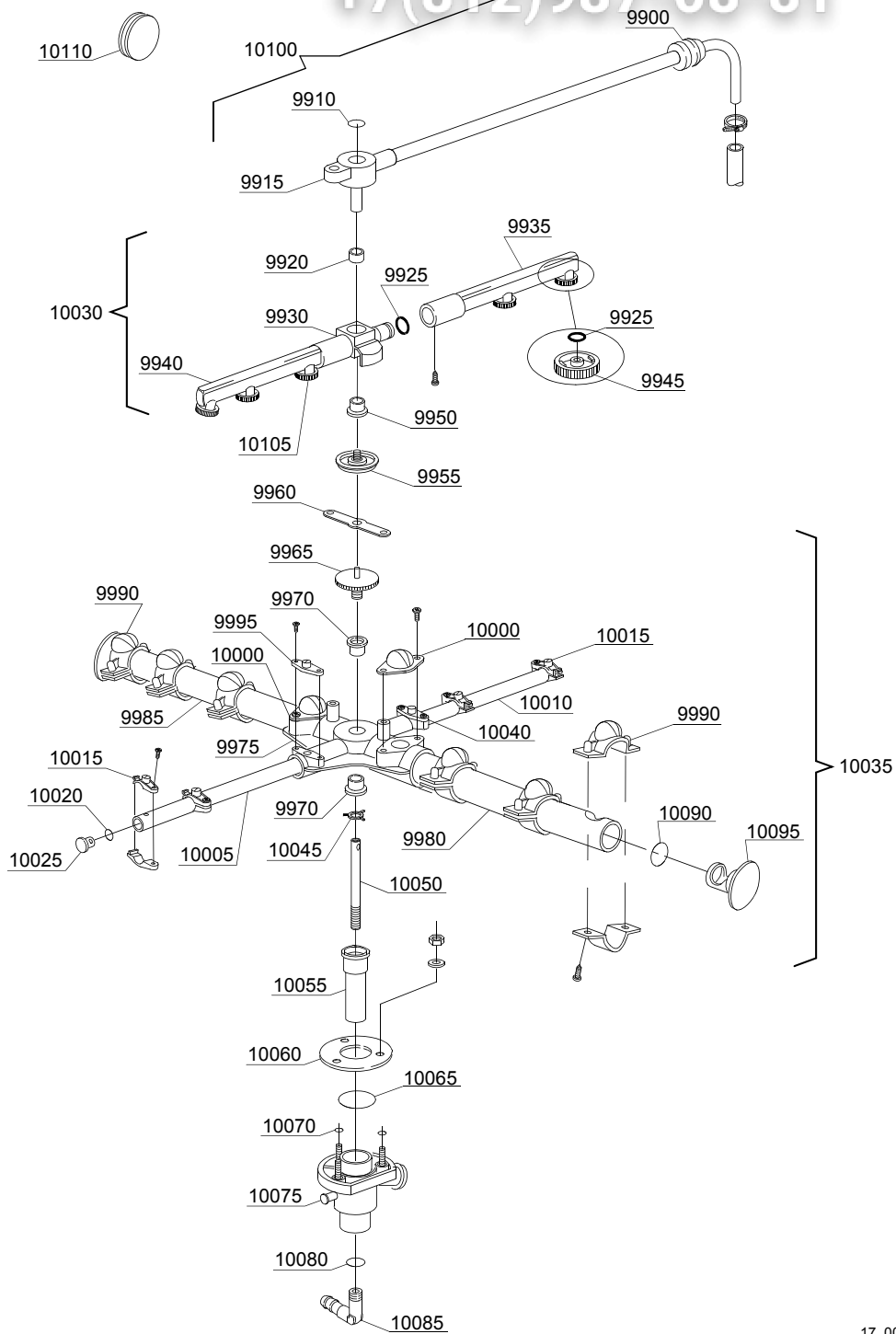

ID	P-code	SN from	SN to	Mod	Acces.	Volt	Description
Module:Turret group with rotating arms							
9900	13304		-	lw			Pipe-pass O-ring
9910	13303		-	lw			10x5x1 plane O-ring (minimum 10 pieces)
9920	13320		-	lw			Sliding washer (minimum 3 pieces)
9925	13002		-	lw			OR R6 NBR O-ring (minimum 10 pieces)
9930	10359		-	lw			Rinse rotor
9935	10360		-	lw			Right rinse pipe
9940	10361		-	lw			Left rinse pipe
9945	12537		-	lw			Opened head rinse nozzle (minimum 5 pieces)
9950	13319		-	lw			Sliding washer (minimum 2 pieces)
9955	10365		-	lw			Handle with insert
9960	10210		-	lw			Blocking ring nut rotor plaque
9965	11101/A		-	lw			Stainless steel group fixing screw
9970	13319		-	lw			Sliding washer (minimum 2 pieces)
9975	10208		-	lw			4 ways small rotor
9980	16501		-	lw			Right wash pipe
9985	16502		-	lw			Left wash pipe
9990	10746		-	lw			Nozzle with horizontal fissure (minimum 3 pieces)
9995	10213		-	lw			Ø10 opened plane nozzle (minimum 2 pieces)
10000	10212		-	lw			Ø18 opened plane nozzle (minimum 2 pieces)
10005	16503		-	lw			Right rinse pipe
10010	16504		-	lw			Left rinse pipe
10015	12528		-	lw			Ø10 complet rinse nozzle (minimum 2 pieces)
10020	13016		-	lw			2018 OR 103 NBR O-ring (minimum 10 pieces)
10025	12532		-	lw			Ø10 plastic plug (minimum 3 pieces)
10035	16951	4022263	-	lw			Lower wash/rinse group
10035	16950		4022262	lw			Lower wash/rinse group
10040	10217		-	lw			Ø10 closed plane nozzle (minimum 2 pieces)
10045	10203		-	lw			Guide pipe

em=ELECTROMECHANICAL SWITCHES, lw=LOWER WASHING, uw=LOWER AND UPPER WASHING

6U=6U

bt=BREAK TANK, bp=BOOSTER PUMP, dvgw=DVGW, cr=COLD RINSE, ws=WATER SOFTNER, dd=DETERGENT DISPENSER, dp=DRAIN PUMP

A=3/N/PE~380-400V 50-60Hz, D=3/PE~200-210V 50-60Hz, F=2/PE~220-240V 50-60Hz, G=3/N/PE~415V 50-60Hz, H=3/PE~220-230V 50-60Hz, K=3/PE~380-400V 50-60Hz, L=3/PE~415V 50-60Hz, M=3/PE~440V 60Hz, P=1/N/PE~220-230V 50-60Hz, R=2/PE~220-240V 50-60Hz, U=1/N/PE~240V 50-60Hz, V=3/PE~240V 50-60Hz, W=1/N/PE~100-110V 50-60Hz

vsezip.ru

+7(812)987-08-81

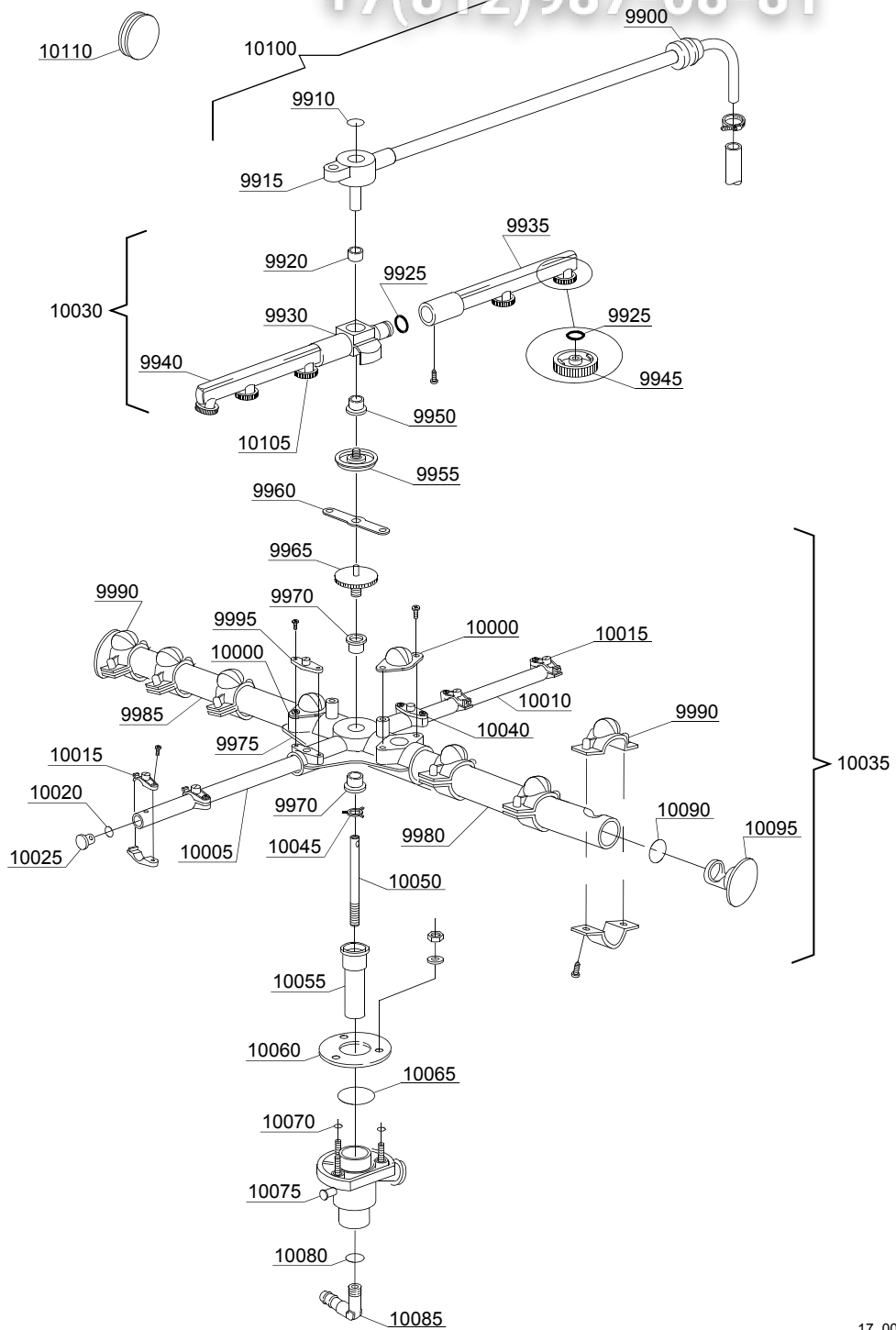

17_002_e

vsezip.ru

ID	P-code	SN from	SN to	Mod.	Acces.	Volt	Description
Module:Turret group with rotating arms							
10050	16039		-	lw			Ø10x1,5x185 steel ground shaft
10055	16250		-	lw			Bell-shape assembly with pipe coupling
10060	16038		-	lw			Ø60 stainless steel disk
10065	13000		-	lw			OR 3125 NBR O-ring (minimum 5 pieces)
10070	13001		-	lw			OR 104 NBR O-ring (minimum 10 pieces)
10075	10205/A		-	lw			Lower wash turret with hole
10080	13003		-	lw			OR 112 NBR O-ring (minimum 10 pieces)
10085	12030		-	lw			3/8M Ø12 elbow pipe fitting
10090	13009		-	lw			OR 2050 NBR O-ring (minimum 40 pieces)
10095	10256		-	lw			Ø18 plastic plug (minimum 2 pieces)
10100	16993		-	lw			Top rinse turret group
10105	12538		-	lw			Closed head rinse nozzle (minimum 3 pieces)
10110	13316/A		-	lw			DVGW hole O-ring

em=ELECTROMECHANICAL SWITCHES, lw=LOWER WASHING, uw=LOWER AND UPPER WASHING
6U=6U

bt=BREAK TANK, bp=BOOSTER PUMP, dvgw=DVGW, cr=COLD RINSE, ws=WATER SOFTNER, dd=DETERGENT DISPENSER, dp=DRAIN PUMP

A=3/N/PE~380-400V 50-60Hz, D=3/PE~200-210V 50-60Hz, F=2/PE~220-240V 50-60Hz, G=3/N/PE~415V 50-60Hz, H=3/PE~220-230V 50-60Hz, K=3/PE~380-400V 50-60Hz, L=3/PE~415V 50-60Hz, M=3/PE~440V 60Hz, P=1/N/PE~220-230V 50-60Hz, R=2/PE~220-240V 50-60Hz, U=1/N/PE~240V 50-60Hz, V=3/PE~240V 50-60Hz, W=1/N/PE~100-110V 50-60Hz

vsezip.ru

+7(812)987-08-81

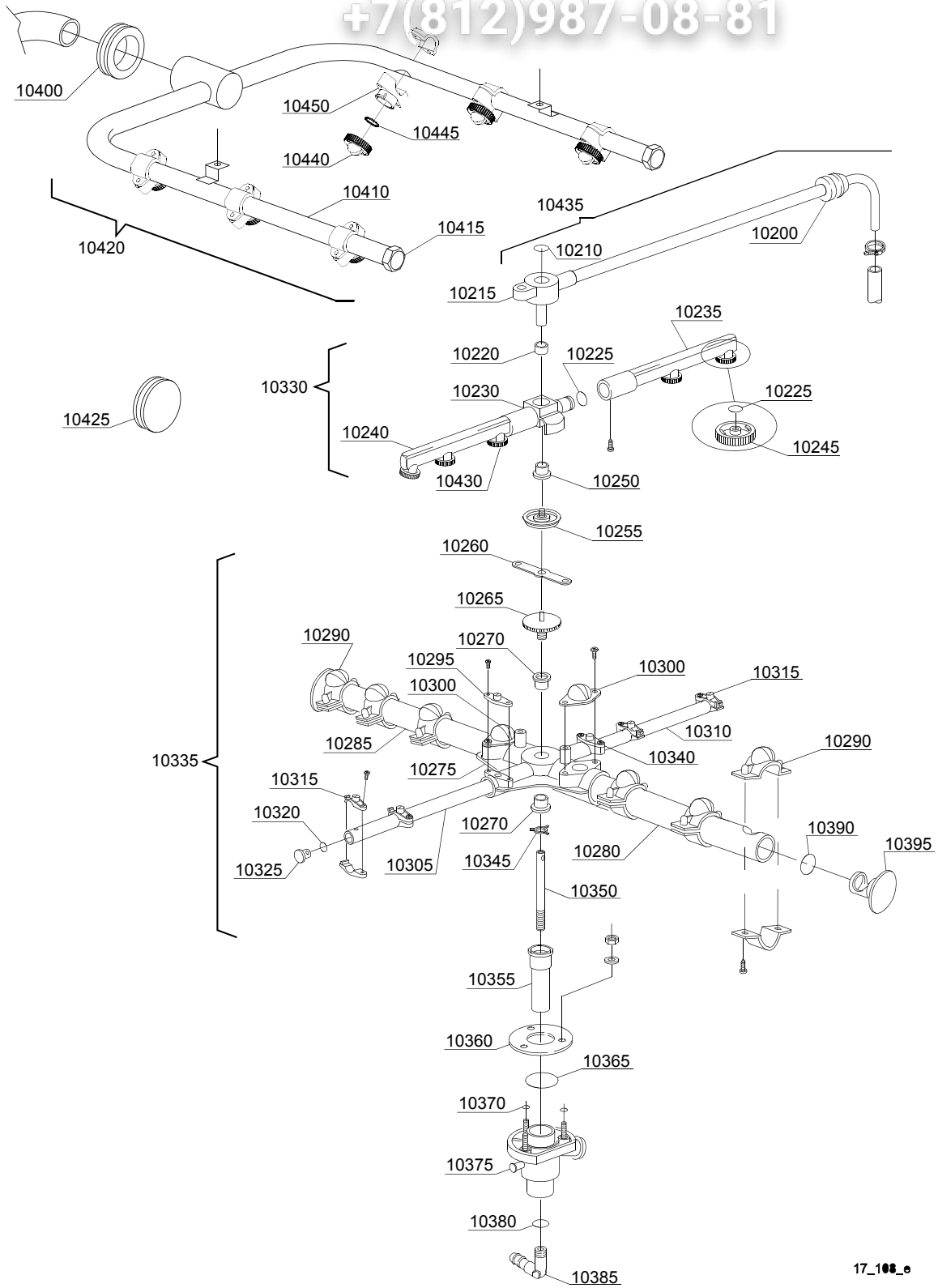

17_100_e

ID	P-code	SN from	SN to	Mod	Acces	Volt	Description
Module:Turret group with rotating arms							
10200	13304		-	uw			Pipe-pass O-ring
10210	13303		-	uw			10x5x1 plane O-ring (minimum 10 pieces)
10220	13320		-	uw			Sliding washer (minimum 3 pieces)
10225	13002		-	uw			OR R6 NBR O-ring (minimum 10 pieces)
10230	10359		-	uw			Rinse rotor
10235	10360		-	uw			Right rinse pipe
10240	10361		-	uw			Left rinse pipe
10245	12537		-	uw			Opened head rinse nozzle (minimum 5 pieces)
10250	13319		-	uw			Sliding washer (minimum 2 pieces)
10255	10365		-	uw			Handle with insert
10260	10210		-	uw			Blocking ring nut rotor plaque
10265	11101/A		-	uw			Stainless steel group fixing screw
10270	13319		-	uw			Sliding washer
10275	10208		-	uw			4 ways small rotor
10280	16501		-	uw			Right wash pipe
10285	16502		-	uw			Left wash pipe
10290	10746		-	uw			Nozzle with horizontal fissure (minimum 3 pieces)
10295	10213		-	uw			Ø10 opened plane nozzle (minimum 2 pieces)
10300	10212		-	uw			Ø18 opened plane nozzle (minimum 2 pieces)
10305	16503		-	uw			Right rinse pipe
10310	16504		-	uw			Left rinse pipe
10315	12528		-	uw			Ø10 complet rinse nozzle (minimum 2 pieces)
10320	13016		-	uw			2018 OR 103 NBR O-ring (minimum 10 pieces)
10325	12532		-	uw			Ø10 plastic plug (minimum 3 pieces)
10330	10996		-	uw			Top rinse group
10335	16951	4022263	-	uw			Lower wash/rinse group
10335	16950		4022262	uw			Lower wash/rinse group
10340	10217		-	uw			Ø10 closed plane nozzle (minimum 2 pieces)

em=ELECTROMECHANICAL SWITCHES, lw=LOWER WASHING, uw=LOWER AND UPPER WASHING

6U=6U

bt=BREAK TANK, bp=BOOSTER PUMP, dvgw=DVGW, cr=COLD RINSE, ws=WATER SOFTNER, dd=DETERGENT DISPENSER, dp=DRAIN PUMP

A=3/N/PE~380-400V 50-60Hz, D=3/PE~200-210V 50-60Hz, F=2/PE~220-240V 50-60Hz, G=3/N/PE~415V 50-60Hz, H=3/PE~220-230V 50-60Hz, K=3/PE~380-400V 50-60Hz, L=3/PE~415V 50-60Hz, M=3/PE~440V 60Hz, P=1/N/PE~220-230V 50-60Hz, R=2/PE~220-240V 50-60Hz, U=1/N/PE~240V 50-60Hz, V=3/PE~240V 50-60Hz, W=1/N/PE~100-110V 50-60Hz

vsezip.ru

+7(812)987-08-81

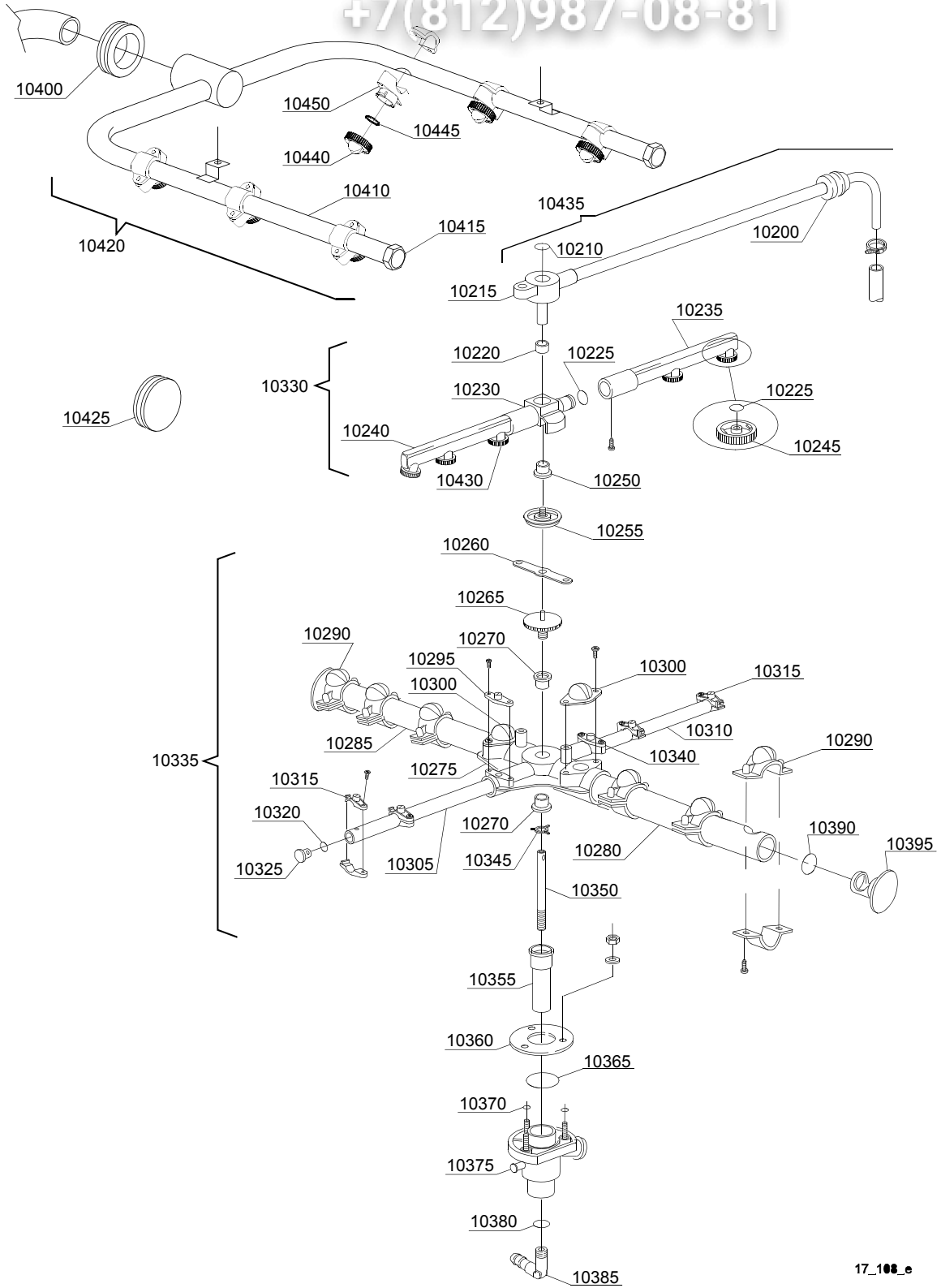

17_108_e

vsezip.ru

ID	P-code	SN from	SN to	Mod	Acces.	Volt	Description
Module:Turret group with rotating arms							
10345	10203		-	uw			Guide pipe
10350	16039		-	uw			Ø10x1,5x185 steel ground shaft
10355	16250		-	uw			Bell-shape assembly with pipe coupling
10360	16038		-	uw			Ø60 stainless steel disk
10365	13000		-	uw			OR 3125 NBR O-ring (minimum 5 pieces)
10370	13001		-	uw			OR 104 NBR O-ring (minimum 10 pieces)
10375	10205/A		-	uw			Lower wash turret with hole
10380	13003		-	uw			OR 112 NBR O-ring (minimum 10 pieces)
10385	12030		-	uw			3/8M Ø12 elbow pipe fitting
10390	13009		-	uw			OR 2050 NBR O-ring (minimum 40 pieces)
10395	10256		-	uw			Ø18 plastic plug (minimum 2 pieces)
10400	13306/A		-	uw			Top wash ramp O-ring
10405	18135		-	uw			Wash nozzle
10410	16161		-	uw			Top wash pipe
10415	12503		-	uw			Plug
10420	16920		-	uw			Top wash group
10425	13316/A		-	uw			DVGW hole O-ring
10430	12538		-	uw			Closed head rinse nozzle (minimum 3 pieces)
10435	16993		-	uw			Top rinse turret group

em=ELECTROMECHANICAL SWITCHES, lw=LOWER WASHING, uw=LOWER AND UPPER WASHING
6U=6U

bt=BREAK TANK, bp=BOOSTER PUMP, dvgw=DVGW, cr=COLD RINSE, ws=WATER SOFTNER, dd=DETERGENT DISPENSER, dp=DRAIN PUMP

A=3/N/PE~380-400V 50-60Hz, D=3/PE~200-210V 50-60Hz, F=2/PE~220-240V 50-60Hz, G=3/N/PE~415V 50-60Hz, H=3/PE~220-230V 50-60Hz, K=3/PE~380-400V 50-60Hz, L=3/PE~415V 50-60Hz, M=3/PE~440V 60Hz, P=1/N/PE~220-230V 50-60Hz, R=2/PE~220-240V 50-60Hz, U=1/N/PE~240V 50-60Hz, V=3/PE~240V 50-60Hz, W=1/N/PE~100-110V 50-60Hz