

Зип Общепит

vsezip.ru

+7(812)987-08-81

DISHWASHER

ELECTRONICAL SWITCHES
LOWER AND UPPER WASHING
INSULATED MODEL

TYPE: 20S5

Accessories
BREAK TANK
BOOSTER PUMP
DVGW
WATER SOFTNER
DETERGENT DISPENSER
DRAIN PUMP

Spare Parts Manual

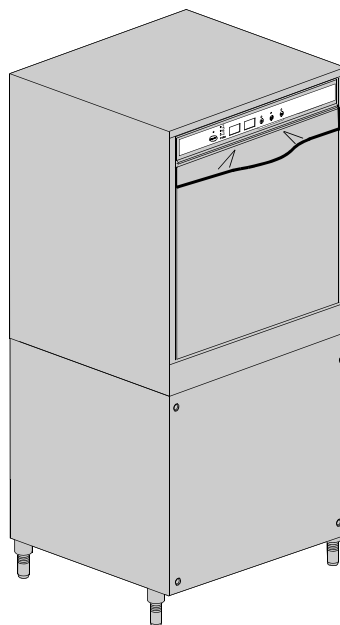

INFORMAZIONI GENERALI

Questo catalogo serve per richiedere con esattezza le parti di ricambio

Nelle ordinazioni indicare:

1) il numero dei codici dei particolari seguito dalla descrizione e la quantità desiderata;

2) Il codice alfa-numerico presente nella seconda colonna della tabella ;

I disegni delle parti di ricambio sono solo indicativi e non rappresentano il pezzo in oggetto.

I dati contenuti in questo catalogo sono indicativi e possono essere soggetti a modifiche senza impegno di preavviso.

ALLGEMEINE INFORMATIONEN

Dieser Ersatzteilkatalog dient zur genauen Angabe der Teile bei Ersatzteilbestellungen.

Bei Ersatzbestellung ist folgendes anzugeben:

1) Die Bestellnummer der Ersatzteile mit der entsprechenden Beschreibung genaue Menge;

2) Der alpha-numerischer Code auf der zweiten Reihe in dein Schuld;

Die Zeichnungen der Ersatzteile sind nur als Hinweise gedacht und stellen nicht das betroffene Teil dar.

Bei den im Katalog angeführten Daten handelt es sich um Anhaltsdaten, die jederzeit, ohne Vorankündigung, geändert werden können.

GENERAL INFORMATION

The present spare parts order exactly the right spare parts

When ordering specify:

1) the part's code number followed by its description and quantity needed;

2) The alpha-numeric code is in the second column in the chart;

Spare parts drawings are general and do not represent the part.

The contents of this catalogue are general and can undergo changes without prior notice.

INFORMACIONES GENERALES

El presente catálogo sirve para pedir con exactitud las partes de repuesto

En los pedidos se debe indicar:

1) el número de código de la parte y a continuación la descripción cantidad deseada;

2) El código alfanumerico presente en la segnada columna de la tabla;

Los diseños de las partes de recambio son solo indicativos y no representan la pieza en cuestión.

Los datos contenidos en el presente catálogo son indicativos y pueden modificarse sin aviso previo.

INFORMATIONS GENERALES

Ce catalogue permet de commander correctement les pièces détachées

Les commandes doivent être passées en indiquant:

1) le numero de code des pièces détachées suivi de leur description quantité désirée;

2) le code alphanumérique dans la deuxième colonne du tableau;

Les plans des pièces détachées sont fournis seulement à titre indicatif et ne représentent pas la pièce concernée.

Les données de ce catalogue sont citées seulement à titre indicatif et peuvent être l'objet de modifications sans avis préalable.

**ESEMPIO
EXAMPLE
EXEMPLE
BEISPIEL**

Rif.	Codici
MODULE:Particolari	
10505	540903
10510	540908
10515	15065/A
10520	540086
10525	540028



Note

Tutte le informazioni riportate si intendono aggiornate alla data di stampa. Il Produttore si riserva il diritto di apportare qualsiasi modifica richiesta dallo sviluppo evolutivo dei suddetti prodotti.

Per la sicurezza, la garanzia, l'affidabilità ed il valore della lavastoviglie usa solo ricambi originali. **Per alcuni codici, sono richieste quantità minime d'ordine.**



Attenzione

Questo libretto è parte integrante della lavastoviglie e, in caso di passaggio di proprietà, deve essere consegnato al nuovo acquirente.



Remarque

Toutes les informations contenues dans ce manuel s'entendent mises à jour à la date d'impression. En raison du développement constant de ses produits, usine se réserve le droit d'apporter à tout instant les modifications qu'elle jugera utiles.

Pour la sécurité, la garantie, la fiabilité et la valeur de votre lavevaisselles n'utilisez que des pièces de rechange d'origine. **Pour quelque référence on demande un minimum de pièces par commande**



Attention

Ce manuel doit être considéré comme partie intégrante de la lavevaisselles, en cas de transfert de propriété, doit toujours être remis au nouveau propriétaire.



Note

The information contained herein is valid at the time of going to print. The Company reserves the right to make any changes required by the future development of the above-mentioned products.

For your safety, as well as to preserve the warranty reliability and worth of your dishwashers, use original spare parts only. **For some codes a minimum quantity for order is required.**



Warning

This manual forms an integral part of the dishwashers and - if a transfer of title occurs - must always be handed over to the new owner.



Hinweis

Die Der Hersteller behält sich das Recht vor, jegliche, durch eine Weiterentwicklung der genannten Produkte bedingte Änderungen vornehmen zu können.

Verwenden Sie für Ihre Sicherheit, die Garantie, die Zuverlässigkeit und den Wert Ihrer machine originale Ersatzteile. **Für bestimmte Code nummer werden mindesten bestellungen verlangt.**



Achtung

Diese Betriebsanleitung ist Bestandteile des machine und muss bei seinem Weiterverkauf dem neuen Besitzer ausgehändigt werden.



+7(812)987-08-81



Code DW 999XYYYY **CL/Part**

Model DESCRIPTION

S/N DW A 1015770 Type

400V 3N 50HZ 8A
3500W 500W

 16A

IPX3

Pressione Dinamica alimentazione idrica 200-500 kPa
Pression dynamique arrivée d'eau
Dynamic pressure water supply
Dynamischer Druck asserreinlauf

Pressione dinamica vapore saturo
Pression dynamique vapore satueèè
Dymanischer Druck gesattigter Dampf
Pression Dinamica Vapor Saturado

TECHICAL SPECIFICATION



MADE IN ITALY

Temperatura massima acqua in ingresso 60°C
Temperature max eau a l'entre
Maximale Temperatur Wasseranschlü
Maximum Water temperature in-feeding

Model 

S/N 



Spare parts

Зип Общепит

vsezip.ru

+7(812)987-08-81

vsezip.ru

+7(812)987-08-81

1. Spare parts

General body parts.....	9
Lockup system	11
Electric control components.....	13
Command electronic control	15
Solenoid valve group	17
Solenoid valve group	19
Break Tank	21
Rinse with steady temperature.....	23
Booster pump.....	25
Booster pump.....	27
DVGW	29
Water softner group.....	31
Rinse aid dispenser group.....	33
Boiler group	35
3 ways connection	37
Wash pump	39

Dosing detergent group 41

Drain pump group 43

Pressure switch group with air trap ... 45

Turret group with rotating arms 47

Turret group with rotating arms 49

1.1 Voltage codes

Volt	Voltage code
A	3/N/PE~380-400V 50-60Hz
D	3/PE~200-210V 50-60Hz
F	2/PE~220-240V 50-60Hz
G	3/N/PE~415V 50-60Hz
H	3/PE~220-230V 50-60Hz
K	3/PE~380-400V 50-60Hz
L	3/PE~415V 50-60Hz
M	3/PE~440V 60Hz
P	1/N/PE~220-230V 50-60Hz
R	2/PE~220-240V 50-60Hz
U	1/N/PE~240V 50-60Hz
V	3/PE~240V 50-60Hz
W	1/N/PE~100-110V 50-60Hz

1.2 Product codes

Product code	Full name
Model codes	
e	ELECTRONICAL SWITCHES
uw	LOWER AND UPPER WASHING
i	INSULATED MODEL
Type codes	
20S5	20S5
Accessory codes	
bt	BREAK TANK
bp	BOOSTER PUMP
dvgw	DVGW
ws	WATER SOFTNER
dd	DETERGENT DISPENSER
dp	DRAIN PUMP

vsezip.ru

+7(812)987-08-81

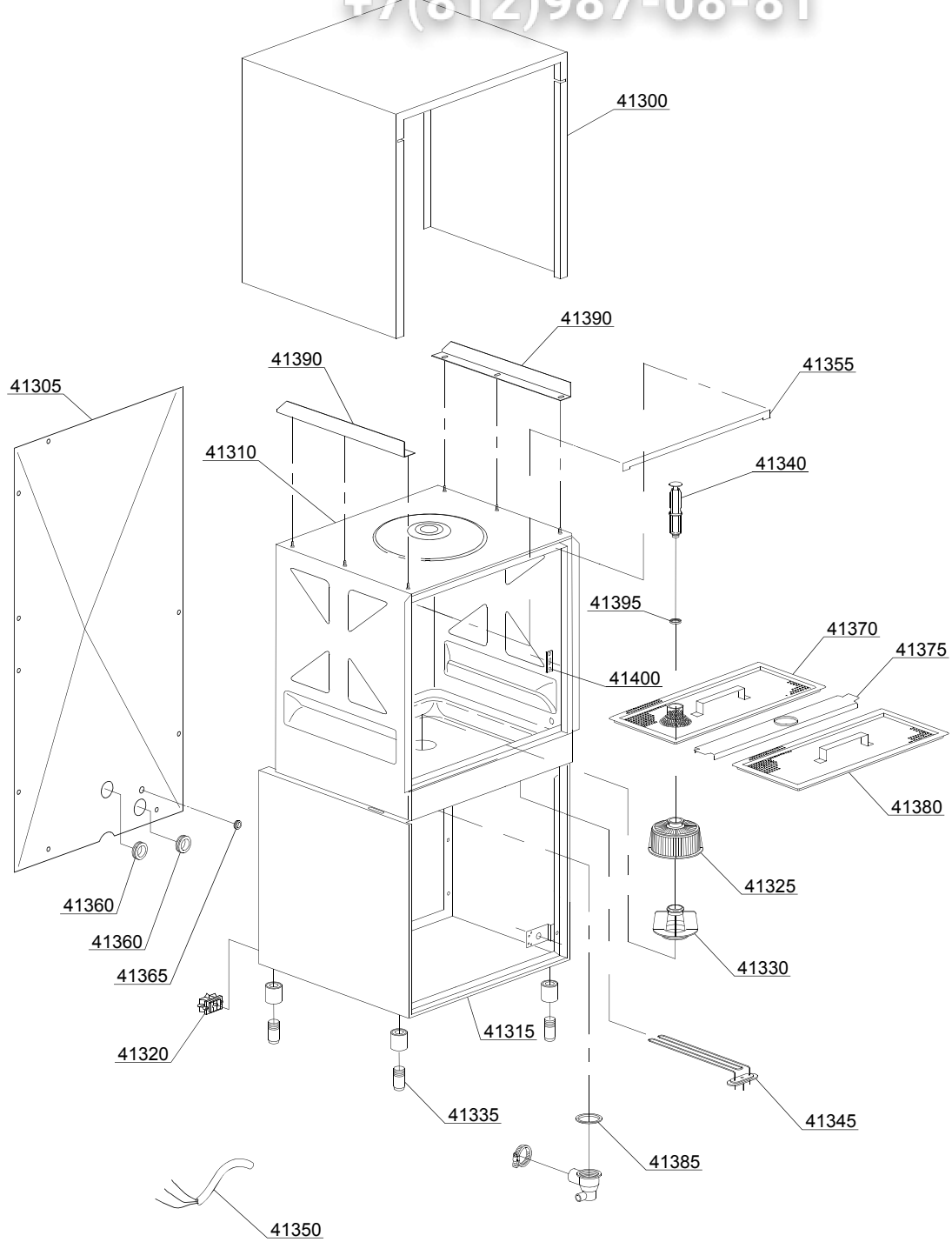

01_035_e

vsezip.ru

ID	P-code	SN from	SN to	Mod	Acces	Volt	Description
Module:General body parts							
41300	550944		-	e			Cover
41305	550945		-	e			Back panel
41310	550900		-	e			Body
41315	550903		-	e			Steel base
41315	550937		-	e			Body assembly + steel base
41320	15065/A		-	e			Cable-fastener with screw
41325	500616		-	e			Suction filter
41330	500615		-	e			Ferrule with filter
41335	15116		-	e			Foot
41340	500619		-	e			Overflow pipe
41345	150047		-	e			2,7/2,94KW 230/240V heating element
41350	80200		-	e			5x4x3400 cable
41355	550207		-	e			Door ledge O-ring
41360	13324		-	e			Ø46 mm lead through rubber
41365	13323		-	e			D.13mm dosing pipe pass (minimum 2 pieces)
41370	550912		-	e			Surface filter for overflow
41375	75926		-	e			Sleeper holder-filter
41380	75626		-	e			Surface half-filter
41385	80208		-	e			95x75x3 O-ring (minimum 2 pieces)
41390	550947		-	e			Right/left internal slide
41395	13021		-	e			DEM 40 O-ring (minimum 2 pieces)
41400	150401		-	e			Door rod slide (minimum 4 pieces)

e=ELECTRONICAL SWITCHES, uw=LOWER AND UPPER WASHING, i=INSULATED MODEL

20S5=20S5

bt=BREAK TANK, bp=BOOSTER PUMP, dvgw=DVGW, ws=WATER SOFTNER, dd=DETERGENT DISPENSER, dp=DRAIN PUMP

A=3/N/PE~380-400V 50-60Hz, D=3/PE~200-210V 50-60Hz, F=2/PE~220-240V 50-60Hz, G=3/N/PE~415V 50-60Hz, H=3/PE~220-230V 50-60Hz, K=3/PE~380-400V 50-60Hz, L=3/PE~415V 50-60Hz, M=3/PE~440V 60Hz, P=1/N/PE~220-230V 50-60Hz, R=2/PE~220-240V 50-60Hz, U=1/N/PE~240V 50-60Hz, V=3/PE~240V 50-60Hz, W=1/N/PE~100-110V 50-60Hz

vsezip.ru

+7(812)987-08-81

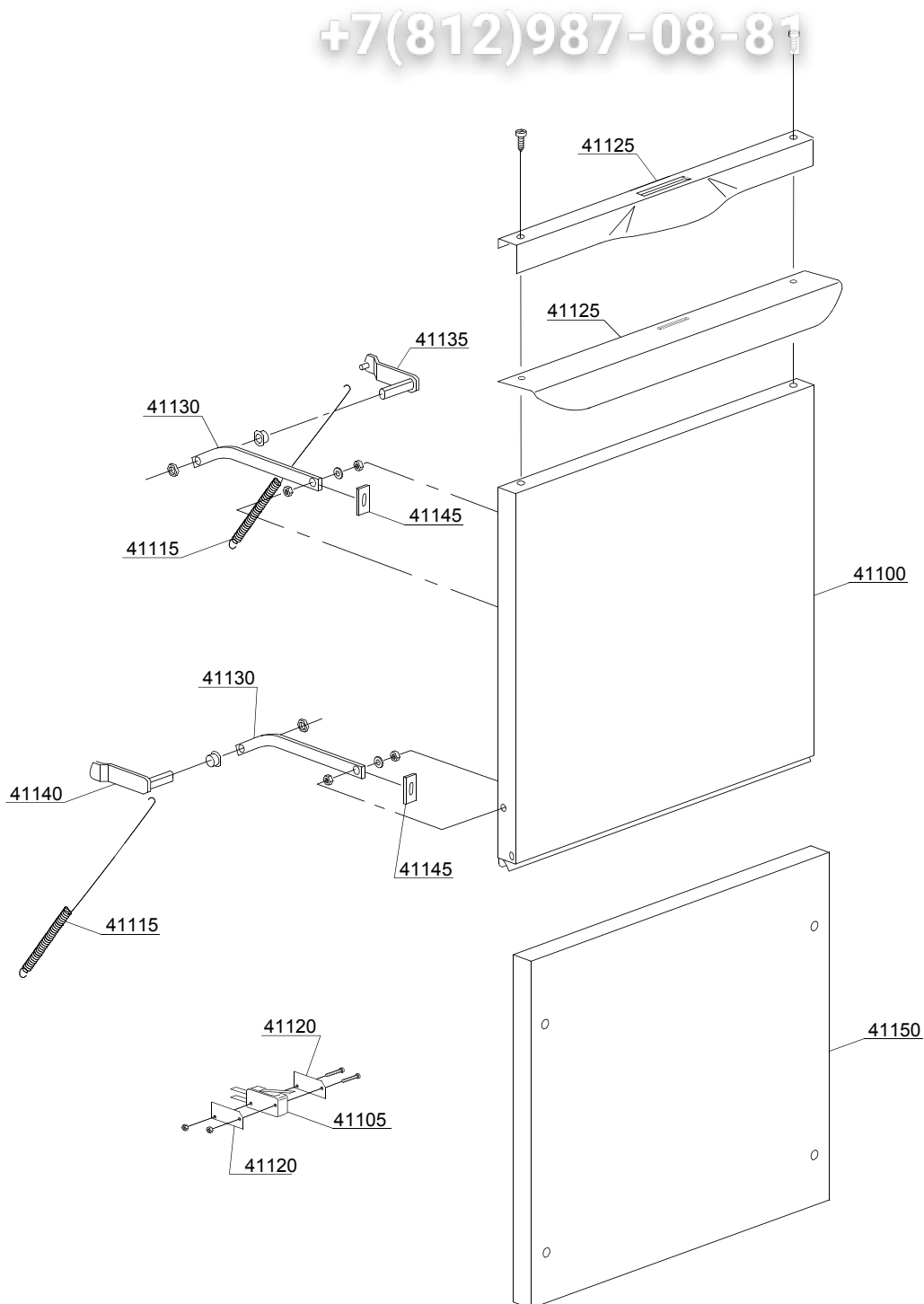

02_306ae

vsezip.ru

ID	P-code	SN from	SN to	Mod.	Acces.	Volt	Description
Module: Lockup system							
41100	550950		-	e			Door
41105	10704		-	e			Door microswitch
41115	550212		-	e			Long spring door
41120	10770		-	e			Insulation for door microswitch (minimum 3 pieces)
41125	550939		-	e			Steel handle
41125	550917		-	e			Serie "S" steel handle
41130	150221/A		-	e			Door rod
41135	550908		-	e			Right hinge door
41140	550909		-	e			Left hinge door
41145	135222		-	e			Hinge door seal
41150	550955		-	e			Under door
41150	550956		-	e			Under door
41150	550957		-	e			Under door

e=ELECTRONICAL SWITCHES, uw=LOWER AND UPPER WASHING, i=INSULATED MODEL

20S5=20S5

bt=BREAK TANK, bp=BOOSTER PUMP, dvgw=DVGW, ws=WATER SOFTNER, dd=DETERGENT DISPENSER, dp=DRAIN PUMP

A=3/N/PE~380-400V 50-60Hz, D=3/PE~200-210V 50-60Hz, F=2/PE~220-240V 50-60Hz, G=3/N/PE~415V 50-60Hz, H=3/PE~220-230V 50-60Hz, K=3/PE~380-400V 50-60Hz, L=3/PE~415V 50-60Hz, M=3/PE~440V 60Hz, P=1/N/PE~220-230V 50-60Hz, R=2/PE~220-240V 50-60Hz, U=1/N/PE~240V 50-60Hz, V=3/PE~240V 50-60Hz, W=1/N/PE~100-110V 50-60Hz

vsezip.ru

+7(812)987-08-81

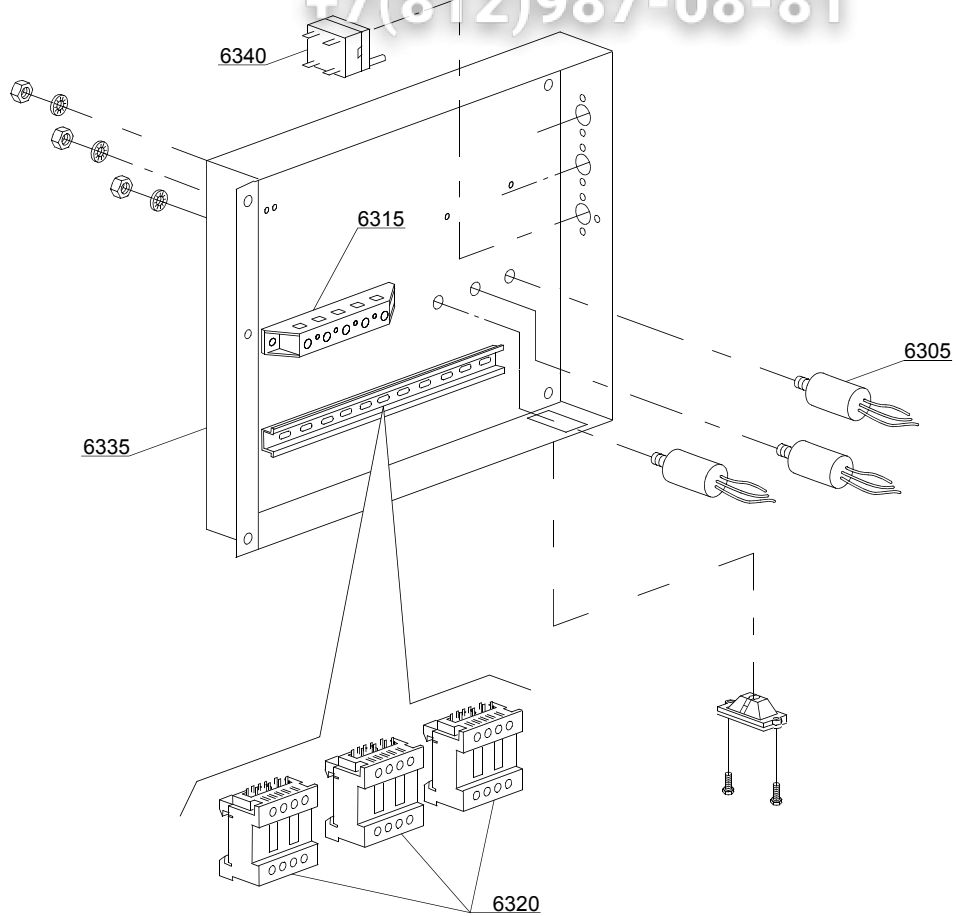

04_008ce

vsezip.ru

ID	P-code	SN from	SN to	Mod	Acces	Volt	Description
Module: Electric control components							
6305	15149		-	e			Low noise filter
6315	500551		-	e			6 poles terminal board
6315	500550		-	e			3 poles terminal board
6320	15086		-	e			Contactactor 230V 50/60Hz 4C
6320	15086/B		-	e			Contactactor 240V 50Hz
6335	550907		-	e			Electric components panel
6340	2000430		-	e			Safety thermostat

e=ELECTRONICAL SWITCHES, uw=LOWER AND UPPER WASHING, i=INSULATED MODEL

20S5=20S5

bt=BREAK TANK, bp=BOOSTER PUMP, dvgw=DVGW, ws=WATER SOFTNER, dd=DETERGENT DISPENSER, dp=DRAIN PUMP

A=3/N/PE~380-400V 50-60Hz, D=3/PE~200-210V 50-60Hz, F=2/PE~220-240V 50-60Hz, G=3/N/PE~415V 50-60Hz, H=3/PE~220-230V 50-60Hz, K=3/PE~380-400V 50-60Hz, L=3/PE~415V 50-60Hz, M=3/PE~440V 60Hz, P=1/N/PE~220-230V 50-60Hz, R=2/PE~220-240V 50-60Hz, U=1/N/PE~240V 50-60Hz, V=3/PE~240V 50-60Hz, W=1/N/PE~100-110V 50-60Hz

vsezip.ru

+7(812)987-08-81

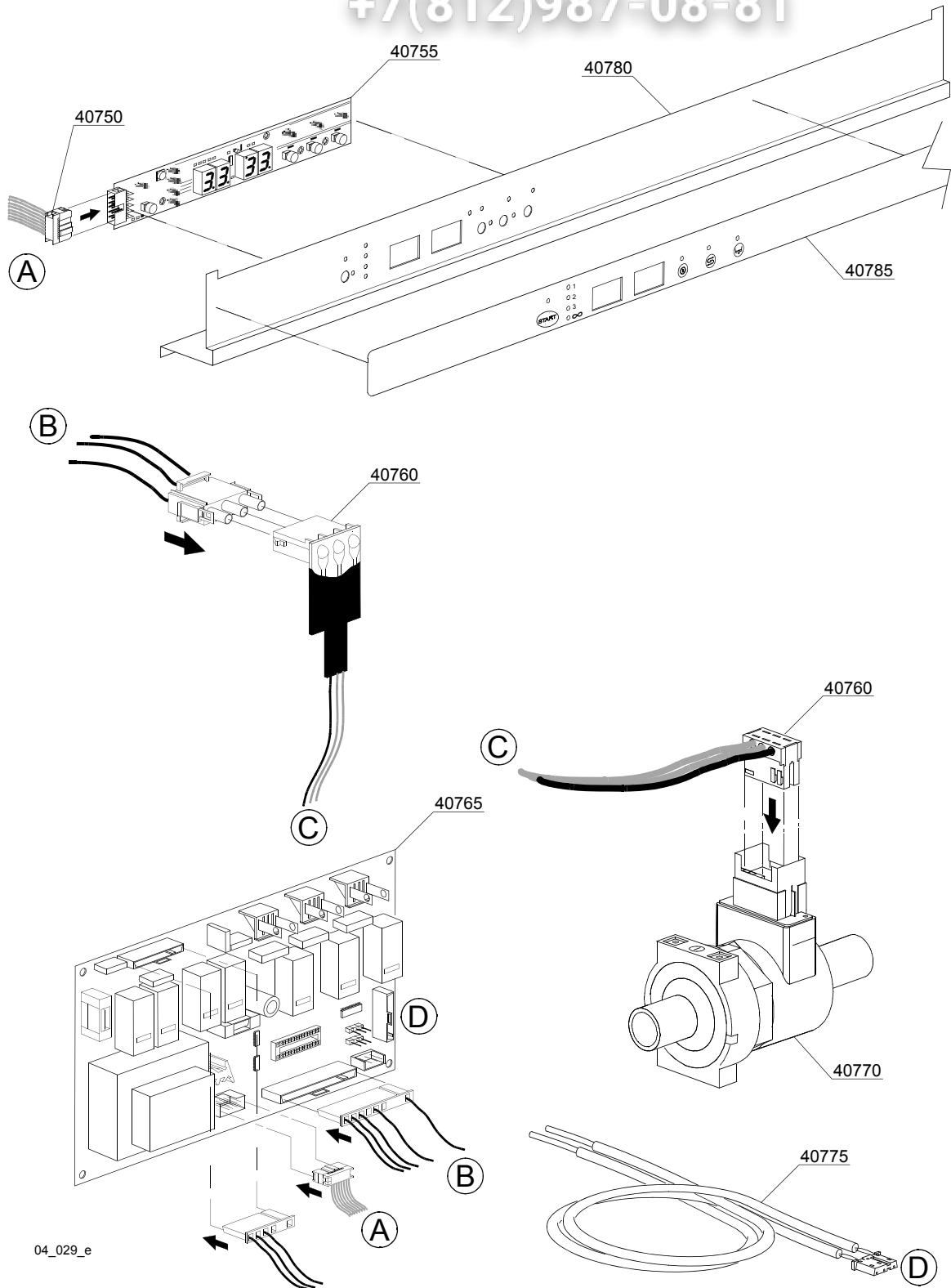

04_029_e

vsezip.ru

ID	P-code	SN from	SN to	Mod	Acces.	Volt	Description
Module: Command electronic control							
40750	50589		-	i,e			Plug L=500mm
40750	50582		-	i,e			Plug L=2300mm
40755	50581		-	i,e			Touche sensitive
40760	50584		-	i,e			Water flow board
40765	50580		-	i,e			Electronic timer+main board
40765	50590		-	i,e			Electronic timer+main board BA
40770	50583		-	i,e			Water flow meter for board
40775	50562		-	i,e			Temperature probe set
40780	550958		-	i,e			Control Panel
40785	560039		-	i,e			Neutral-full Silkscreen processed grill
40785	560035		-	i,e			Full silkscreen processed grill

e=ELECTRONICAL SWITCHES, uw=LOWER AND UPPER WASHING, i=INSULATED MODEL

20S5=20S5

bt=BREAK TANK, bp=BOOSTER PUMP, dvgw=DVGW, ws=WATER SOFTNER, dd=DETERGENT DISPENSER, dp=DRAIN PUMP

A=3/N/PE~380-400V 50-60Hz, D=3/PE~200-210V 50-60Hz, F=2/PE~220-240V 50-60Hz, G=3/N/PE~415V 50-60Hz, H=3/PE~220-230V 50-60Hz, K=3/PE~380-400V 50-60Hz, L=3/PE~415V 50-60Hz, M=3/PE~440V 60Hz, P=1/N/PE~220-230V 50-60Hz, R=2/PE~220-240V 50-60Hz, U=1/N/PE~240V 50-60Hz, V=3/PE~240V 50-60Hz, W=1/N/PE~100-110V 50-60Hz

vsezip.ru

+7(812)987-08-81

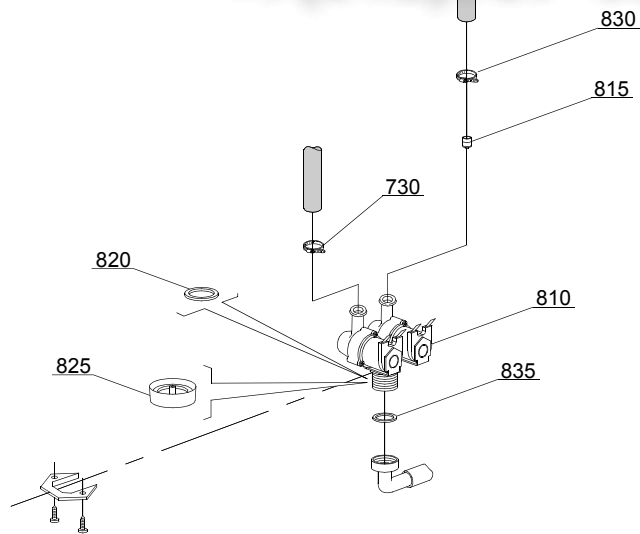

05_003_€

vsezip.ru

ID	P-code	SN from	SN to	Mod.	Acces	Volt	Description
Module:Solenoid valve group							
810	15098		-	i,e	ws		Double solenoid valve - Ø10 - 230Vac
815	15115		-	e,i	ws		Green pression solenoid valve for regeneration (minimum 2 pieces)
820	N.C.		-	e,i	ws		Pression reducing valve
835	13307		-	i,e			3/4 gasket

e=ELECTRONICAL SWITCHES, uw=LOWER AND UPPER WASHING, i=INSULATED MODEL

20S5=20S5

bt=BREAK TANK, bp=BOOSTER PUMP, dvgw=DVGW, ws=WATER SOFTNER, dd=DETERGENT DISPENSER, dp=DRAIN PUMP

A=3/N/PE~380-400V 50-60Hz, D=3/PE~200-210V 50-60Hz, F=2/PE~220-240V 50-60Hz, G=3/N/PE~415V 50-60Hz, H=3/PE~220-230V 50-60Hz, K=3/PE~380-400V 50-60Hz, L=3/PE~415V 50-60Hz, M=3/PE~440V 60Hz, P=1/N/PE~220-230V 50-60Hz, R=2/PE~220-240V 50-60Hz, U=1/N/PE~240V 50-60Hz, V=3/PE~240V 50-60Hz, W=1/N/PE~100-110V 50-60Hz

vsezip.ru

+7(812)987-08-81

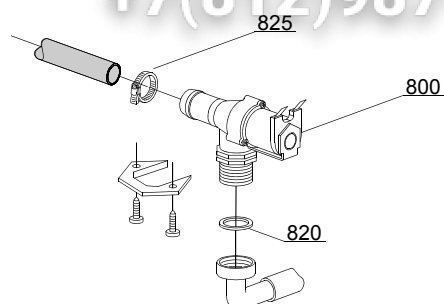

05_005_e

ID	P-code	SN from	SN to	Mod	Acces	Volt	Description
Module:Solenoid valve group							
800	10703		-	e,i			Single solenoid valve - 230Vac
820	N.C.		-	e,i			Pression reducing valve
825	11807		-	e,i			12/22 clamp (minimum 3 pieces)

e=ELECTRONICAL SWITCHES, uw=LOWER AND UPPER WASHING, i=INSULATED MODEL

20S5=20S5

bt=BREAK TANK, bp=BOOSTER PUMP, dvgw=DVGW, ws=WATER SOFTNER, dd=DETERGENT DISPENSER, dp=DRAIN PUMP

A=3/N/PE~380-400V 50-60Hz, D=3/PE~200-210V 50-60Hz, F=2/PE~220-240V 50-60Hz, G=3/N/PE~415V 50-60Hz, H=3/PE~220-230V 50-60Hz, K=3/PE~380-400V 50-60Hz, L=3/PE~415V 50-60Hz, M=3/PE~440V 60Hz, P=1/N/PE~220-230V 50-60Hz, R=2/PE~220-240V 50-60Hz, U=1/N/PE~240V 50-60Hz, V=3/PE~240V 50-60Hz, W=1/N/PE~100-110V 50-60Hz

vsezip.ru

+7(812)987-08-81

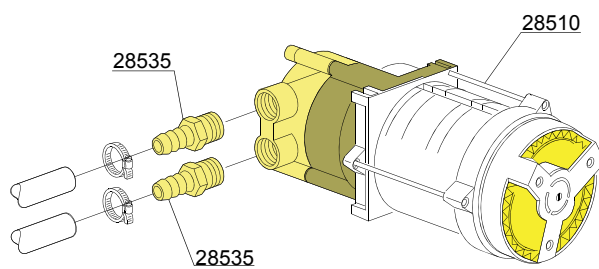
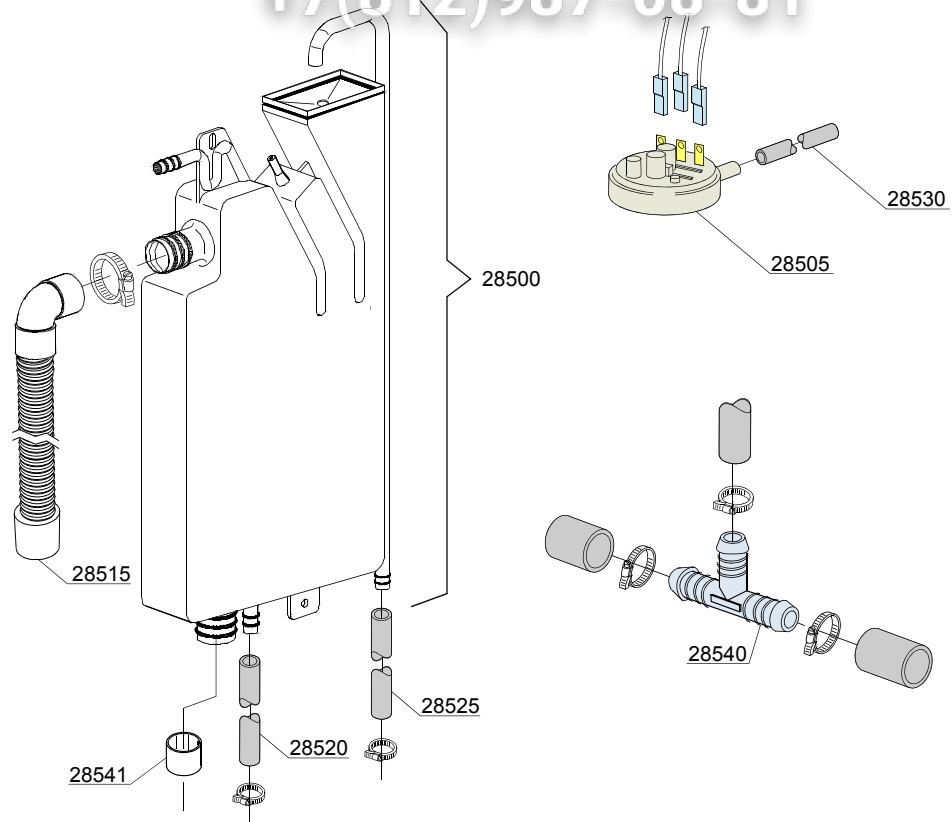

06_004pe

ID	P-code	SN from	SN to	Mod.	Acces.	Volt	Description
Module:Break Tank							
28500	15720		-	e,i	bt		Break tank assembly
28505	10706/A		-	e,i	bt		47-27 pressure switch
28510	15100/D		-	e,i	bt		Booster pump 220/240V - body pumps in brass
28515	15721		-	e,i	bt		BT middle pipe L=920
28520	2907350		-	e,i	bt		12x20 EPDM rubber hose
28525	2907352		-	e,i	bt		PVC WRAS rubber hose
28530	14508		-	e,i	bt		4,5x9 EPDM rubber hose (minimum 2 mt)
28535	10221311		-	e,i	bt		Rubber holder Ø 12 3/8G
28540	540098			e,i	bt		3 ways D25
28541	12533			e,i	bt		Reinforce for pipe in exit (break tank)

e=ELECTRONICAL SWITCHES, uw=LOWER AND UPPER WASHING, i=INSULATED MODEL

20S5=20S5

bt=BREAK TANK, bp=BOOSTER PUMP, dvgw=DVGW, ws=WATER SOFTNER, dd=DETERGENT DISPENSER, dp=DRAIN PUMP

A=3/N/PE~380-400V 50-60Hz, D=3/PE~200-210V 50-60Hz, F=2/PE~220-240V 50-60Hz, G=3/N/PE~415V 50-60Hz, H=3/PE~220-230V 50-60Hz, K=3/PE~380-400V 50-60Hz, L=3/PE~415V 50-60Hz, M=3/PE~440V 60Hz, P=1/N/PE~220-230V 50-60Hz, R=2/PE~220-240V 50-60Hz, U=1/N/PE~240V 50-60Hz, V=3/PE~240V 50-60Hz, W=1/N/PE~100-110V 50-60Hz

06_006ae

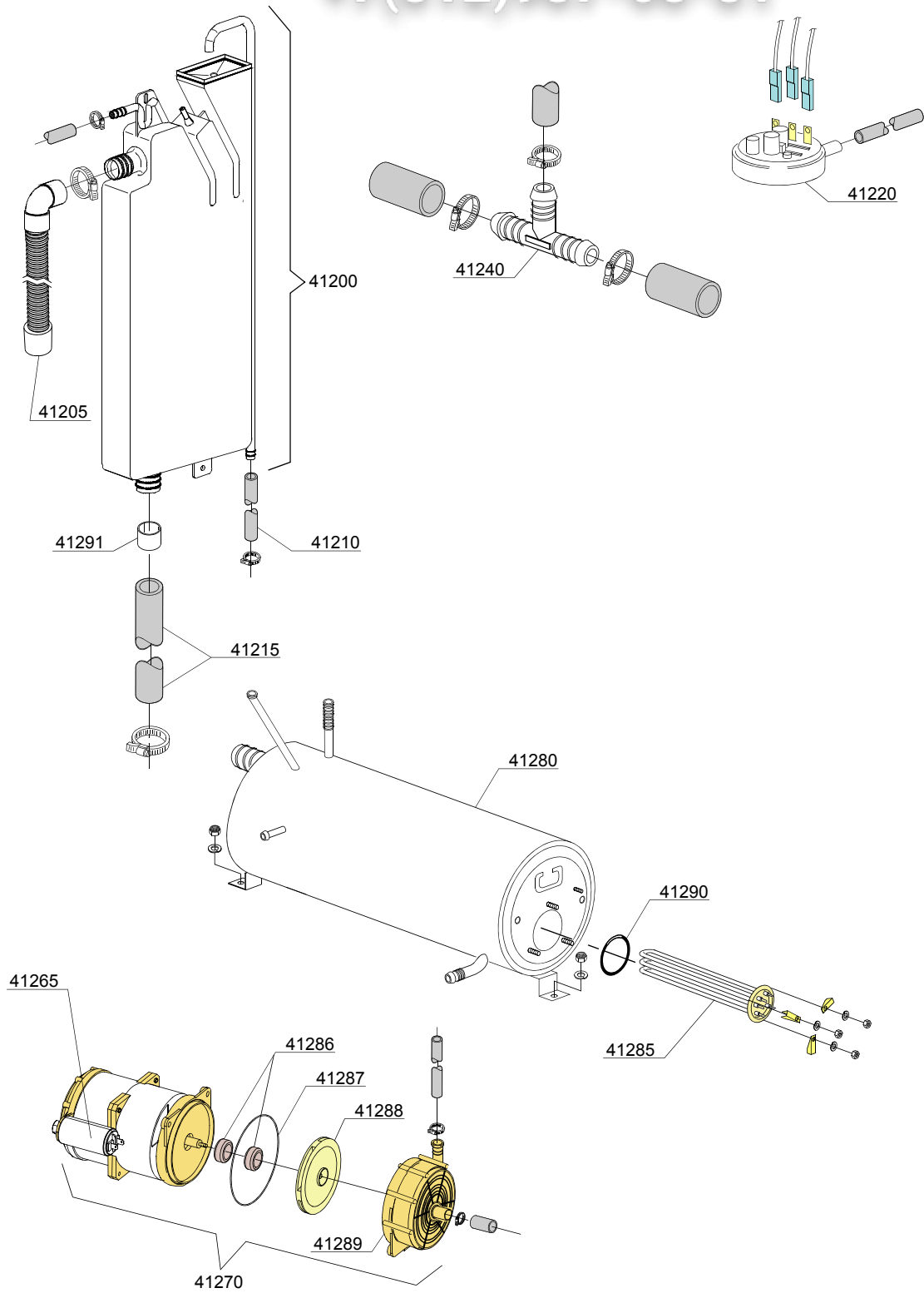

ID	P-code	SN from	SN to	Mod	Acces.	Volt	Description
Module: Rinse with steady temperature							
41200	15720		-	e,i			Break tank assembly
41205	15721		-	e,i			BT long pipe L=1070
41210	2907352		-	e,i			PVC WRAS rubber hose
41215	x		-	e,i			Pipe coupling
41220	10706/A		-	e,i			47-27 pressure switch
41240	540098		-	e,i			3 ways D25
41265	10702		-	e,i			5 uF condenser
41270	15100/DO		-	e,i			Rinsing pump
41275	10718		-	e,i			Pump pipe coupling
41280	560062		-	e,i			Boiler
41285	15089		-	e,i			Boiler Element 4,5KW 230 / 240 VaC 3
41285	15089/B		-	e,i			Boiler Element 4,5KW 240 /440 V
41285	15089/E		-	e,i			Boiler Element 6KW 230 / 240 VaC 3
41286	15100/S		-	e,i			Rotating seals
41287	15100/T		-	e,i			OR (O-ring) gasket EPDM
41288	15100/U		-	e,i			Pump rotor
41289	15100/V		-	e,i			Scroll
41290	13015		-	e,i			OR (O-ring) 6225 gasket 160 NBR
41291	12533		-	e,i			Reinforce for pipe in exit (break tank)

e=ELECTRONICAL SWITCHES, uw=LOWER AND UPPER WASHING, i=INSULATED MODEL

20S5=20S5

bt=BREAK TANK, bp=BOOSTER PUMP, dvgw=DVGW, ws=WATER SOFTNER, dd=DETERGENT DISPENSER, dp=DRAIN PUMP

A=3/N/PE~380-400V 50-60Hz, D=3/PE~200-210V 50-60Hz, F=2/PE~220-240V 50-60Hz, G=3/N/PE~415V 50-60Hz, H=3/PE~220-230V 50-60Hz, K=3/PE~380-400V 50-60Hz, L=3/PE~415V 50-60Hz, M=3/PE~440V 60Hz, P=1/N/PE~220-230V 50-60Hz, R=2/PE~220-240V 50-60Hz, U=1/N/PE~240V 50-60Hz, V=3/PE~240V 50-60Hz, W=1/N/PE~100-110V 50-60Hz

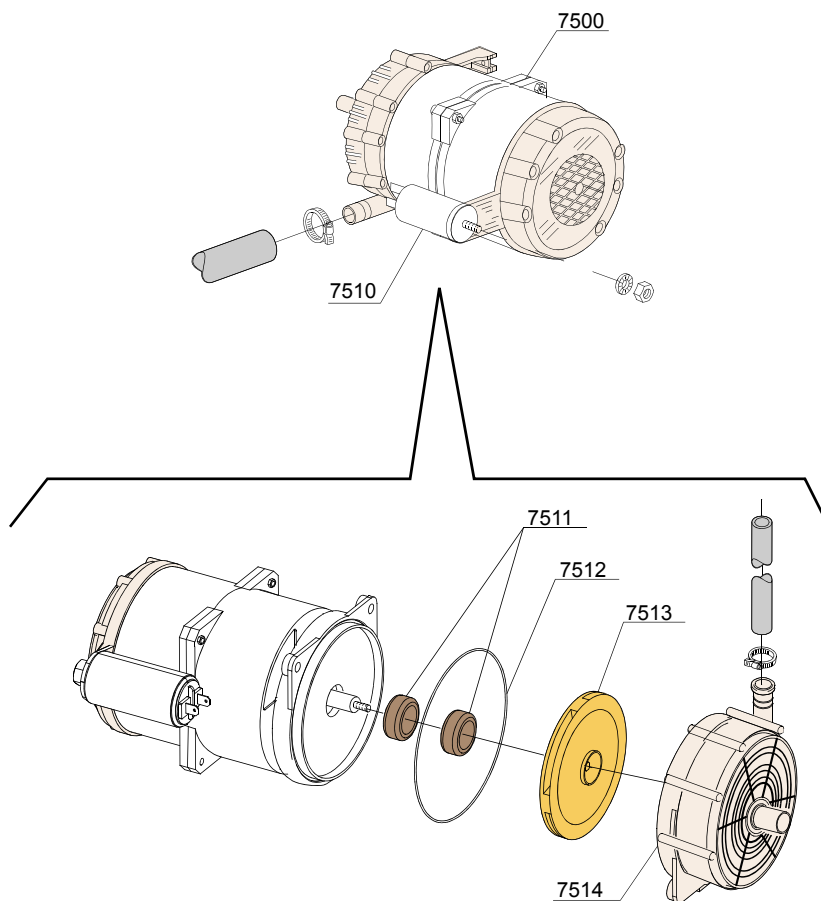

VERSIONE PLUS
SYSTEM PLUS VERSION
VERSION SYSTEME PLUS

vsezip.ru

ID	P-code	SN from	SN to	Mod	Acces	Volt	Description
Module:Booster pump							
7500	15100/DO		-	e,i	bp		Booster pump 220/240V - body pumps in plastic
7510	10702		-	e,i	bp		5 uF condenser - 450V
7511	15100/S			e,i	bp		Rotating seals
7512	15100/T			e,i	bp		OR (O-ring) gasket EPDM
7513	15100/U			e,i	bp		Pump rotor
7514	15100/V			e,i	bp		Scroll

e=ELECTRONICAL SWITCHES, uw=LOWER AND UPPER WASHING, i=INSULATED MODEL

20S5=20S5

bt=BREAK TANK, bp=BOOSTER PUMP, dvgw=DVGW, ws=WATER SOFTNER, dd=DETERGENT DISPENSER, dp=DRAIN PUMP

A=3/N/PE~380-400V 50-60Hz, D=3/PE~200-210V 50-60Hz, F=2/PE~220-240V 50-60Hz, G=3/N/PE~415V 50-60Hz, H=3/PE~220-230V 50-60Hz, K=3/PE~380-400V 50-60Hz, L=3/PE~415V 50-60Hz, M=3/PE~440V 60Hz, P=1/N/PE~220-230V 50-60Hz, R=2/PE~220-240V 50-60Hz, U=1/N/PE~240V 50-60Hz, V=3/PE~240V 50-60Hz, W=1/N/PE~100-110V 50-60Hz

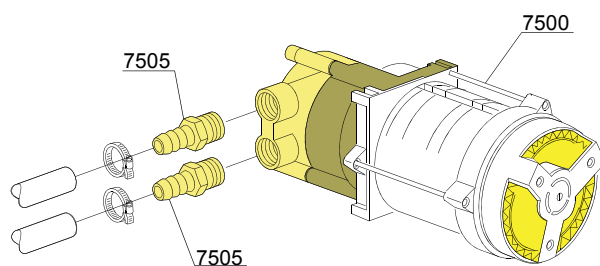

VERSIONE STANDARD / VERSIONE POMPA AUM. PRESSIONE
STANDARD VERSION / BOOSTER PUMP VERSION
VERSION STANDARD / VERSION POMPE AUGMENT. PRESSION

vsezip.ru

ID	P-code	SN from	SN to	Mod	Acces	Volt	Description
Module:Booster pump							
7500	15100/D		-	e,i	bp		Booster pump 220/240V - body pumps in plastic
7505	10221311		-	e,i	bp		Rubber holder Ø 12 3/8G

e=ELECTRONICAL SWITCHES, uw=LOWER AND UPPER WASHING, i=INSULATED MODEL

20S5=20S5

bt=BREAK TANK, bp=BOOSTER PUMP, dvgw=DVGW, ws=WATER SOFTNER, dd=DETERGENT DISPENSER, dp=DRAIN PUMP

A=3/N/PE~380-400V 50-60Hz, D=3/PE~200-210V 50-60Hz, F=2/PE~220-240V 50-60Hz, G=3/N/PE~415V 50-60Hz, H=3/PE~220-230V 50-60Hz, K=3/PE~380-400V 50-60Hz, L=3/PE~415V 50-60Hz, M=3/PE~440V 60Hz, P=1/N/PE~220-230V 50-60Hz, R=2/PE~220-240V 50-60Hz, U=1/N/PE~240V 50-60Hz, V=3/PE~240V 50-60Hz, W=1/N/PE~100-110V 50-60Hz

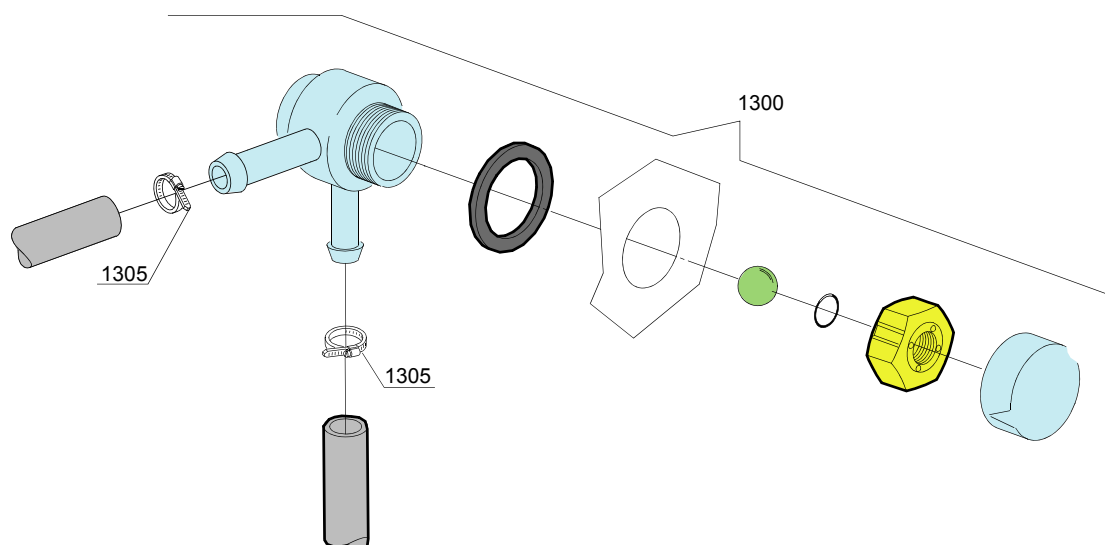

vsezip.ru

ID	P-code	SN from	SN to	Mod	Acces	Volt	Description
Module: DVGW							
1300	99900006		-	e,i	dvgw		DVGW assembly
1305	11807		-	e,i	dvgw		12/22 clamp (minimum 3 pieces)

e=ELECTRONICAL SWITCHES, uw=LOWER AND UPPER WASHING, i=INSULATED MODEL

20S5=20S5

bt=BREAK TANK, bp=BOOSTER PUMP, dvgw=DVGW, ws=WATER SOFTNER, dd=DETERGENT DISPENSER, dp=DRAIN PUMP

A=3/N/PE~380-400V 50-60Hz, D=3/PE~200-210V 50-60Hz, F=2/PE~220-240V 50-60Hz, G=3/N/PE~415V 50-60Hz, H=3/PE~220-230V 50-60Hz, K=3/PE~380-400V 50-60Hz, L=3/PE~415V 50-60Hz, M=3/PE~440V 60Hz, P=1/N/PE~220-230V 50-60Hz, R=2/PE~220-240V 50-60Hz, U=1/N/PE~240V 50-60Hz, V=3/PE~240V 50-60Hz, W=1/N/PE~100-110V 50-60Hz

09_001_e

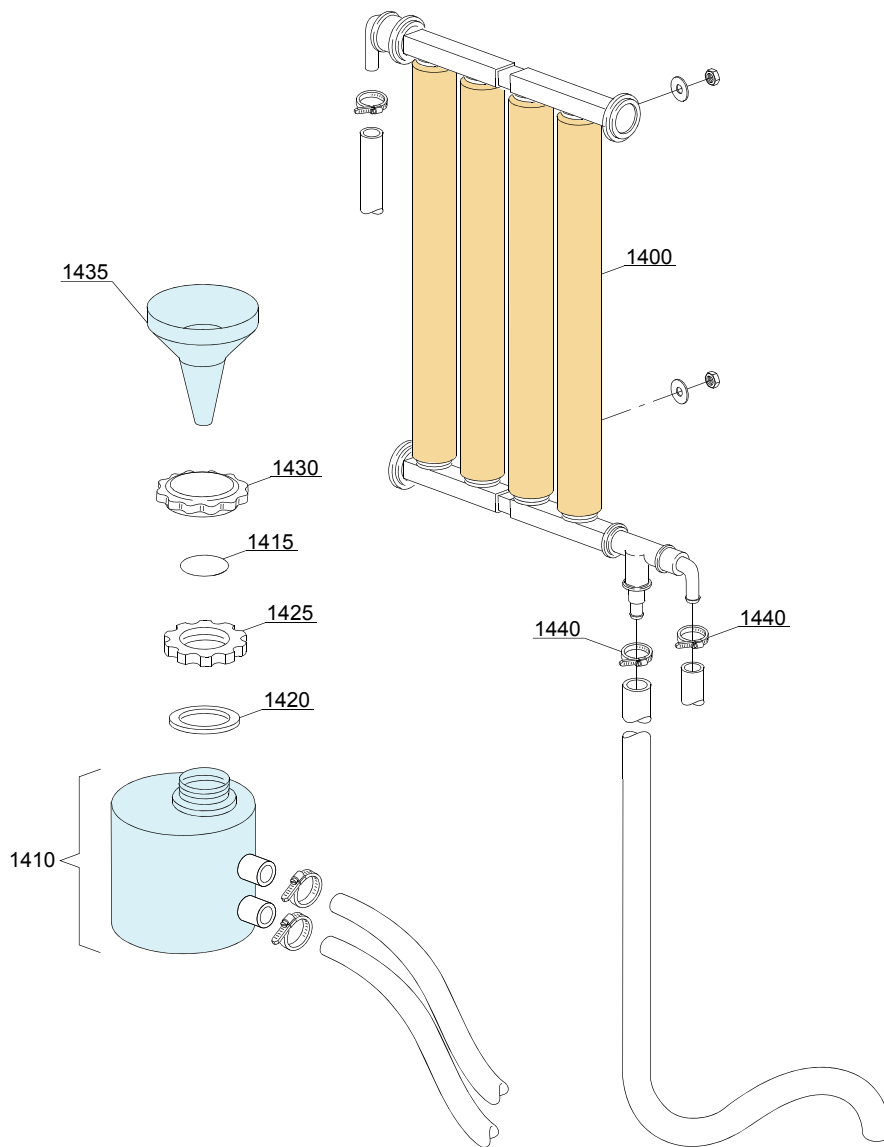

ID	P-code	SN from	SN to	Mod	Acces.	Volt	Description
Module: Water softner group							
1400	16066		-	e	ws		4 elements water softner
1410	16065		-	e	ws		Salt container
1415	16067/A		-	e	ws		OR O-ring
1420	16067/B		-	e	ws		O-ring
1425	16067/C		-	e	ws		Ring nut
1430	16067/D		-	e	ws		Plug
1435	16082		-	e	ws		Funnel
1440	11807		-	e	ws		12/22 clamp (minimum 3 pieces)

e=ELECTRONICAL SWITCHES, uw=LOWER AND UPPER WASHING, i=INSULATED MODEL

20S5=20S5

bt=BREAK TANK, bp=BOOSTER PUMP, dvgw=DVGW, ws=WATER SOFTNER, dd=DETERGENT DISPENSER, dp=DRAIN PUMP

A=3/N/PE~380-400V 50-60Hz, D=3/PE~200-210V 50-60Hz, F=2/PE~220-240V 50-60Hz, G=3/N/PE~415V 50-60Hz, H=3/PE~220-230V 50-60Hz, K=3/PE~380-400V 50-60Hz, L=3/PE~415V 50-60Hz, M=3/PE~440V 60Hz, P=1/N/PE~220-230V 50-60Hz, R=2/PE~220-240V 50-60Hz, U=1/N/PE~240V 50-60Hz, V=3/PE~240V 50-60Hz, W=1/N/PE~100-110V 50-60Hz

vsezip.ru

+7(812)987-08-81

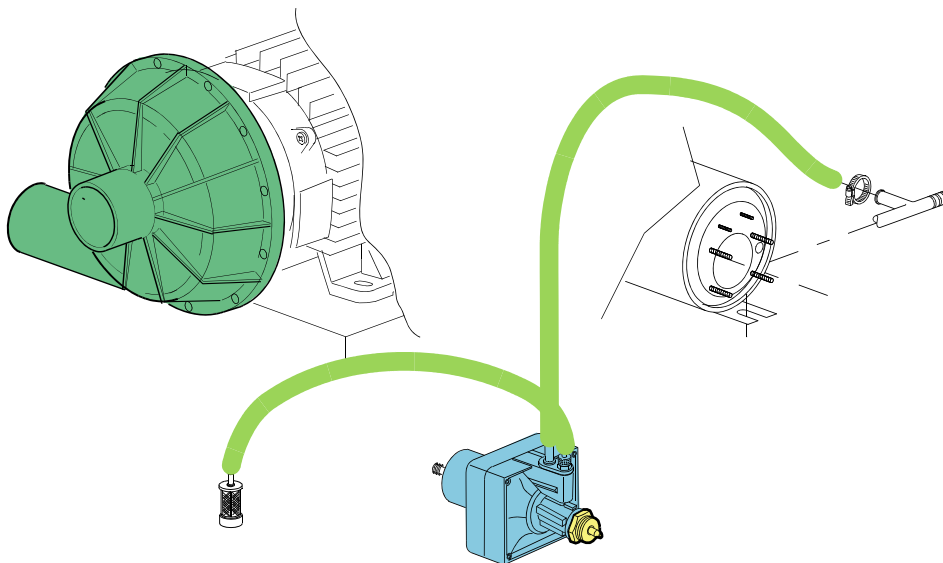
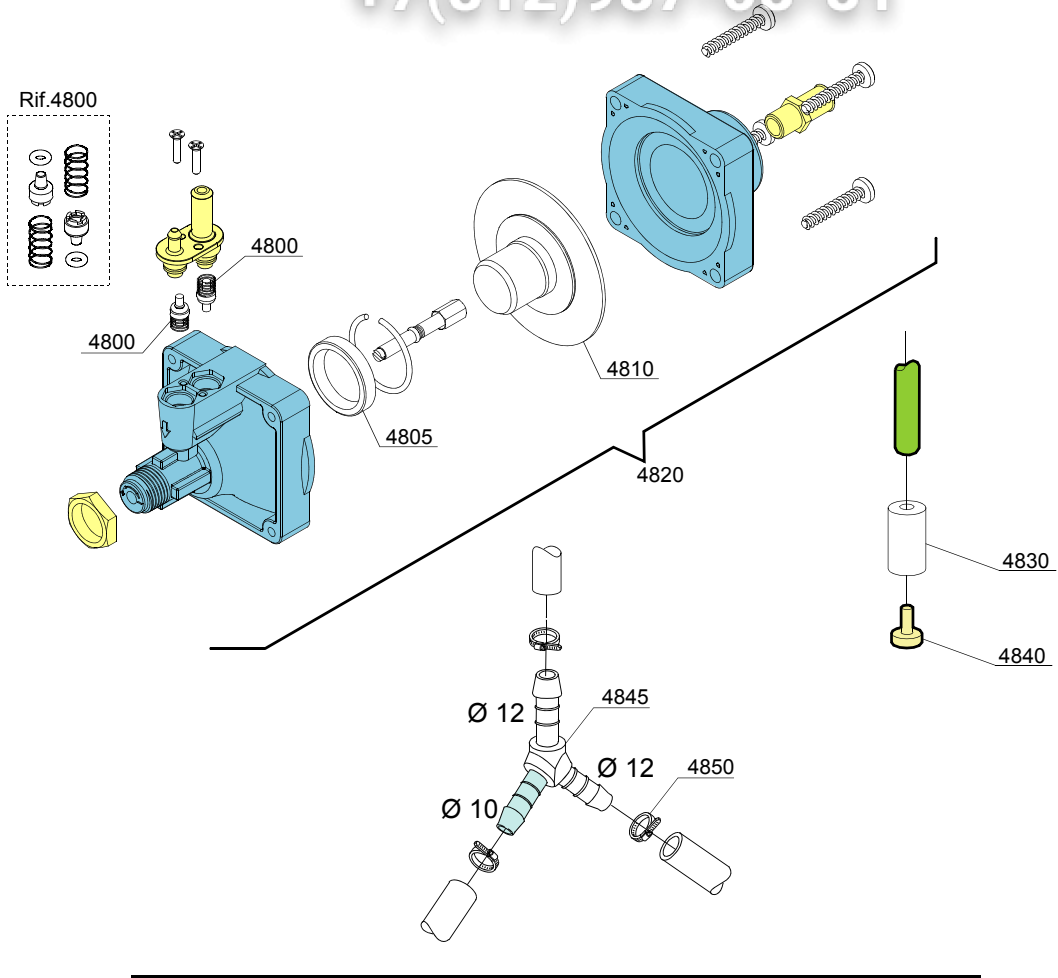

10_004be

vsezip.ru

ID	P-code	SN from	SN to	Mod	Acces	Volt	Description
Module: Rinse aid dispenser group							
4800	10805		-				Tecnopro non return valve
4805	10806		-				Ø22 O-ring
4810	10807		-				Membrane
4820	10599999		-				Rinse aid dispenser
4830	12525		-				Ballast
4840	15058		-				Small filter (minimum 3 pieces)
4845	540105		-				Ø12-10-12 mm plastic 3 ways connection
4850	11807		-				Clamp 12-22 (minimum 3 pieces)

e=ELECTRONICAL SWITCHES, uw=LOWER AND UPPER WASHING, i=INSULATED MODEL

20S5=20S5

bt=BREAK TANK, bp=BOOSTER PUMP, dvgw=DVGW, ws=WATER SOFTNER, dd=DETERGENT DISPENSER, dp=DRAIN PUMP

A=3/N/PE~380-400V 50-60Hz, D=3/PE~200-210V 50-60Hz, F=2/PE~220-240V 50-60Hz, G=3/N/PE~415V 50-60Hz, H=3/PE~220-230V 50-60Hz, K=3/PE~380-400V 50-60Hz, L=3/PE~415V 50-60Hz, M=3/PE~440V 60Hz, P=1/N/PE~220-230V 50-60Hz, R=2/PE~220-240V 50-60Hz, U=1/N/PE~240V 50-60Hz, V=3/PE~240V 50-60Hz, W=1/N/PE~100-110V 50-60Hz

vsezip.ru

+7(812)987-08-81

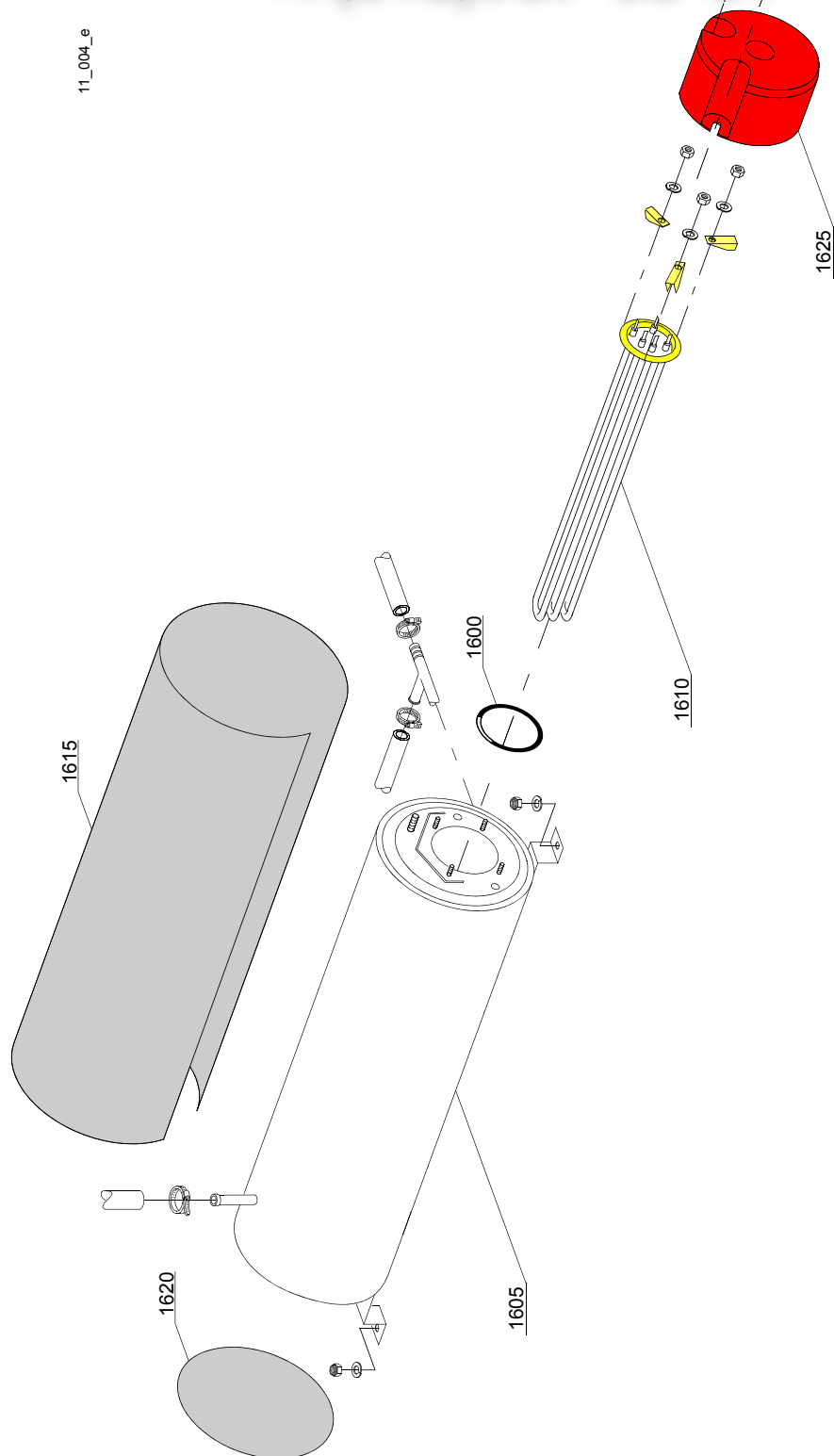

ID	P-code	SN from	SN to	Mod.	Acces.	Volt	Description
Module:Boiler group							
1600	13015		-				6225 OR 160 NBR O-ring (minimum 5 pieces)
1605	22002		-				Boiler
1610	30001010		-				6/6,53KW 230/240V 3 heating element
1615	30002030		-				Insulation boiler
1620	75205		-				Ø160 End piece (minimum 2 pieces)
1625	75311		-				Heating element cover

e=ELECTRONICAL SWITCHES, uw=LOWER AND UPPER WASHING, i=INSULATED MODEL

20S5=20S5

bt=BREAK TANK, bp=BOOSTER PUMP, dvgw=DVGW, ws=WATER SOFTNER, dd=DETERGENT DISPENSER, dp=DRAIN PUMP

A=3/N/PE~380-400V 50-60Hz, D=3/PE~200-210V 50-60Hz, F=2/PE~220-240V 50-60Hz, G=3/N/PE~415V 50-60Hz, H=3/PE~220-230V 50-60Hz, K=3/PE~380-400V 50-60Hz, L=3/PE~415V 50-60Hz, M=3/PE~440V 60Hz, P=1/N/PE~220-230V 50-60Hz, R=2/PE~220-240V 50-60Hz, U=1/N/PE~240V 50-60Hz, V=3/PE~240V 50-60Hz, W=1/N/PE~100-110V 50-60Hz

vsezip.ru

+7(812)987-08-81

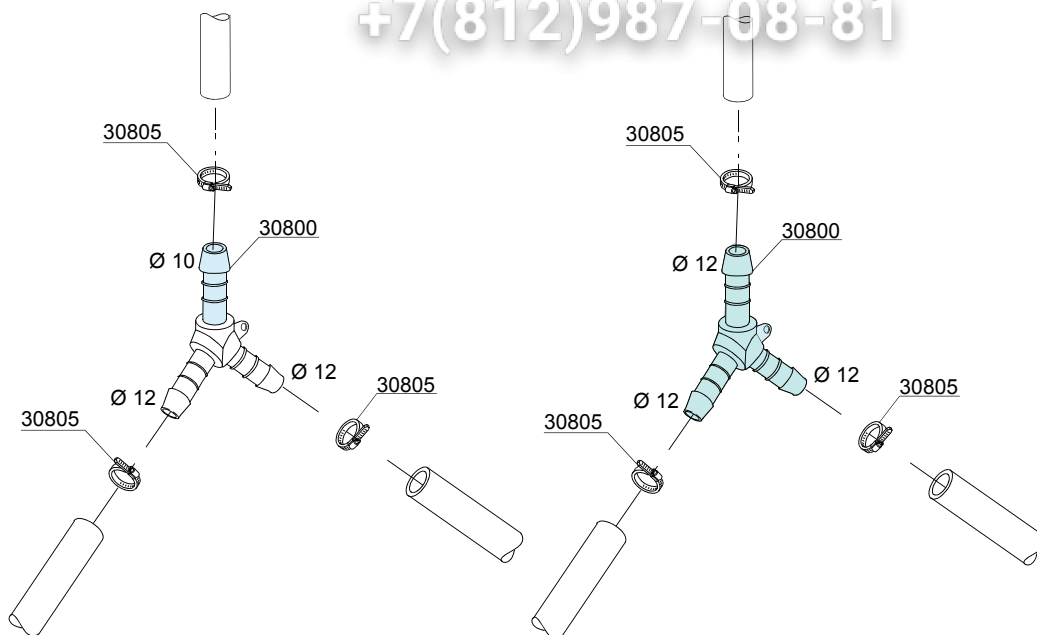

12_003ae

vsezip.ru

ID	P-code	SN from	SN to	Mod	Acces.	Volt	Description
Module:3 ways connection							
30800	540091		-	e,i			Ø12 mm plastic 3 ways connection
30800	540104		-	e,i			Ø10-12-12 mm plastic 3 ways connection
30805	11807		-	e,i			12/22 clamp (minimum 3 pieces)

e=ELECTRONICAL SWITCHES, uw=LOWER AND UPPER WASHING, i=INSULATED MODEL

20S5=20S5

bt=BREAK TANK, bp=BOOSTER PUMP, dvgw=DVGW, ws=WATER SOFTNER, dd=DETERGENT DISPENSER, dp=DRAIN PUMP

A=3/N/PE~380-400V 50-60Hz, D=3/PE~200-210V 50-60Hz, F=2/PE~220-240V 50-60Hz, G=3/N/PE~415V 50-60Hz, H=3/PE~220-230V 50-60Hz, K=3/PE~380-400V 50-60Hz, L=3/PE~415V 50-60Hz, M=3/PE~440V 60Hz, P=1/N/PE~220-230V 50-60Hz, R=2/PE~220-240V 50-60Hz, U=1/N/PE~240V 50-60Hz, V=3/PE~240V 50-60Hz, W=1/N/PE~100-110V 50-60Hz

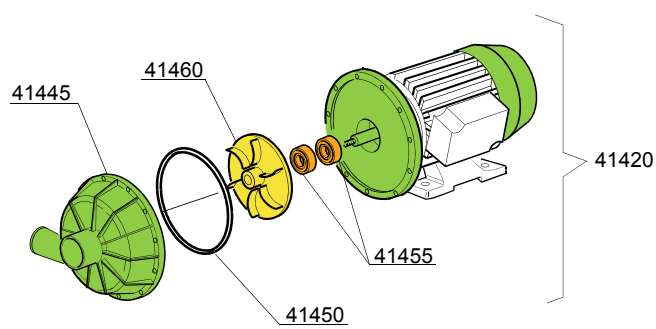
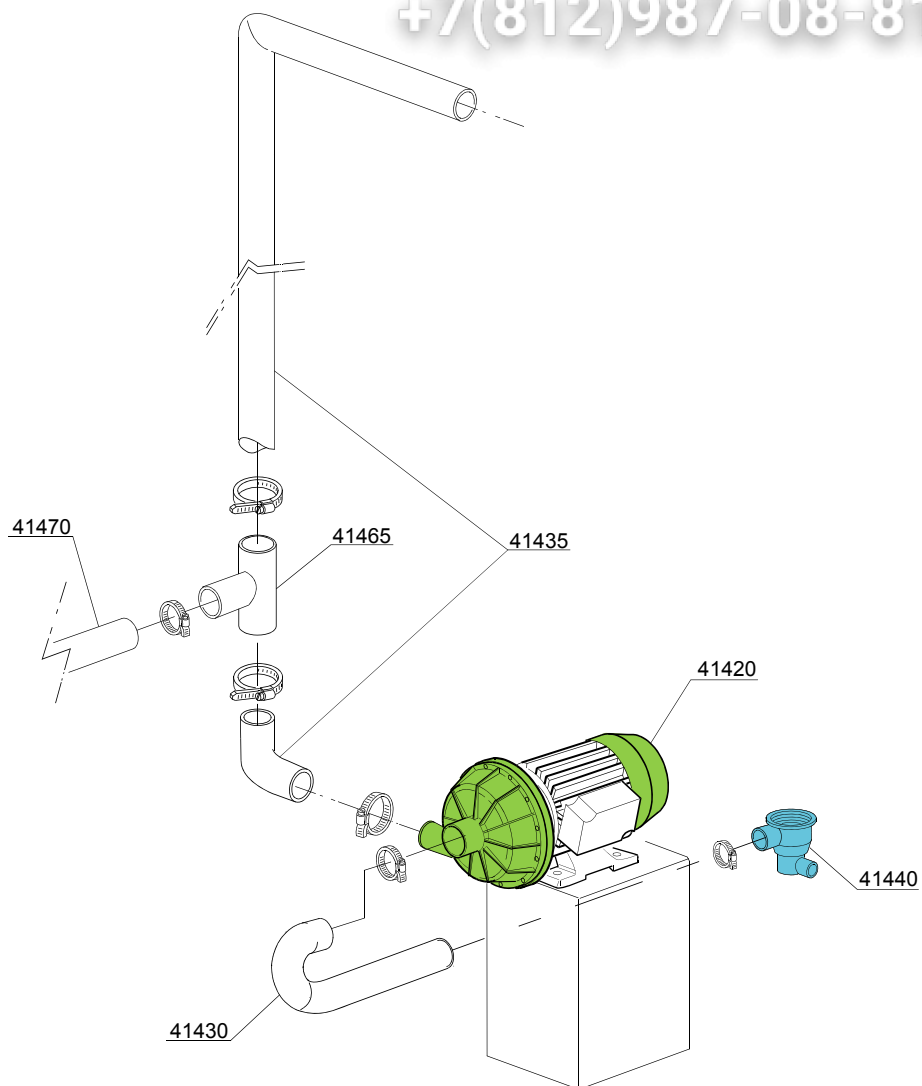

ID	P-code	SN from	SN to	Mod.	Acces.	Volt	Description
Module: Wash pump							
41420	10300057/A		-	e,uw		A	1,5 Hp wash pump 230 / 380 V
41430	550229		-	e,uw			Pump pipe coupling
41435	550228		-	e,uw			Top delivery pipe
41440	500603		-	e,uw			Scrap tray
41445	10200222		-	e,uw			Scroll
41450	10200290		-	e,uw			O-ring
41455	15080		-	e,uw			Rotating seals
41460	10209807		-	e,uw			Pump rotor
41465	550230		-	e,uw			"T"Pipe coupling
41470	15033/A		-	e,uw			Tube envoyée lavage inférieur

e=ELECTRONICAL SWITCHES, uw=LOWER AND UPPER WASHING, i=INSULATED MODEL

20S5=20S5

bt=BREAK TANK, bp=BOOSTER PUMP, dvgw=DVGW, ws=WATER SOFTNER, dd=DETERGENT DISPENSER, dp=DRAIN PUMP

A=3/N/PE~380-400V 50-60Hz, D=3/PE~200-210V 50-60Hz, F=2/PE~220-240V 50-60Hz, G=3/N/PE~415V 50-60Hz, H=3/PE~220-230V 50-60Hz, K=3/PE~380-400V 50-60Hz, L=3/PE~415V 50-60Hz, M=3/PE~440V 60Hz, P=1/N/PE~220-230V 50-60Hz, R=2/PE~220-240V 50-60Hz, U=1/N/PE~240V 50-60Hz, V=3/PE~240V 50-60Hz, W=1/N/PE~100-110V 50-60Hz

vsezip.ru

+7(812)987-08-81

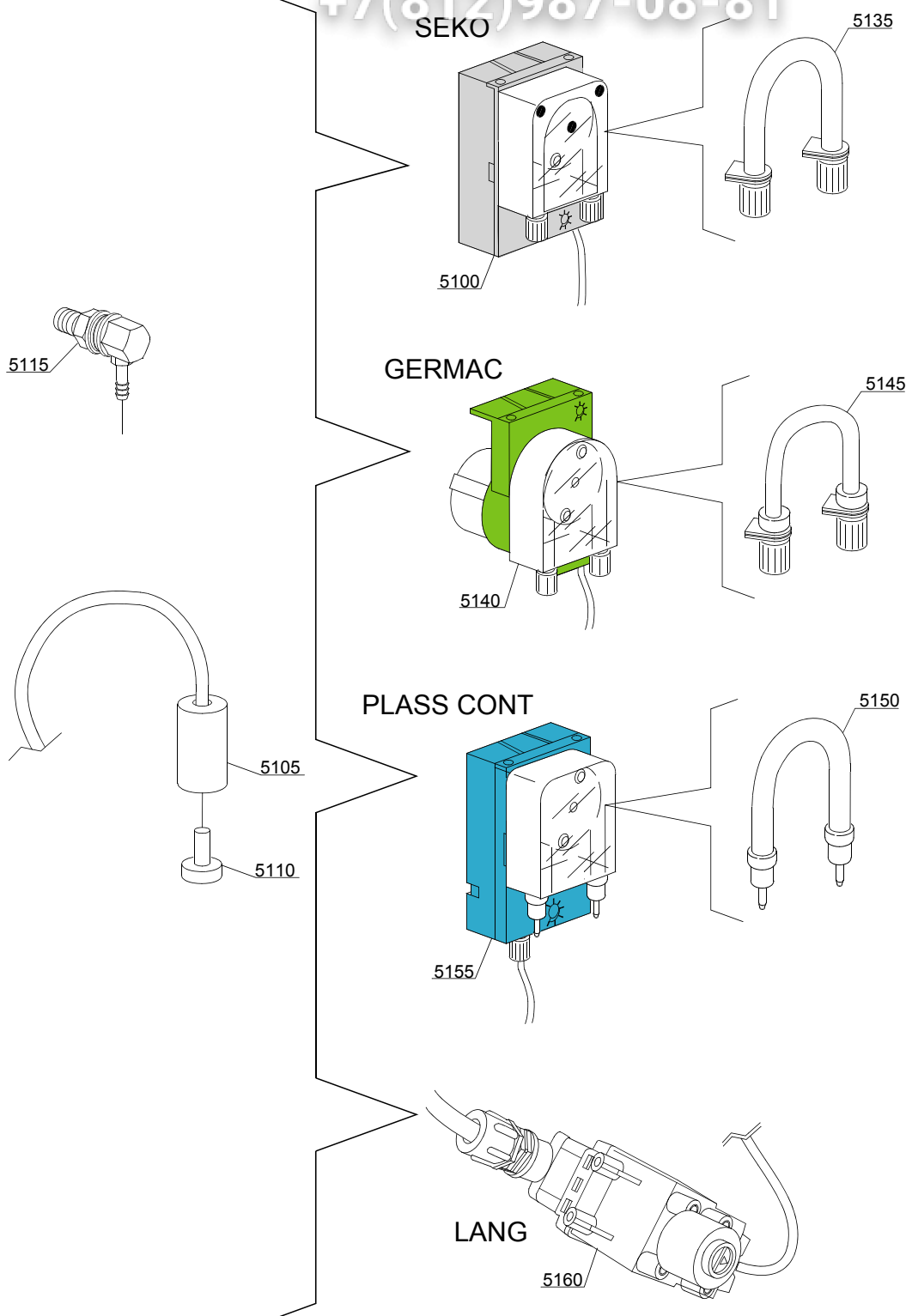

14_004_e

ID	P-code	SN from	SN to	Mod	Acces.	Volt	Description
Module:Dosing detergent group							
5100	15985		-	i,e	dd		Seko detergent pump
5105	12525		-	i,e	dd		Ballast
5110	15058		-	i,e	dd		Small filter (minimum 3 pieces)
5115	15123		-	i,e	dd		Complet stainless steel injector
5135	15185		-	i,e	dd		Seko thermoplastic pipe
5140	15985		-	i,e	dd		Germac detergent pump
5145	15108/E		-	i,e	dd		Germac thermoplastic pipe
5150	15985/A			i,e	dd		Plas Cont thermoplastic pipe
5155	15985			i,e	dd		Plas Cont detergent pump
5160	15108/L			i,e	dd		LANG detergent pump

e=ELECTRONICAL SWITCHES, uw=LOWER AND UPPER WASHING, i=INSULATED MODEL

20S5=20S5

bt=BREAK TANK, bp=BOOSTER PUMP, dvgw=DVGW, ws=WATER SOFTNER, dd=DETERGENT DISPENSER, dp=DRAIN PUMP

A=3/N/PE~380-400V 50-60Hz, D=3/PE~200-210V 50-60Hz, F=2/PE~220-240V 50-60Hz, G=3/N/PE~415V 50-60Hz, H=3/PE~220-230V 50-60Hz, K=3/PE~380-400V 50-60Hz, L=3/PE~415V 50-60Hz, M=3/PE~440V 60Hz, P=1/N/PE~220-230V 50-60Hz, R=2/PE~220-240V 50-60Hz, U=1/N/PE~240V 50-60Hz, V=3/PE~240V 50-60Hz, W=1/N/PE~100-110V 50-60Hz

15_003_e

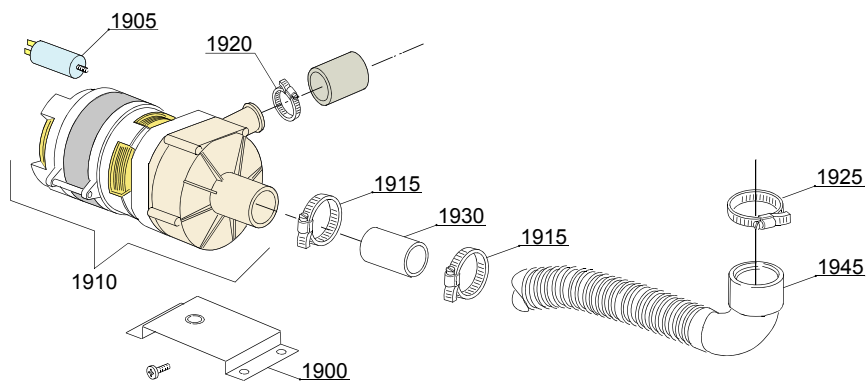

ID	P-code	SN from	SN to	Mod	Acces.	Volt	Description
Module: Drain pump group							
1900	440122		-		dp		Pump support
1905	10702		-		dp		5 uF condenser - 450V
1910	10501/A		-		dp		190W 230V drain pump
1915	11806		-		dp		25/40 clamp (minimum 2 pieces)
1920	11836		-		dp		20/32 clamp (minimum 3 pieces)
1925	11809		-		dp		30/45 clamp (minimum 2 pieces)
1930	18044		-		dp		Ø28 top wash pipe
1945	18767		-		dp		Drain coude/pump connection pipe

e=ELECTRONICAL SWITCHES, uw=LOWER AND UPPER WASHING, i=INSULATED MODEL

20S5=20S5

bt=BREAK TANK, bp=BOOSTER PUMP, dvgw=DVGW, ws=WATER SOFTNER, dd=DETERGENT DISPENSER, dp=DRAIN PUMP

A=3/N/PE~380-400V 50-60Hz, D=3/PE~200-210V 50-60Hz, F=2/PE~220-240V 50-60Hz, G=3/N/PE~415V 50-60Hz, H=3/PE~220-230V 50-60Hz, K=3/PE~380-400V 50-60Hz, L=3/PE~415V 50-60Hz, M=3/PE~440V 60Hz, P=1/N/PE~220-230V 50-60Hz, R=2/PE~220-240V 50-60Hz, U=1/N/PE~240V 50-60Hz, V=3/PE~240V 50-60Hz, W=1/N/PE~100-110V 50-60Hz

vsezip.ru

+7(812)987-08-81

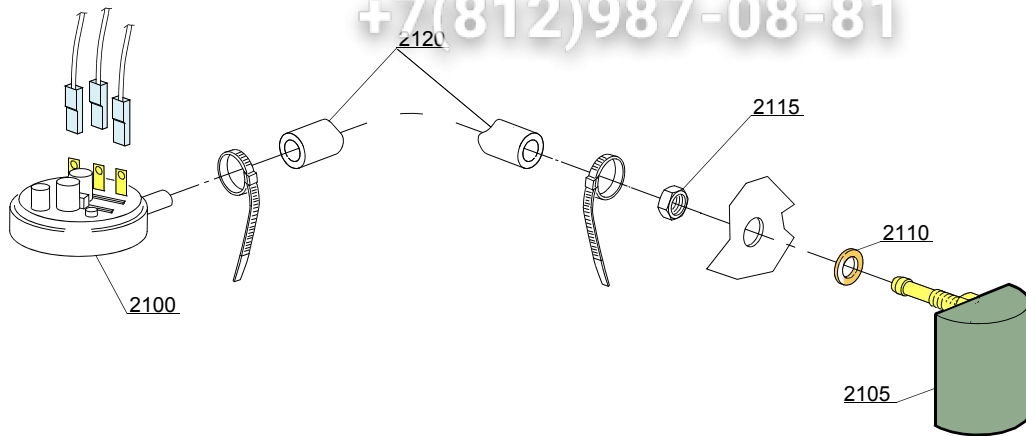

16_001_e

ID	P-code	SN from	SN to	Mod	Acces.	Volt	Description
Module: Pressure switch group with air trap							
2100	10300026		-	i,e			76-38 pressure switch
2105	135911/C	4020618	-	i,e			Grey air trap assembly
2110	13301		-	i,e			O-ring (minimum 10 pieces) - D14x8x1,5
2115	11702		-	i,e			M8 stainless steel nut (minimum 10 pieces)
2120	14508		-	i,e			4,5X9 EPDM rubber hose (minimum 2mt)

e=ELECTRONICAL SWITCHES, uw=LOWER AND UPPER WASHING, i=INSULATED MODEL

20S5=20S5

bt=BREAK TANK, bp=BOOSTER PUMP, dvgw=DVGW, ws=WATER SOFTNER, dd=DETERGENT DISPENSER, dp=DRAIN PUMP

A=3/N/PE~380-400V 50-60Hz, D=3/PE~200-210V 50-60Hz, F=2/PE~220-240V 50-60Hz, G=3/N/PE~415V 50-60Hz, H=3/PE~220-230V 50-60Hz, K=3/PE~380-400V 50-60Hz, L=3/PE~415V 50-60Hz, M=3/PE~440V 60Hz, P=1/N/PE~220-230V 50-60Hz, R=2/PE~220-240V 50-60Hz, U=1/N/PE~240V 50-60Hz, V=3/PE~240V 50-60Hz, W=1/N/PE~100-110V 50-60Hz

vsezip.ru

+7(812)987-08-81

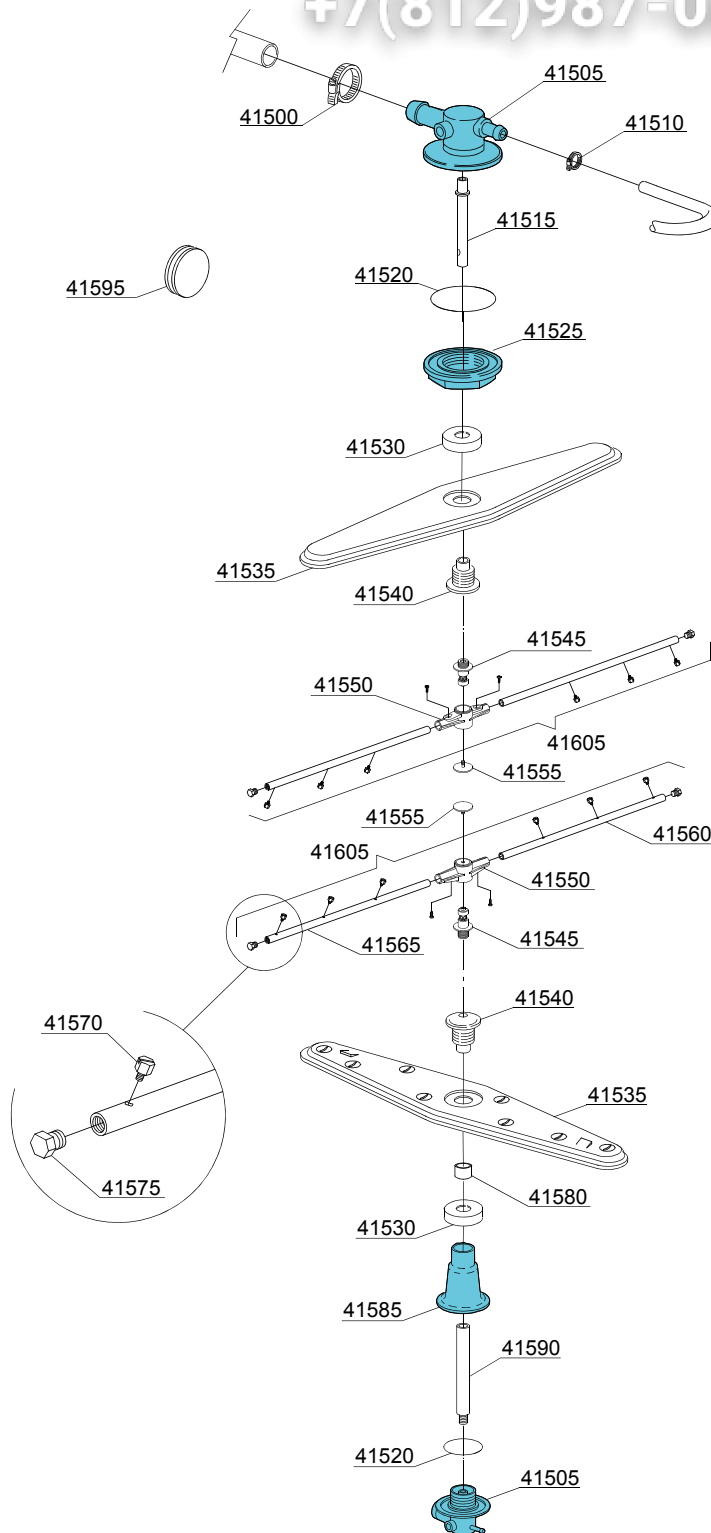

17_127_e

ID	P-code	SN from	SN to	Mod	Acces.	Volt	Description
Module: Turret group with rotating arms							
41500	11806		-	uw,e			25/40 clamp (minimum 2 pieces)
41505	500612		-	uw,e			Top/lower turret
41510	11807		-	uw,e			12/22 clamp (minimum 3 pieces)
41515	75315		-	uw,e			Rinse axle extension
41515	500703		-	uw,e			Upper rinse axle extension
41520	13015		-	uw,e			6225 OR 160 NBR O-ring (minimum 5 pieces)
41525	500623		-	uw,e			Ring nut for fixing turret
41530	75317		-	uw,e			Nut for wash arm bearing
41535	75915		-	uw,e			Stainless steel wash rotor
41540	75316		-	uw,e			Hub for rotor
41545	10651		-	uw,e			Rinse axle
41550	10650		-	uw,e			Rinse arm
41555	10652		-	uw,e			Rinse arm screw
41560	10657		-	uw,e			Right rinse arm - stainless steel nozzle
41565	10658		-	uw,e			Left rinse arm - stainless steel nozzle
41570	560018		-	uw,e			Stainless steel rinse nozzle
41575	560017		-	uw,e			Rinse arm plug
41580	550220		-	uw,e			Hub rotor/pipe coupling spacer
41585	550225		-	uw,e			Lower pipe coupling
41590	500704		-	uw,e			Rinse lower distributor connection axle
41595	13316/A		-	uw,e			DVGW hole O-ring
41605	75918		-	uw,e			Top/lower rinse arm complete

e=ELECTRONICAL SWITCHES, uw=LOWER AND UPPER WASHING, i=INSULATED MODEL

20S5=20S5

bt=BREAK TANK, bp=BOOSTER PUMP, dvgw=DVGW, ws=WATER SOFTNER, dd=DETERGENT DISPENSER, dp=DRAIN PUMP

A=3/N/PE~380-400V 50-60Hz, D=3/PE~200-210V 50-60Hz, F=2/PE~220-240V 50-60Hz, G=3/N/PE~415V 50-60Hz, H=3/PE~220-230V 50-60Hz, K=3/PE~380-400V 50-60Hz, L=3/PE~415V 50-60Hz, M=3/PE~440V 60Hz, P=1/N/PE~220-230V 50-60Hz, R=2/PE~220-240V 50-60Hz, U=1/N/PE~240V 50-60Hz, V=3/PE~240V 50-60Hz, W=1/N/PE~100-110V 50-60Hz

vsezip.ru

+7(812)987-08-81

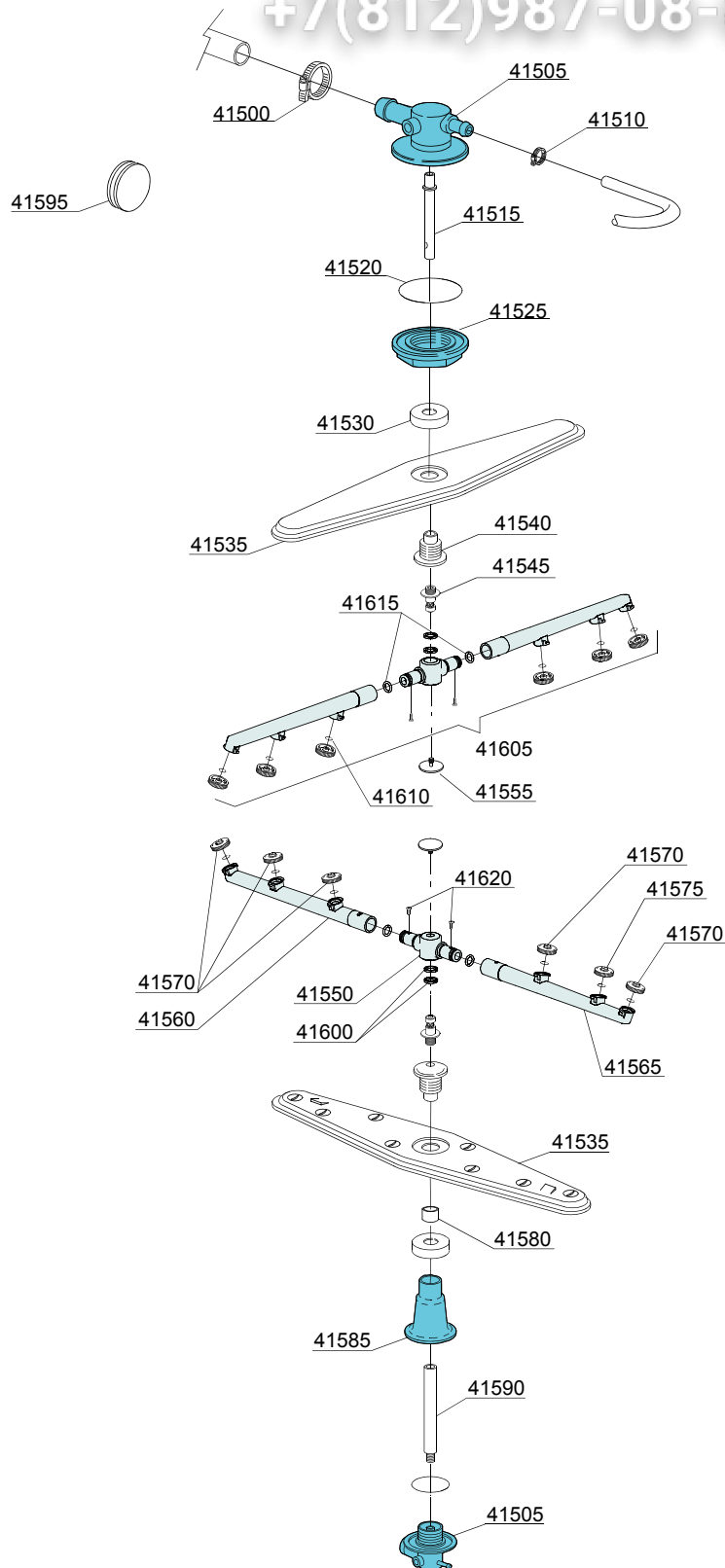

17_127be

ID	P-code	SN from	SN to	Mod	Acces.	Volt	Description
Module: Turret group with rotating arms							
41500	11806		-	uw,e			25/40 clamp (minimum 2 pieces)
41505	500612		-	uw,e			Top/lower turret
41510	11807		-	uw,e			12/22 clamp (minimum 3 pieces)
41515	500703		-	uw,e			Upper rinse axle extension
41520	13015		-	uw,e			6225 OR 160 NBR O-ring (minimum 5 pieces)
41525	500623		-	uw,e			Ring nut for fixing turret
41530	75317		-	uw,e			Nut for wash arm bearing
41535	75915		-	uw,e			Stainless steel wash rotor
41540	75316		-	uw,e			Hub for rotor
41545	10651		-	uw,e			Rinse axle
41550	75920/A		-	uw,e			Rinse arm
41555	10652		-	uw,e			Rinse arm screw
41560	75920/D		-	uw,e			Right rinse arm - stainless steel nozzle
41565	75920/S		-	uw,e			Left rinse arm - stainless steel nozzle
41570	10371		-	uw,e			Open rinse nozzle
41575	10372		-	uw,e			Closed rinse nozzle
41580	550220		-	uw,e			Hub rotor/pipe coupling spacer
41585	550225		-	uw,e			Lower pipe coupling
41590	500704		-	uw,e			Rinse lower distributor connection axle
41595	13316/A		-	uw,e			DVGW hole O-ring
41600	75920/B		-	uw,e			O ring for hub (rinse arm)
41605	75920		-	uw,e			Top/lower rinse arm complete
41610	13002		-	uw,e			OR R6 NBR O-ring (minimum 10 pieces)
41615	13002		-	uw,e			OR R6 NBR O-ring (minimum 10 pieces)
41620	11004		-	uw,e			4x10 TCB Ø8 spax toothed screw

e=ELECTRONICAL SWITCHES, uw=LOWER AND UPPER WASHING, i=INSULATED MODEL

20S5=20S5

bt=BREAK TANK, bp=BOOSTER PUMP, dvgw=DVGW, ws=WATER SOFTNER, dd=DETERGENT DISPENSER, dp=DRAIN PUMP

A=3/N/PE~380-400V 50-60Hz, D=3/PE~200-210V 50-60Hz, F=2/PE~220-240V 50-60Hz, G=3/N/PE~415V 50-60Hz, H=3/PE~220-230V 50-60Hz, K=3/PE~380-400V 50-60Hz, L=3/PE~415V 50-60Hz, M=3/PE~440V 60Hz, P=1/N/PE~220-230V 50-60Hz, R=2/PE~220-240V 50-60Hz, U=1/N/PE~240V 50-60Hz, V=3/PE~240V 50-60Hz, W=1/N/PE~100-110V 50-60Hz