

Зип Общепит

vsezip.ru

+7(812)987-08-81



FX150NN

Edition 20021118-

Зип Общепит
vsezip.ru
+7(812)987-08-81

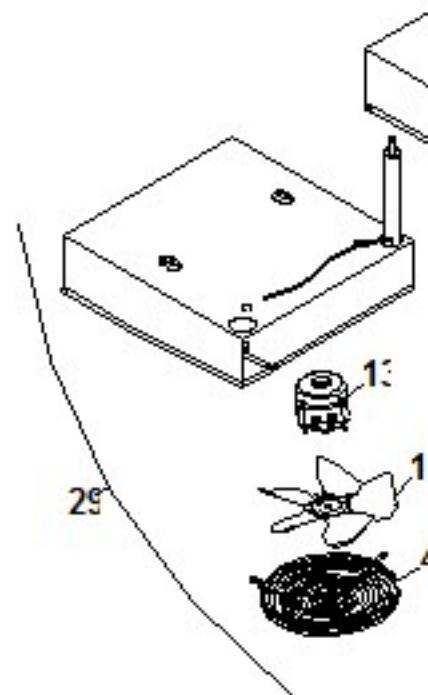

Pos	Code	Description	Info
001	3178300	PLUG	15/06/2002-
002	3601350	RACK SUPPORT	15/06/2002-
003	3601360	RACK SUPPORT	15/06/2002-
004	6012240	DOOR UNIT	15/06/2002-
005	30A4810	JOGGING PANEL	15/06/2002-
006	30F0750	FRIDGE DOOR	15/06/2002-
007	30T4510	BOTTOM BRACKET	15/06/2002-
008	32A2200	POWER SUPPLY CABLE	15/06/2002-
009	32D0020	CABLE CLAMP Ø 4 - 12	15/06/2002-
010	32D0740	TERMINAL BOARD	15/06/2002-
011	32M1550	FAN	15/06/2002-
012	32M2510	FAN	15/06/2002-
013	32M6870	FAN MOTOR	15/06/2002-
014	32V6000	PROBE NTC	15/06/2002-
015	32V1500	CONDENSER	15/06/2002-
016	32V3900	RELAY	15/06/2002-
017	32V3910	ENGINE CUTOUT	15/06/2002-
018	32V6050	THERMOREGULATOR	15/06/2002-
019	32W3770	MICROSWITCH	15/06/2002-
020	32W3790	LIGHT	15/06/2002-
021	32W3800	LAMP-HOLDER	15/06/2002-
022	32W3970	BIPOLAR SWITCH	15/06/2002-
023	32X0120	GROMMET Ø 21	15/06/2002-
024	32X0140	GROMMET Ø13,5-Ø25	15/06/2002-
025	33A0180	FILTER	15/06/2002-
026	33A1200	AUXIL.VALVE	15/06/2002-
027	34D6140	COMPRESSOR R404A (BT)	15/06/2002-
028	34D6180	CONDEN.+BAFFLE	15/06/2002-
029	34D9340	EVAPORATOR	15/06/2002-
030	34D9430	MOTOR UNIT	15/06/2002-
031	35E7050	CONTROL BOARD	15/06/2002-
032	35H1820	COMPONENT GUARD	11/10/2002-
033	35R9121	RACK	15/06/2002-
034	35R9131	RACK	15/06/2002-
035	35R9140	GUIDE	15/06/2002-
036	35R9260	LOCK SUPPORT	15/06/2002-
037	35R9320	SUPPORT	15/06/2002-
038	35R9451	EVAPORATOR GUARD	15/06/2002-
039	35U4230	LOCK SUPPORT	15/06/2002-
040	35V1710	TRAY TRIM	15/06/2002-
041	35W0462	TRAY ASS.Y	15/06/2002-
042	35X5271	PIPE COIL	15/06/2002-
043	35Y3090	LAMP GUARD	15/06/2002-
044	36A0710	GRID	15/06/2002-
045	36C2031	FAN GUARD	15/06/2002-
046	36C5540	FOOT	18/11/2002-
047	36C4790	FAN.PROT.	15/06/2002-
048	36E2110	FRAME TRIM	15/06/2002-
049	36E2120	TOP BRACKET	15/06/2002-
050	36E2240	LAMP PROTECTION GLASS SLIDE	15/06/2002-
051	36E2270	CONDENS. DRAIN	15/06/2002-

Pos	Code	Description	Info
052	36E2280	FRAME TRIM	15/06/2002-
053	36E2300	FRAME TRIM	15/06/2002-
054	36E3870	CONDENS. DRAIN	15/06/2002-
055	36G6520	HINGE	15/06/2002-
056	36M7070	KEY LOCK	15/06/2002-
057	36M7080	HINGE	15/06/2002-
058	36Z1410	GASKET	15/06/2002-
059	36Z1530	COND. TRAY	15/06/2002-
060	37N3610	SILK-SCREE.PANEL	15/06/2002-
061	37Q4370	DOOR GASKET	15/06/2002-
062	40K0565	BODY	15/06/2002-