

SECTION CONTENTS

+7(812)987-08-81

| | |
|--|-----|
| Technical Data..... | 204 |
| Parts Information | 205 |
| Door Assembly..... | 205 |
| Recessed Door Assembly..... | 206 |
| Directional Panel Assembly..... | 207 |
| Pressure Box Assembly | 208 |
| Wiring and Ladder Diagrams | 209 |
| 208-240V 3PH 50/60 Hz Wiring | 209 |
| 208-240V 3PH 50/60 Hz Ladder..... | 210 |
| 440-480V 3PH 50/60 Hz Wiring | 211 |
| 440-480V 3PH 50/60 Hz Ladder..... | 212 |
| 380-415V 3PH 50 Hz Wiring | 213 |
| 380-415V 3PH 50 Hz Ladder | 214 |
| 208-240V 1PH 50/60 Hz Wiring | 215 |
| 208-240V 1PH 50/60 Hz Ladder..... | 216 |
| Return to Main Table of Contents | 3 |

TECHNICAL DATA

+7(812)987-08-81



7 • 14 Esi SPECIFICATIONS

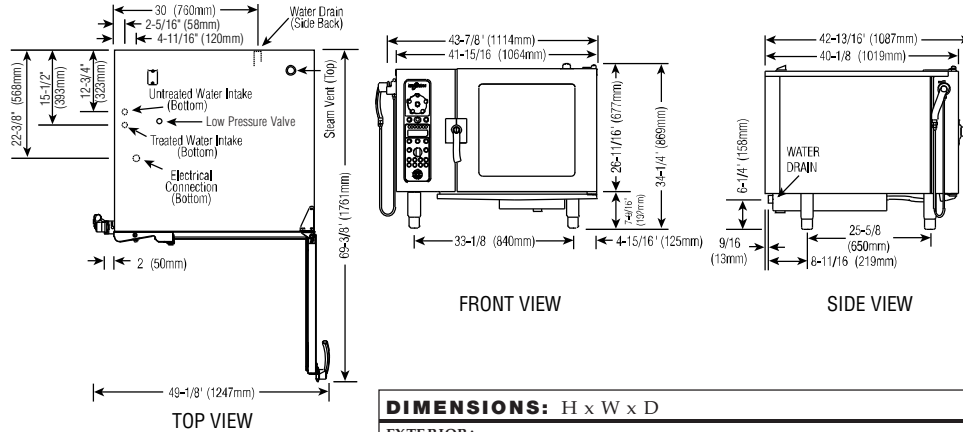

| INSTALLATION REQUIREMENTS | | DIMENSIONS: H x W x D | | | | | |
|---|------------------------|--|------------------------------|--|-------------|---------|------|
| Oven must be installed level. Hood installation is required. Water supply shut-off valve and back-flow preventer. | | EXTERIOR: 34-1/4" x 43-7/8" x 42-13/16" (869mm x 1114mm x 1087mm) | | | | | |
| | | EXTERIOR WITH RETRACTABLE DOOR: 34-1/4" x 47-7/8" x 42-13/16" (869mm x 1216mm x 1087mm) | | | | | |
| | | INTERIOR: 20-5/16" x 23-1/2" x 28-7/16" (515mm x 596mm x 722mm) | | | | | |
| WATER REQUIREMENTS | | WATER QUALITY MINIMUM STANDARDS | | | | | |
| TWO (2) COLD WATER INLETS - DRINKING QUALITY ONE (1) TREATED WATER INLET: 3/4" NPT* ONE (1) UNTREATED WATER INLET: 3/4" NPT* LINE PRESSURE: 30 to 90 psi 2.8 to 6.2 bar WATER DRAIN: 1-1/2" CONNECTION WITH AIR GAP * Can manifold off of one 3/4" line. | | USING A WATER SUPPLY NOT MEETING ALTO-SHAAM'S MINIMUM WATER QUALITY STANDARDS WILL VOID THIS WARRANTY. It is the responsibility of the purchaser to ensure that incoming water supply is compliant with the specifications listed through adequate treatment measures. Installation of the CombiGuard™ Water Filtration System is recommended, but this system may not address all water quality issues present. | | | | | |
| CLEARANCE REQUIREMENTS | | Contaminant | | Inlet Water Requirements (untreated water) | | | |
| LEFT: 6" (152mm) PLUS SERVICE ACCESS: 18" (457mm) RECOMMENDED 20" (508mm) FROM HEAT PRODUCING EQUIPMENT RIGHT: 4" (102mm) TOP: 20" (508mm) FOR AIR MOVEMENT BACK: 4" (102mm) BOTTOM: 5-1/8" (130mm) FOR LEGS COUNTER-TOP INSTALLATIONS MUST MAINTAIN 4" (102mm) MINIMUM CLEARANCE FROM COUNTER SURFACE. | | Free Chlorine | Less than 0.1 ppm (mg/L) | | | | |
| | | Hardness | Less than 3 gpg (52 ppm) | | | | |
| | | Chloride | Less than 30 ppm (mg/L) | | | | |
| | | pH | 7.0 to 8.5 | | | | |
| | | Alkalinity | Less than 50 ppm (mg/L) | | | | |
| | | Silica | Less than 12 ppm (mg/L) | | | | |
| | | Total Dissolved Solids (tds) | Less than 60 ppm | | | | |
| ELECTRICAL | | 7 • 14 Esi | | 7 • 14 Esi/sk | | | |
| VOLTAGE | PHASE | CYCLE/HZ | AWG | AMPS | kW | AMPS | kW |
| 208-240 | at 208 | 1* | 2 Wire plus ground AWG 3 | 67.0 | 13.9 | 69.2 | 14.4 |
| | at 240 | | | 77.0 | 18.4 | 79.0 | 18.9 |
| 208-240 | at 208 | 3 | 3 Wire plus ground AWG 6 | 38.6/ph | 13.9 | 40.0/ph | 14.4 |
| | at 240 | | | 44.3/ph | 18.4 | 45.5/ph | 18.9 |
| 380-415 | at 380 | 3 | 4 Wire plus ground AWG 10 | 21.1/ph | 13.9 | 22.0/ph | 14.4 |
| | at 415 | | | 25.6/ph | 18.4 | 26.3/ph | 18.9 |
| 440-480 | at 440 | 3* | 3 Wire plus ground AWG 8 | 20.0/ph | 15.4 | 21.0/ph | 15.9 |
| | at 480 | | | 22.0/ph | 18.4 | 23.0/ph | 18.9 |
| * ELECTRICAL SERVICE CHARGE APPLIES | | | | | | | |
| WEIGHT | | CAPACITY | | | | | |
| NET | 436 lb (198 kg) | FULL-SIZE PANS: 20" x 12" x 2-1/2" GN 1/1: 530 x 325 x 65mm GN 2/1: 650 x 530 x 65mm | | Fourteen (14) | Twelve (12) | | |
| SHIP | 560 lb (254 kg) | FULL-SIZE SHEET PANS:* 18" x 26" x 1" ON WIRE SHELVES ONLY | | Fourteen (14) | Twelve (12) | | |
| CRATE | 42" x 50" x 46" EST. | | | Seven (7) | Five (5) | | |
| DIMENSIONS: | (1067 x 1270 x 1168mm) | | | Seven (7) | Six (6) | | |
| | | 168 lb (76 kg) MAXIMUM | | | | | |
| | | VOLUME MAXIMUM: 105 QUARTS (133 LITERS) | | | | | |

* ADDITIONAL WIRE SHELVES REQUIRED FOR MAXIMUM CAPACITY

ELECTRIC COMBITHERM — INSTALLATION MANUAL #7001

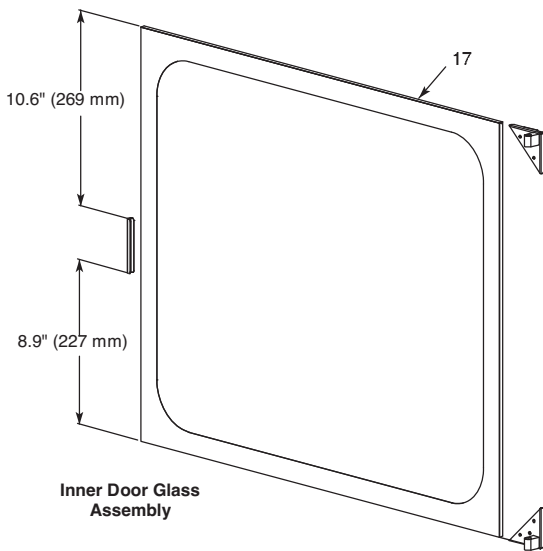
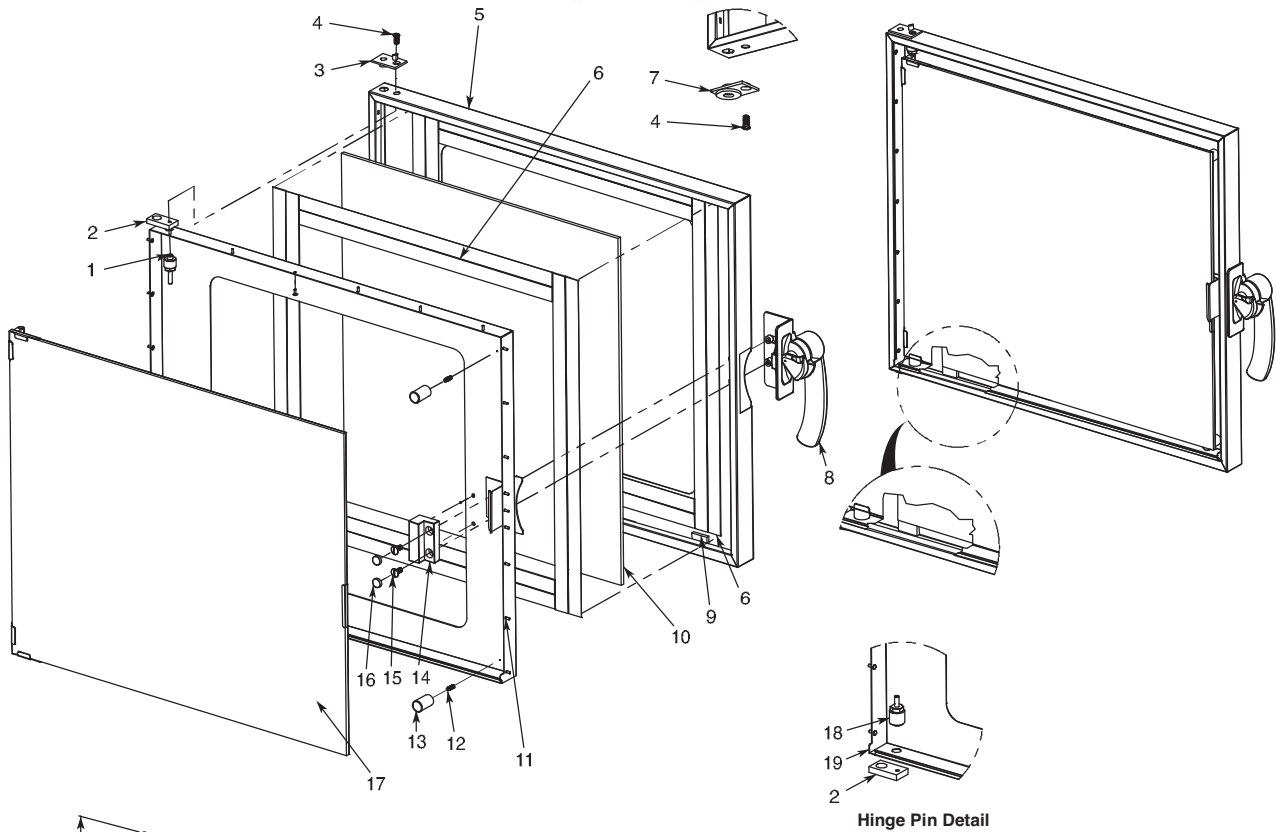

| Item | Part | Description | Qty. |
|------|----------|---|------|
| 1 | PI-26973 | Pin, Upper | 1 |
| 2 | HG-25078 | Hinge, CT, Anchor, ML Combis | 2 |
| 3 | HG-25077 | Hinge, CT, Top Stop, ML Combi | 1 |
| 4 | SC-22282 | Screw, CT, 1.0X 16 mm, PH Oval, HD N/S 18-8, DIN # 966A | 2 |
| 5 | 1005957 | Outer Panel, Door | 1 |
| 6 | TA-25125 | Tape, Double Sided | 2 |
| 7 | HG-25079 | Hinge, CT, Upper Ratchet, Combi | 1 |
| 8 | HD-26966 | Handle, Door, Right, Combi '06 | 1 |
| 9 | BM-27116 | Bumper | 2 |
| 10 | GL-27110 | Glass, Outer Door, 7.14 EP | 1 |
| 11 | RI-27108 | Rivet, Sealed | 22 |
| 12 | SC-25091 | Screw, CT, M5X16, DIN 551, A2 S/S, SLTD Set Screw Flat PT | 2 |
| 13 | BM-27146 | Bumper Stop/Inner Door | 2 |
| 14 | SP-27212 | Spacer, Window Latch | 1 |
| 15 | SC-27125 | Screw, Truss Head, S/S | 2 |
| 16 | PG-24789 | Plug, 15 mm | 2 |
| 17 | 5005090 | Inner Door, Glass Assembly | 1 |
| 18 | PI-26974 | Pin, Lower | 1 |
| 19 | 5005089 | Inner Door Spot RH | 1 |
| * | CL-27854 | Inner Door Latch | 1 |

*Item Not Shown

PARTS INFORMATION

RECESSED DOOR ASSEMBLY (812)987-08-81

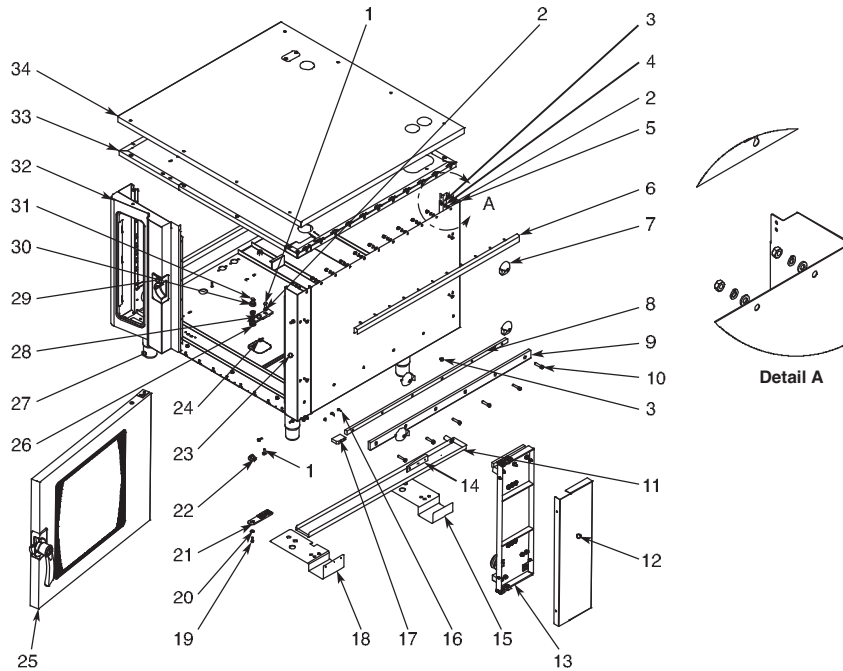

| Item | Part | Description | Qty. |
|------|----------|--------------------------------|------|
| 1 | SC-22924 | M6 x 20 Hex Trim HD | 2 |
| 2 | WS-22297 | Washer, Flat, M6, DIN 125 | 14 |
| 3 | NU-22291 | M6-1.0 x Hex S/S Nut 18-8 | 12 |
| 4 | WS-22302 | Washer, Lock, M6, DIN 127B | 12 |
| 5 | 5008015 | Right Side Assembly | 1 |
| 6 | 5007897 | Channel Assembly | 1 |
| 7 | BK-27412 | Recessed Door Block | 4 |
| 8 | RA-28207 | Rail, Top | 1 |
| 9 | RA-28208 | Rail, Bottom | 1 |
| 10 | SC-24388 | Screw, SHC M8 x 35 S/S | 6 |
| 11 | 5007893 | Drip Pan Assembly | 1 |
| 12 | 1008869 | Cover, Trolley | 1 |
| 13 | 5008001 | Trolley Assembly | 1 |
| 14 | BK-22100 | White Teflon, Cart Guide Block | 1 |
| 15 | 1008505 | Rear Bracket, Recessed | 1 |
| 16 | SC-22281 | Screw, M5 x 16 Flat Head CSink | 2 |
| 17 | BK-28252 | Block, Guide | 1 |

| Item | Part | Description | Qty. |
|------|----------|----------------------------|------|
| 18 | 1008506 | Front Bracket Recessed | 1 |
| 19 | SC-22284 | Screw, M6 x 16 Hex S/S HD | 1 |
| 20 | WS-22298 | Washer, M8, 18-8 | 1 |
| 21 | HG-28040 | Hinge | 1 |
| 22 | HG-25101 | Hinge, Lower Ratchet | 1 |
| 23 | 5008014 | Front Corner Assembly | 1 |
| 24 | SC-26060 | M5 x 16 Hex Head | 4 |
| 25 | 5008004 | Door Assembly Recessed | 1 |
| 26 | WS-25124 | Eccesntric Washer | 1 |
| 27 | LG-26867 | Legs, Combi | 4 |
| 28 | HG-28041 | Hinge | 1 |
| 29 | LT-26968 | Latch, Door, Right | 1 |
| 30 | WS-25127 | Covering Washer, For Hinge | 1 |
| 31 | PG-25132 | M12, (Black or Natural) | 1 |
| 32 | PE-27559 | Front Panel Weld Assembly | 1 |
| 33 | 5005065 | Fill In Cover Assembly | 1 |
| 34 | 5007895 | Outer Cover Assembly | 1 |

Зип Общепит

vsezip.ru

PARTS INFORMATION

DIRECTIONAL PANEL ASSEMBLY

7(812)987-08-81

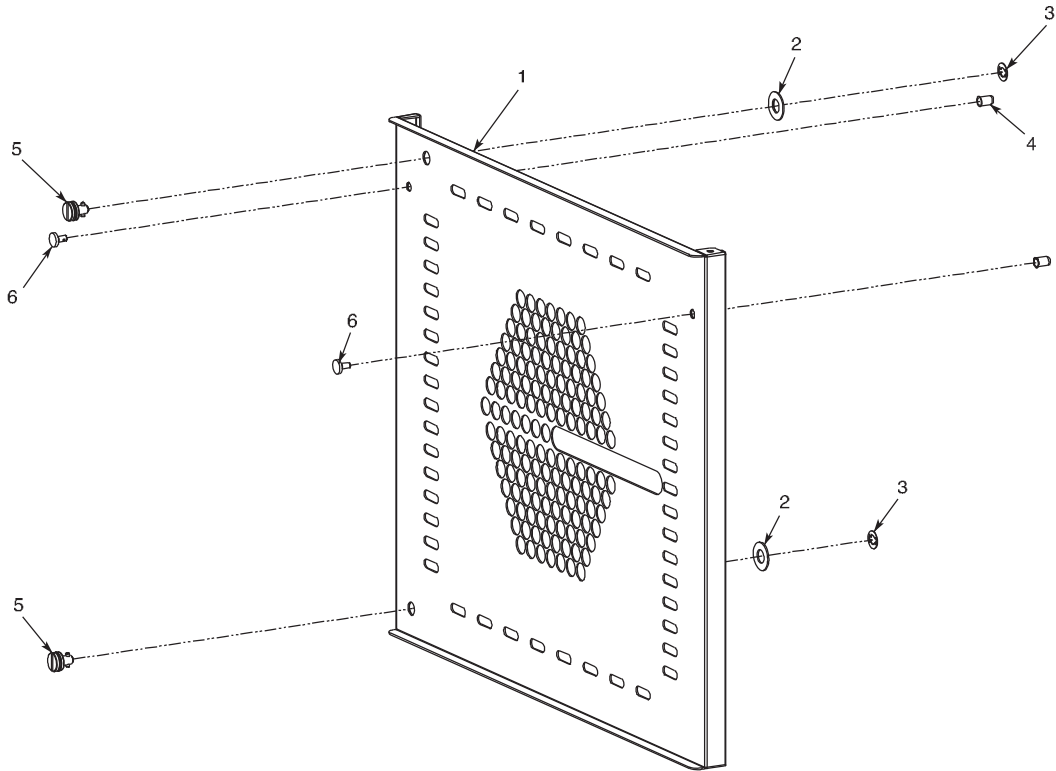

| Item | Part | Description | Qty. |
|------|----------|--|------|
| 1 | 1006361 | Directional Panel, 7.14 l | 1 |
| 2 | 1006601 | Directional Panel Spacer, 16 GA | 2 |
| 3 | WS-24090 | Holding (Lock Clip), All Combitherm's ML | 2 |
| 4 | NU-22770 | Nut, Threaded Insert, M6 | 2 |
| 5 | CL-24089 | Clip, CT, ML, Lock, W/3 Washers | 2 |
| 6 | SC-22753 | Screw, SS Round, Hanging Rack | 2 |

PARTS INFORMATION

PRESSURE BOX ASSEMBLY 7(812)987-08-81

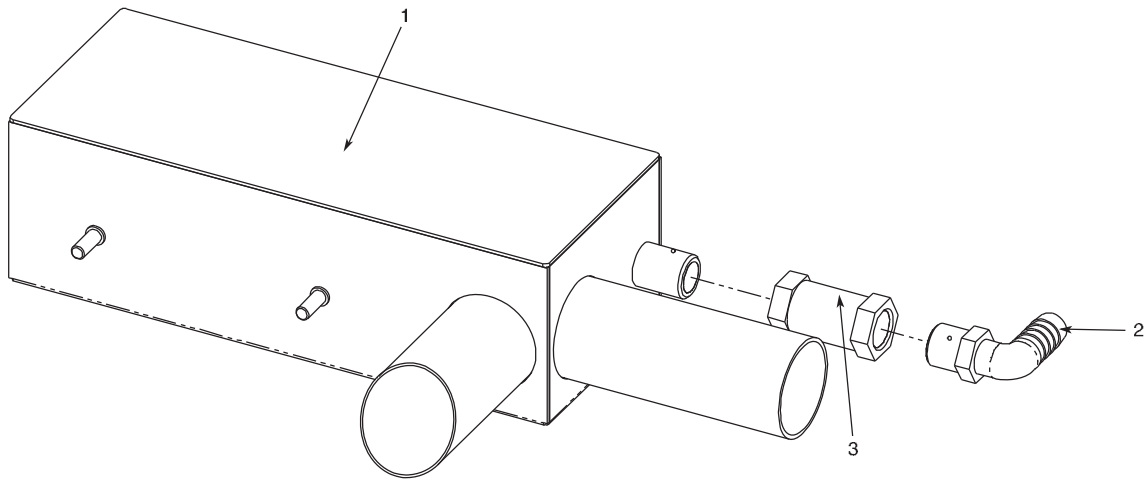
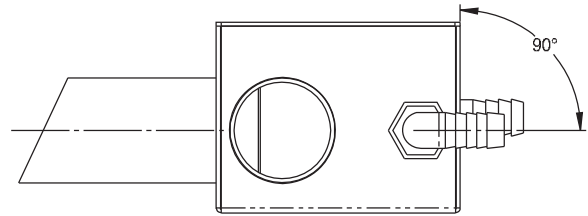

| Item | Part | Description | Qty. |
|------|----------|-------------------------------------|------|
| 1 | 5005009 | Pressure Box | 1 |
| 2 | EB-25551 | Elbow, Nylon, 1/2" x 3/8" | 1 |
| 3 | VA-25549 | Valve, 3/8", Flow Control, 0.12 GPM | 1 |

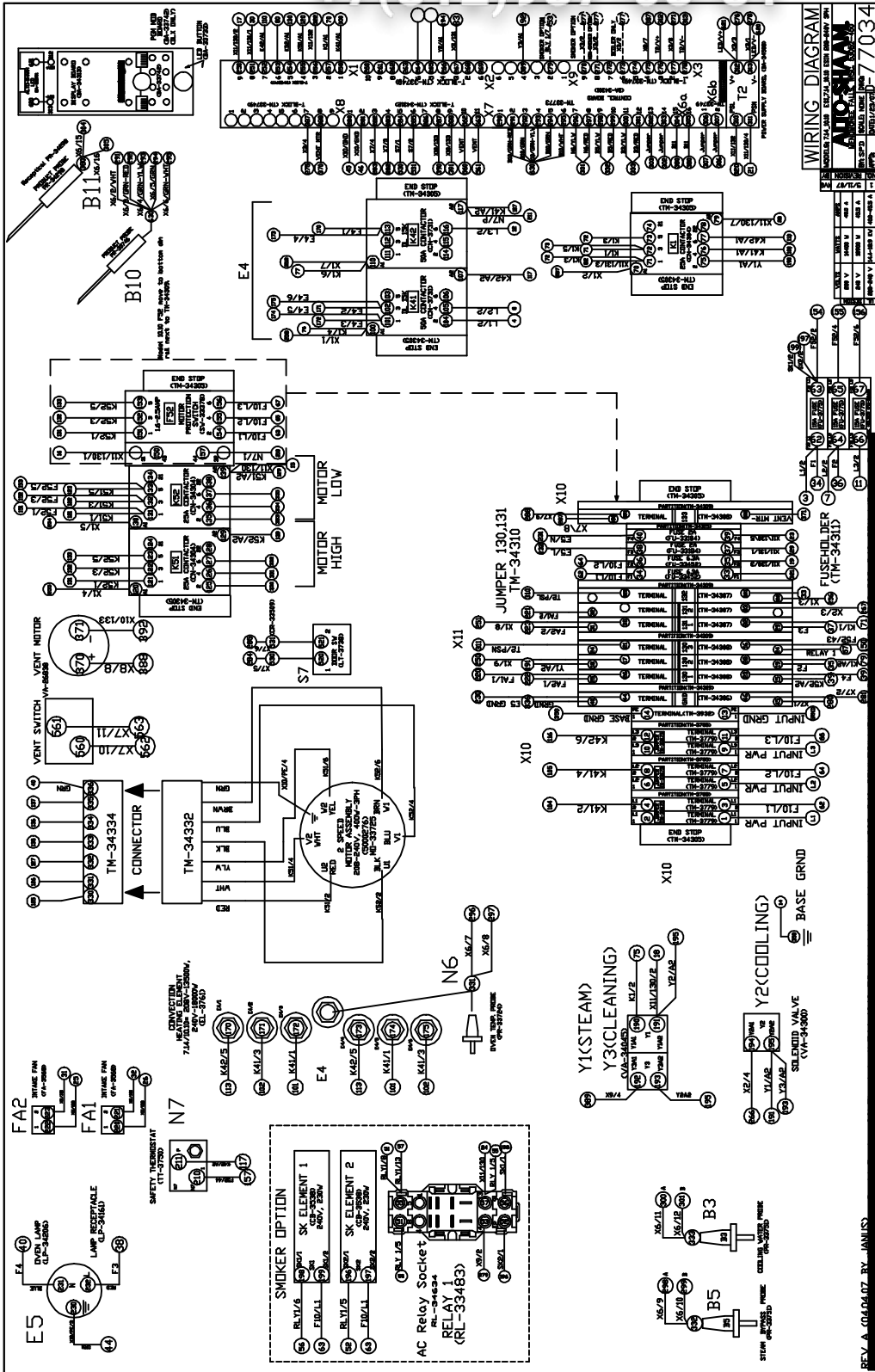

Зип Общепит

vsezip.ru

+7(812)987-08-81

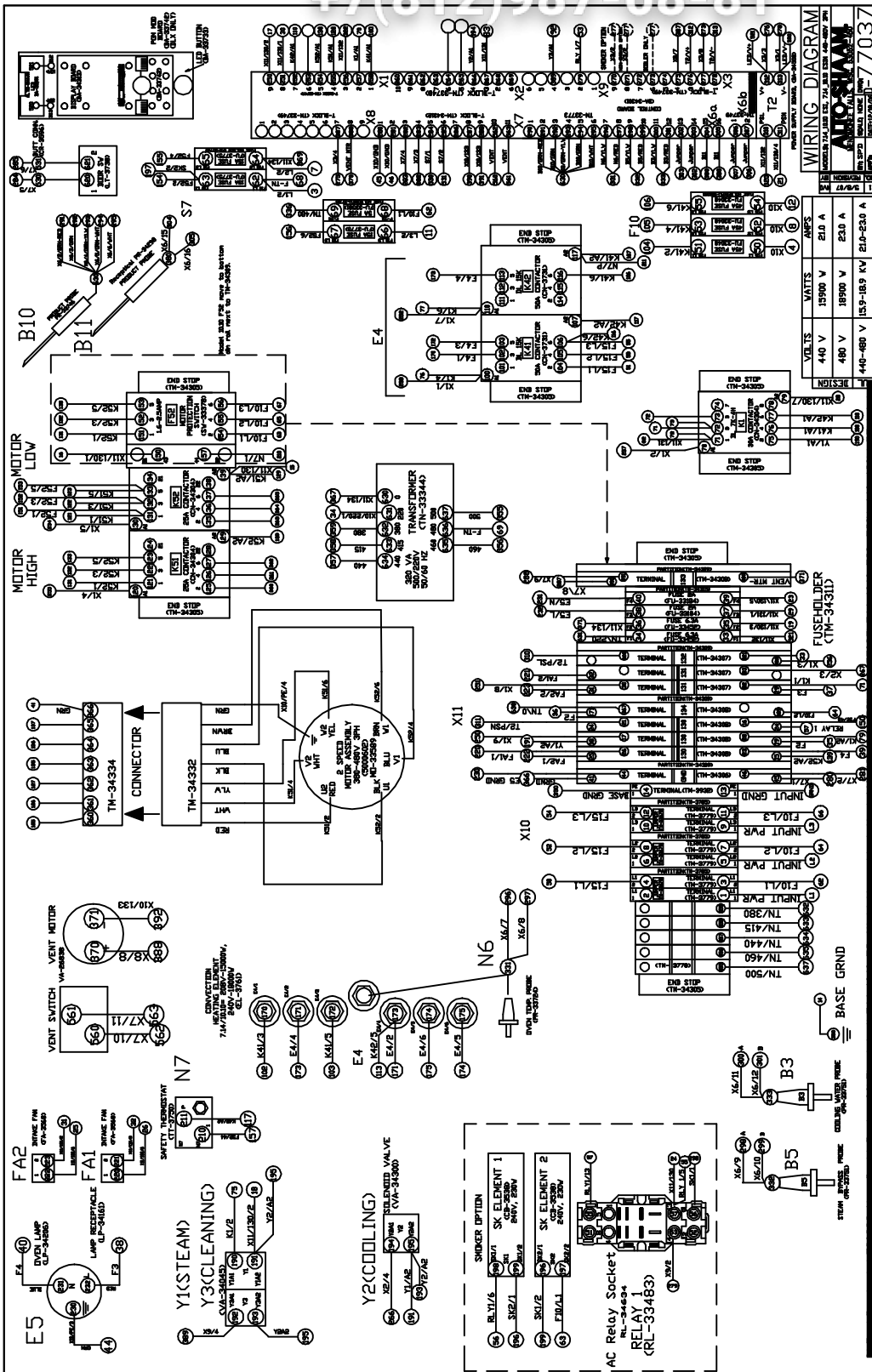

+7(812)987-08-8

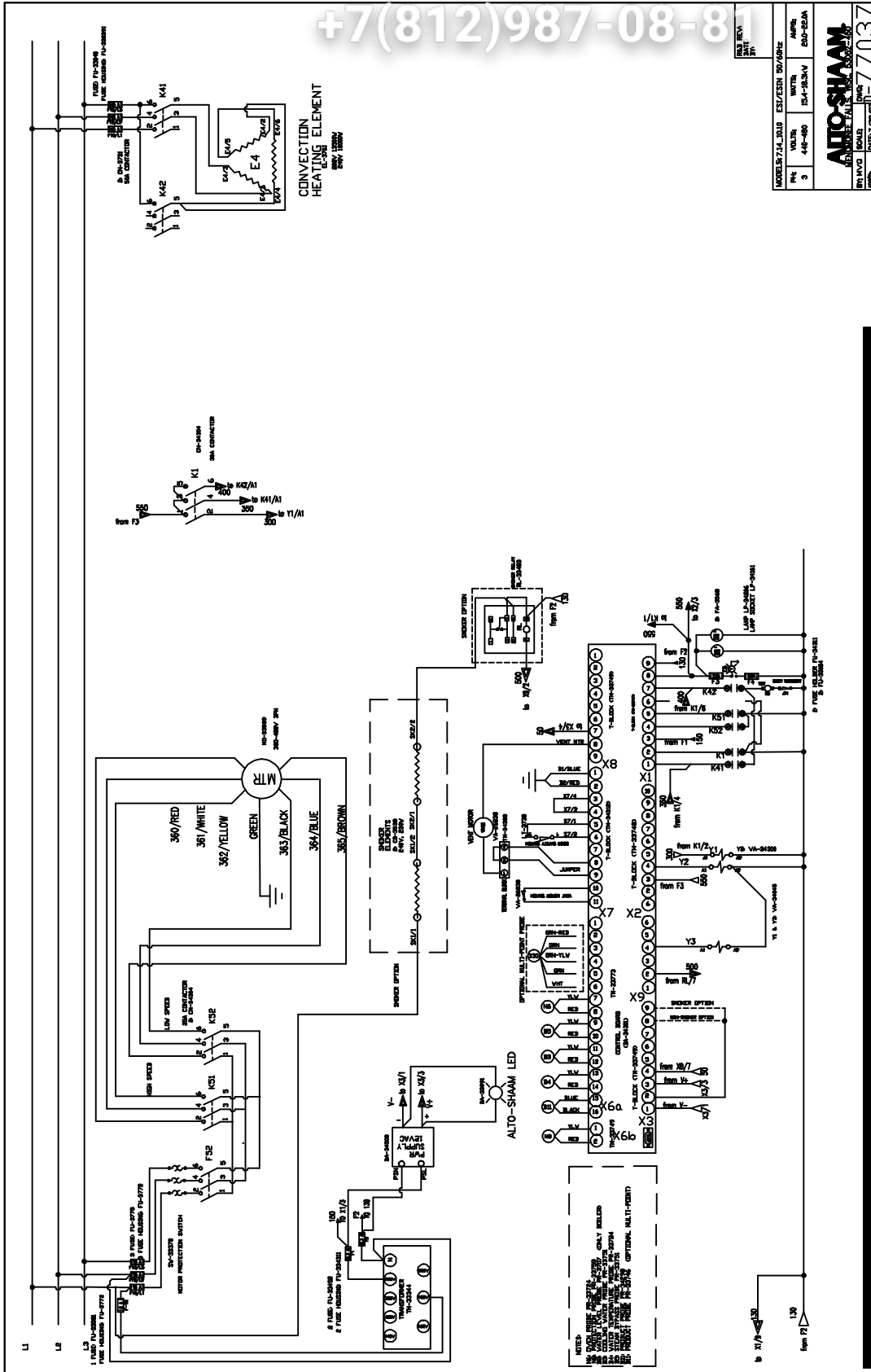

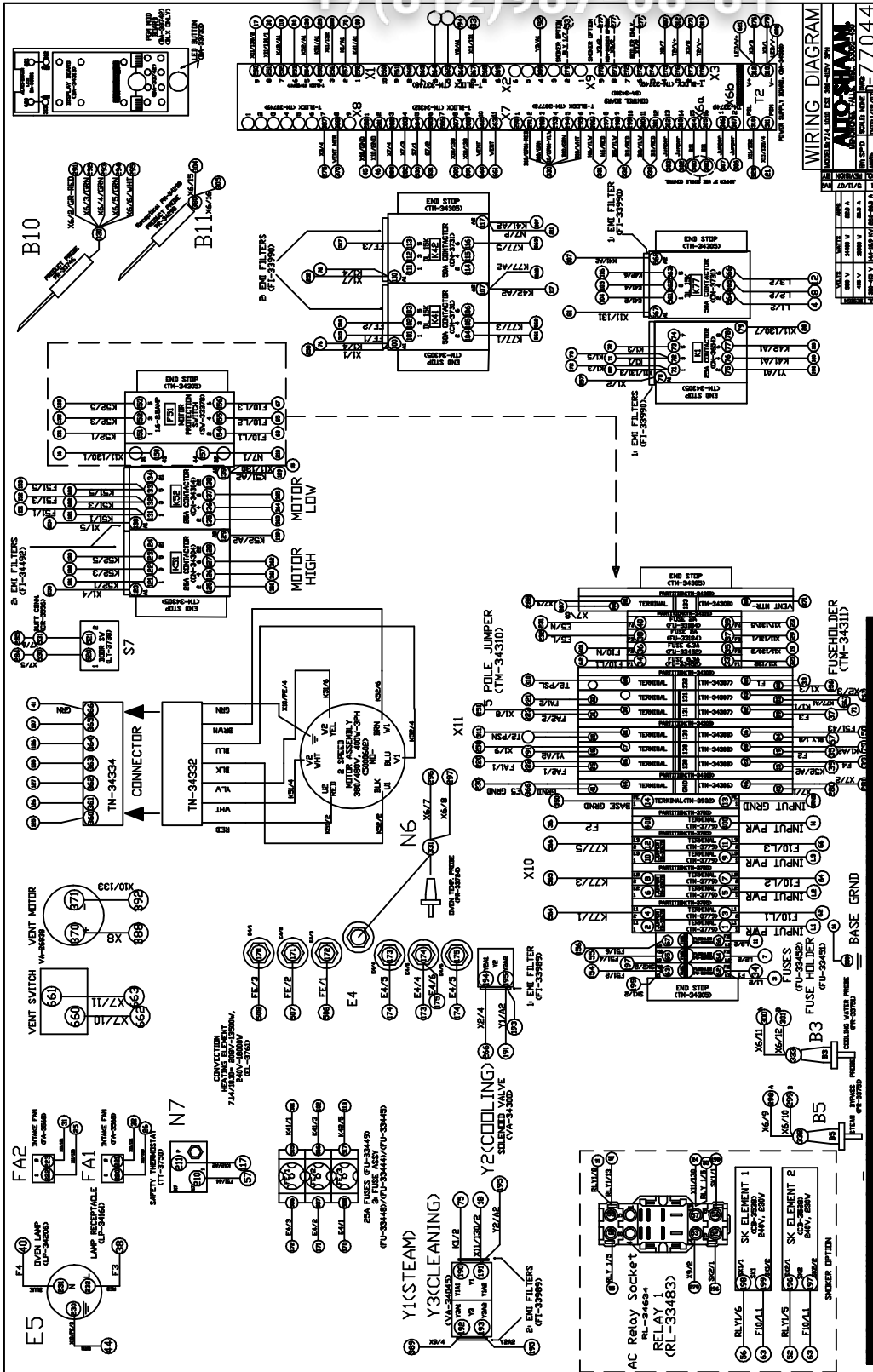

WIRING DIAGRAM
MODEL 74-300 EST. 200-000 001
DATE: 10/10/00
REV: 1
BY: [Signature]
7044

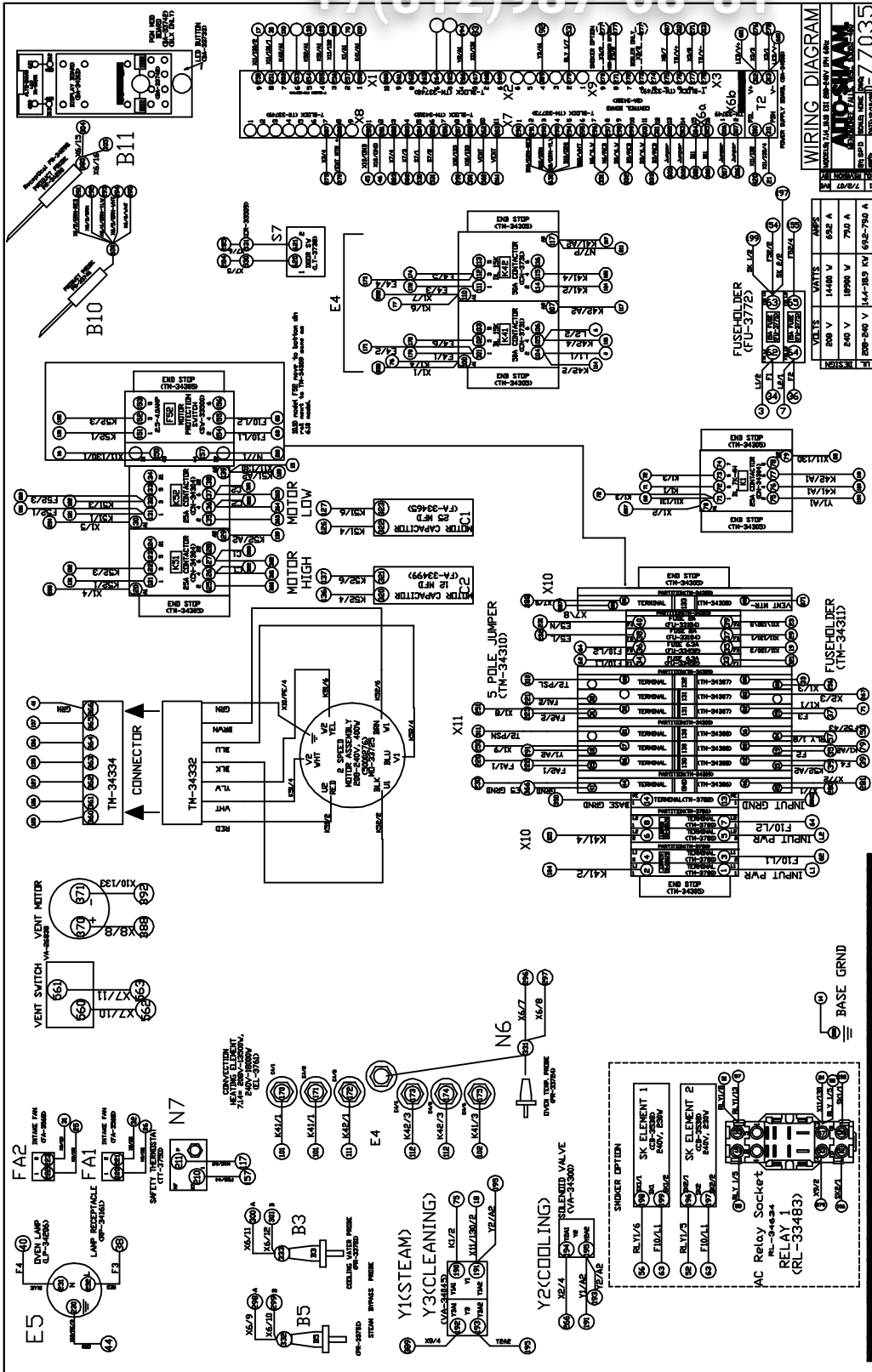

Зип Общепит

vsezip.ru

+7(812)987-08-81

| | | | |
|---------|-----------|----------|-------------|
| MODELS: | 714.10.10 | ESI/ESIN | 50/60HZ |
| PH: | 1 | VOLTS: | 208-240 |
| BY: | M.V.G | WATTS: | 14.4-18.9kW |
| APPD: | | SCALE: | 692-790A |
| | | DATE: | 7/20/07 |
| | | DWG: | 50097-150 |
| | | WISC: | 50097-150 |

AUTO-SHAM
MILWAUKEE FALLS, WISCONSIN 53097-1500

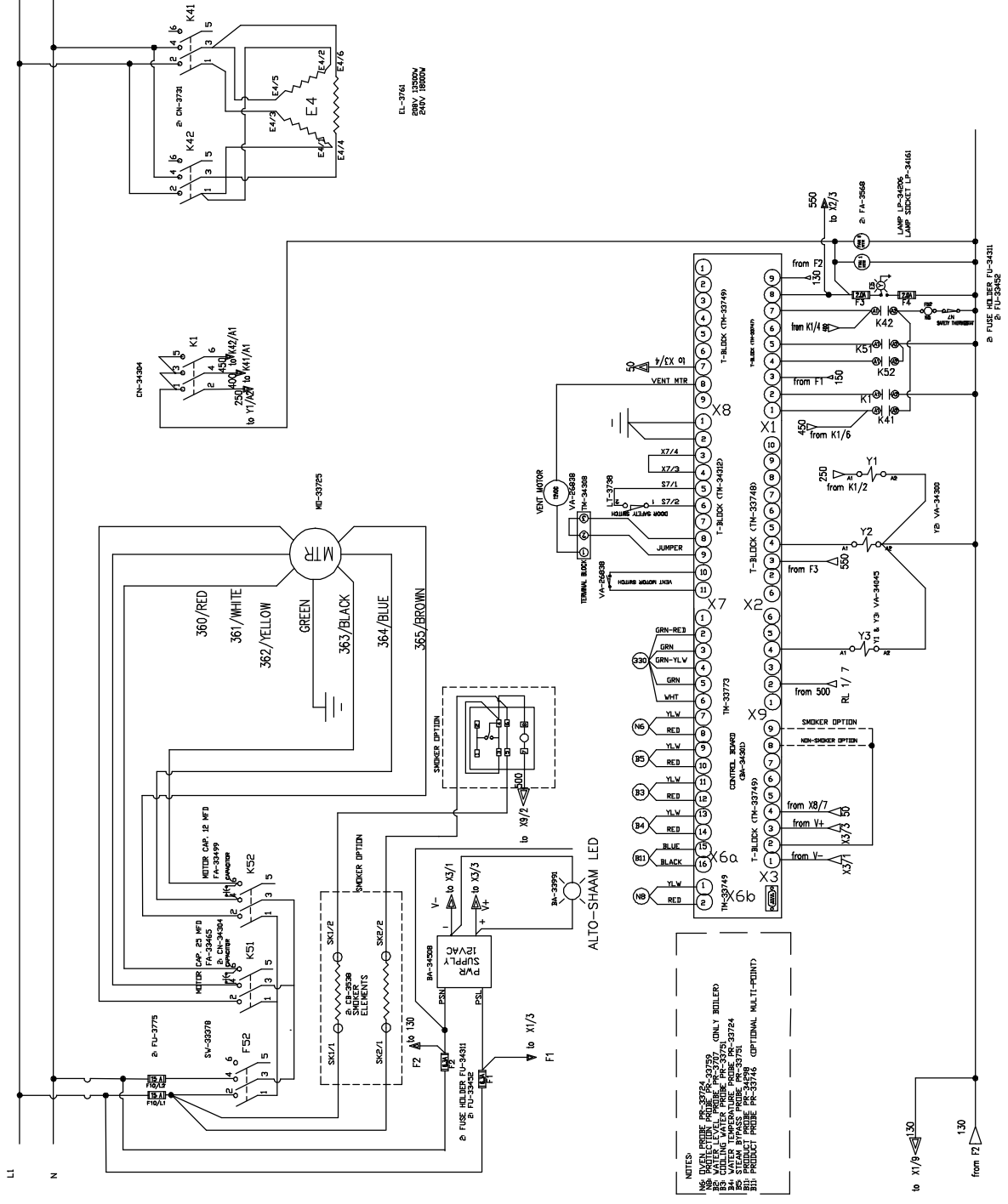

NOTES:
 1. 12V AC SUPPLY (BA-24008) (ONLY BUILTERS)
 2. 500V AC SUPPLY (VA-26688) (ONLY BUILTERS)
 3. CHILLING WATER PROBE (PR-32724)
 4. STEAM TRAP PROBE (PR-32725)
 5. STEAM BYPASS PROBE (PR-32726)
 6. PRODUCT PROBE (PR-32727) (OPTIONAL MULTI-POINT)