

Зип Общепит

PARTI DI RICAMBIO
PIECES DETACHEES
SPARE PARTS
ERSATZTEILE
LISTA DE RECAMBIOS

vsezip.ru

LC 700

LC 900

LC 1200

PRODUCTION START 10/03

NEW DESIGN 04/05

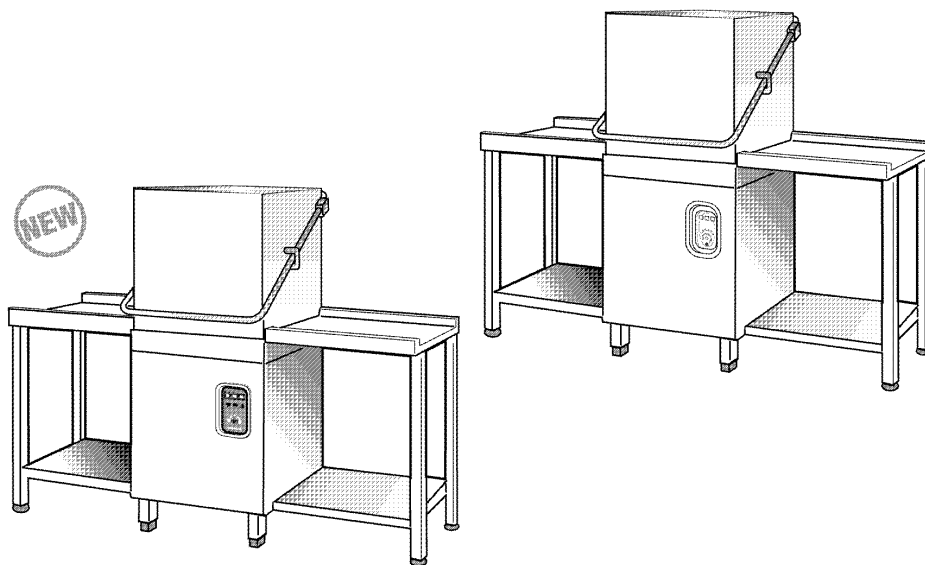

COMENDA

04 - 2005 | S. AG.

Зип Общепит

2 - Hood/Tank

vsezip.ru

+7(812)987-08-81

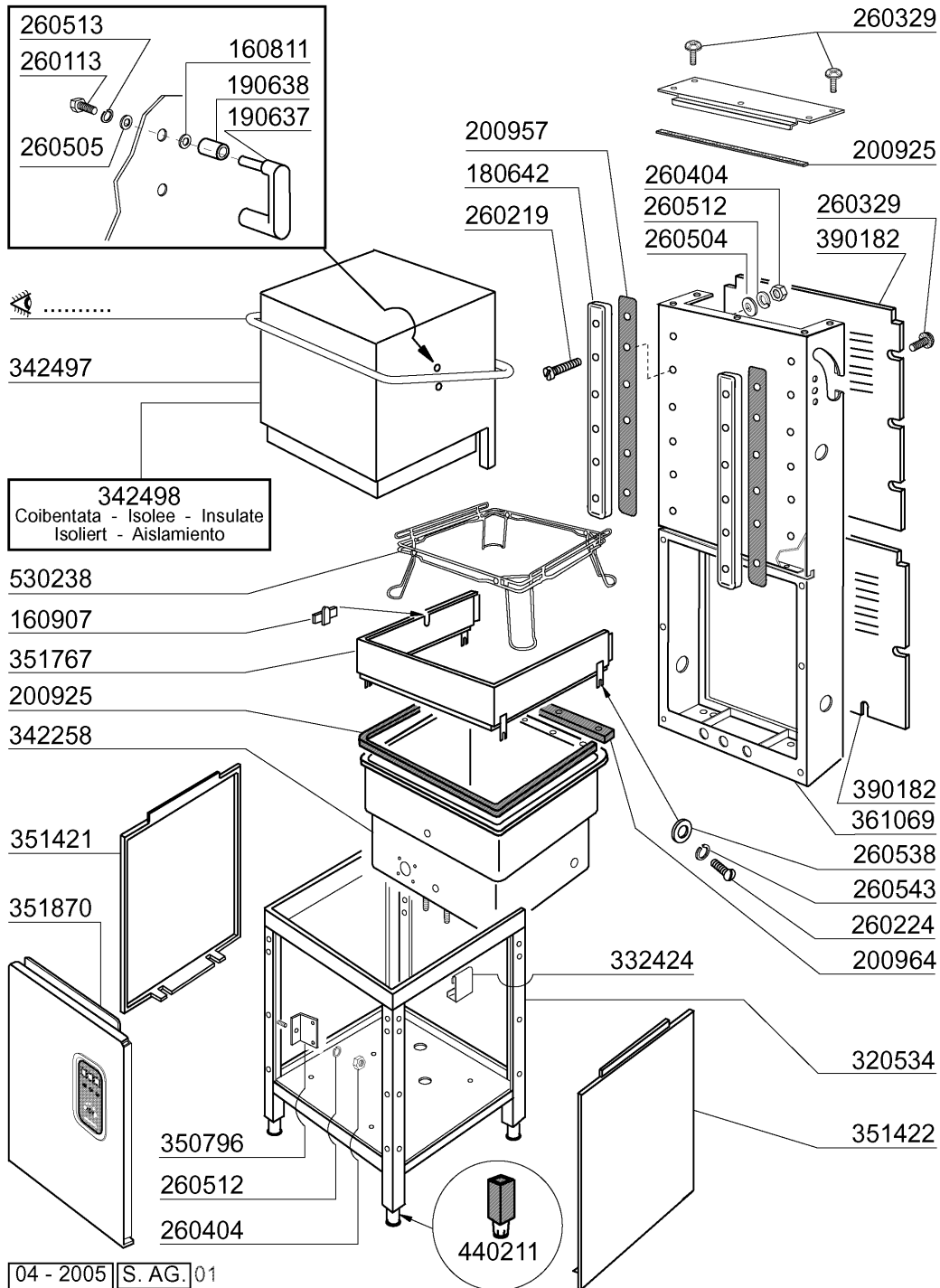

Зип Общепит

2 - Hood/Tank

vsezip.ru

CODE	DESCRIPTION
160811	WASHER F2 16X3,5X1 ALCOF
160907	CONNECTION FOR TABLE C95-155
180642	GUIDE
190637	GUIDE FOR DOOR "C"
190638	ROLLER FOR "C" DOOR GUIDE
200925	GASKET
200957	GASKET
200964	GASKET 618X14 SP.2
260113	STAINL.ST.TE SCREW 8X20 A2 UNI
260219	STAINL.ST TCP SCREW 6X35 A2 UN
260224	TB-SCREW 6X15 B23-10-11-12
260329	VITE M5X12 SPEC.ZIGR.SOTTOTEST
260404	STAINLESS STEEL NUTS D6 UNI 55
260504	ST/ST FLAT WASHER D6
260505	STAINL.STEEL FLAT WASHER D8
260512	ST/ST GROWER WASHER D6
260513	GROWER WASHER D8
260538	WASHER 18X6X1,5 ST/ST
260543	WASHER D.6 ST/ST
320534	LOWER FRAME
332424	SQUADRETTA SOST.TUBO PRESS.C
342258	TANK
342497	HOOD
342498	INSULATED HOOD
350796	BRACKET F. RELAY SUPPORT S
351421	LEFT PANEL
351422	RIGHT PANEL
351767	FRONT PANEL
351870	FRONT PANEL LC2004
361069	BACK FRAME
390182	BACK PANEL
440211	LEGS
530238	RACK SUPPORT C-SERIES

Зип Ощепит

3 - Tank

vsezip.ru

+7(812)987-08-81

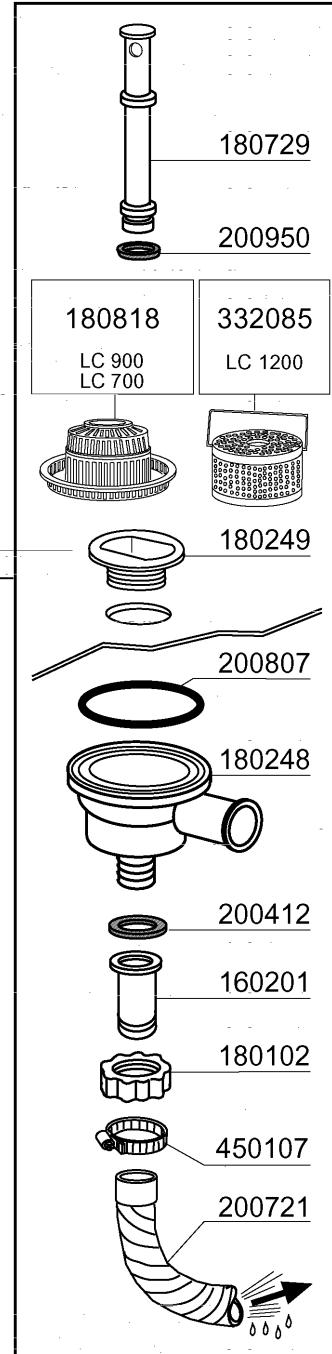
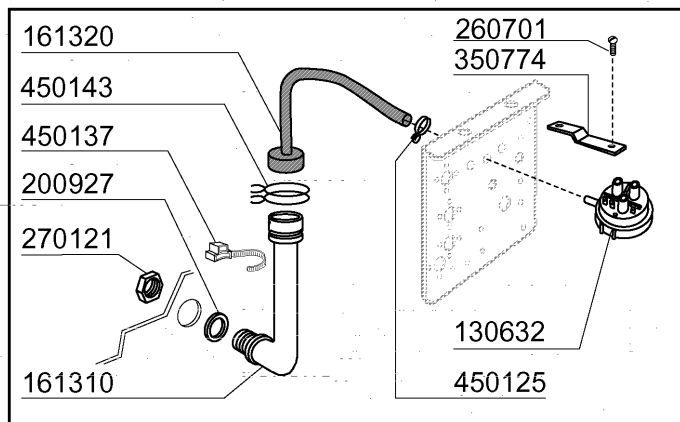
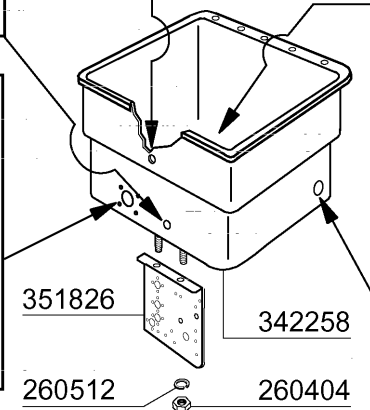
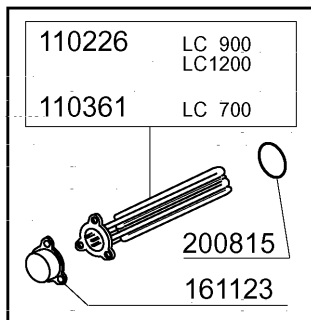
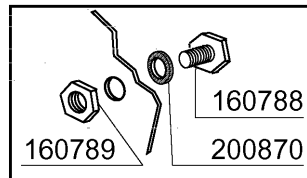
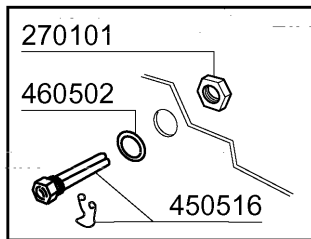
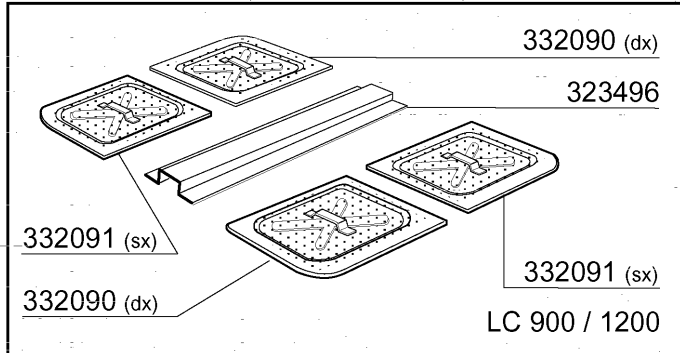

04 - 2005 | S. AG.

Зип Общепит

3 - Tank

vsezip.ru

CODE	DESCRIPTION
110226	HEAT. ELEMENT 3000W 230/400V
110361	HEAT. ELEMENT 2200W 230V
130632	PRESSURE SWITCH 1L
160201	ELBOW F.TANK INLET MOPLN
160788	PLUG
160789	NUT
161123	HEAT.ELEMENT COVER H42 SNL
161310	AIR CHAMBER FOR GLASSWASHERS B
161320	HOSE FOR AIR CHAMBER
180102	DRAIN PIPE NUT 1"1/2 F45-55
180248	SUCTION TANK
180249	NUT
180729	OVERFLOW PIPE
180818	STRAINER FOR FC
200412	GASKET DRAIN 11/2" 45X33X3
200721	DRAIN HOSE 28X35 2MT.
200807	O-RING 3,53 X 110,72
200815	O-RING F. HEAT.ELEM.
200870	GASKET 18X10X2
200927	GASKET FOR AIR TRAP
200950	VITON GASKET
260404	STAINLESS STEEL NUTS D6 UNI 55
260512	ST/ST GROWER WASHER D6
260701	SCREW 3,5X9,5
270101	HEXAGON LOCK NUT 1/2"
270121	NUT FOR AIR TRAP
323496	STRAINERS SUPPORT
332085	STRAINER LC
332090	RIGHT STRAINER
332091	TANK LEFT STRAINER
342258	TANK
350774	BRACKET
351826	BRACKET
450107	CLAMP FE ZN 38-50 H=12,2
450125	ELASTIC CLAMP D. 10,4X9,8
450137	COLLAR CONNECTION WITH BASE 31
450143	CLAMP D.39,7 X 37,7
450516	THERMOSTAT SHIELD FOR 2 TERMOS
460502	GASKET 30X21X2

Зип Общепит

4 - Handle

vsezip.ru

+7(812)987-08-81

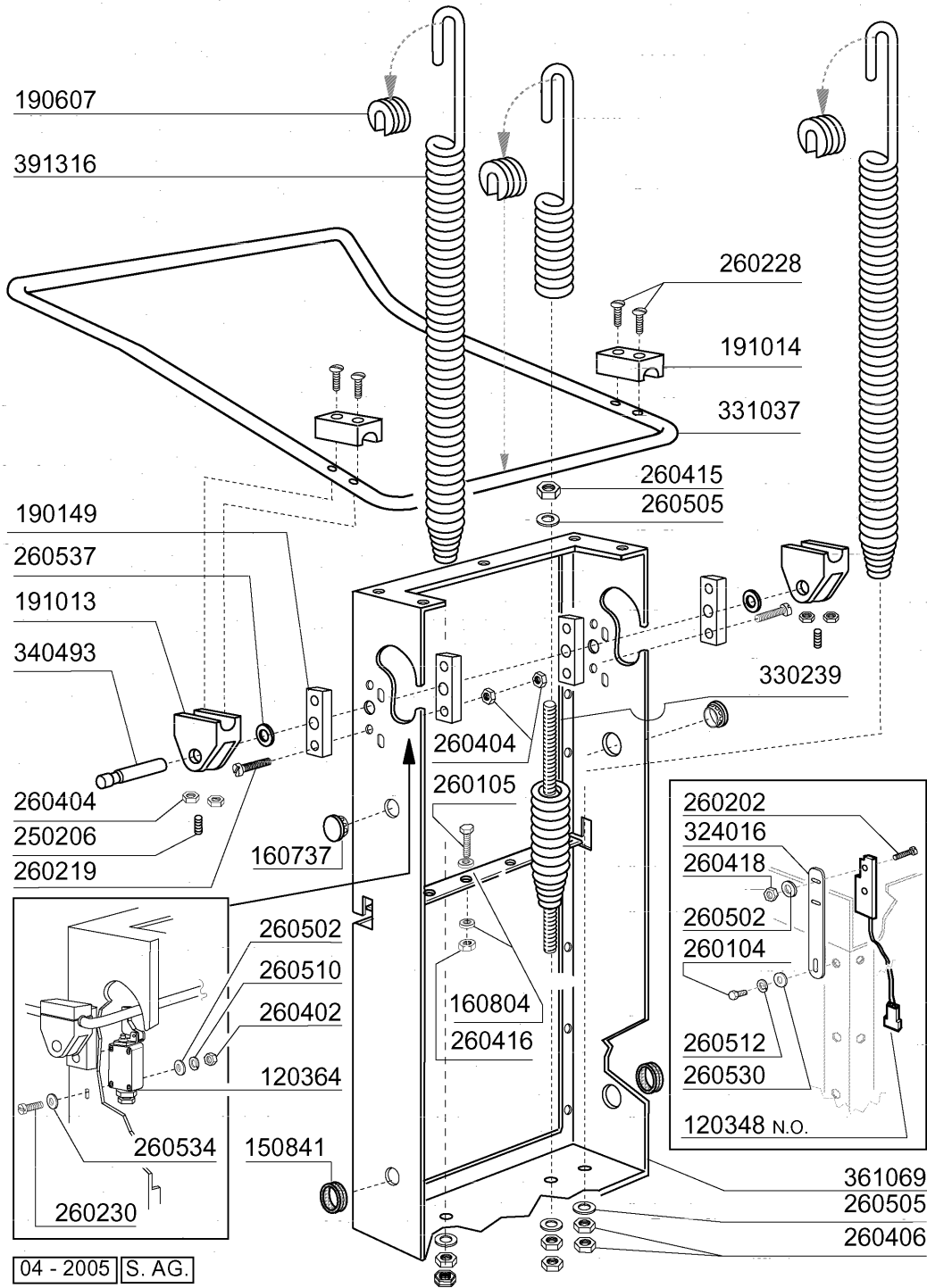

04 - 2005 | S. A.G.

Зип Общепит

4 - Handle

vsezip.ru

CODE	DESCRIPTION
120348	MAGN.SWITCH (NO)
120364	LIMIT SWITCH WITH LEVER
150841	CABLE HOLDER
160737	PLUG HEYCO D.34,9
160804	GASKET D.6
190149	REINFORCEMENT FOR HANDLE SUPP.
190607	HANDLE BUSH C30-70
191013	HINGE F. SUPPORT C30-C70
191014	FLANGE F. HANDLE C30-70
250206	GRUB SCREW D.6
260104	STAINL.ST TE-SCREW A2 6X16 UNI
260105	SCREW TE 6X20
260202	SCREW TCP 3X16
260219	STAINL.ST TCP SCREW 6X35 A2 UN
260228	STAINL.ST SPECIAL SCREW 6X42 3
260230	SCREW TCP 4X40
260402	STAINLESS STEEL NUT D4 UNI 55
260404	STAINLESS STEEL NUTS D6 UNI 55
260406	NUT 8MA
260415	STAINLESS STEEL SELF-LOCKING N
260416	STAINLESS STEEL NUTS M6
260418	SELF-LOCKING NUT M4
260502	S/S FLAT WASHER D.4
260505	STAINL.STEEL FLAT WASHER D8
260510	GROWER WASHER D.4
260512	ST/ST GROWER WASHER D6
260530	STAINL.ST WASHER 7X22X2
260534	WASHER
260537	STAINL.STEEL FLAT WASHER D13X2
324016	SWITCH BRACKET
330239	ROD
331037	HANDLE C95-155-165 ISOLATED
340493	PIN F. HINGE C30
361069	BACK FRAME
391316	SPRING FOR HANDLE C85/140-G75

Зип Общепит

5 - Wash/Rinse column

vsezip.ru

+7(812)987-08-81

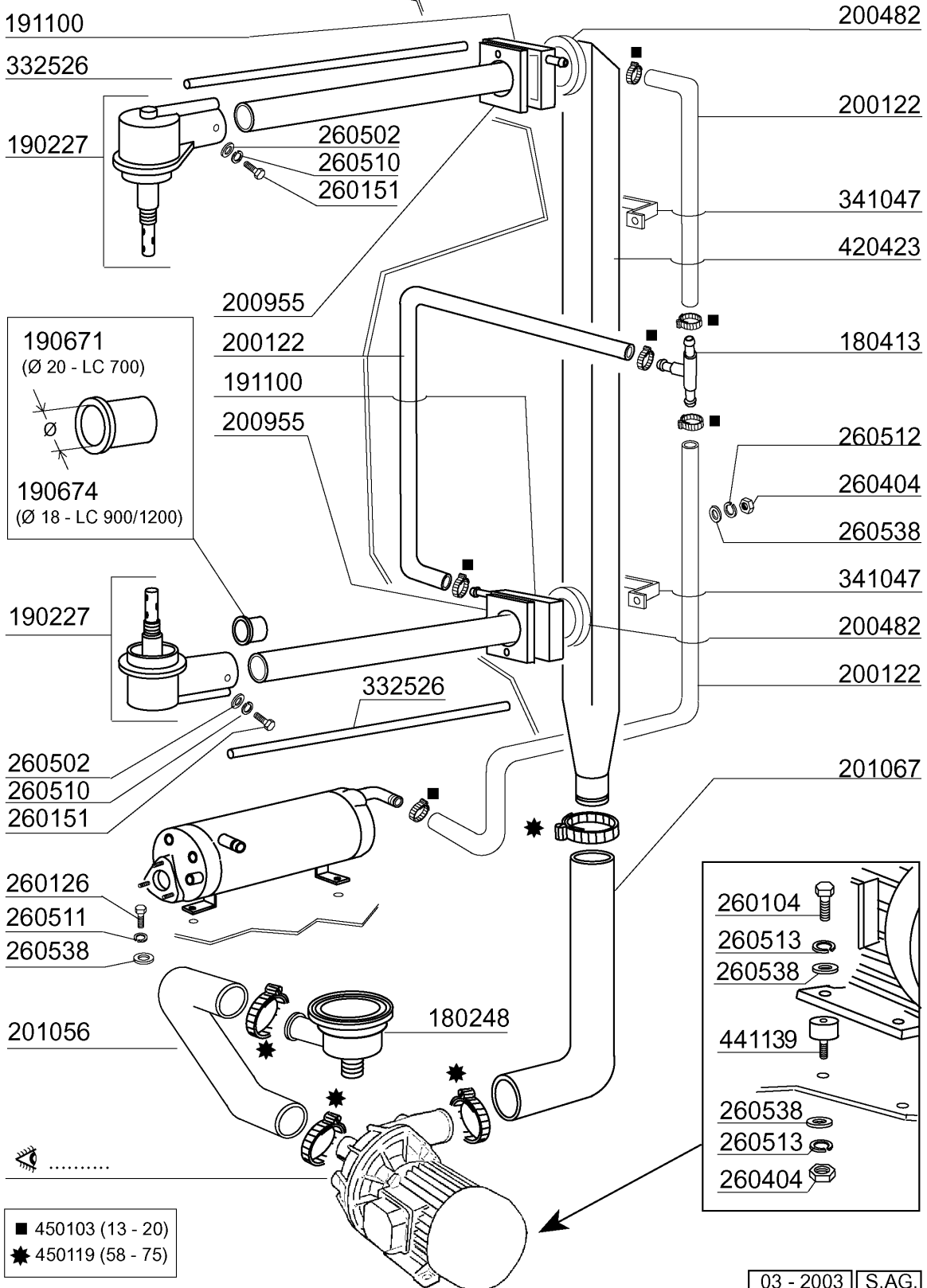

Зип Общепит

5 - Wash/Rinse column

vsezip.ru

CODE	DESCRIPTION
180248	SUCTION TANK
180413	TEE NIPPLE D. 1,5 - RINSE ASSE
190227	ARM SUPPORT
190671	BUSH
190674	BUSH
191100	RINSE COLLECTOR C-LC
200122	HOSE 11X19
200482	GASKET 60X54 RAMP C140
200955	GASKET
201056	WASH PUMP INLET HOSE
201067	OUTLET HOSE
260104	STAINL.ST TE-SCREW A2 6X16 UNI
260126	SCREW TE 5X12
260151	SCREW TE 4X12
260404	STAINLESS STEEL NUTS D6 UNI 55
260502	S/S FLAT WASHER D.4
260510	GROWER WASHER D.4
260511	GROWER WASHER D.5
260512	ST/ST GROWER WASHER D6
260513	GROWER WASHER D8
260538	WASHER 18X6X1,5 ST/ST
332526	RINSE HOSE
341047	U-BOLT FOR WASH.RAMP
420423	WASH RAMP C/LC
441139	VIBRATION-DAMPING FEET 25X20X6
450103	CLAMP FE ZN. 13-20 H=9
450119	CLAMP FE ZN. 58-75 H=12,2

Зип Общепит

6 - Wash arm

vsezip.ru

+7(812)987-08-81

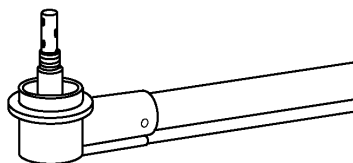
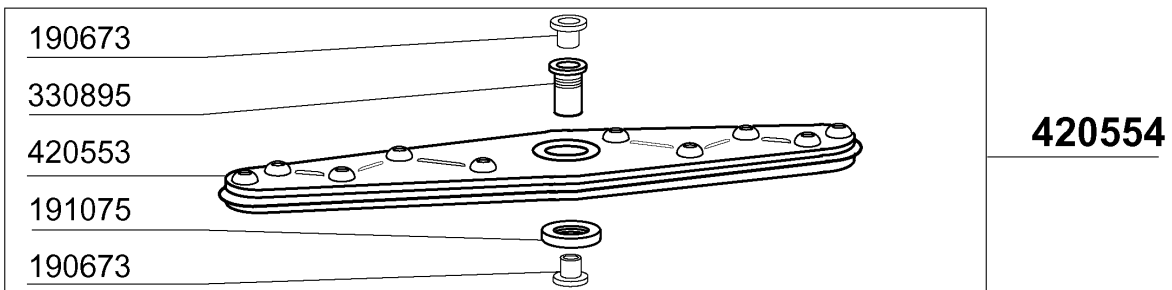
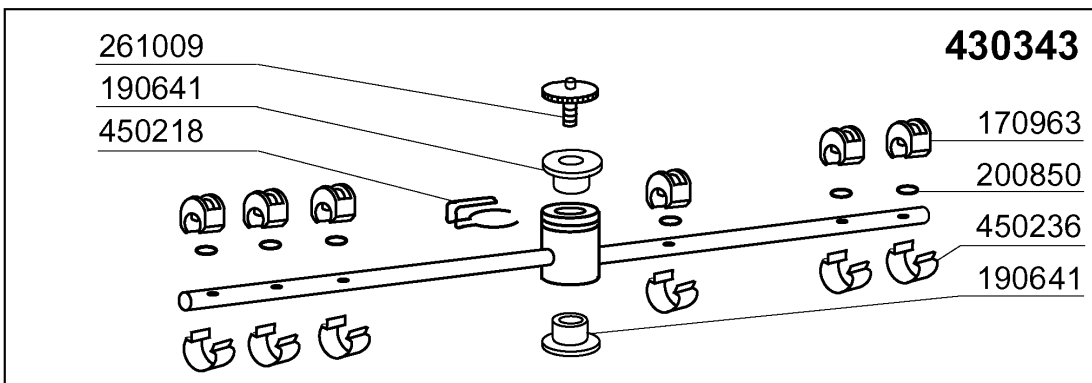
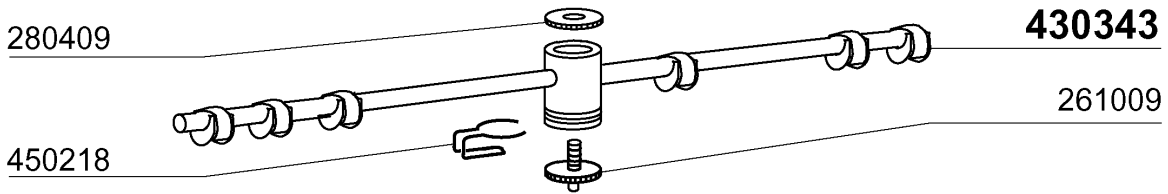
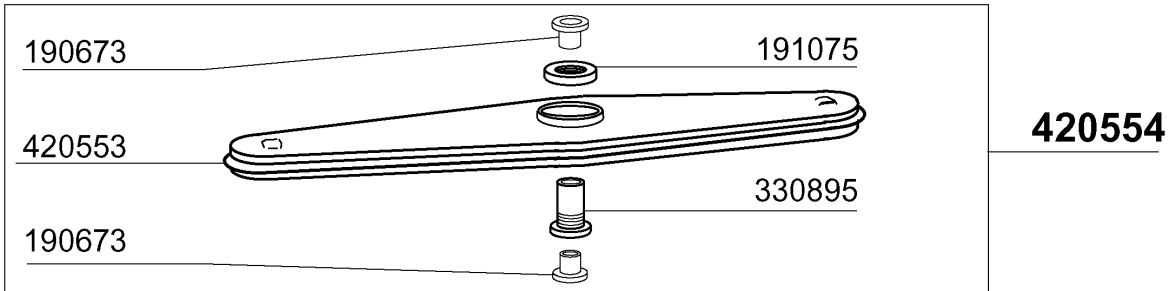
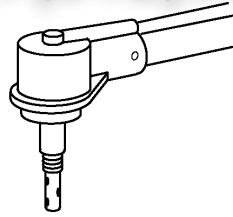

10 - 2002 S.A.G. 01

Зип Общепит

6 - Wash arm

vsezip.ru

CODE	DESCRIPTION
170963	RINSE JET X FOR
190641	BUSH FOR C95-155-105 RINSE ARM
190663	BUSH
190673	BUSH
191075	RETAIN.LOCK
200850	O-RING
261009	RETAIN.SCREW FOR WASH-RINSE AR
280409	RETAIN.LOCK NUT CENTR.CROSS C1
330895	WASH ARM CENTER
420553	S/STEEL WASH ARM - 420572R
420554	WASH ARM (420572R)
430343	RINSE ARM LC700/900/1200
450218	SPRING F.RINSE ARM RETAIN.SCRE
450236	SPRING FOR WASHER 170963

Зип Общепит

7 - Wash arm

vsezip.ru

+7(812)987-08-81

* dalla matricola
a partir de la matr.
from serial no.
ab Seriennr.
despues la matr.
01 - 2003

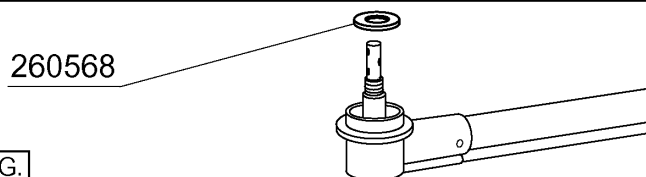
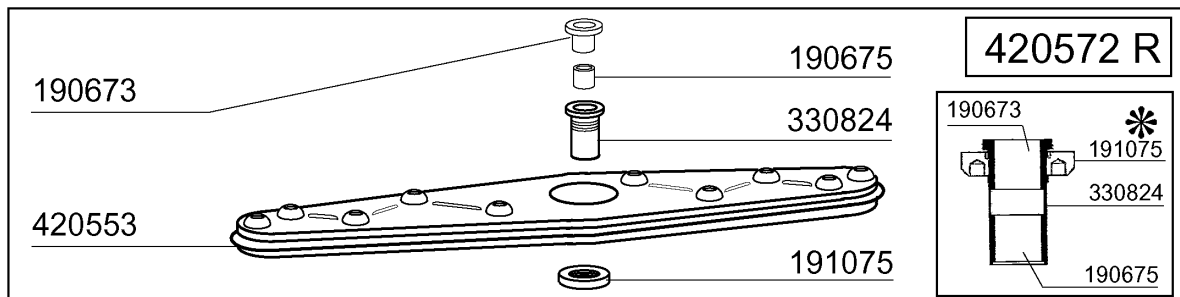
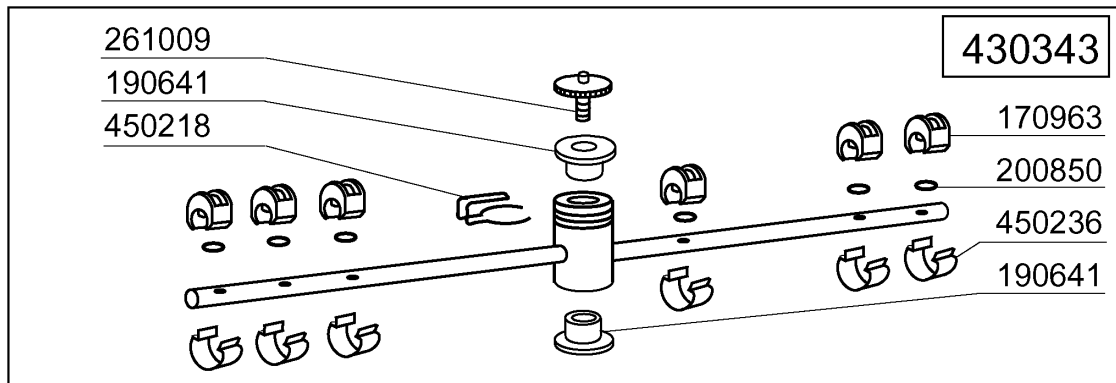
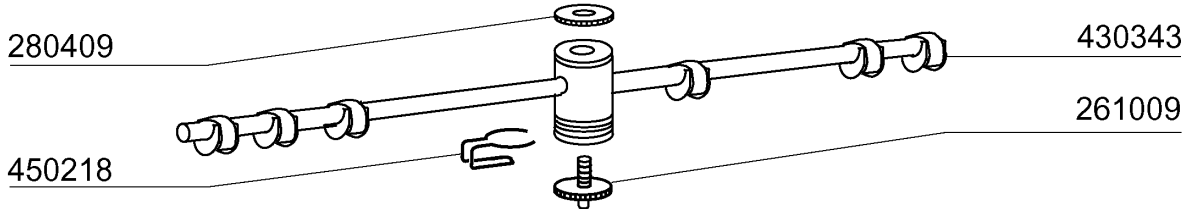
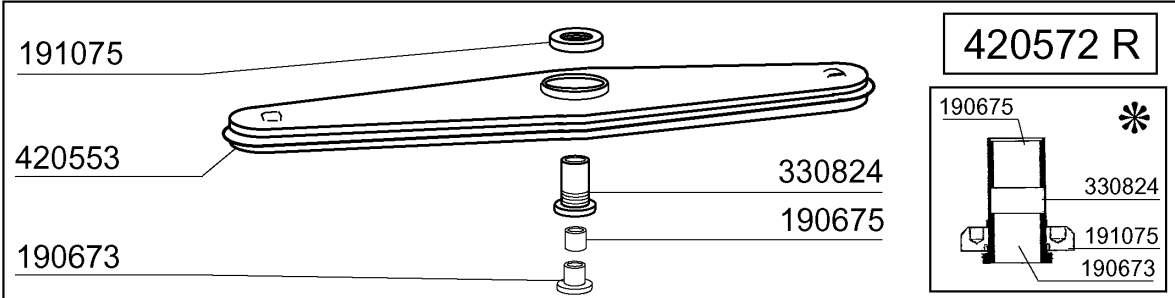
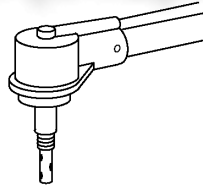

07 - 2003 S.A.G.

Зип Общепит

7 - Wash arm

vsezip.ru

CODE	DESCRIPTION
170963	RINSE JET X FOR
190641	BUSH FOR C95-155-105 RINSE ARM
190673	BUSH
190675	BUSH
191075	RETAIN.LOCK
200850	O-RING
260568	S/S FLAT WASHER D.28X21X1
261009	RETAIN.SCREW FOR WASH-RINSE AR
280409	RETAIN.LOCK NUT CENTR.CROSS C1
330824	WASH ARM CENTER (STAINL.)
420553	S/STEEL WASH ARM - 420572R
420572R	WASH ARM LC
430343	RINSE ARM LC700/900/1200
450218	SPRING F.RINSE ARM RETAIN.SCRE
450236	SPRING FOR WASHER 170963

Зип Общепит

8 - Rinse assembly

vsezip.ru

+7(812)987-08-81

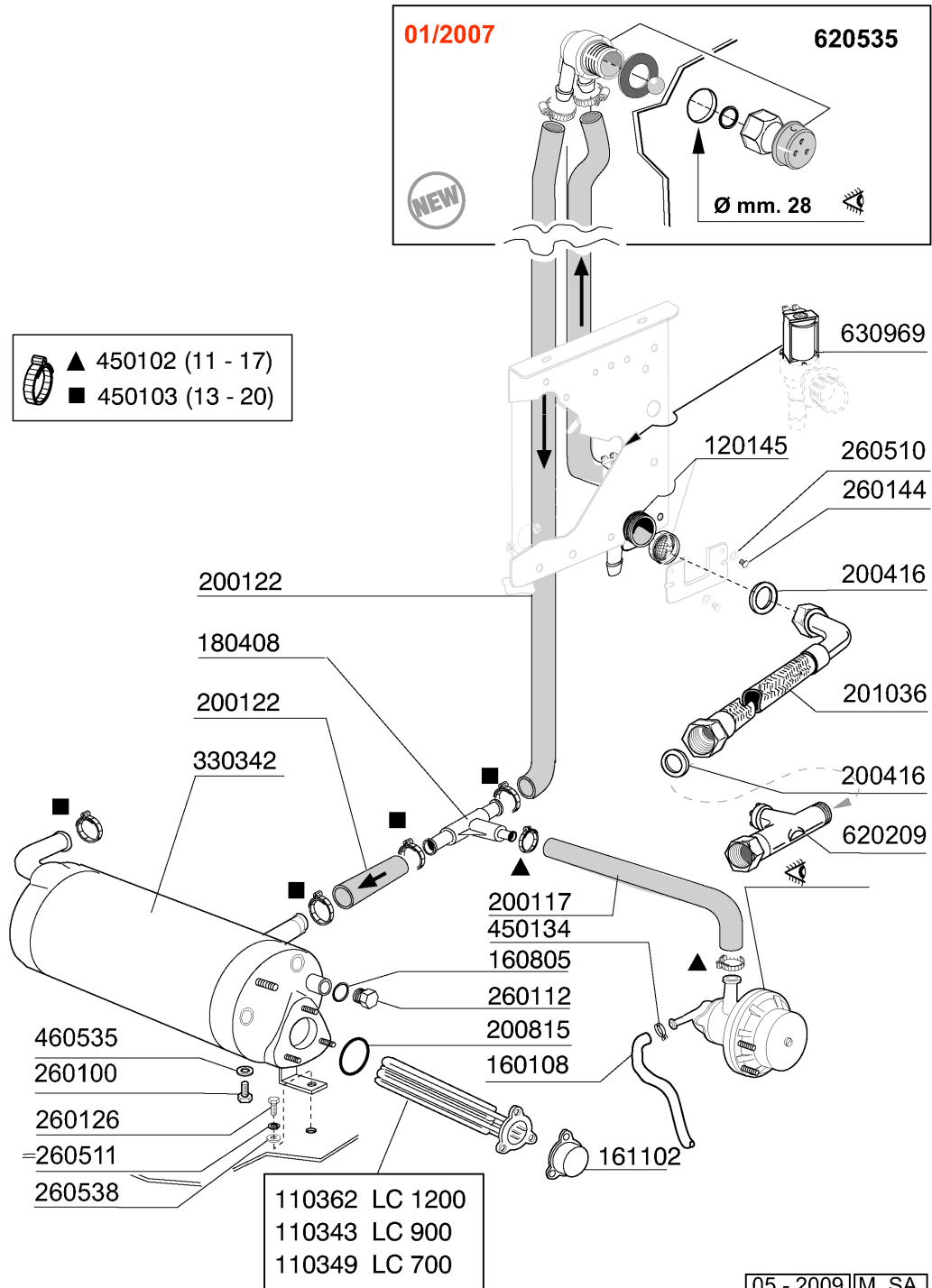

Зип Общепит

8 - Rinse assembly

vsezip.ru

CODE	DESCRIPTION
110343	HEAT.ELEM. 8000W 220/380V
110349	HEAT.ELEMENT 6000W 230/400V
110362	HEAT.ELEMENT 9000W 220/380V
120145	SOLENOID VALVE 12 LT 1 WAY
160108	INJECT.INLET HOSE D.8X5
160805	GASKET D.8
161102	ELEMENT COVER MOPL.
180408	TEE-NIPPLE F.INJECT.W/CENTR.RE
200117	RUBBER HOSE 7X16
200122	HOSE 11X19
200416	GASKET D. 3/4"
200815	O-RING F. HEAT.ELEM.
201036	INLET HOSE 2 MT
260100	SCREW TE 6X8 INOX
260112	STAINLESS STEEL TE-SCREW 8X16
260126	SCREW TE 5X12
260144	SCREW TE 4X6
260510	GROWER WASHER D.4
260511	GROWER WASHER D.5
260538	WASHER 18X6X1,5 ST/ST
330342	BOILER C95-C155-C165
450102	CLAMP FE ZN 11-17 H=9
450103	CLAMP FE ZN. 13-20 H=9
450134	ELASTIC HOSE CLIP D.9,3/8,8
460535	GASKET FOR BOILER PLUG BHC
620209	INLET WATER FILTER
620535	VACUUM BREAKER
630969	COIL S4216 220/50HZ

Зип Общепит

9 - Thermostat/solenoid valve group

vsezip.ru

+7(812)987-08-81

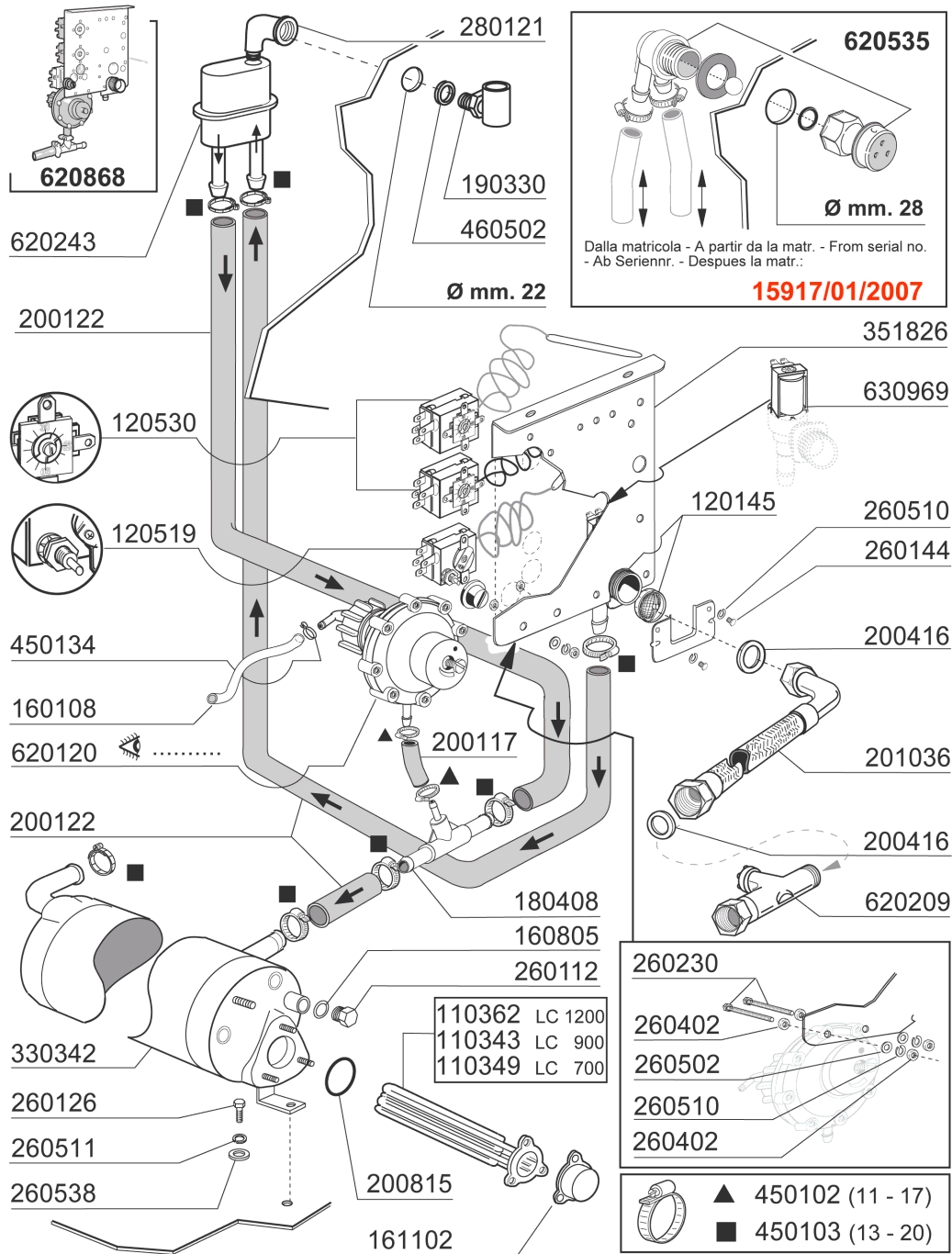

02 - 2007 | S. AG.

Зип Общепит

9 - Thermostat/solenoid valve group

vsezip.ru

CODE	DESCRIPTION
110343	HEAT.ELEM. 8000W 220/380V
110349	HEAT.ELEMENT 6000W 230/400V
110362	HEAT.ELEMENT 9000W 220/380V
120145	SOLENOID VALVE 12 LT 1 WAY
120519	SECURITY THERMOSTAT 95-125Ø
120530	THERMOSTAT 0-90Ø
160108	INJECT.INLET HOSE D.8X5
160805	GASKET D.8
161102	ELEMENT COVER MOPL.
180408	TEE-NIPPLE F.INJECT.W/CENTR.RE
190330	TEE FOR VAACUM BREAKER
200117	RUBBER HOSE 7X16
200122	HOSE 11X19
200416	GASKET D. 3/4"
200815	O-RING F. HEAT.ELEM.
201036	INLET HOSE 2 MT
260112	STAINLESS STEEL TE-SCREW 8X16
260126	SCREW TE 5X12
260144	SCREW TE 4X6
260230	SCREW TCP 4X40
260402	STAINLESS STEEL NUT D4 UNI 55
260502	S/S FLAT WASHER D.4
260510	GROWER WASHER D.4
260511	GROWER WASHER D.5
260538	WASHER 18X6X1,5 ST/ST
280121	ELL FOR VAACUM BREAKER
330342	BOILER C95-C155-C165
351826	BRACKET
450102	CLAMP FE ZN 11-17 H=9
450103	CLAMP FE ZN. 13-20 H=9
450134	ELASTIC HOSE CLIP D.9,3/8,8
460502	GASKET 30X21X2
620120	RINSE AID INJECTOR
620209	INLET WATER FILTER
620243	VACUUM BREAKER (WITHOUT KIT)
620535	VACUUM BREAKER
620868	-ASSIEME COMPONENTI LC
630969	COIL S4216 220/50HZ

Зип Общепит

10 - Thermostat/solenoid valve group

vsezip.ru

+7(812)987-08-81

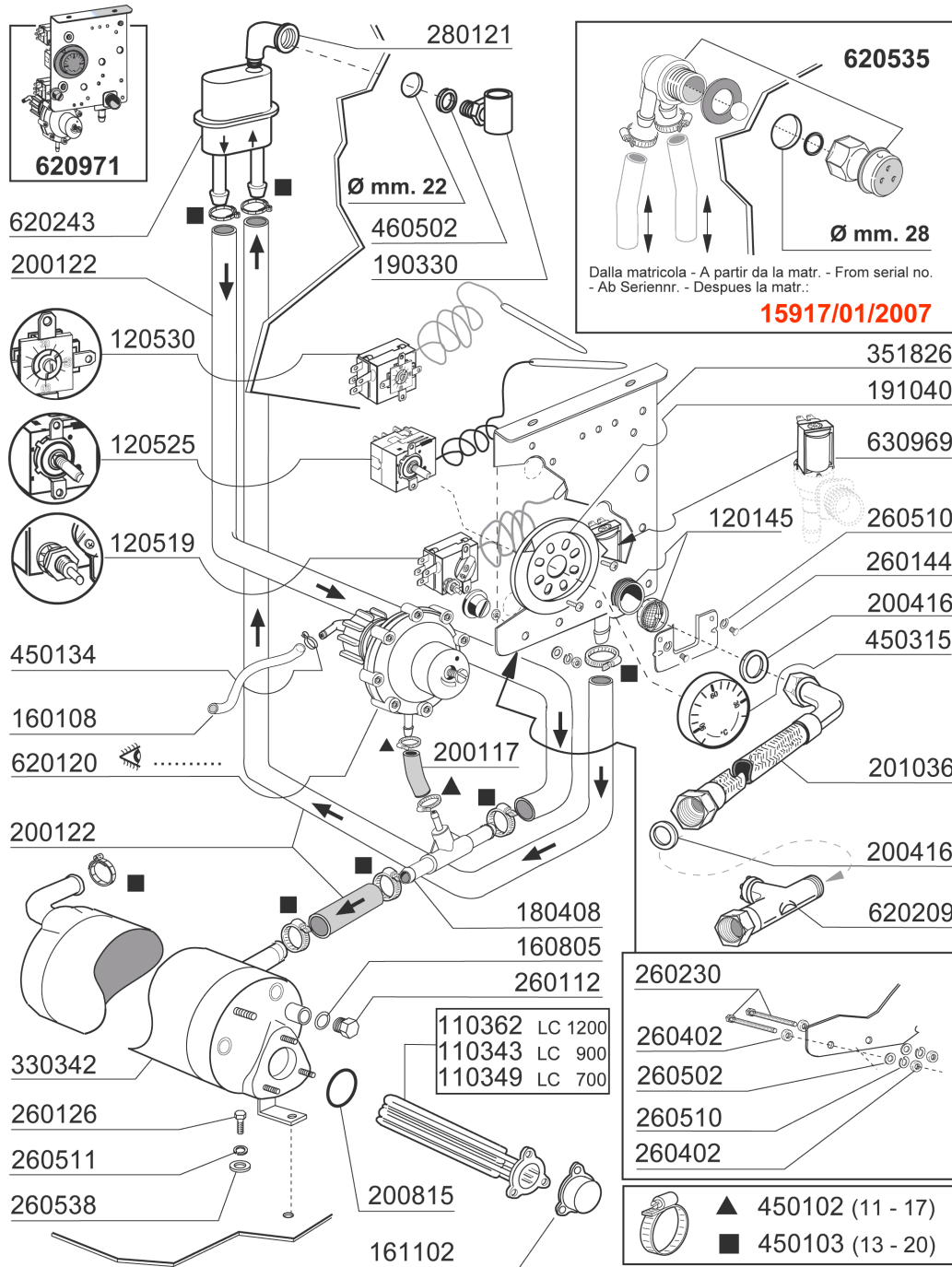

02 - 2007 | S. AG.

Зип Ощепит

10 - Thermostat/solenoid valve group

vsezip.ru

CODE	DESCRIPTION
110343	HEAT.ELEM. 8000W 220/380V
110349	HEAT.ELEMENT 6000W 230/400V
110362	HEAT.ELEMENT 9000W 220/380V
120145	SOLENOID VALVE 12 LT 1 WAY
120519	SECURITY THERMOSTAT 95-125Ø
120525	BOOSTER THERMOSTAT 2 TEMPERAT.
120530	THERMOSTAT 0-90Ø
160108	INJECT.INLET HOSE D.8X5
160805	GASKET D.8
161102	ELEMENT COVER MOPL.
180408	TEE-NIPPLE F.INJECT.W/CENTR.RE
190330	TEE FOR VAACUM BREAKER
191040	FRAME F.THERMOSTAT KNOB
200117	RUBBER HOSE 7X16
200122	HOSE 11X19
200416	GASKET D. 3/4"
200815	O-RING F. HEAT.ELEM.
201036	INLET HOSE 2 MT
260112	STAINLESS STEEL TE-SCREW 8X16
260126	SCREW TE 5X12
260144	SCREW TE 4X6
260230	SCREW TCP 4X40
260402	STAINLESS STEEL NUT D4 UNI 55
260502	S/S FLAT WASHER D.4
260510	GROWER WASHER D.4
260511	GROWER WASHER D.5
260538	WASHER 18X6X1,5 ST/ST
280121	ELL FOR VAACUM BREAKER
330342	BOILER C95-C155-C165
351826	BRACKET
450102	CLAMP FE ZN 11-17 H=9
450103	CLAMP FE ZN. 13-20 H=9
450134	ELASTIC HOSE CLIP D.9,3/8,8
450315	KNOB F. THERMOSTAT 90Ø
460502	GASKET 30X21X2
620120	RINSE AID INJECTOR
620209	INLET WATER FILTER
620243	VACUUM BREAKER (WITHOUT KIT)
620535	VACUUM BREAKER
620971	-ASSIEME COMPONENTI LC 2004
630969	COIL S4216 220/50HZ

Зип Общепит

11 - Wash pump

vsezip.ru

+7(812)987-08-81

630330
630252
630411
630501
632501 50 HZ
632502 60 HZ

630254

631202
16 µF

LC 700

630138

100801
220/240 V
50 Hz - HP 1
Kw 0,75 (5223)

630306
630252
630411
630501
631653 50 HZ
631654 60 HZ

630253

LC 900

630138

100797
230/400 V
50Hz - HP 1.5
Kw 1,1 (5233)

630306
630252
630411
630501
631618 50 HZ
631647 60 HZ

630253

LC 1200

630138

100795
230/400 V
50 Hz - HP 2
Kw 1,5 (5234)

12 - 2002 | S. AG. 01

Зип Общепит
11 - Wash pump
vsezip.ru

CODE	DESCRIPTION
100795	PUMP 2HP 380/3/50HZ
100797	PUMP HP 1,5 350/3/50
100801	PUMP 1HP 230/1
630138	VOLUTE FOR PUMP LC
630252	BACK PLATE PUMP LC
630253	FAN HOUSING FOR PUMP 100797
630254	FAN HOUSING FOR PUMP 100801
630306	PUMP FAN IMPELLOR FI HP.2-3
630330	PUMP 100801 FAN IMPELLOR
630411	O-RING PUMP FI HP 2-2,7
630501	SEAL FOR PUMP HP 2-3-3,2
631202	CONDENSER 16 MF 450V
631618	IMPELLER PUMP F HP2-D.116,5
631647	IMPELLER D.100-60HZ-1204/5
631653	PUMP IMPELLER 1,5 HP 50HZ 1241
631654	PUMP IMPELLER 1,5HP 50HZ 1241
632501	PUMP IMPELLER 1HP 50HZ-5223
632502	PUMP IMPELLER 1HP 60HZ-5223

Зип Общепит

12 - Control panel

vsezip.ru

+7(812)987-08-81

463163 (LC 700)
463164 (LC 900)
463165 (LC 1200)

112833

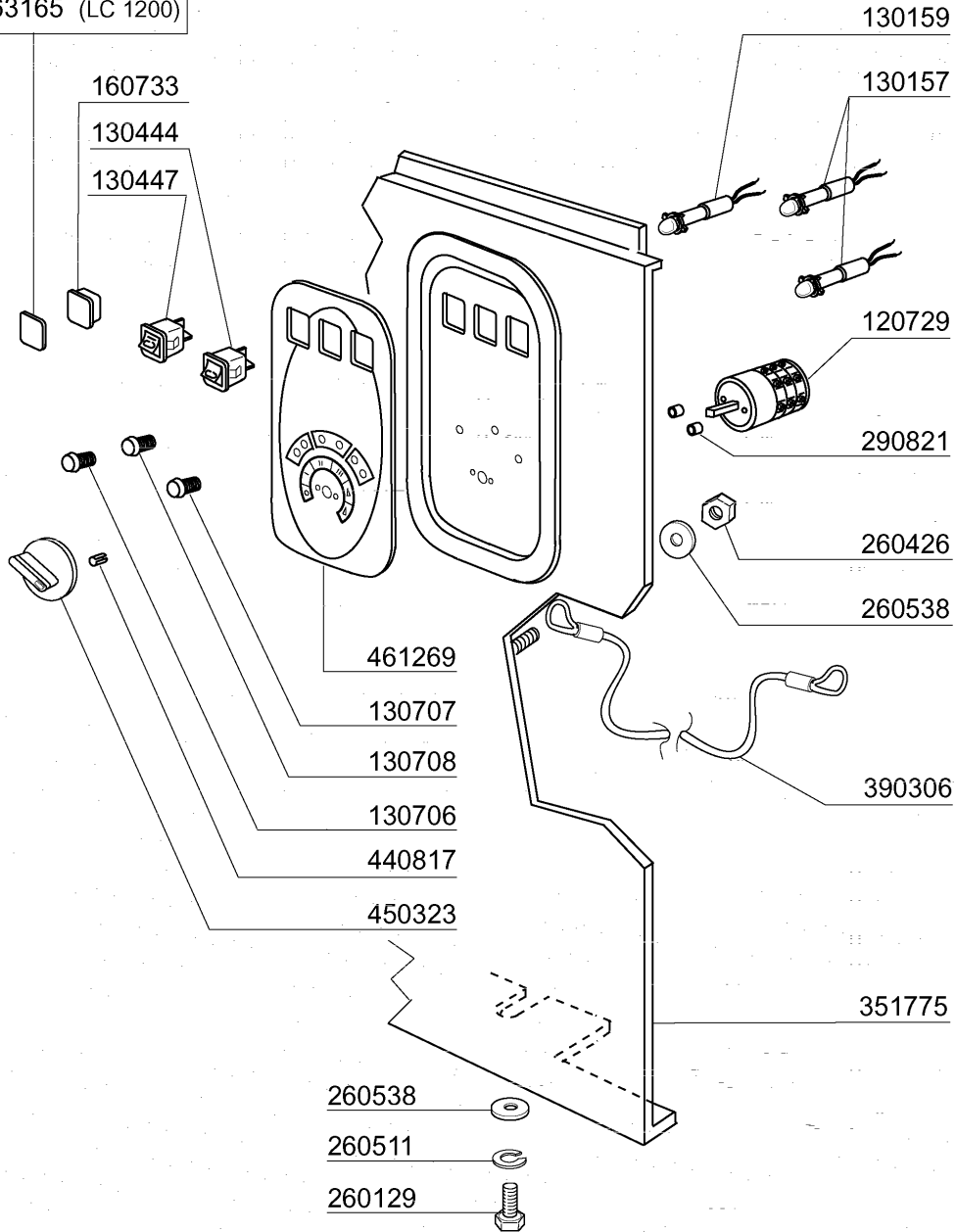

05 - 2004 | S. AG.

Зип Общепит

12 - Control panel

vsezip.ru

CODE	DESCRIPTION
112833	CONTROL PANEL
120729	EIGHT-POLE SWITCH 16.1 5 POS.
130157	GREEN LED FOR BR-BC-C-SERIES -
130159	ORANGE LED FOR C-SERIES - 220V
130444	SWITCH "START CYCLE" F
130447	CYCLE START SELECTOR FOR C-SER
130706	ORANGE LENS COVERS (C-SERIES)
130707	TRANSPARENT LENS COVERS (C-SER
130708	GREEN LENS COVERS (C-SERIES)
160733	BLANK PLATES
260129	SCREW TE M 5X20
260426	DADI ESAG.CIECHI INOX "M6"
260511	GROWER WASHER D.5
260538	WASHER 18X6X1,5 ST/ST
290821	DISTANCE PIECE FOR SWITCH
351775	FRONT PANEL
390306	CABLE
440817	SNAP RING LSCB/1853/17/00
450323	KNOB FOR BC-BR-C95-C155
461269	PLATE LC
463163	LC700 PLATE
463164	LC900 PLATE
463165	LC1200 PLATE

Зип Общепит

13 - Control panel

vsezip.ru

+7(812)987-08-81

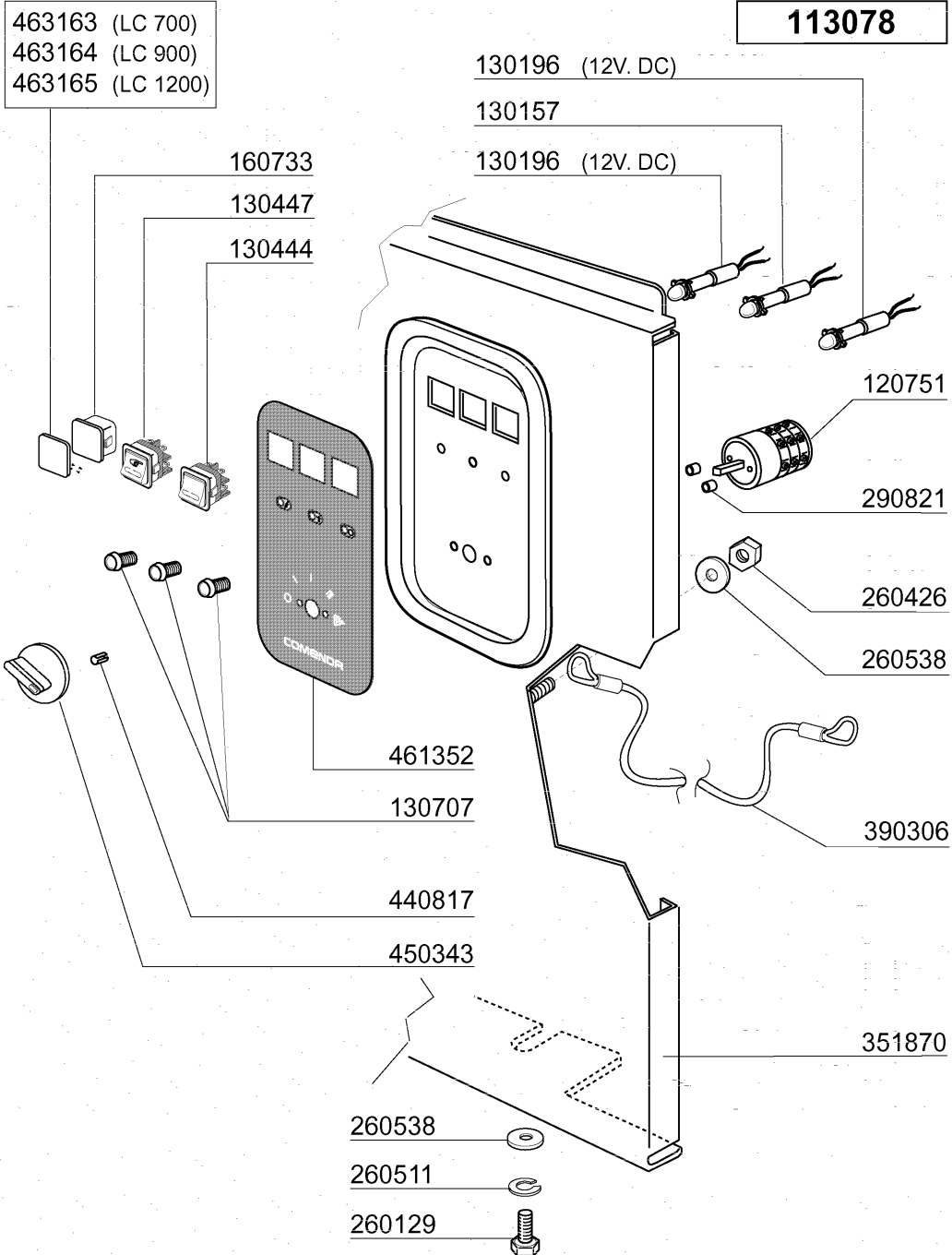

04-2005 | S. AG.

Зип Общепит

13 - Control panel

vsezip.ru

CODE	DESCRIPTION
113078	PANN.COM.LC2004
120751	4 POLE SWITCH 16A
130157	GREEN LED FOR BR-BC-C-SERIES -
130196	GREEN LAMP
130444	SWITCH "START CYCLE" F
130447	CYCLE START SELECTOR FOR C-SER
130707	TRANSPARENT LENS COVERS (C-SER
160733	BLANK PLATES
260129	SCREW TE M 5X20
260426	DADI ESAG.CIECHI INOX "M6"
260511	GROWER WASHER D.5
260538	WASHER 18X6X1,5 ST/ST
290821	DISTANCE PIECE FOR SWITCH
351870	FRONT PANEL LC2004
390306	CABLE
440817	SNAP RING LSCB/1853/17/00
450343	BLUE SWITCH
461352	LC2004 PLATE
463163	LC700 PLATE
463164	LC900 PLATE
463165	LC1200 PLATE

Зип Общепит

14 - Control box

vsezip.ru

+7(812)987-08-81

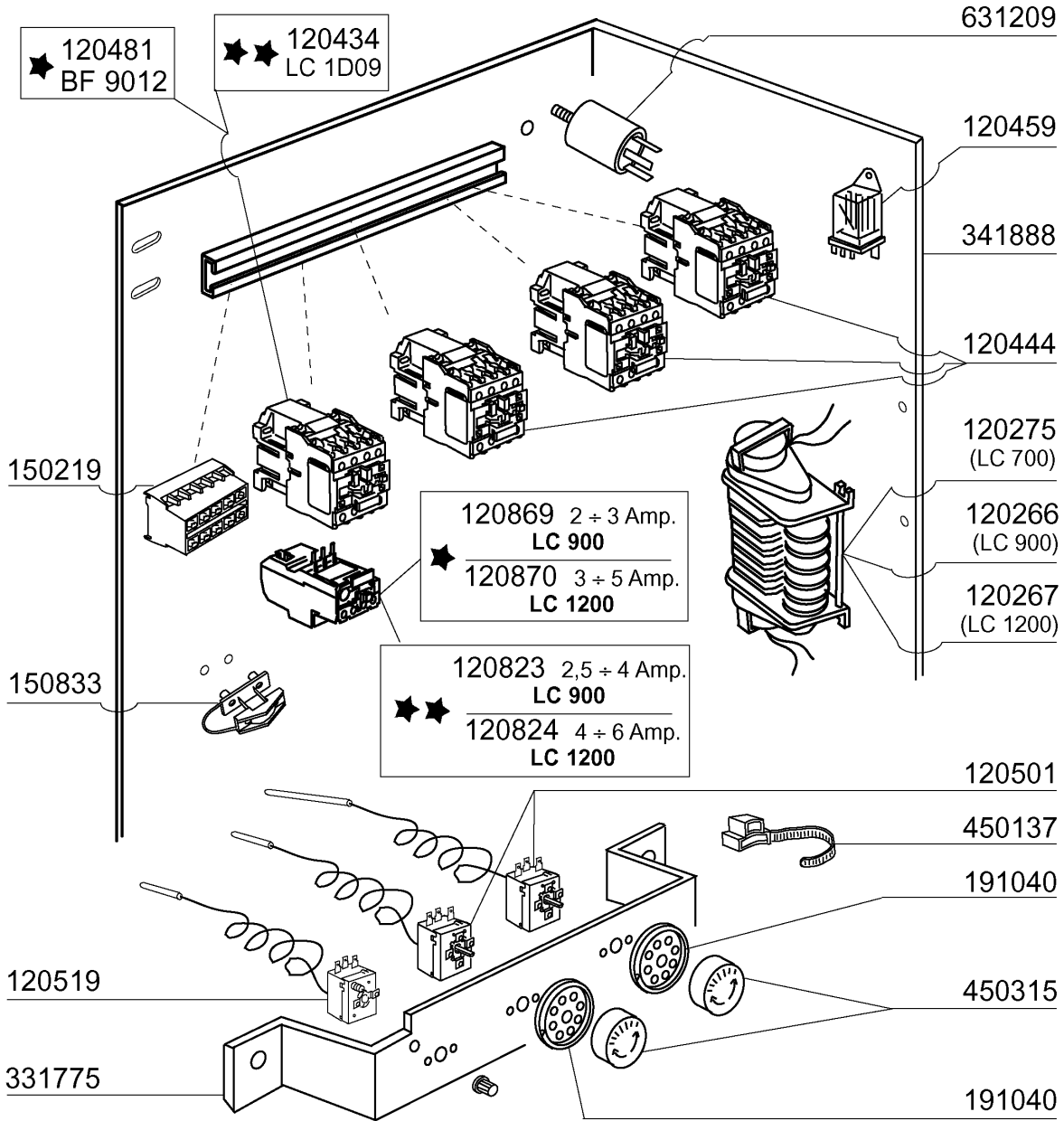

LC 700

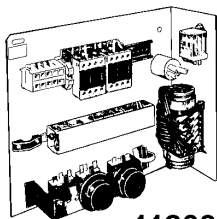

112839

LC 900

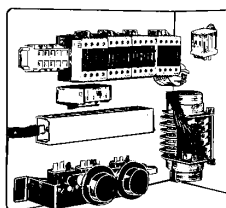

112837

LC 1200

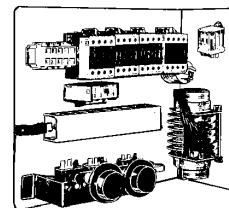

112835

10 - 2002 | S.A.G.

Зип Общепит

14 - Control box

vsezip.ru

CODE	DESCRIPTION
112835	WIRING
112837	WIRING
112839	WIRING
120266	TIMER 6 CAMS 75/120/180"
120267	TIMER 6 CAMS 60/85/120"
120275	TIMER
120434	CONTACTOR 9A 220V 50HZ
120444	CONTACTOR 9A 220V 50HZ
120459	AUXIL.RELE 16A 220V
120481	CONTACTOR 9A-230V 50/60HZ
120501	THERMOSTAT 30/90°C
120519	SECURITY THERMOSTAT 95-125°C
120823	OVERLOAD RELAY 2.5/4 A
120824	OVERLOAD RELAY 4/6 A
120869	OVERLOAD RELAY 2/3,3
120870	OVERLOAD RELAY 3/5
150219	TERMINAL BLOCK 5P MMQ165VD26
150833	CABLE HOLDER BC/BR
191040	FRAME F.THERMOSTAT KNOB
331775	BRACKET 3 THERMOSTATS
341888	CONTROL BOX SUPPORT
450137	COLLAR CONNECTION WITH BASE 31
450315	KNOB F. THERMOSTAT 90°C
631209	ANTI-NOISE FILTER

Зип Общепит

15 - Control box

vsezip.ru

+7(812)987-08-81

113080 (LC 700)

113081 (LC 900)

113082 (LC 1200)

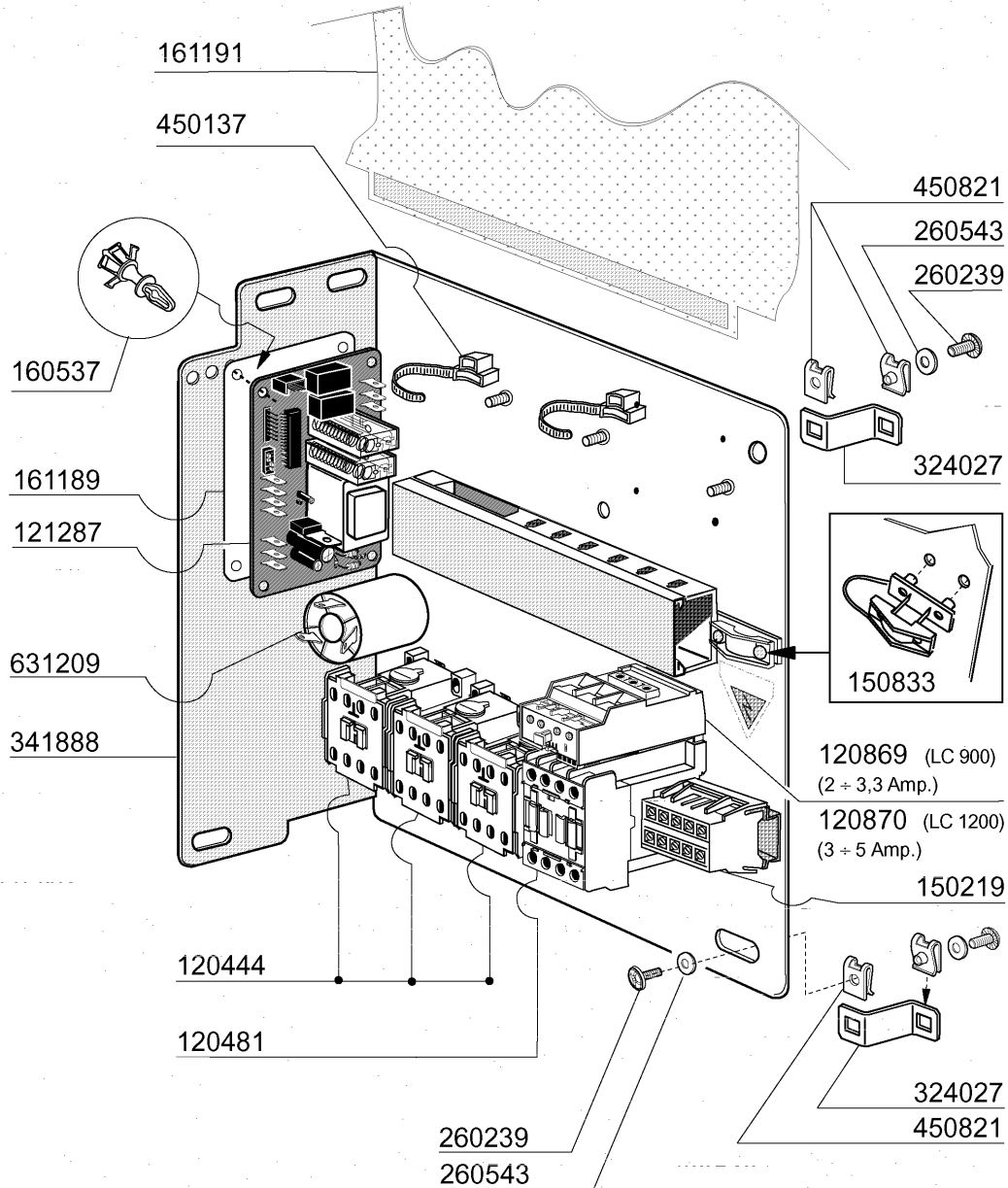

04 - 2005 | S. AG.

Зип Общепит

15 - Control box

vsezip.ru

CODE	DESCRIPTION
113080	-IMP.ELET.LC700 04 (11335.0)
113081	IMP.EL.LC900
113082	IMP.EL.C1301M 04
120444	CONTACTOR 9A 220V 50HZ
120481	CONTACTOR 9A-230V 50/60HZ
120869	OVERLOAD RELAY 2/3,3
120870	OVERLOAD RELAY 3/5
121287	ELECTRONIC TIMER
150219	TERMINAL BLOCK 5P MMQ165VD26
150833	CABLE HOLDER BC/BR
160537	ELECTRONIC CARD SPACER
161189	COVER
161191	CONTROL BOX COVER
260239	SPECIAL S/S TB-SCREWS M6X20
260543	WASHER D.6 ST/ST
324027	SQUADR.FISS.IMP.EL. LC 2001-08
341888	CONTROL BOX SUPPORT
450137	COLLAR CONNECTION WITH BASE 31
450821	SPRING CLIP FASTENER SNU 3634
631209	ANTI-NOISE FILTER

Зип Общепит

16 - Rinse aid injector

vsezip.ru

+7(812)987-08-81

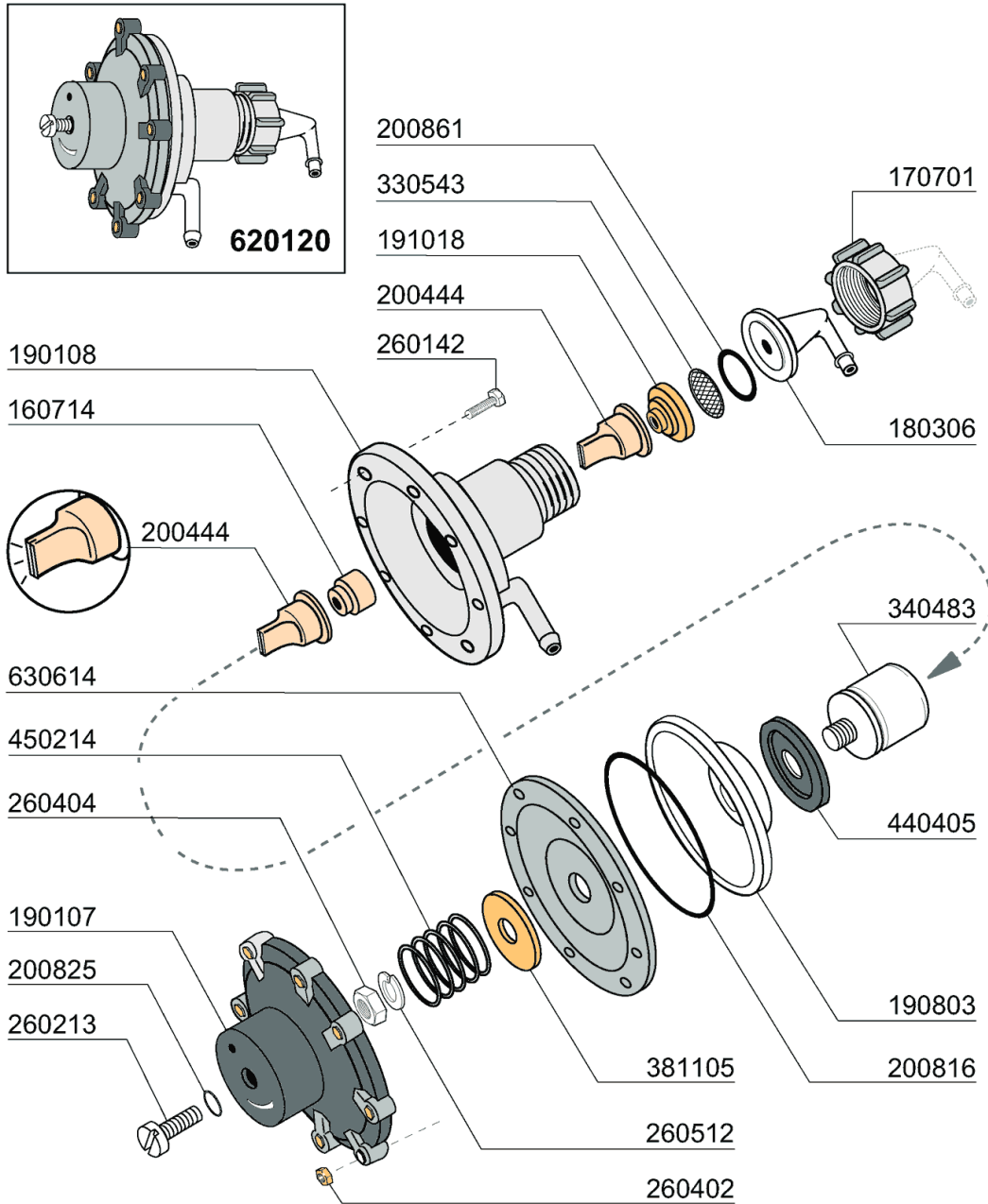

09 - 2007 | S. AG.

Зип Общепит

16 - Rinse aid injector

vsezip.ru

CODE	DESCRIPTION
160714	PLUG FOR RINSE AID INJECTOR MC
170701	LOCK NUT 1/2" F.INJECTOR
180306	NIPPLE F.RINSE AID INJECTOR
190107	COVER FOR RINSE AID DISPENSER
190108	VOLUTE FOR RINSE AID DISPENSER
190803	GASKET SUPPORT RING F.INJECT
191018	FILTER SUPPORT RINSE AID INJEC
200444	SUCTION VALVE RINSE INJECTOR
200816	O-RING 2,5X59,2X64,2 RINSE INJ
200825	O-RING 3X5X11 RINSE INJECTOR
200861	O-RING 14X18X2
260142	SCREW TE 4X16
260213	SCREW TCP 5X25
260402	STAINLESS STEEL NUT D4 UNI 55
260404	STAINLESS STEEL NUTS D6 UNI 55
260512	ST/ST GROWER WASHER D6
330543	FILTER RINSE AID INJECTOR D.17
340483	PISTON FOR RINSE AID DISPENSER
381105	DIAPHRAGME DISC
440405	GASKET FOR RINSE AID INJ.
450214	SPRING RINSE AID INJECTOR
620120	RINSE AID INJECTOR
630614	DIAPHRAGM RINSE INJECTOR

Зип Общепит

17 - DRAIN PUMP

vsezip.ru

+7(812)987-08-81

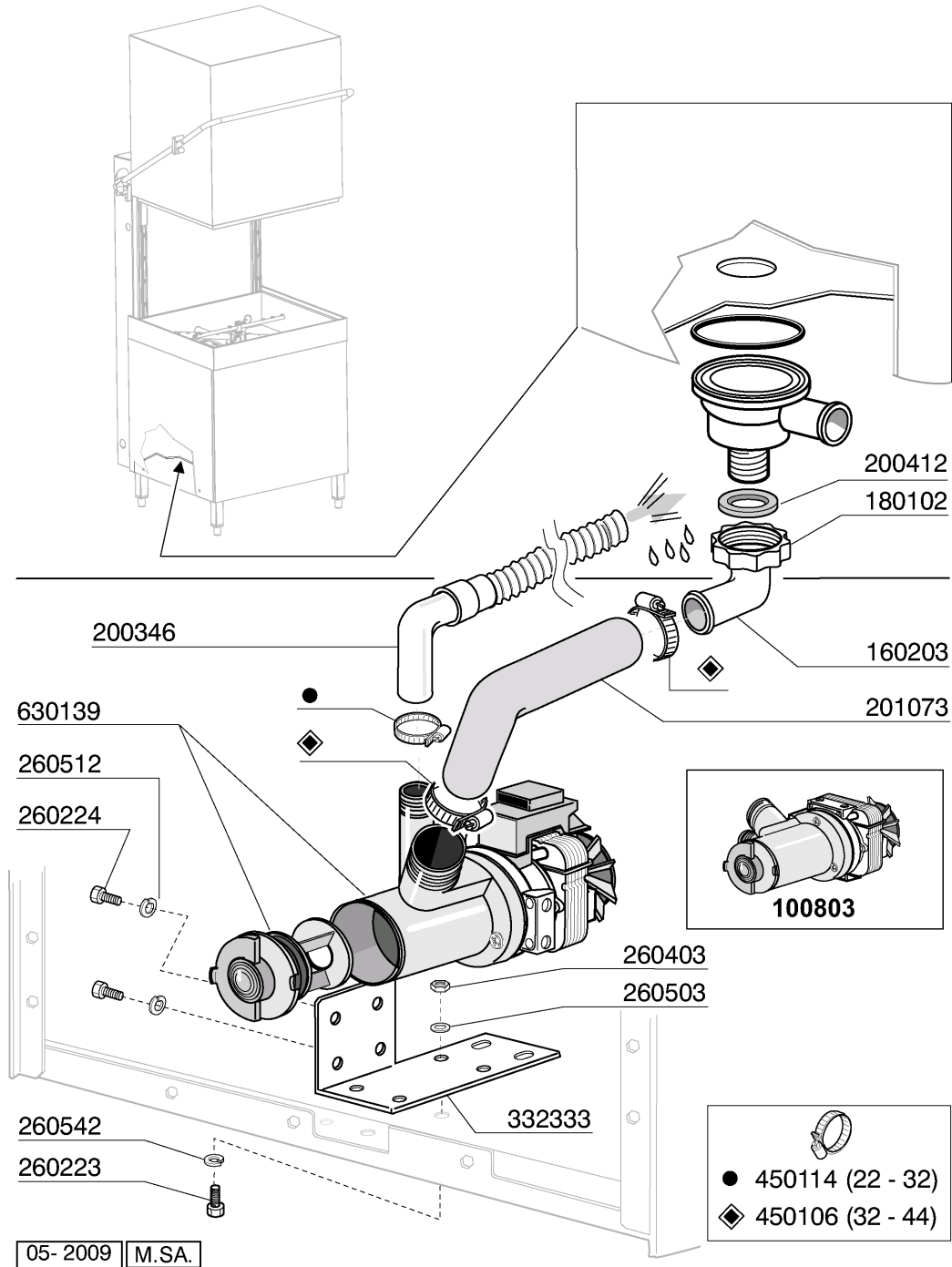

Зип Общепит

17 - DRAIN PUMP

vsezip.ru

CODE	DESCRIPTION
100803	DRAIN PUMP WITH FILTER 220/50
160203	ELBOW 1"1/2 M.S.-F.C. DRAIN
180102	DRAIN PIPE NUT 1"1/2 F45-55
200346	DRAIN HOSE GLASSWASHER
200412	GASKET DRAIN 1 1/2" 45X33X3
201073	INLET HOSE LC/CE DRAIN PUMP
260223	M5X12 MSH/HD SCREW SPECIAL S/S
260224	TB-SCREW 6X15 B23-10-11-12
260403	NUTS D.5
260503	STAINL.STEEL FLAT WASHER D5 UN
260512	ST/ST GROWER WASHER D6
260542	WASHER D.5
332333	BRACKET FOR DRAIN PUMP
450106	CLAMP FE ZN 32-44 H=12,2
450114	CLAMP FE ZN.22-32 H=12,2
630139	DRAIN PUMP VOLUTE WITH FILTER

Зип Общепит

18 - CRC

vsezip.ru

+7(812)987-08-81

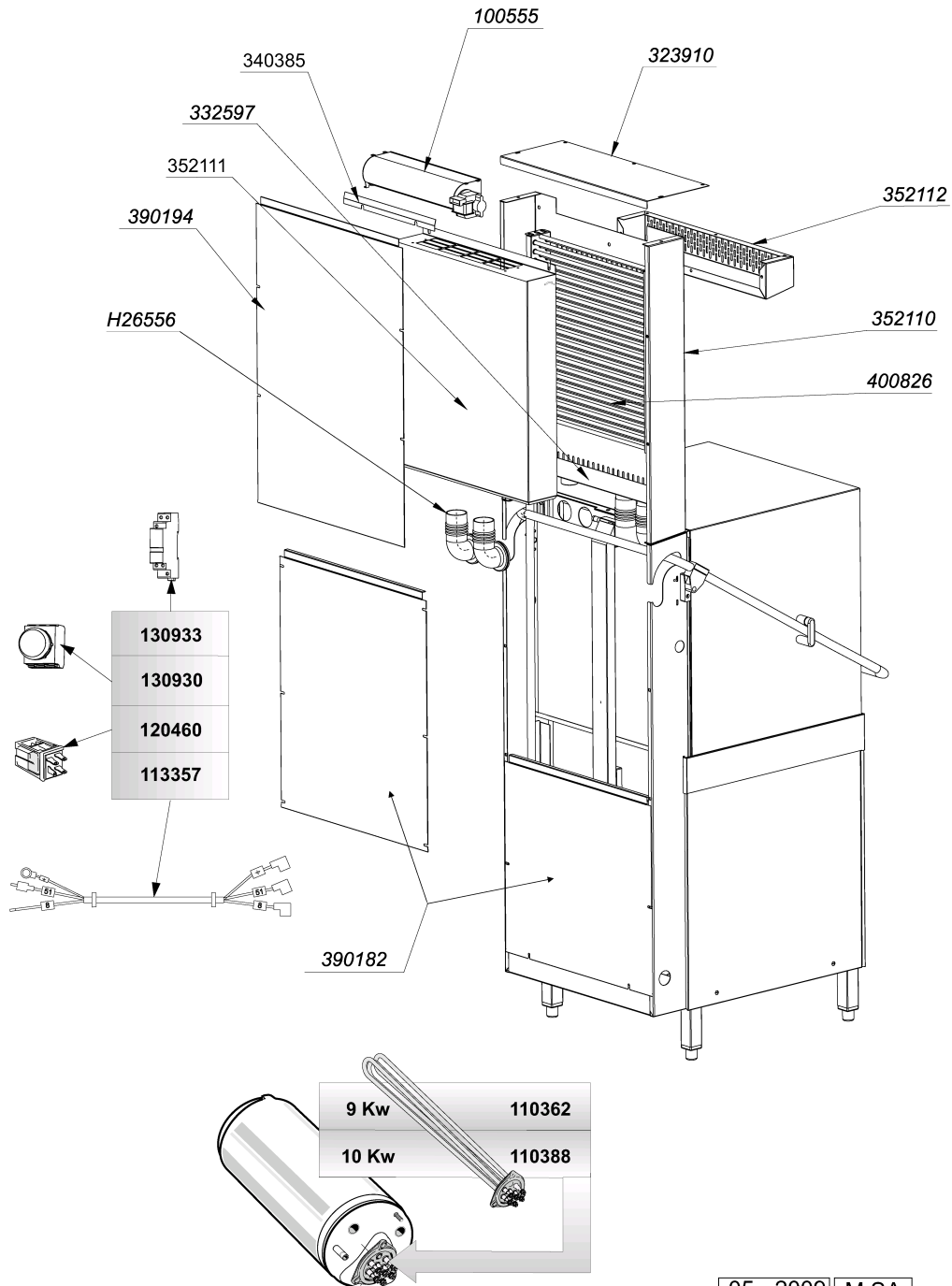

Зип Общепит

18 - CRC

vsezip.ru

CODE	DESCRIPTION
100555	FAN TGA60/1 360-50
110362	HEAT.ELEMENT 9000W 220/380V
110388	HEAT.ELEMENT 10000W 230/400V
113357	CABLE FOR CRC
120460	RELAY 16A 220V
130930	CONTACT ABB 1NO/1NC 180"
130933	SUPPL. CONTACT NO/NC ABB
323910	CRC UPPER COVER
332597	COLLETTORE ASPIRAZ. CRC C2001
340385	PARATIA VENT."POST" CRC C2001
352110	BACK PANEL
352111	BACK PANEL CRC
352112	FRONT COVER CRC
390182	BACK PANEL
390194	BACK PANEL CRC
400826	CRC BATTERY
H26556	HOSE