



C 300

Зип Общепит

LIST OF THE EXPLODED VIEWS

vsezip.ru

+7(812)987-08-81

3rd Version

From s/n.213748 up Today

2nd Version

From s/n.144814 To s/n.213747



SHELL ASSY (2nd/3rd Version)

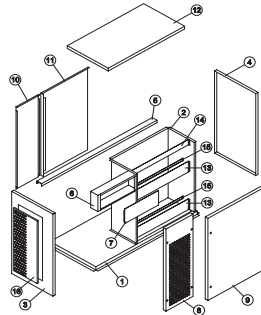

COOLING SYSTEM (2nd/3rd Version)

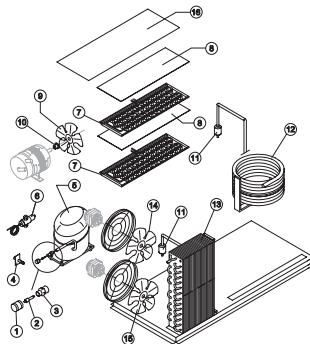

HYDRAULIC CIRCUIT (3rd Version)

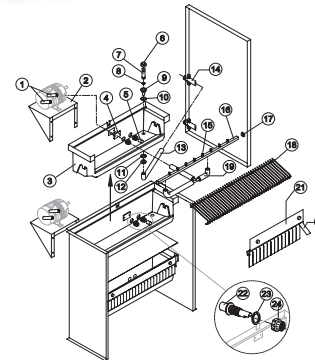

HYDRAULIC CIRCUIT (2nd Version)

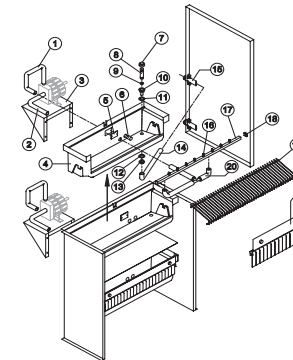

ELECTRIC PARTS (2nd/3rd Version)

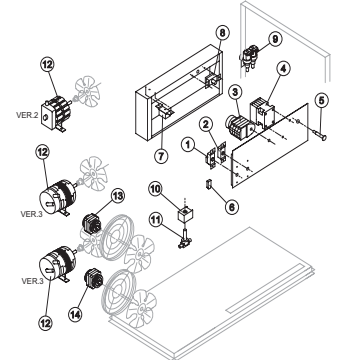

SHELL ASSY

COOLING SYSTEM

HYDRAULIC CIRCUIT

ELECTRIC PARTS

1st Version

Till s/n.144813

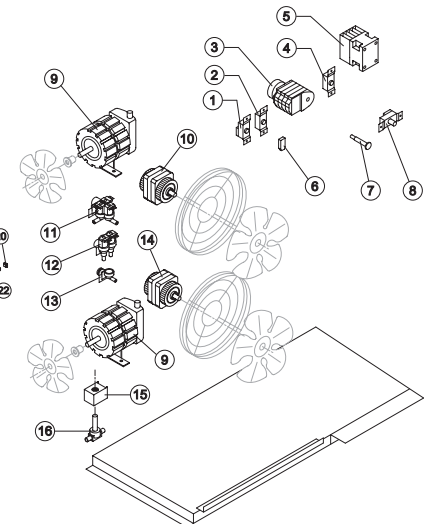
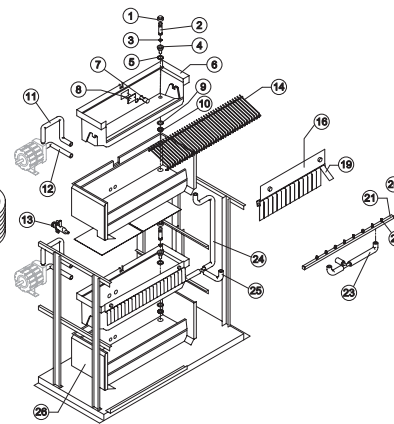
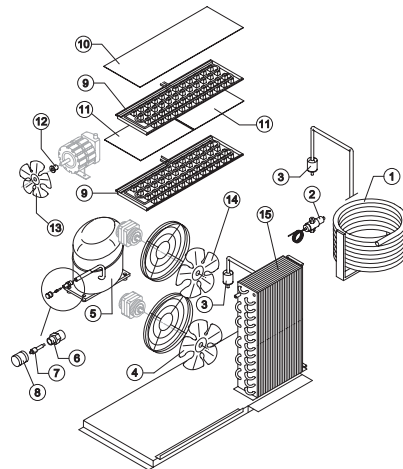
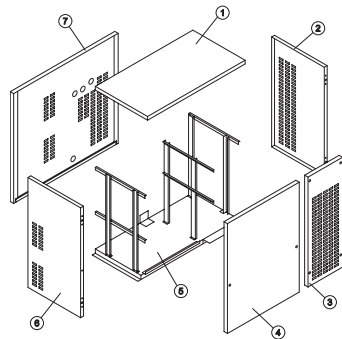

Rev. 3 - 20/10/2003



C 300

Зип Общепит
 3rd Version From s/n.213748 up Today
 2nd Version From s/n.144814 To s/n.213747
 vsezip.ru

SHELL ASSY

+7(812)987-08-81

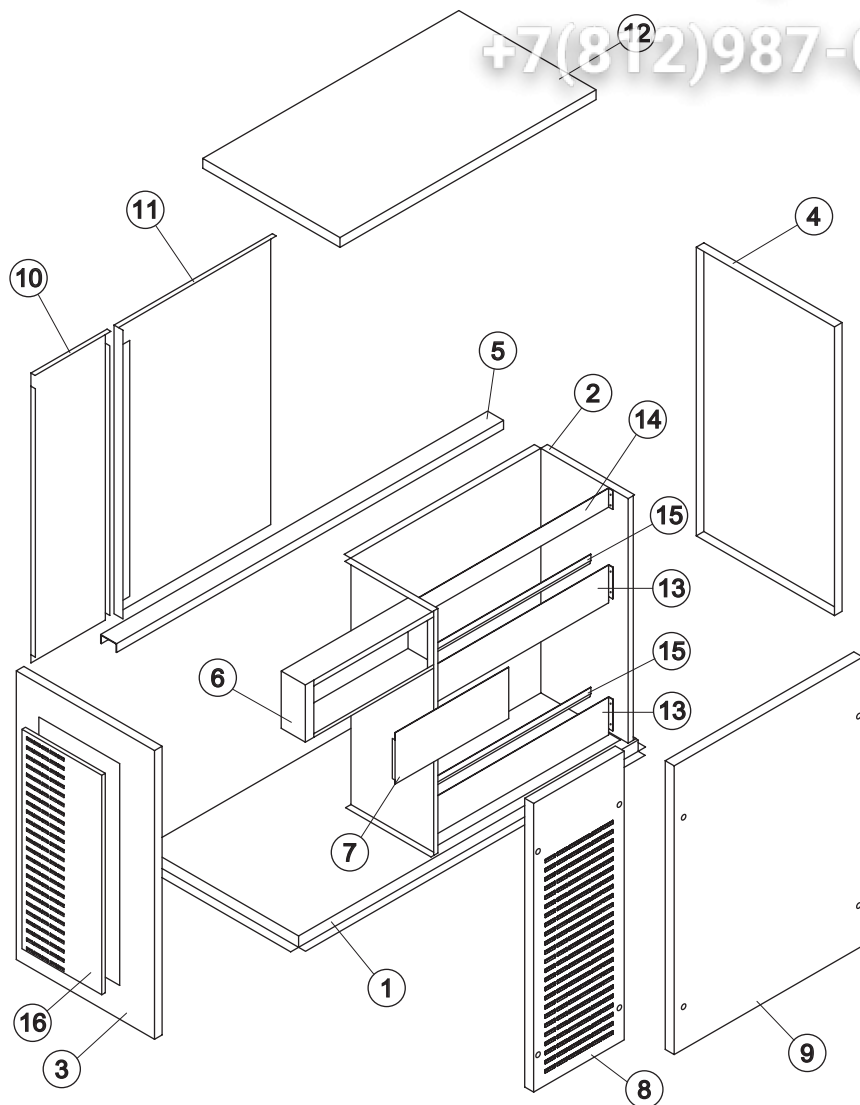

Rev. 3 - 20/10/2003

Ref.	Spare Description	Code
1	Base Plate	21240
2	Evaporator Chamber	Current Version 22889
2	Evaporator Chamber	Till s/n. 213747 22737
3	Left Side	22736
4	Right Side	22735
5	Transom	22838
6	Power Box	22837
7	Electric Parts Plate	21239
8	Front Panel (Group Side)	22741
9	Front Panel (Bin Side)	C22744
10	Back Panel (Group Side)	21288
11	Back Panel (Bin Side)	21241
12	Top Assy	C22738
13	Bulkhead	Current Version 22890
13	Bulkhead	Till s/n. 213747 22739
14	Upper Bulkhead	22809
15	Rim Support of the Inside Bin	22740
16	Left Panel	22810



C 300

Зип Общепит
 3rd Version From s/n.213748 up Today
 2nd Version From s/n.144814 To s/n.213747
 vsezip.ru

+7(812)987-08-81

COOLING SYSTEM

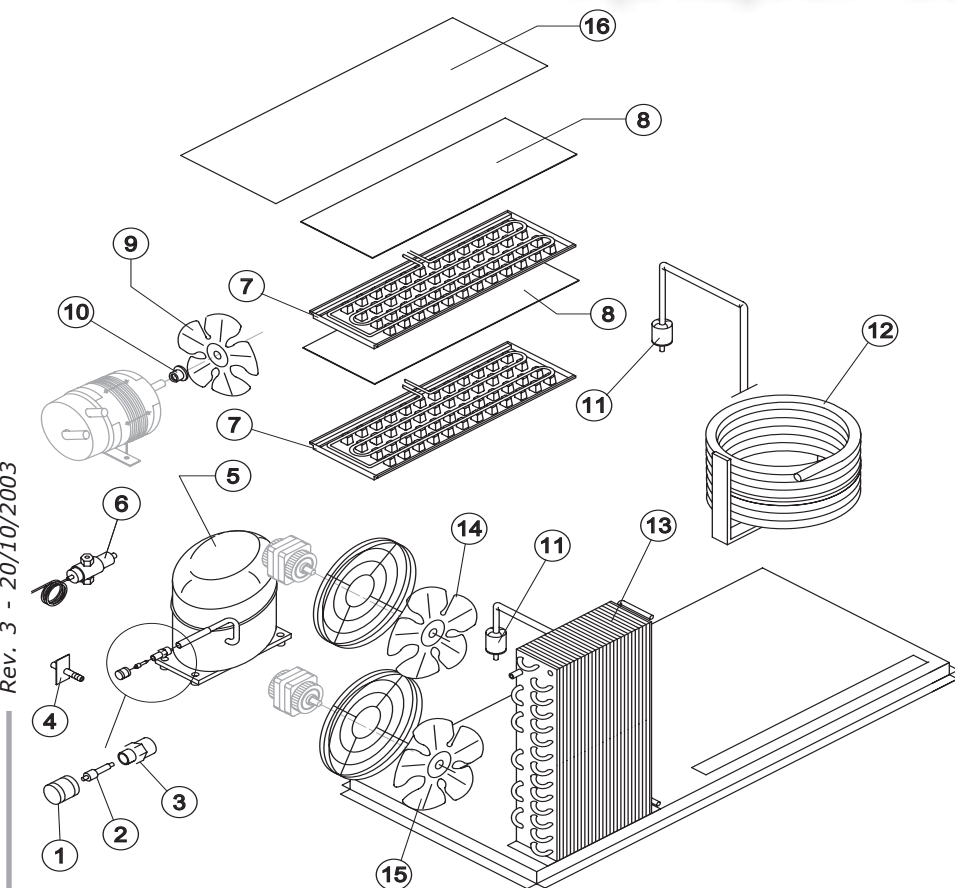

Common Parts

Ref.	Spare Description	Code
1	Vacuum-Charge Valve Plug	14006
2	Vacuum-Charge Valve Device	14005
3	Vacuum-Charge Valve Body	14007
5	Compressor	See Table -
7	Evaporator	See Table -
8	Evaporator Cover	10058
9	Suction Fan	10213
10	Hub for the Fan Fixing	10014
11	Solid Core Drier	14084
16	Upper Evaporator Cover	From s/n. 213748 10439

Parts for Air-Cooled Version Only

Ref.	Spare Description	Code
13	Air Condenser	20406
14	Suction Fan 275 / 34°	20153
15	Suction Fan 254 / 31°	20031

Parts for Water-Cooled Version Only

Ref.	Spare Description	Code
4	Rubber Holder with Plate	C20462
6	Pressure Valve	20149
12	Water Condenser	14285

Ref. 5 - Compressor

Tension	Code
220/240V 50 Hz	23489
220/230V 60 Hz	23527
230V 3 50 Hz	23563
400V 3N 50 Hz	23453
220/230V 3 60 Hz	23563

Ref. 7 - Evaporator

Kind of Cube	Codice
18 g. (Standard)	D10214
33 g. (Big)	D10092
13 g. (Small)	D10126

Rev. 3 - 20/10/2003



C 300

Зип Общепит

3rd Version From s/n.213748 up Today

vsezip.ru

HYDRAULIC CIRCUIT

+7(812)987-08-81

Common Parts

Ref.	Spare Description	Code	
1	Pump Suction/Delivery Pipe	13150	
2	Pump Support Plate	21277	
3	Inner Basin	10440	
4	Slide Keep Plate	10009	
5	Pump Suction Filter	20005	
6	Overflow Cap	10305	
7	Overflow Pipe	10133	
8	OR Gasket for Overflow Pipe	20233	
9	Plastic Nipple Water Outlet	10241	
10	Silicone Gasket	13006	
11	Semirigid Polyethylene Gasket	13007	
12	Bin Discharge Nut	10096	
13	Water Discharge Pipe	13054	
14	Drain Nipple	C10415	
15	Sprayer	D20002	
16	Sprayers Bar Assembly	See Table	-
17	Sprayers Bar Plug		10012
18	Ice Cubes Slide	See Table	-
19	Sprayers Bar Pipe Connection		C13036
20	Flag		10005
21	Flags Support Assy		C22134
22	Fitting of the Pump Suction/Delivery Pipes		10424
23	Gasket for Suction Line/Pump Delivery		13143
24	Fittings Locking Ring		10405

Ref. 16 - Sprayers Bar Ass.

Kind of Cube	Code
18 g. (Standard)	C20144
33 g. (Big)	C20157
13 g. (Small)	C20200

Ref. 18 - Ice Cubes Slide

Kind of Cube	Code
18 g. (Standard)	D12022
33 g. (Big)	D12033
13 g. (Small)	D12040

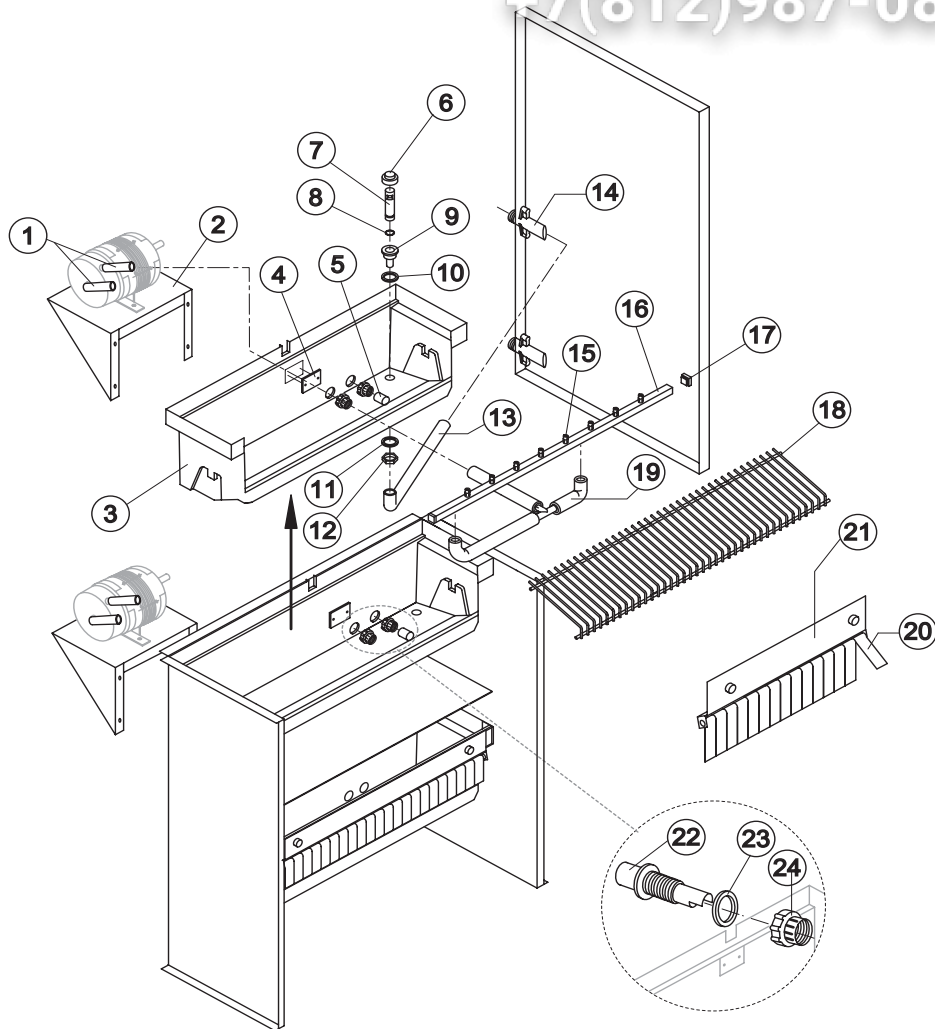

Rev. 3 - 20/10/2003



C 300

Зип Общепит

2nd Version From s/n.144814 To s/n.213747

vsezip.ru

HYDRAULIC CIRCUIT

+7(812)987-08-81

Common Parts

Spare Description		Code	
1	Pump Delivery Pipe	13133	
2	Pump Suction Pipe	13047	
3	Pump Support Plate	21277	
4	Inner Basin	10055	
5	Slide Keep Plate	10009	
6	Pump Suction Filter	20005	
7	Overflow Cap	10305	
8	Overflow Pipe	10133	
9	OR Gasket for Overflow Pipe	20233	
10	Plastic Nipple Water Outlet	10007	
11	Silicone Gasket	13006	
12	Semirigid Polyethylene Gasket	13007	
13	Bin Discharge Nut	10096	
14	Water Discharge Pipe	13067	
15	Drain Nipple	C10415	
16	Sprayer	D20002	
17	Sprayers Bar Assembly	See Table	-
18	Sprayers Bar Plug		10012
19	Ice Cubes Slide	See Table	-
20	Sprayers Bar Pipe Connection		C13036
24	Flag		10005
25	Flags Support Assy		C22134

Ref. 17 - Sprayers Bar Ass.

Kind of Cube	Code
18 g. (Standard)	C20144
33 g. (Big)	C20157
13 g. (Small)	C20200

Ref. 19 - Ice Cubes Slide

Kind of Cube	Code
18 g. (Standard)	D12022
33 g. (Big)	D12033
13 g. (Small)	D12040

Rev. 3 - 20/10/2003

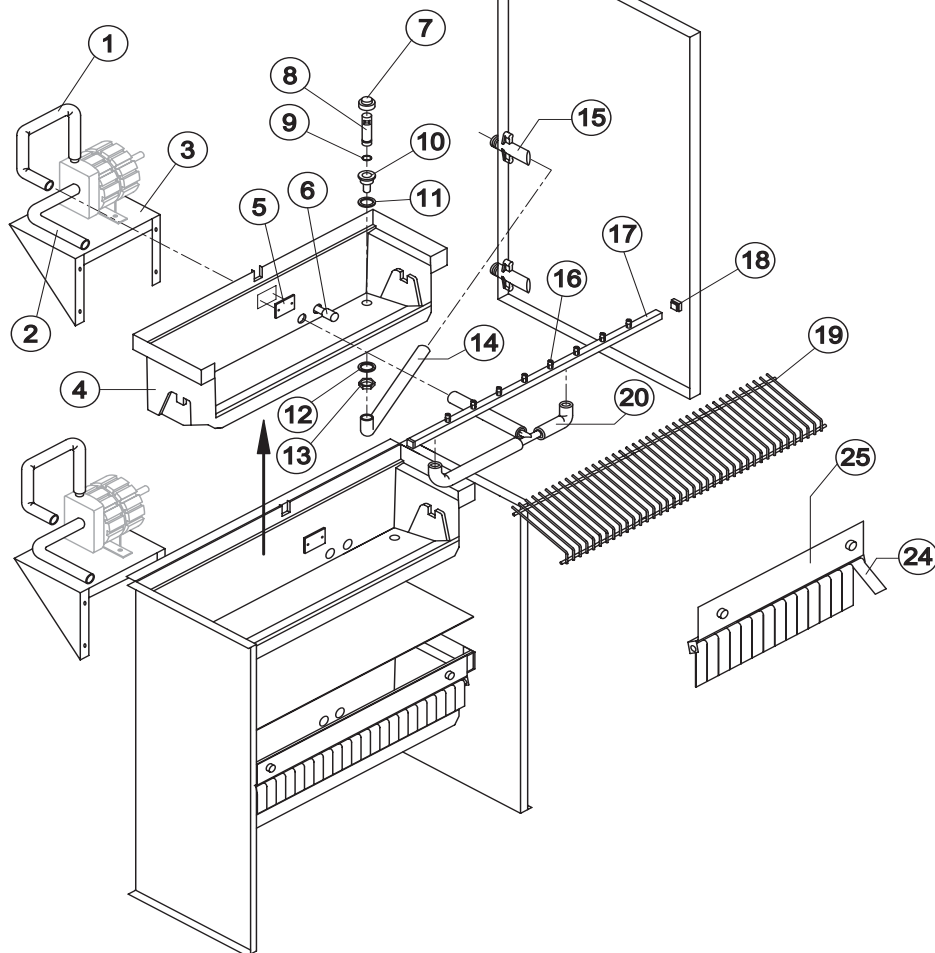



C 300

Зип Общепит
 3rd Version From s/n.213748 up Today
 2nd Version From s/n.144814 To s/n.213747
 vsezip.ru

ELECTRIC PARTS

+7(812)987-08-81

Common Parts

Ref.	Spare Description	Code
1	Bin Thermostat	23421
2	Evaporator Thermostat	23591
3	Timer	See Table
4	Contactor	23147
5	Orange Led with Lamp Cover	23100
8	Safety Pressure Switch	23342
9	Inlet Watervalue 2 Ways	23157
10	Hot Gas Coil	23091
11	Hot Gas Valve Body	20409
12	Pump	Current Version 23691
12	Pump	Till s/n. 213747 23068

Parts for Air-Cooled Version Only

Ref.	Spare Description	Code
6	Anti Radio Interference Filter	Only 220V 50 Hz, 230V 3 50 Hz, 400V 3N 50 Hz 23459
7	Condenser Pressure Switch	23175
13	Fan Motor	23121
14	Fan Motor	See Table

Ref. 3 - Timer

Tension	18g Cube	33g Cube	13g Cube
220/240V 50 Hz	23247	23248	23472
220/230V 60 Hz	23222	23396	23247
230V 3 50 Hz	23247	23248	23472
400V 3N 50 Hz	23247	23248	23472
220/230V 3 60 Hz	23222	23396	23247

Ref. 14 - Fan Motor

Tension	Code
220/240V 50 Hz	23067
220/230V 60 Hz	23681
230V 3 50 Hz	23067
400V 3N 50 Hz	23067
220/230V 3 60 Hz	23681

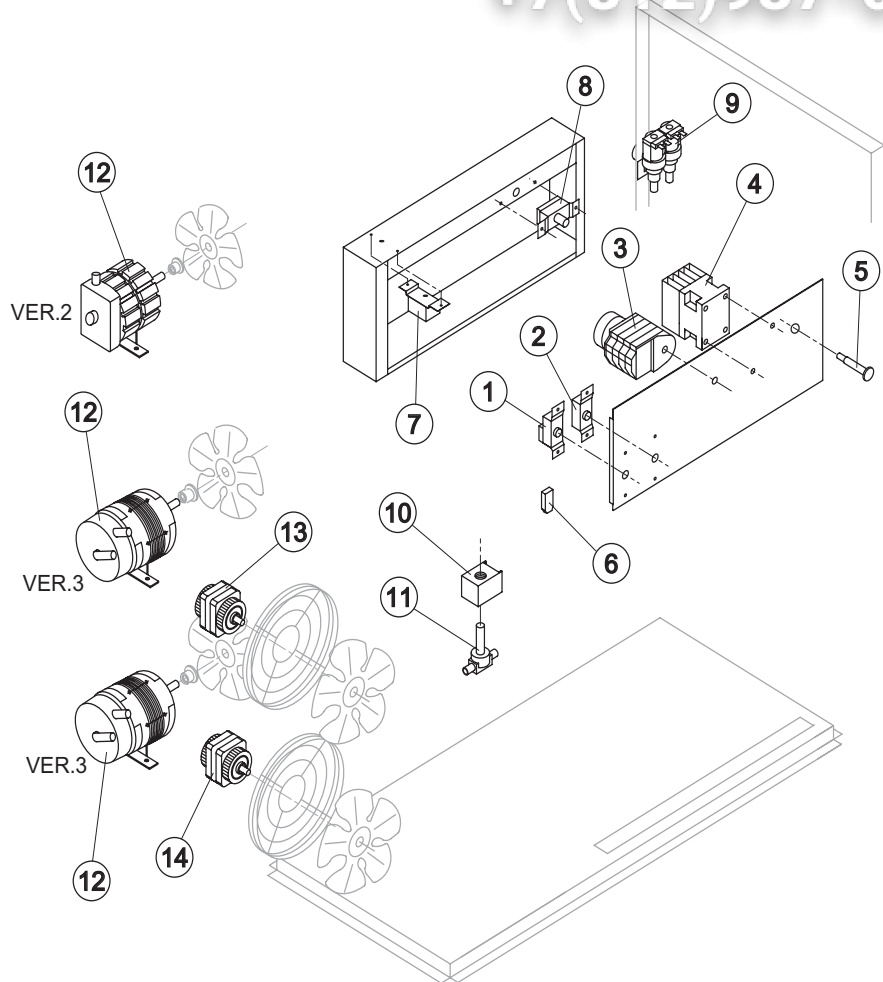

Rev. 3 - 20/10/2003



C 300

Зип Общепит

1st Version Till s/n.144813

vsezip.ru

SHELL ASSY

+7(812)987-08-81

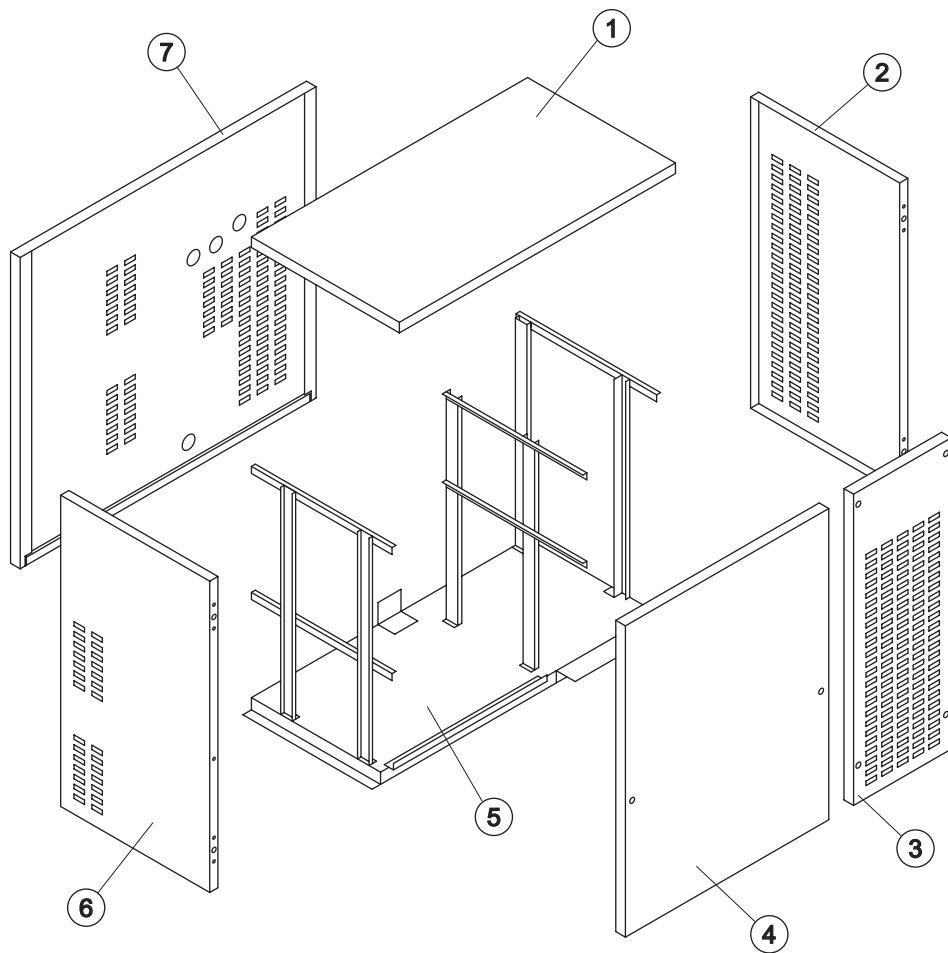

Ref.	Spare Description	Code
1	Top Assembly	C22481
2	Right Side	22483
3	Front Panel (Condenser Side)	22203
4	Front Panel (Basin Side)	C22432B
5	Base Plate	21110
6	Left Side	22482
7	Back Panel	22195

Rev. 3 - 20/10/2003



C 300

1st Version Till s/n.144813

Зип Общепит

vsezip.ru

+7(812)987-08-81

COOLING SYSTEM

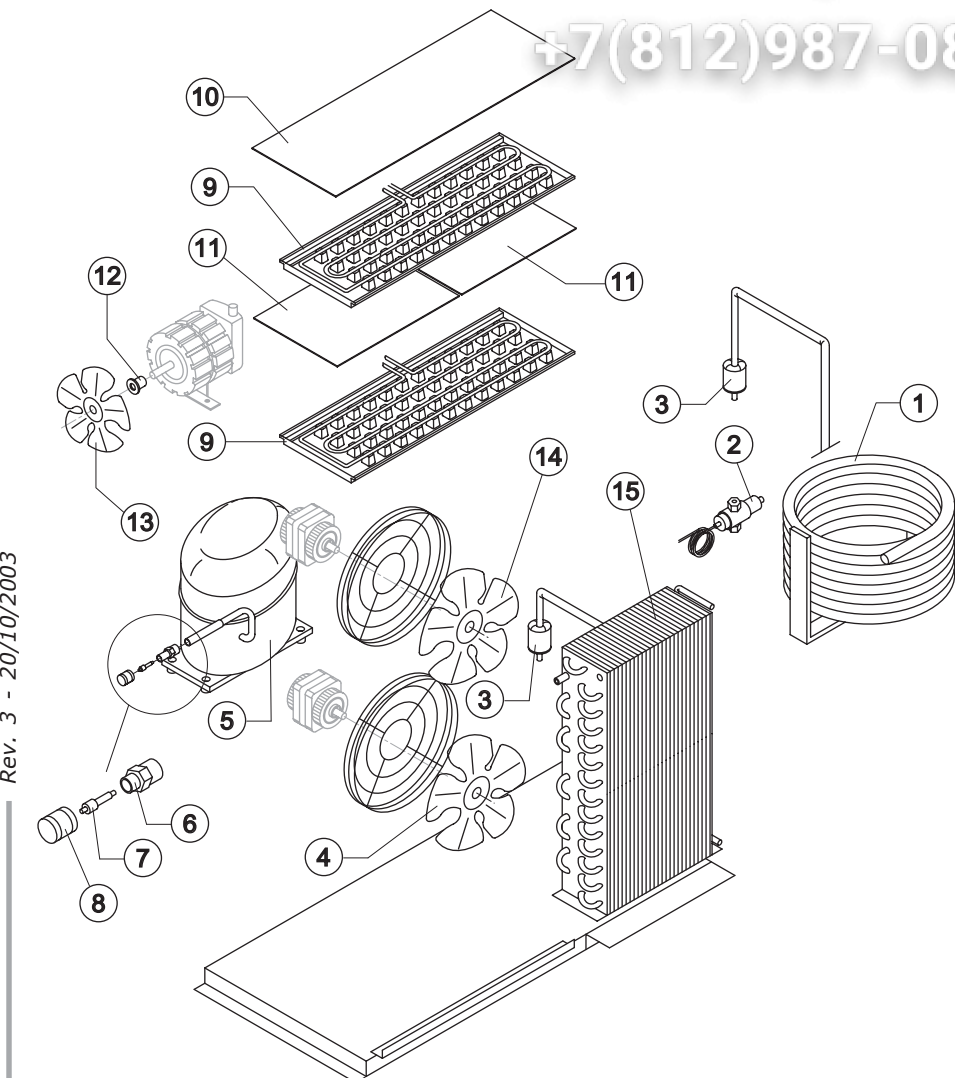

Common Parts

Ref.	Spare Description	Code
3	Solid Core Drier	14084
5	Compressor	See Table
6	Vacuum-Charge Valve Body	14007
7	Vacuum-Charge Valve Device	14005
8	Vacuum-Charge Valve Plug	14006
9	Evaporator	See Table
10	Evaporator Cover	10058
11	Evaporator Cover	10115
12	Hub for the Fan Fixing	10014
13	Suction Fan	10213

Parts for Air-Cooled Version Only

Ref.	Spare Description	Code
4	Suction Fan 254 / 31°	20031
14	Suction Fan 275 / 34°	20153
15	Air Condenser	20406

Parts for Water-Cooled Version Only

Ref.	Spare Description	Code
1	Water Condenser	14285
2	Pressure Valve	20149

Ref. 5 - Compressor

Tension	Code
220/240V 50 Hz	23489
220/230V 60 Hz	23527
230V 3 50 Hz	23563
400V 3N 50 Hz	23453
220/230V 3 60 Hz	23563

Ref. 9 - Evaporator

Kind of Cube	Code
18 g. (Standard)	D10214
33 g. (Big)	D10092
13 g. (Small)	D10126

Rev. 3 - 20/10/2003



C 300

1st Version Till s/n.144813

Зип Общепит

vsezip.ru

+7(812)987-08-81

HYDRAULIC CIRCUIT

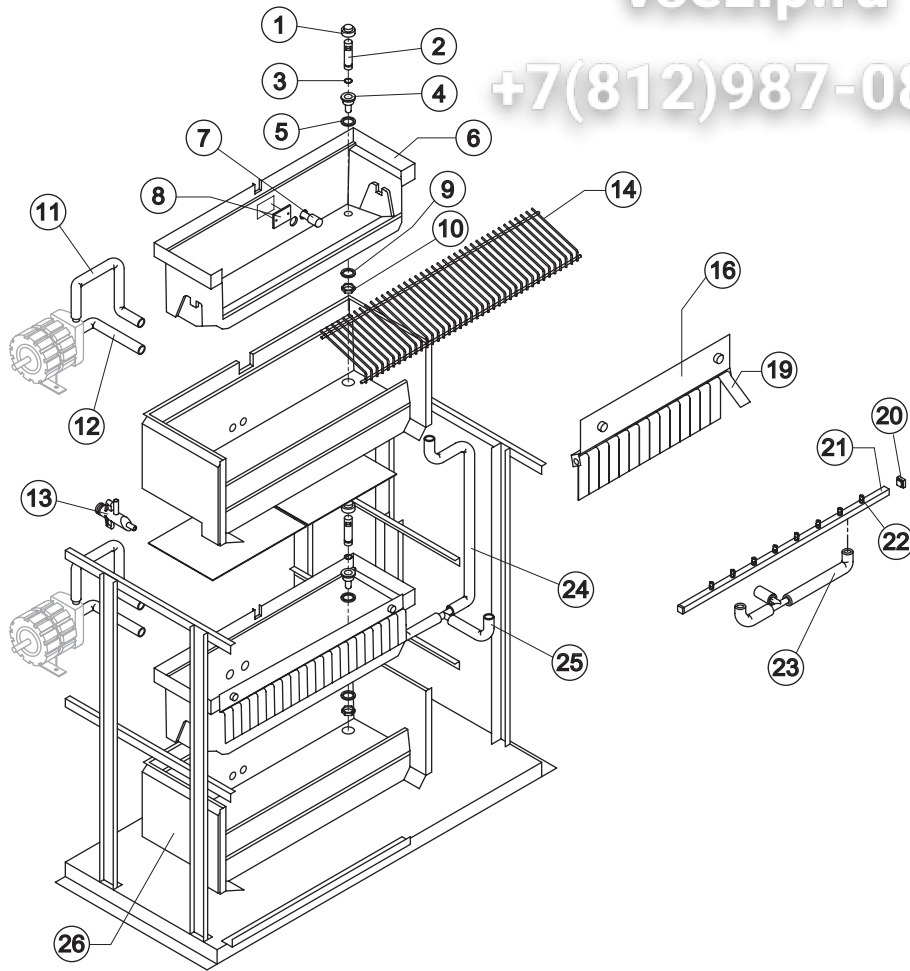

Common Parts

Ref.	Spare Description	Code
1	Overflow Cap	10305
2	Overflow Pipe	10133
3	OR Gasket for Overflow Pipe	20233
4	Plastic Nipple Water Outlet	10007
5	Silicone Gasket	13006
6	Inner Basin	10055
7	Pump Suction Filter	20005
8	Slide Keep Plate	10009
9	Semirigid Polyethylene Gasket	13007
10	Bin Discharge Nut	10096
11	Pump Delivery Pipe	13046
12	Pump Suction Pipe	13047
14	Ice Cubes Slide	See Table
16	Flags Support Assy	C22134
19	Flag	10005
20	Sprayers Bar Plug	10012
21	Sprayers Bar Assembly	See Table
22	Sprayer	D20002
23	Sprayers Bar Pipe Connection	C13036
24	Water Discharge Pipe (Upper Bin)	13048
25	Water Discharge Pipe (Lower Bin)	13049
26	Foamed Basin	C11067

Parts for Air-Cooled Version Only

Ref.	Spare Description	Code
13	Discharges Manifold	10006

Parts for Water-Cooled Version Only

Ref.	Spare Description	Code
13	Discharges Manifold	C10051

Ref. 14 - Ice Cubes Slide

Kind of Cube	Code
18 g. (Standard)	D12022
33 g. (Big)	D12033
13 g. (Small)	D12040

Ref. 21 - Sprayers Bar Ass.

Kind of Cube	Code
18 g. (Standard)	C20144
33 g. (Big)	C20157
13 g. (Small)	C20200



C 300

Зип Общепит

1st Version Till s/n.144813

vsezip.ru

+7(812)987-08-81

ELECTRIC PARTS

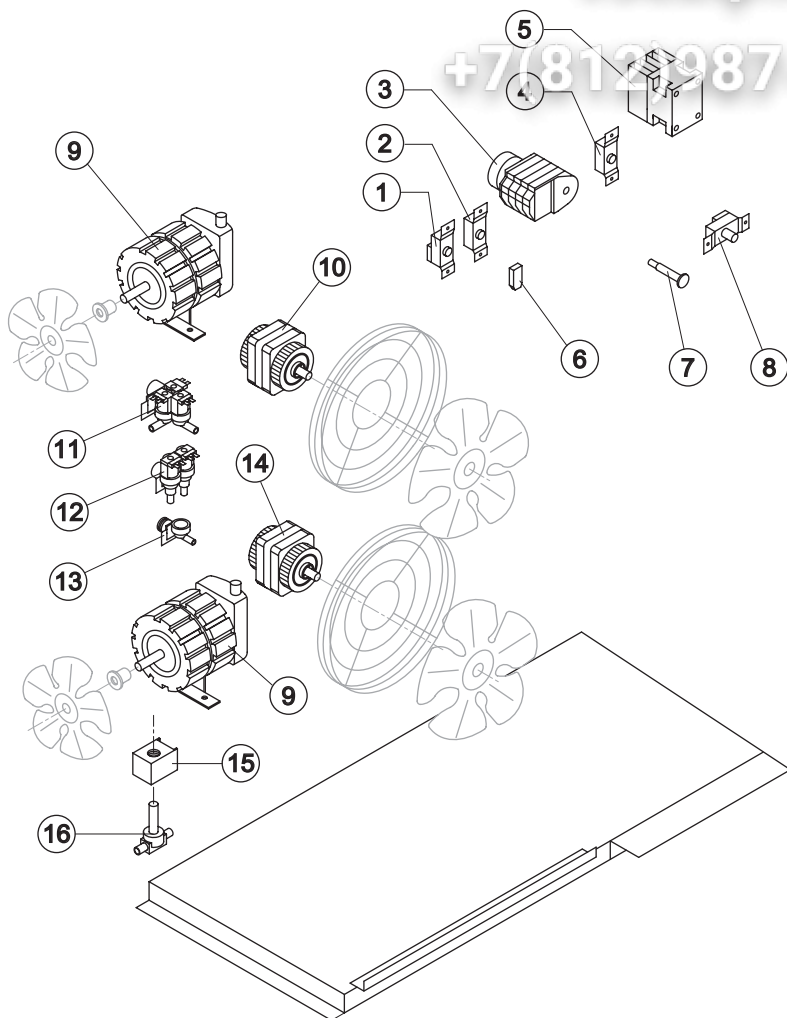

Common Parts

Ref.	Spare Description	Code
1	Bin Thermostat	23421
2	Evaporator Thermostat	23591
3	Timer	See Table
5	Contactors	23147
7	Orange Led with Lamp Cover	23100
8	Safety Pressure Switch	23342
9	Pump	23068
12	Inlet Watervalue 2 Ways	23157
15	Hot Gas Coil	23091
16	Hot Gas Valve Body	20409

Parts for Air-Cooled Version Only

Ref.	Spare Description	Code
4	Condenser Pressure Switch	23175
6	Anti Radio Interference Filter	Only 220V 50 Hz, 230V 3 50 Hz, 400V 3N 50 Hz
10	Lower Fan Motor	23121
14	Lower Fan Motor	See Table

Parts for Water-Cooled Version Only

Ref.	Spare Description	Code
11	Inlet Watervalue 3 Ways	Till s/n. 118439
13	Inlet Water Nipple 1 Way	10239

Ref. 3 - Timer

Tension	18g Cube	33g Cube	13g Cube
220/240V 50 Hz	23247	23248	23247
220/230V 60 Hz	23222	23396	23247
230V 3 50 Hz	23247	23248	23247
400V 3N 50 Hz	23247	23248	23247
220/230V 3 60 Hz	23222	23396	23247

Ref. 14 - Lower Fan Motor

Tension	Code
220/240V 50 Hz	23067
220/230V 60 Hz	23681
230V 3 50 Hz	23067
400V 3N 50 Hz	23067
220/230V 3 60 Hz	23681

Rev. 3 - 20/10/2003