

Зип Общерит
vsezip.ru

+7(812)987-08-81

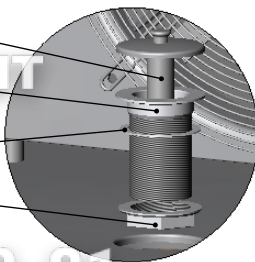

B

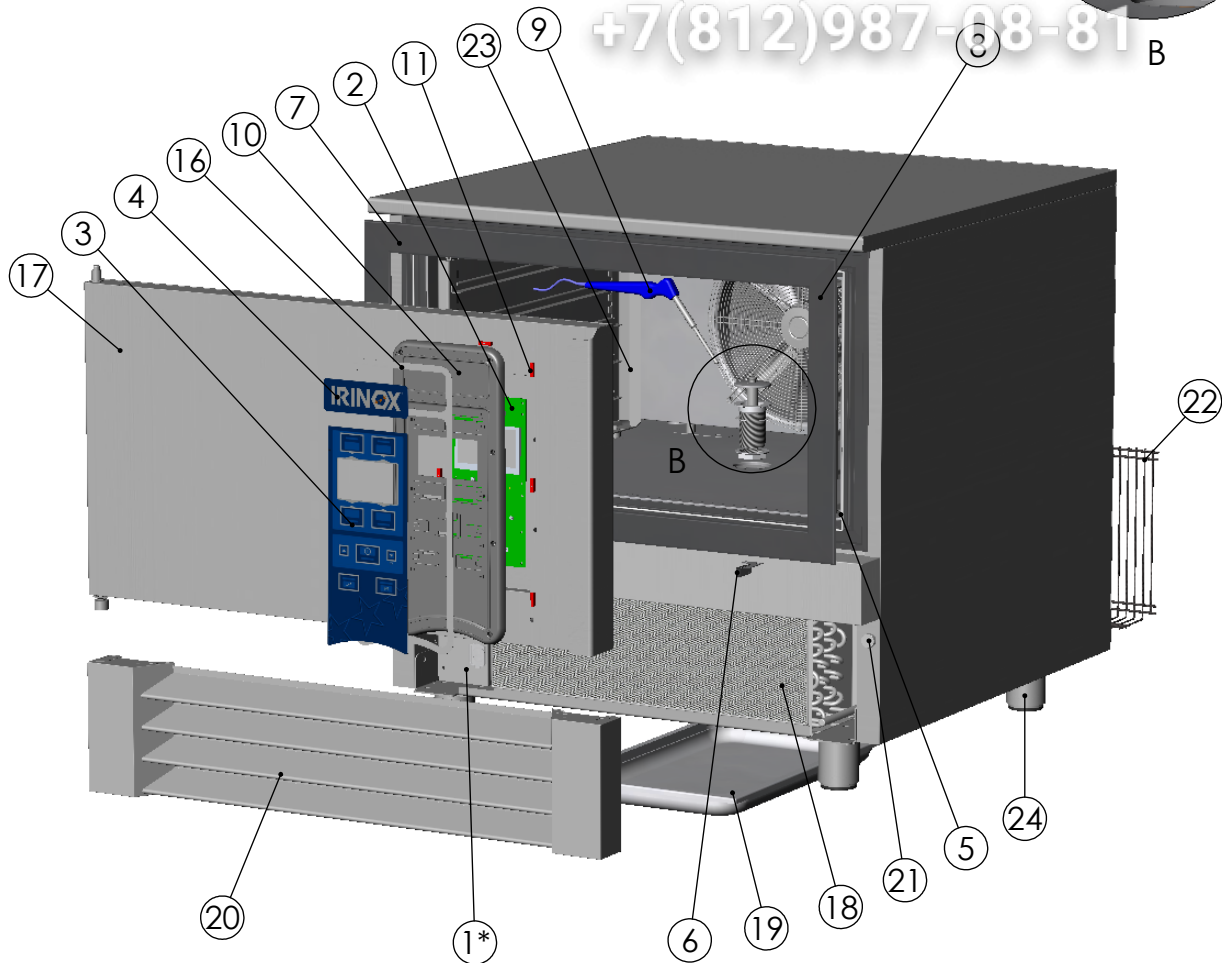

MF30.2

POS.	CODICE	Q.TA'
1*	41M05100100	1
2	3600810	1
3	4380100010	1
4	4380100020	1
5	2341318	1
6	3240100	1
7	4802172	2
8	4801161	2
9	3805500	1
10	1890600	1
11	3240250	9
12	40071080	1
13	11000050	1
14	11005010	1
15	11000080	1
16	68140810	1
17	7M7052000	1
18	4000216	1
19	1002000	1
20	68060700	1
21	3240200	2
22	48000033	1
23	8M10520000	1
24	40080210	4

* => COMPONENTI CHE VARIANO
CON LA TENSIONE DI ALIMENTAZIONE (VEDI TABELLA)

* => COMPONENTS DEPENDING ON POWER SUPPLY (SEE TABLE)

REV.	DESCRIZIONE MODIFICA	AUTORE	DATA
E			
D			
C			
B			
A			

IRINOX

SCALA: 1:10

MODELLO:

CODICE:

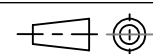

DESCRIZIONE:

ASSIEME CELLA MF30.2

Зип Общепит

sezip.ru

+7(812)987-08-81

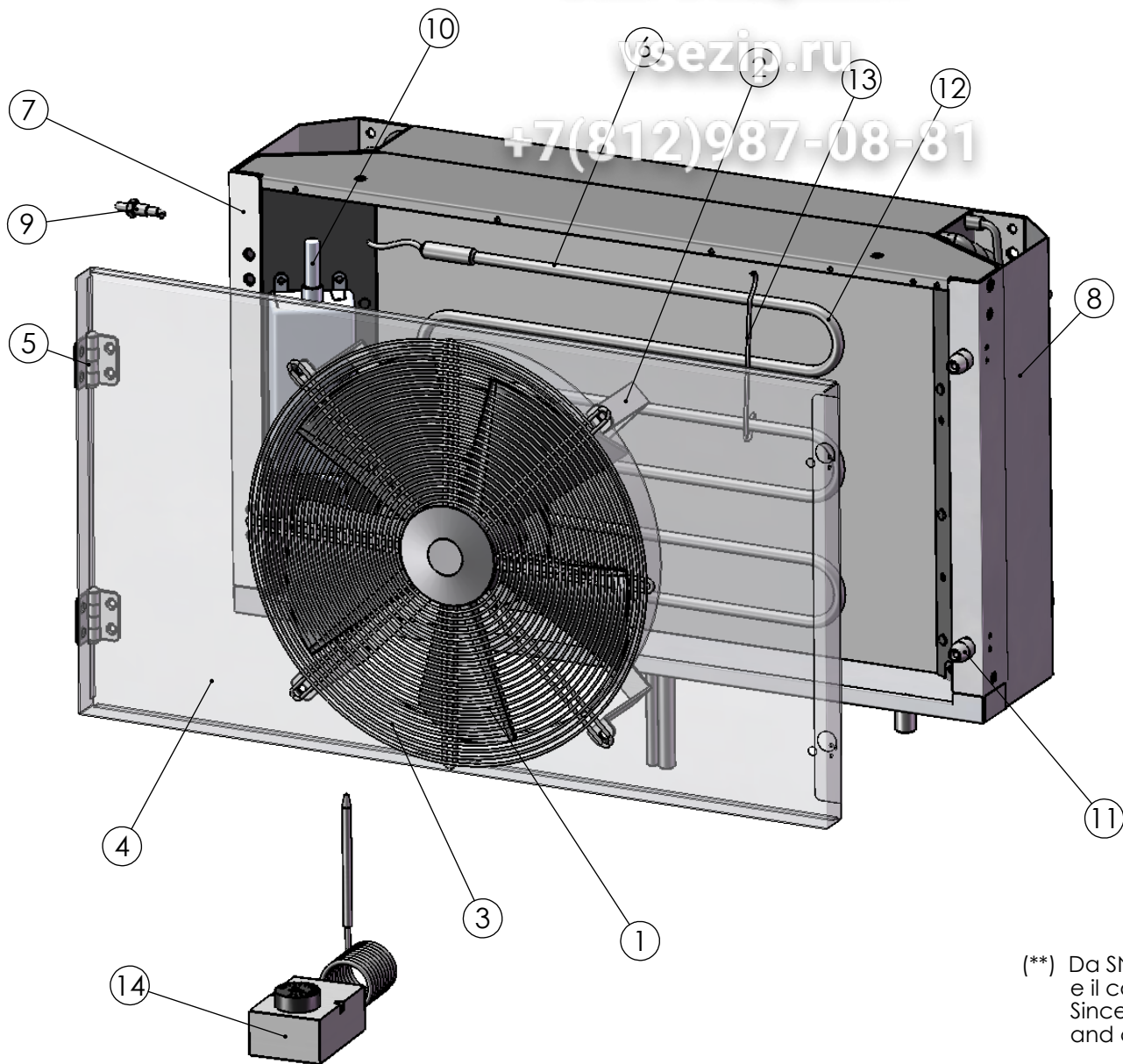

POS.	CODICE	Q.TA'
1	270343010 (**)	1
2	68142341 (**)	2
3	2783202	1
4	68060960	1
5	40002040	2
6	40207005	1
7	68060910	1
8	68060900	1
10	3880400	1
11	40051165	2
12	2341201	1
13	40071250	3
14	3340060	1

(**) Da SN: 031000057, il cod. 270343004 è sostituito con il cod. 270343010, e il cod. 68142340 è sostituito con il cod. 68142341.
 Since SN: 031000057, code 270343004 is replaced with code 270343010, and code 68142340 is replaced with code 68142341.

E			
D			
C			
B	aggiunto componenti plus	buttazzi	17.07.2012
A	modificato ventilatore e staffa da matricola 031000057	buttazzi	24.03.2010
REV	DESCRIZIONE MODIFICA	AUTORE	DATA

IRINOX

SCALA: 1:5

MODELLO:

CODICE:



DESCRIZIONE:

ASSIEME EVAP. E PORTAV. MF30.2

Зип Общепит
 vsezip.ru
 +7(812)987-08-81

POS.	CODICE	Q.TA'
1	68061200 (2)	2
2	40072080	4
3	40072090	4
4	68151273 (4)	10
5	11005060	4

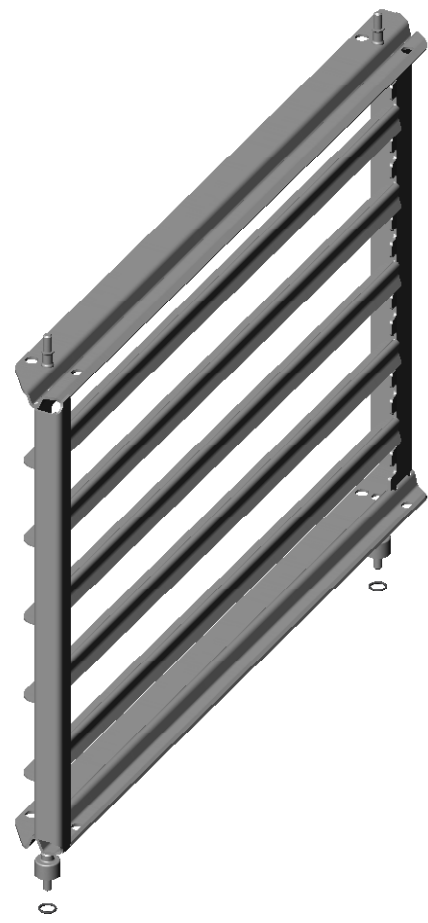
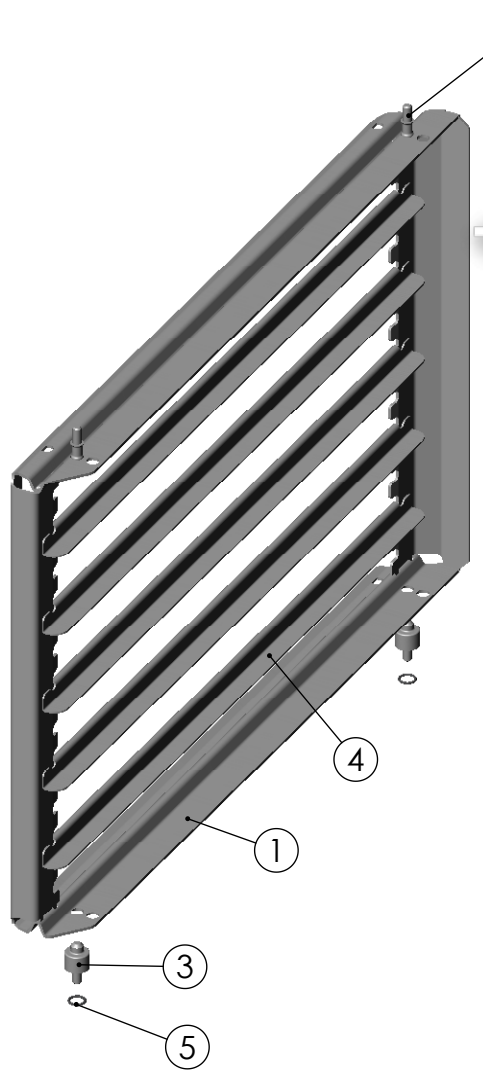

REV.	DESCRIZIONE MODIFICA	AUTORE	DATA
E			
D			
C			
B			
A			



SCALA: 1:8

MODELLO:

CODICE: **8M10520000**

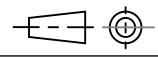

DESCRIZIONE:

OPZ. SUPP.TEGLIE GN2-1 MF30.2

2 Вип Общепит
 vsezip.ru
 +7(812)987-08-81

POS.	CODICE	Q.TA'
1	68061200 (2)	2
2	40072080	4
3	40072090	4
4	68151276 (7)	10
5	11005060	4

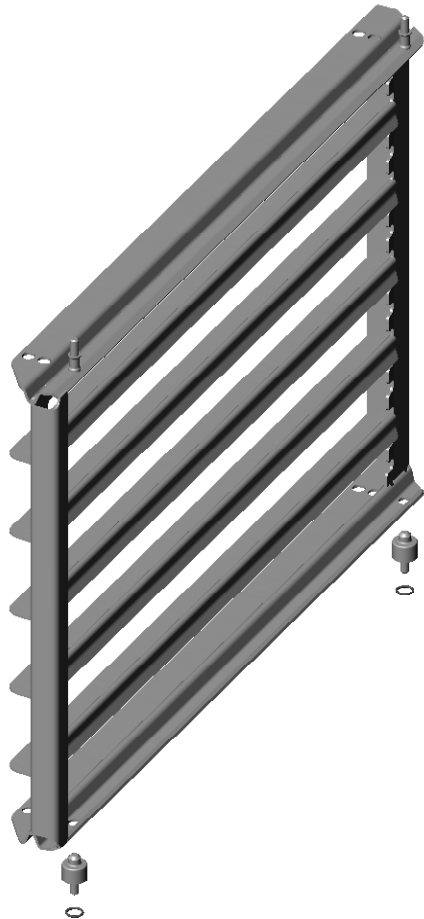
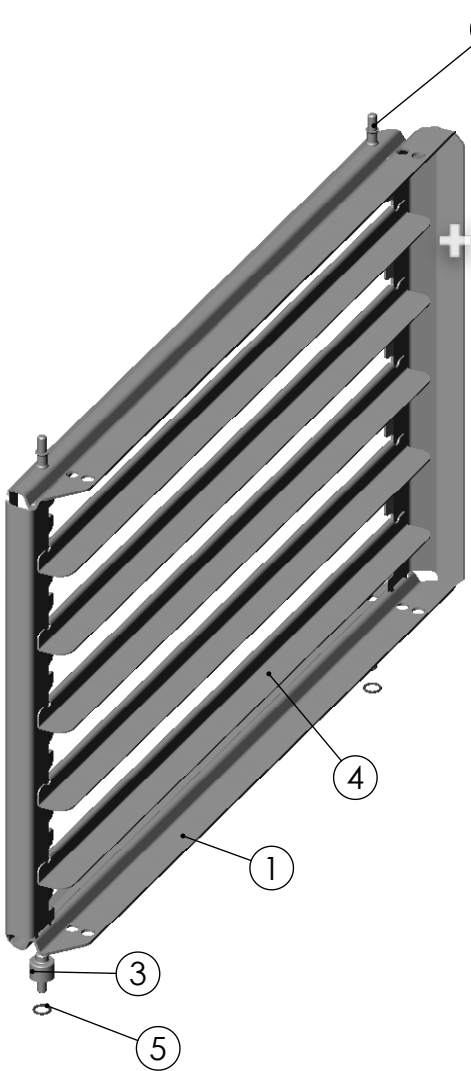

REV.	DESCRIZIONE MODIFICA	AUTORE	DATA
E			
D			
C			
B			
A			



SCALA: 1:8

MODELLO:

CODICE: **8M10520010**

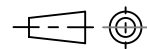

DESCRIZIONE:

OPZ. SUPP.TEGLIE PAST/USA MF30.2

Зип Общепит

vsezip.ru

+7(812)987-08-81

POS.	CODICE	Q.TA'
1	68061205	1
2	68151273 (4)	16
4	40072090	4
3	11005060	4

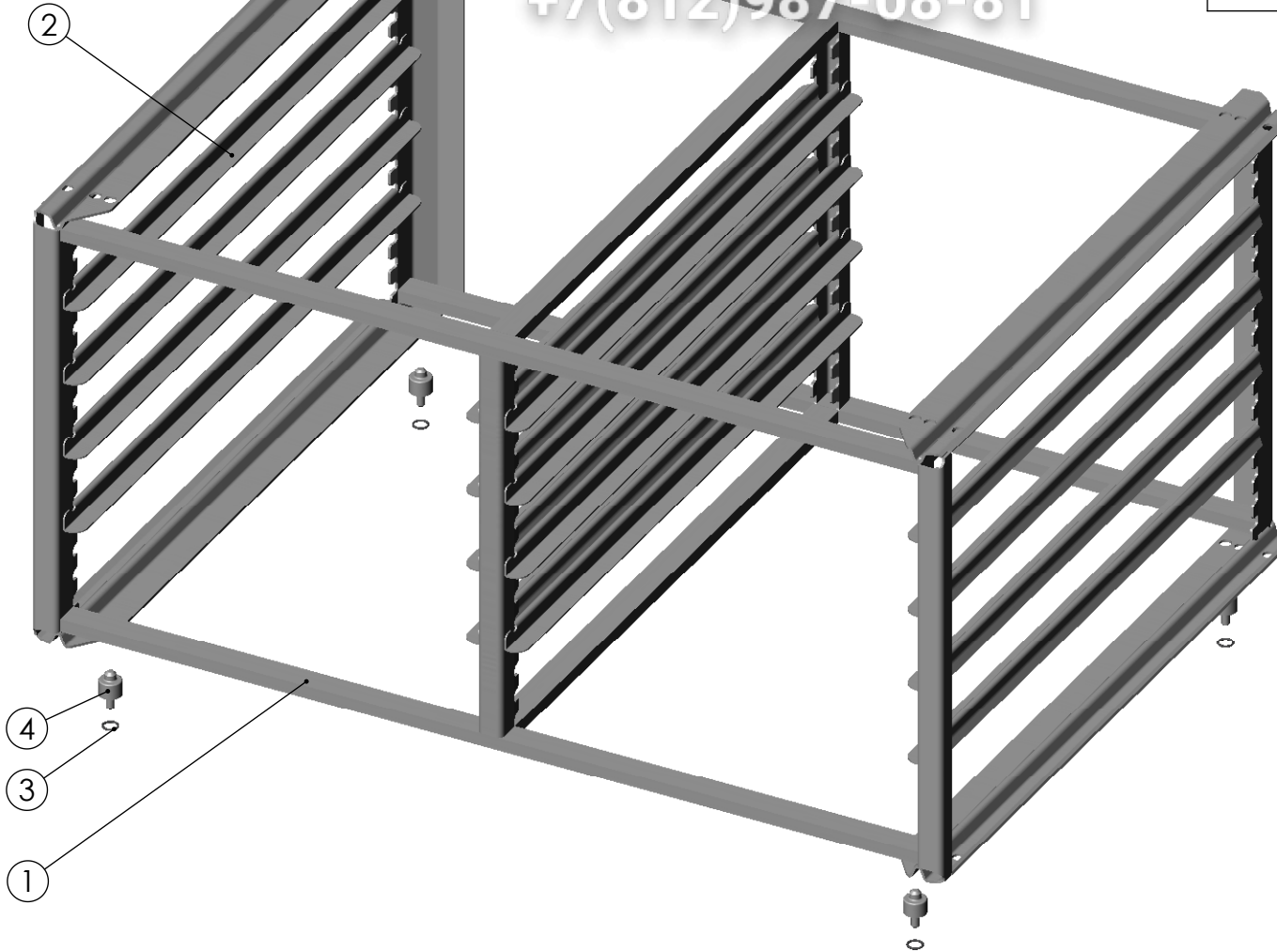

REV.	DESCRIZIONE MODIFICA	AUTORE	DATA
E			
D			
C			
B			
A			

IRINOX

SCALA: 1:5

MODELLO:

CODICE:

8M10520020

DESCRIZIONE:

ASSIEME SALD.SUP.TEGL.DOPPIO MF30.2

Зип Общепит

vsezip.ru

+7(812)987-08-81

PIEDINO STANDARD
REG. H=80...115mm

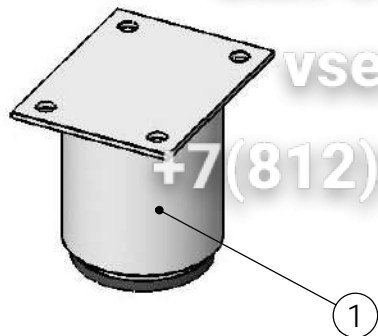

PIEDINO RIBASSATO
REG. H=60...80mm

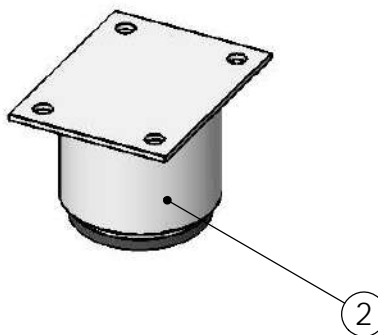

RUOTA H=95mm

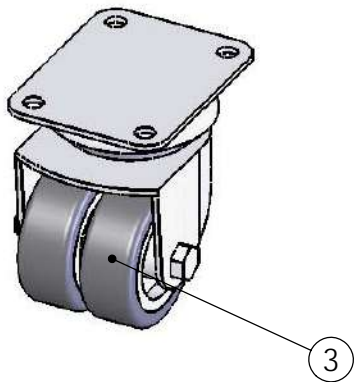

POS.	CODICE	Q.TA'
1	40080210	4
2	40080220	4
3	19003030	4

E			
D			
C			
B			
A			
REV.	DESCRIZIONE MODIFICA	AUTORE	DATA

IRINOX

SCALA: 1:3

MODELLO:

CODICE:

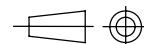

DESCRIZIONE:

PIEDINI E RUOTE

Зип Общепит

vsezip.ru

+7(812)987-08-81

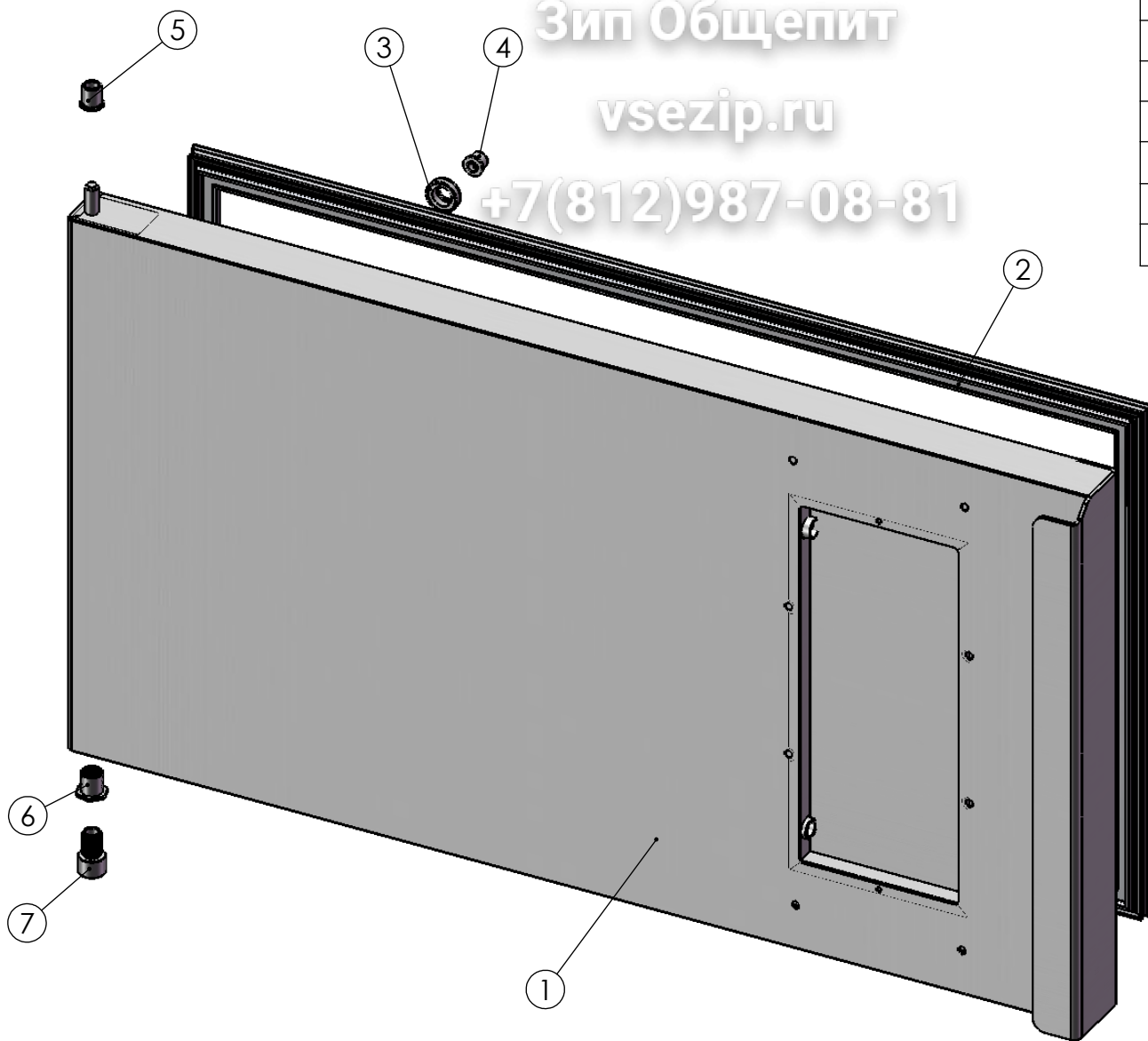

POS.	CODICE	Q.TA'
1	68060500	1
2	1010106	1
3	40051330	1
4	40051340	1
5	40011085	1
6	40051311	1
7	40051301	1

REV.	DESCRIZIONE MODIFICA	AUTORE	DATA
E			
D			
C			
B			
A			

IRINOX

SCALA: 1:5

MODELLO:

CODICE: **7M7052000**

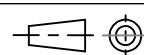

DESCRIZIONE:

GRUPPO PORTA SX MF30.2

Зип Общепит

vezip.ru

+7(812)987-08-81

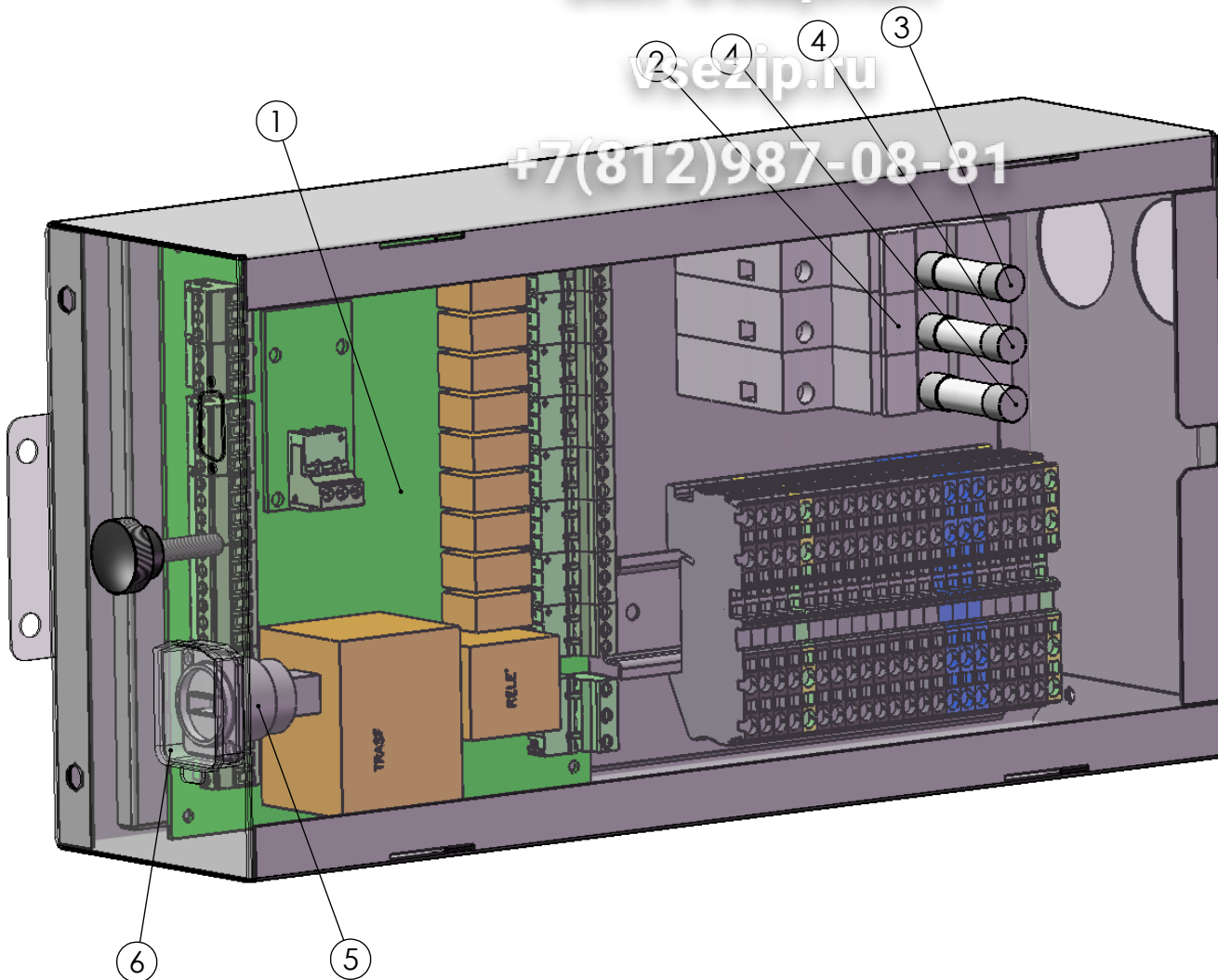

POS.	CODICE	Q.TA'
1	3600800	1
2	3440140	3
3	3440023	1
4	3440075	2
5	3563270	1
6	3563275	1

REV.	DESCRIZIONE MODIFICA	AUTORE	DATA
E			
D			
C			
B			
A			

IRINOX[®]

SCALA: 1:2

MODELLO: **MF25.1/30.2**

CODICE: **41M05100100**

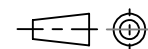

DESCRIZIONE: **QUADRO MF25.1/30.2 230-1N-50/60**

Зип Ощепит

vsezip.ru

+7(812)987-08-81

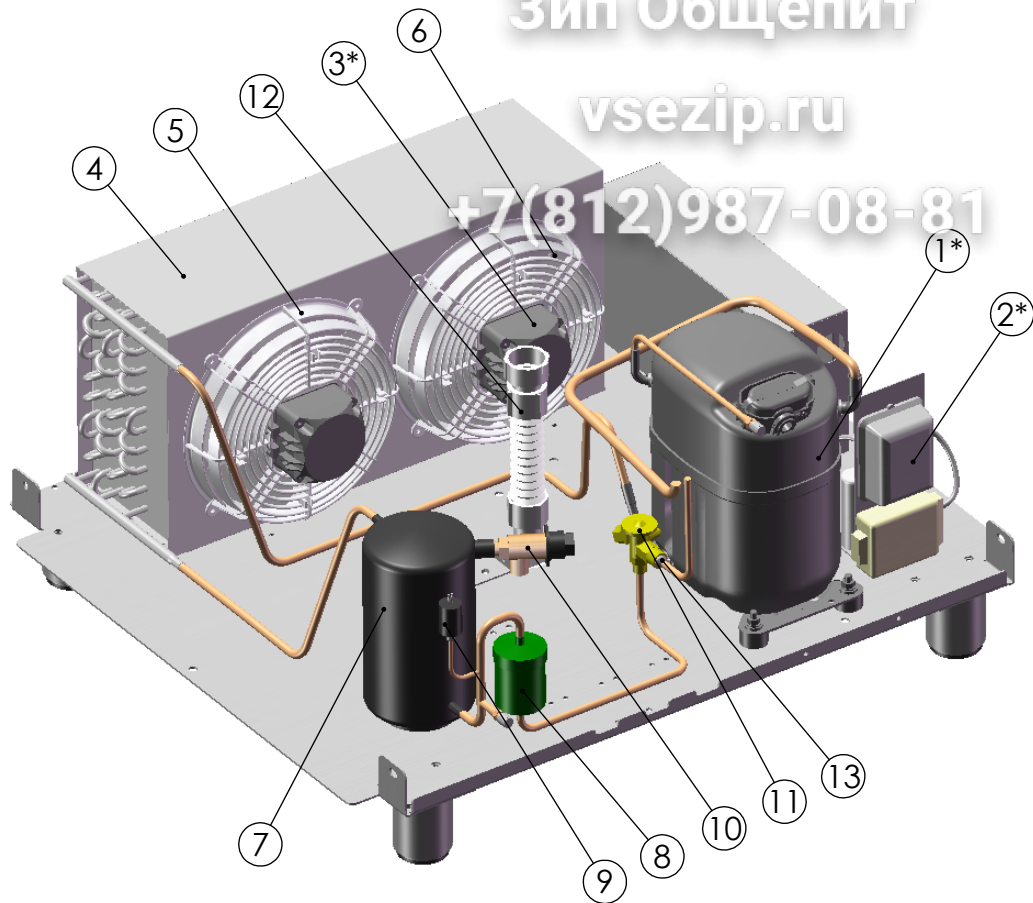

**UNITA' CONDENSANTE INCORPORATA MF30.2
CON CONDENSAZIONE AD ARIA**

**INCORPORATED CONDENSING UNIT MF30.2
WITH AIR CONDENSATION**

POS.	CODICE	Q.TA'
1*	2500960	1
2*	2582003	1
3*	2710220014	2
4	40218001	1
5	2746040	2
6	2780320038	2
7	2382100	1
8	23310389	1
9	23421104	1
10	23091031	1
11	23605052	1
12	11000040	1
13	2361001	1

* => COMPONENTI CHE VARIANO
CON LA TENSIONE DI ALIMENTAZIONE (VEDI TABELLA)

* => COMPONENTS DEPENDING ON POWER SUPPLY (SEE TABLE)

REV.	DESCRIZIONE MODIFICA	AUTORE	DATA
E			
D			
C			
B			
A			

IRINOX

SCALA: 1:8

MODELLO: **MF30.2**

CODICE:

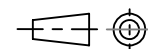

DESCRIZIONE:

GR. CONDENSANTE MF30.2

Зип Ощепит

vsezip.ru

+7(812)987-08-81

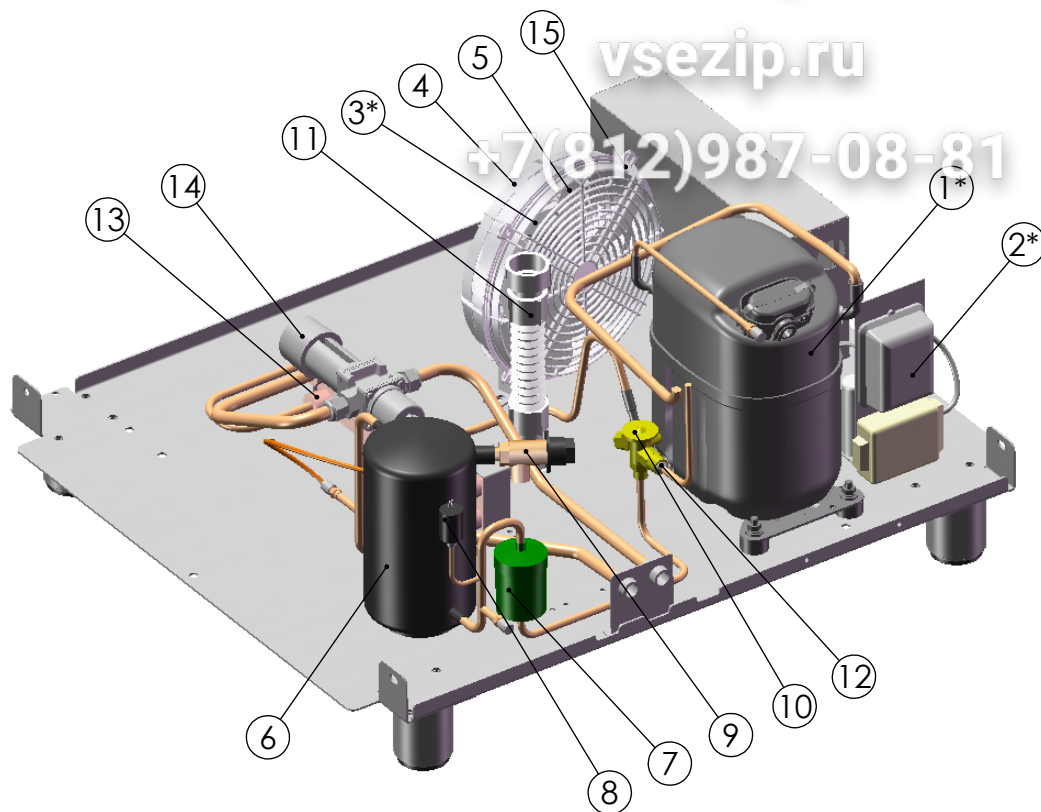

**UNITA' CONDENSANTE INCORPORATA MF30.2
CON CONDENSAZIONE AD ACQUA**

**INCORPORATED CONDENSING UNIT MF30.2
WITH LINE WATER CONDENSATION**

POS.	CODICE	Q.TA'
1*	2500960	1
2*	2582003	1
3*	2710220014	1
4	2746040	1
5	2780320038	1
6	2382100	1
7	23310389	1
8	23421101	1
9	23091028	1
10	23605052	1
11	11000040	1
12	2361001	1
13	40211117	1
14	2345212	1
15	2746050	1

* => COMPONENTI CHE VARIANO
CON LA TENSIONE DI ALIMENTAZIONE (VEDI TABELLA)

* => COMPONENTS DEPENDING ON POWER SUPPLY (SEE TABLE)

REV.	DESCRIZIONE MODIFICA	AUTORE	DATA
E			
D			
C			
B			
A			

IRINOX

SCALA: 1:8

MODELLO: **MF30.2**

CODICE:

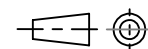

DESCRIZIONE:

GR. CONDENSANTE MF30.2

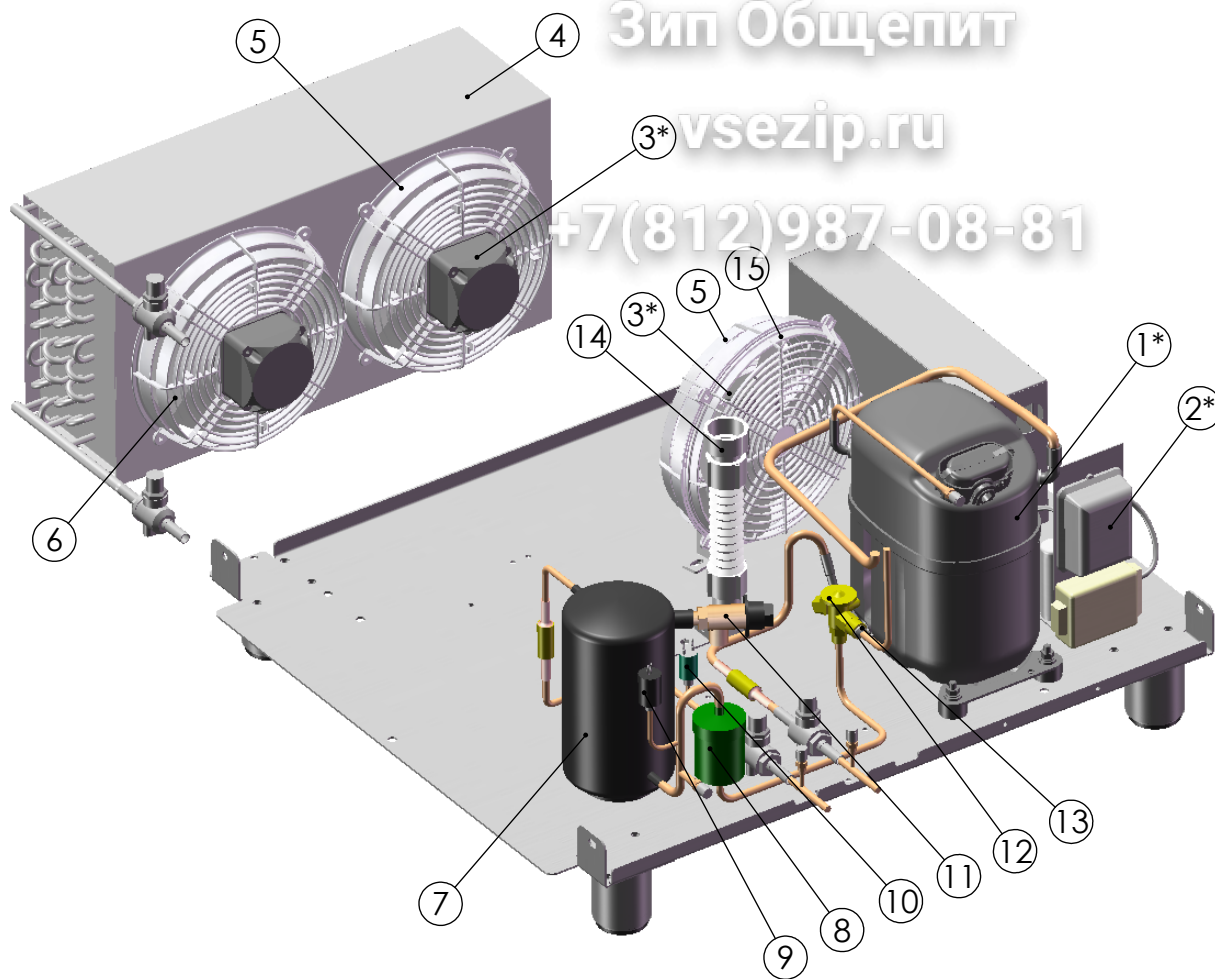

Зип Общепит
vsezip.ru
+7(812)987-08-81

**UNITA' CONDENSANTE INCORPORATA MF30.2
CON CONDENSATORE AD ARIA REMOTO**

**INCORPORATED CONDENSING UNIT MF30.2
WITH REMOTE AIR CONDENSER**

POS.	CODICE	Q.TA'
1*	2500960	1
2*	2582003	1
3*	2710220014	3
4	40218001	1
5	2746040	3
6	2780320038	3
7	2382100	1
8	23310389	1
9	23421104	1
10	23421103	1
11	23091031	1
12	23605052	1
13	2361001	1
14	11000040	1
15	2746050	1

* => COMPONENTI CHE VARIANO
CON LA TENSIONE DI ALIMENTAZIONE (VEDI TABELLA)

* => COMPONENTS DEPENDING ON POWER SUPPLY (SEE TABLE)

REV.	DESCRIZIONE MODIFICA	AUTORE	DATA
E			
D			
C			
B			
A			

IRINEX®

SCALA: 1:8

MODELLO: **MF30.2**

CODICE:



DESCRIZIONE:

GR. CONDENSANTE MF30.2

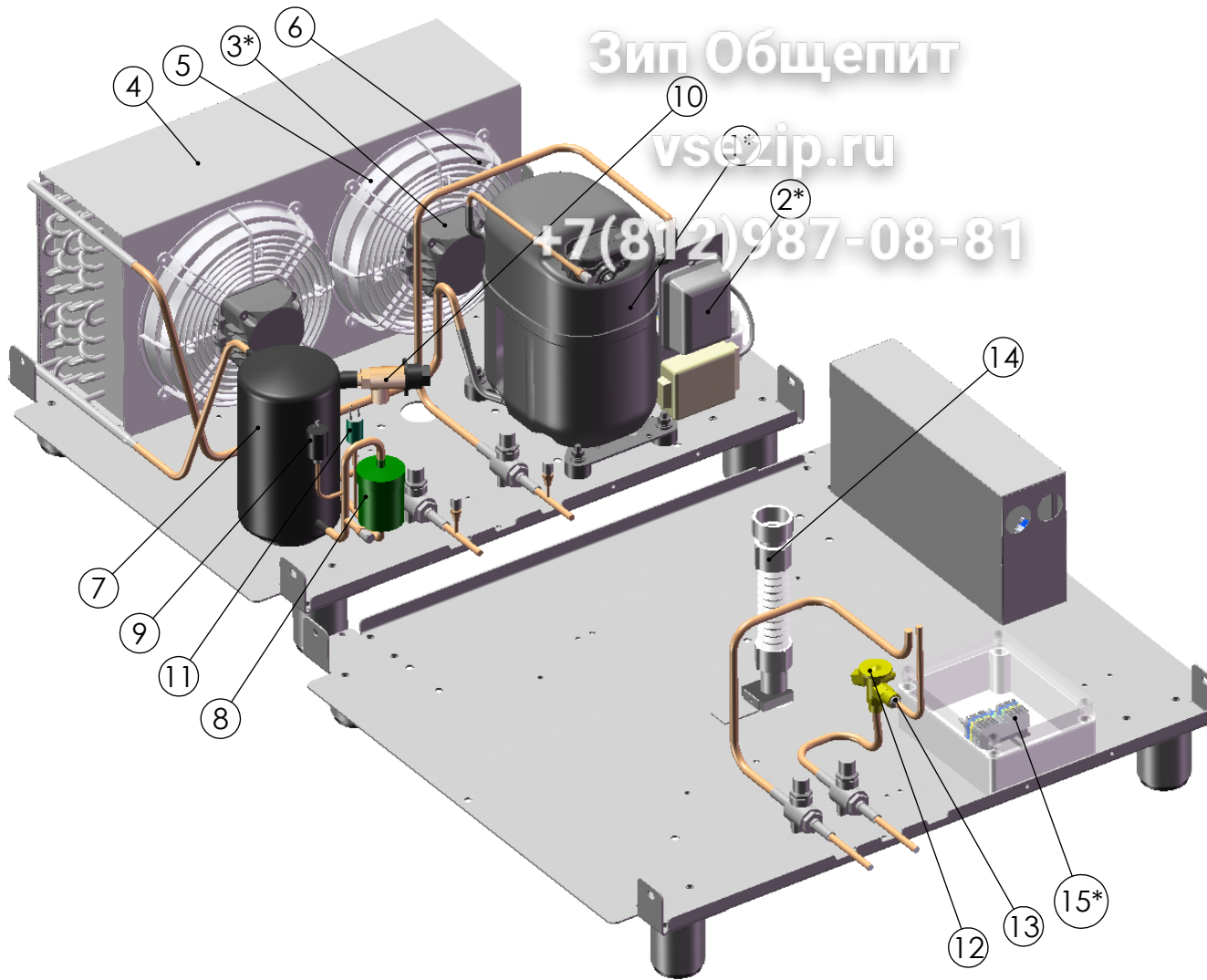

Зип Общепит
 vsezip.ru
 +7(812)987-08-81

POS.	CODICE	Q.TA'
1*	2500960	1
2*	2582003	1
3*	2710220014	2
4	40218001	1
5	2746040	2
6	2780320038	2
7	2382100	1
8	23310389	1
9	23421104	1
10	23091031	1
11	23421103	1
12	23605052	1
13	2361001	1
14	11000040	1
15*	41M05120100	1

* => COMPONENTI CHE VARIANO
 CON LA TENSIONE DI ALIMENTAZIONE (VEDI TABELLA)

* => COMPONENTS DEPENDING ON POWER SUPPLY (SEE TABLE)

**UNITA' CONDENSANTE MF30.2
 CON GRUPPO ARIA REMOTO**

**CONDENSING UNIT MF30.2
 WITH REMOTE AIR CONDENSATION**

REV.	DESCRIZIONE MODIFICA	AUTORE	DATA
E			
D			
C			
B			
A			



SCALA: 1:8

MODELLO: **MF30.2**

CODICE:

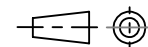

DESCRIZIONE: **GR. CONDENSANTE MF30.2**

Зип Общепит

TABELLA COMPONENTI VARIABILI CON LA TENSIONE
CHANGE COMPONENTS WITH VOLTAGE TABLE

MODELLO <i>MODEL</i>	COMPONENTE <i>COMPONENT</i>	GAMMA TENSIONI / <i>VOLTAGE RANGE</i>		
		220V-1P+N-50Hz	220V-1P+N-60Hz	200V-2P-50/60Hz
MF 30.2	Compressore <i>Compressor</i>	2500960	2500965	2500965
	Parte elettrica compressore <i>electric component compressor</i>	2582003	2582004	2582004
	Ventilatore condensatore <i>Condenser fan</i>	2710220014	2710220014	2710220015
	Ventilatore compressore <i>Compressor fan</i>	2710220014	2710220014	2710220015
	Quadro elettrico <i>Electrical panel</i>	41M05100100	41M05100100	41M05100500
	Quadro derivazione <i>Junction panel</i>	41M05120100	41M05120100	41M05220700

COD.	ITALIANO	ENGLISH	ESPAÑOL	DEUTSCH
1002000	BACINELLA 1/1 GN H.40 POLIS.BIANCO	BASIN 1/1 GN H.40 POLIS. WHITE	CUBETA 1/1 GN H.40 POLIS.BLANCO	SCHÜSSEL 1/1 GN H.40 POLYS.WEISS
1010106	GUARNIZIONE PORTA MF30.2	DOOR GASKET MF30.2	GUARNICIÓN PUERTA MF30.2	TÜRDICHTUNG MF30.2
1890600	CRUSCOTTO MULTI FRESH	MULTI FRESH DASHBOARD	PANEL DE MANDOS MULTI FRESH	BEDIENTAFEL MULTI FRESH
2341201	RESISTENZA 750W 220V	HEATER 750W 220V	RESIST. 750W 220V	WIDERST. 750W 220V
2341318	RESIST. PORTA MF30.2 35W 230V	RES. ST. DOOR MF30.2 35W 230V	RESIST. PUERTA MF30.2 35W 230V	WIDERST. TÜR MF30.2 35W 230V
2345212	VALVOLA ACQUA 3/8" WVFX 10 003N1100	WATER VALVE 3/8" WVFX 10 003N1100	VÁLVULA AGUA 3/8" WVFX 10 003N1100	WASSERVENTIL 3/8" WVFX 10 003N1100
2361001	ORIFICIO N. 01 T/TE 2 68-2021	ORIFICE N. 01 T/TE 2 68-2021	ORIFICIO N. 01 T/TE 2 68-2021	ABLAUF N. 01 T/TE 2 68-2021
2382100	RICEVITORE LIQUIDO D.120X241 LT2.3	LIQUID RECEIVER D.120X241 L2.3	RECEPTOR LÍQUIDO D.120X241 LT2.3	FLÜSSIGKEITSTANK D.120X241 L 2.3
2500037	COMPRES.DANF.GS26CLX 107B0500	COMPRES.DANF.GS26CLX 107B0500	COMPRES.DANF.GS26CLX 107B0500	KOMPRES.DANF.GS26CLX 107B0500
2581170	PARTE EL. COMP.DANF.GS26CLX 220V-50	PART EL. COMP.DANF.GS26CLX 220V-50	PARTE EL. COMP.DANF.GS26CLX 220V-50	EL.TEIL KOMP.DANF.GS26CLX 220V-50
2746040	BOCCAGLIO PER VENTOLA D230	NOZZLE FOR FAN D230	BOCA PARA VENTILADOR D230	DÜSE FÜR LÜFTUNG D230
2746050	GRIGLIA PROTETTIVA D.230	PROTECTION GRILL D.230	REJILLA DE PROTECCIÓN D.230	SCHUTZGITTER D.230
2783202	GRIGLIA PROTEZ.VENT. D.340 PIANA	FLAT D.340 VENT. PROTECTION GRILL	REJILLA PROTEC.VENT. D.340 PLANA	FLACHES SCHUTZGITTER LÜFT. D.340
3240100	CONT.MAGN. E510 1B 2PT296A U.L. 3MT	MAGN. CONT. E510 1B 2PT296A U.L. 3MT	CONT.MAGN. E510 1B 2PT296A U.L. 3MT	MAGN:KONTAKT E510 1B 2PT296A U.L. 3MT
3240200	MAGNETE M610 SIGILLATO NEODIMIO	SEALED MAGNET M610 NEODIMIO	IMÁN M610 SELLADO NEODIMIO	VERSIEG.NEODYMMAGNET M610
3340060	TERMOSTATO F/2000 30/120	THERMOSTAT F/2000 30/120	TERMOSTATO F/2000 30/120	TEMPERATURREGLER F/2000 30/120
3240250	MAGNETE NEODIMIO 20 X 5 X 5	NEODIMIO MAGNET 20 X 5 X 5	IMÁN NEODIMIO 20 X 5 X 5	NEODYMMAGNET 20 X 5 X 5
3440023	FUSIBILE 10,3 X 38 1A TIPO AM	FUSE 10.3 X 38 1A AM TYPE	FUSIBLE 10,3 X 38 1A TIPO AM	SICHERUNG 10,3 X 38 1A BAUART AM
3440075	FUSIBILE 10,3 X 38 12A TIPO AM	FUSE 10.3 X 38 12A AM TYPE	FUSIBLE 10,3 X 38 12A TIPO AM	SICHERUNG 10,3 X 38 12A BAUART AM
3440140	PORTAFUSIBILE 10.3X38 BCH1X38	FUSE-HOLDER 10.3X38 BCH1X38	PORTAFUSIBLE 10.3X38 BCH1X38	SICHERUNGSHALTER 10.3X38 BCH1X38
3563270	CONN.USB DA PANN.F/F A/B "NTNAUSB"	CONN.USB FROM PANEL F/F A/B "NTNAUSB"	CON.USB DE PAN.F/F A/B "NTNAUSB"	USB - ANSCHL. F.TAFEL F/F A/B "NTNAUSB"

3563275	TAPPO PLASTICA CONN.USB "NTCHSCDX"	PLASTIC CAP CONN.USB "NTCHSCDX"	TAPÓN PLÁSTICO CON.USB "NTCHSCDX"	PLASTICKDECKEL USB - ANSCHL. "NTCHSCDX"
3600800	SCHEDA GESTIONE MULTI FRESH	MULTI FRESH MANAGING BOARD	TARJETA GESTIÓN MULTI FRESH	VERWALTUNGSKARTE MULTI FRESH
3600810	SCHEDA FRONTALE MULTI FRESH	MULTI FRESH FRONT BOARD	TARJETA FRONTAL MULTI FRESH	FRONTKARTE MULTI FRESH
3805140	SONDA ARIA PT1000 L=3300MM C/SCHERM	AIR PROBE PT1000 L=3300MM W/SCREEN	SONDA AIRE PT1000 L=3300MM C/BLINDAJE	LUFTSONDE PT1000 L=3300MM M/SCHIRM
3805500	SONDA CUORE PT1000 CONICA 5P S/C	CORE PROBE PT1000 CONIC 5P S/C	SONDA CORAZÓN PT1000 CÓNICA 5P S/C	KONISCHE KERNSONDE PT1000 5P O/M
3880400	SANIGEN IRINOX BXMIRIX230V	SANIGEN IRINOX BXMIRIX230V	SANIGEN IRINOX BXMIRIX230V	SANIGEN IRINOX BXMIRIX230V
4000216	FILTRO ARIA PAN.COND.565X260X3 MF30.2	COND. PANEL AIR FILTER 565X260X3 MF30.2	FILTRO AIRE PAN.COND.565X260X3 MF30.2	LUFTFILTER TAF.KOND.565X260X3 MF30.2
4801161	COPERCHIO VERT. PROF.SCHIUM. CELLA MF30.2	CELL SKIM. PROF. VERT. LID MF30.2	TAPA VERT. PERFIL ESP. CELDA MF30.2	GESCH.TIEF.VERT.ABDECKUNG ZELLE MF30.2
4802172	COPERCHIO ORIZ.X CORN.'08 MF30.2	HORIZ. LID X CORN.'08 MF30.2	TAPA HORIZ.X CORN.'08 MF30.2	HORI.ABDECKUNG X RAHM.'08 MF30.2
11000040	TUBO SCARICO FLES.4300.00BN	FLEX. DRAIN PIPE 4300.00BN	TUBO DESCARGA FLEX.4300.00BN	FLEX.ABLASSLEITUNG.4300.00BN
11000050	PILETTA SCARICO 10110/3/1	DRAIN 10110/3/1	CONO DESCARGA 10110/3/1	AUSLAUF 10110/3/1
11000080	GHIERA PER PILETTA 9926	RING NUT FOR DRAIN 9926	ABRAZADERA PARA CONO 9926	RING FÜR AUSLAUF 9926
11005010	GUARNIZIONE PILETTA T05014	DRAIN GASKET T05014	GUARNICIÓN CONO T05014	DICHTUNG F.AUSLAUF T05014
11005060	GUARNIZ. OR 108	GASKET OR 108	GUARNIC. OR 108	DICHTU. HO 108
19003030	RUOTA DOPPIA 60X22+STAFFA D170D2060	DOUBLE WHEEL 60X22+BRACKET D170D2060	RUEDA DOBLE 60X22+BRIDA D170D2060	DOPPELTES RAD 60X22+BÜGEL D170D2060
23091028	VALVOLA SICUREZZA 1/4 PI28,5 PA30	SAFETY VALVE 1/4 PI28.5 PA30	VÁLVULA SEGURIDAD 1/4 PI28,5 PA30	SICHERHEITSVENTIL 1/4 PI28,5 PA30
23091031	VALVOLA SICUREZZA 1/4 PI29,5 PA33	SAFETY VALVE 1/4 PI29.5 PA33	VÁLVULA SEGURIDAD 1/4 PI29,5 PA33	SICHERHEITSVENTIL 1/4 PI29,5 PA33
23310389	FILTRO GMC SC033 M10S A SILDARE	FILTER GMC SC033 M10S TO WELD	FILTRO GMC SC033 M10S SOLDAR	FILTER GMC SC033 M10S Z.ANSCHW.
23421101	PRESS.ACB-2UC85W 25/20BAR 061F9077	PRESS.ACB-2UC85W 25/20BAR 061F9077	PRES.ACB-2UC85W 25/20BAR 061F9077	DRUCKW.ACB-2UC85W 25/20BAR 061F9077

23421103	PRESS.ACB-2UA389W 17/14.5 061F8482	PRESS.ACB-2UA389W 17/14.5 061F8482	PRES.ACB-2UA389W 17/14.5 061F8482	DRUCKW.ACB-2UA389W 17/14.5 061F8482
23421104	PRESS.ACB-2UC05W 27.6/20.7 061F3205	PRESS.ACB-2UC05W 27.6/20.7 061F3205	PRES.ACB-2UC05W 27.6/20.7 061F3205	DRUCKW.ACB-2UC05W 27.6/20.7 061F3205
23605052	VALV.TERM.DANF.TES 2 NL MOP 68Z3451	THERM. VALVE DANF.TES 2 NL MOP 68Z3451	VALV.TERM.DANF.TES 2 NL MOP 68Z3451	THERMOVE.DANF.TES 2 NL MOP 68Z3451
40002040	CERNIERA INOX 38x38	STEEL HINGE 38x38	BISAGRA INOX 38x38	SCHARNIER INOX 38x38
40011085	BOCCOLA INOX 304 PER PERNO SUP.PORTA	STEEL BUSH 304 FOR DOOR SUPP. PIN	CASQUILLO INOXIDABLE 304 PARA PERNO SOP. PUERTA	BUCHSE INOX 304 FÜR OB.TÜRSTIFT
40051301	VITE TCEI M14X20 C/FORO D.10 INOX	SCREW TCEI M14X20 W/HOLE D.10 STEEL	TORNILLO TCEI M14X20 C/AGUJERO D.10 INOX	SCHRAUBE TCEI M14X20 M/BOHR. D.10 INOX
40051311	BOCCOLA FILETT. INT. M14 INOX	INT. THREADED BUSH M14 STEEL	CASQUILLO ROSCADO INT. M14 INOX	INT.GEWINDEBUCHSE M14 INOX
40051330	GHIERA FISSAGGIO PIPETTA	DRAIN FIXING RING NUT	ABRAZADERA FIJACIÓN PIPETA	BEFESTIGUNGSRING PIPETTE
40051340	PIPETTA USCITA CAVO SONDA	PROBE CABLE OUTPUT DRAIN	PIPETA SALIDA CABLE SONDA	PIPETTE KABELAUS.SONDE
40071080	ASSIEME TAPPO PILETTA INOX	STEEL DRAIN CAP SET	CONJUNTO TAPÓN CONO INOX	EINHEIT DECKEL AUSLAUF INOX
40071250	MOLLA FISSAGGIO RESIST. ECO850519	FIXING HEATER SPRING	MUELLE DE FIJACIÓN RESISTENCIA	FEDER FÜR DIE HEIZUNGSBEFESTIGUNG
40080220	PIEDINO INOX 2" H. 60-80 50X70	STEEL FOOT 2" H. 60-80 50X70	PATA INOX 2" H. 60-80 50X70	FUSS INOX 2" H. 60-80 50X70
40207005	EVAPORATORE MF30.2 2008	EVAPORATOR MF30.2 2008	EVAPORADOR MF30.2 2008	VERDAMPFER MF30.2 2008
40211117	COND.ACQUA B8HX10/1P-SC-S 4*3/4"&20	WATER CONDENSER B8HX10/1P-SC-S 4*3/4"&20	COND.AGUA B8HX10/1P-SC-S 4*3/4"&20	WASSERKOND.B8HX10/1P-SC-S 4*3/4"&20
40218001	CONDENSATORE ARIA	AIR CONDENSER	CONDENSADOR AIRE	LUFTKONDENSATOR
48000033	GRIGLIA POSTERIORE MF30.2	REAR GRILL MF30.2	REJILLA POSTERIOR MF30.2	HINTERES GITTER MF30.2
68060500	PORTA SCHIUMATA SX MF30.2	LEFT SKIMMED DOOR MF30.2	PUERTA DE ESPUMA IZDA MF30.2	GESCHÄUMTE TÜR L MF30.2
68060900	FIANCO DX EVAPORATORE MF30.2	EVAPORATOR RIGHT SIDE MF30.2	COSTADO DER EVAPORADOR MF30.2	R SEITE VERDAMPFER MF30.2
68060910	FIANCO SX EVAPORATORE MF30.2	EVAPORATOR LEFT SIDE MF30.2	COSTADO IZQ EVAPORADOR MF30.2	L SEITE VERDAMPFER MF30.2

68060960	SCUDO VENTILATORI MF30.2	FANS SHIELD MF30.2	ESCUDO VENTILADORES MF30.2	LÜFTERSCHUTZ MF30.2
68061200 (2)	ASSIEME SALDATO SUPP.TEGLIA MF30.2	TRAY SUPPORT WELDED SET MF30.2	CONJUNTO SOLDADO SOP.BANDEJA MF30.2	GESCHW.EINHEIT BLECHHALTER MF30.2
68061205	ASSIEME SALDATO SUPP.TEGLIA DOPPIO MF30.2	DOUBLE TRAY SUPPORT WELDED SET MF30.2	CONJUNTO SOLDADO SOP.BANDEJA DOBLE MF30.2	GESCHW.EINHEIT DOPP.BLECHHALTER MF30.2
68140810	PIASTRINA COPERT.CRUSCOTTO MF	DASHBOARD COVER PLATE MF	PLACA COBERT.PANEL DE MANDOS MF	PLATTE ABDECKUNG TAFEL MF
68142340	STAFFA SUPP.VENTILATORE FN030	FAN SUPP. BRACKET FN030	BRIDA SOP.VENTILADOR FN030	HALTEBÜGEL LÜFTER FN030
68151273 (4)	GUIDA TEGLIE GN 2/1	TRAYS GUIDE GN 2/1	GUÍA BANDEJAS GN 2/1	BLECHFÜHR. GN 2/1
68151276 (7)	GUIDA TEGLIE PAST.	PAST. TRAYS GUIDE	GUÍA BANDEJAS PAST.	BLECHFÜHR. PAST.
270343004	VENT.ASP.A3G300 EC 200-240/50-60HZ	SUCK. FAN A3G300 EC 200-240/50-60HZ	VENT.ASP.A3G300 EC 200-240/50-60HZ	ANS.LÜFT.A3G300 EC 200-240/50-60HZ
2710220014	MOTORE VENT.M4-Q045-CF01 220-1-50	VENT. MOTOR M4-Q045-CF01 220-1-50	MOTOR VENT.M4-Q045-CF01 220-1-50	LÜFTERMOTOR M4-Q045-CF01 220-1-50
2780320038	VENTOLA ASP.D.230/28° 73811-2-3634	SUC. F AN D.230/28° 73811-2-3634	VENTILADOR ASP.D.230/28° 73811-2-3634	ANS.LÜFTER D.230/28° 73811-2-3634
4380100010	SERIGRAFIA FRONT.SCHEDA MULTI FRESH	MULTI FRESH BOARD FRONT SERIGRAPHY	SERIGRAFÍA FRONT.TARJETA MULTI FRESH	SERIGRAPHIE FRONTKARTE MULTI FRESH
4380100020	SERIGRAFIA LOGO IRINOX MULTI FRESH	MULTI FRESH IRINOX LOGO SERIGRAPHY	SERIGRAFÍA LOGO IRINOX MULTI FRESH	SERIGRAPHIE LOGO IRINOX MULTI FRESH
41M05100100	QUADRO MF30.2 230-1N-50/60	BOARD MF30.2 230-1N-50/60	CUADRO MF30.2 230-1N-50/60	TAFEL MF30.2 230-1N-50/60
41M05120100	QUADRO UC MF30.2 230-1N-50/60	BOARD UC MF30.2 230-1N-50/60	CUADRO UC MF30.2 230-1N-50/60	TAFEL UC MF30.2 230-1N-50/60
7M7052000	GRUPPO PORTA SX MF30.2	LEFT DOOR UNIT MF30.2	GRUPO PUERTA IZDA MF30.2	L TÜRGRUPPE MF30.2
8M10520000	OPZ. SUPP.TEGLIE GN2/1 MF30.2	OPT. TRAYS SUPP. GN2/1 MF30.2	OPC. SOP.BANDEJAS GN2/1 MF30.2	OPT. BLECHHALTER GN2/1 MF30.2
8M10520010	OPZ. SUPP.TEGLIE GN2/1 PAST. MF30.2	OPT. TRAYS SUPP. GN2/1 PAST. MF30.2	OPC. SOP.BANDEJAS GN2/1 PAST. MF30.2	OPT. BLECHHALTER GN2/1 PAST. MF30.2
8M10520020	OPZ. SUPP.TEGLIE DOPPIO GN1/1 MF30.2	OPT. DOUBLE TRAYS SUPP. GN1/1 MF30.2	OPC. SOP.BANDEJAS DOBLE GN1/1 MF30.2	OPT. DOPP.BLECHHALTER GN1/1 MF30.2