

Зип Общепит

DESPIECE TECNICO

vsezip.ru

+7(812)987-08-81

**Cocinas Electricas
Fourneaux Electriques
Electric Ranges
Elektro-Herde
Cucine Elettricce**

GAMA 900

Modelos:

CE 9-20

CE 9-40

CE 9-41

Enero 2007 January



Fagor Industrial

Зип Общепит

vsezip.ru

+7(812)987-08-81

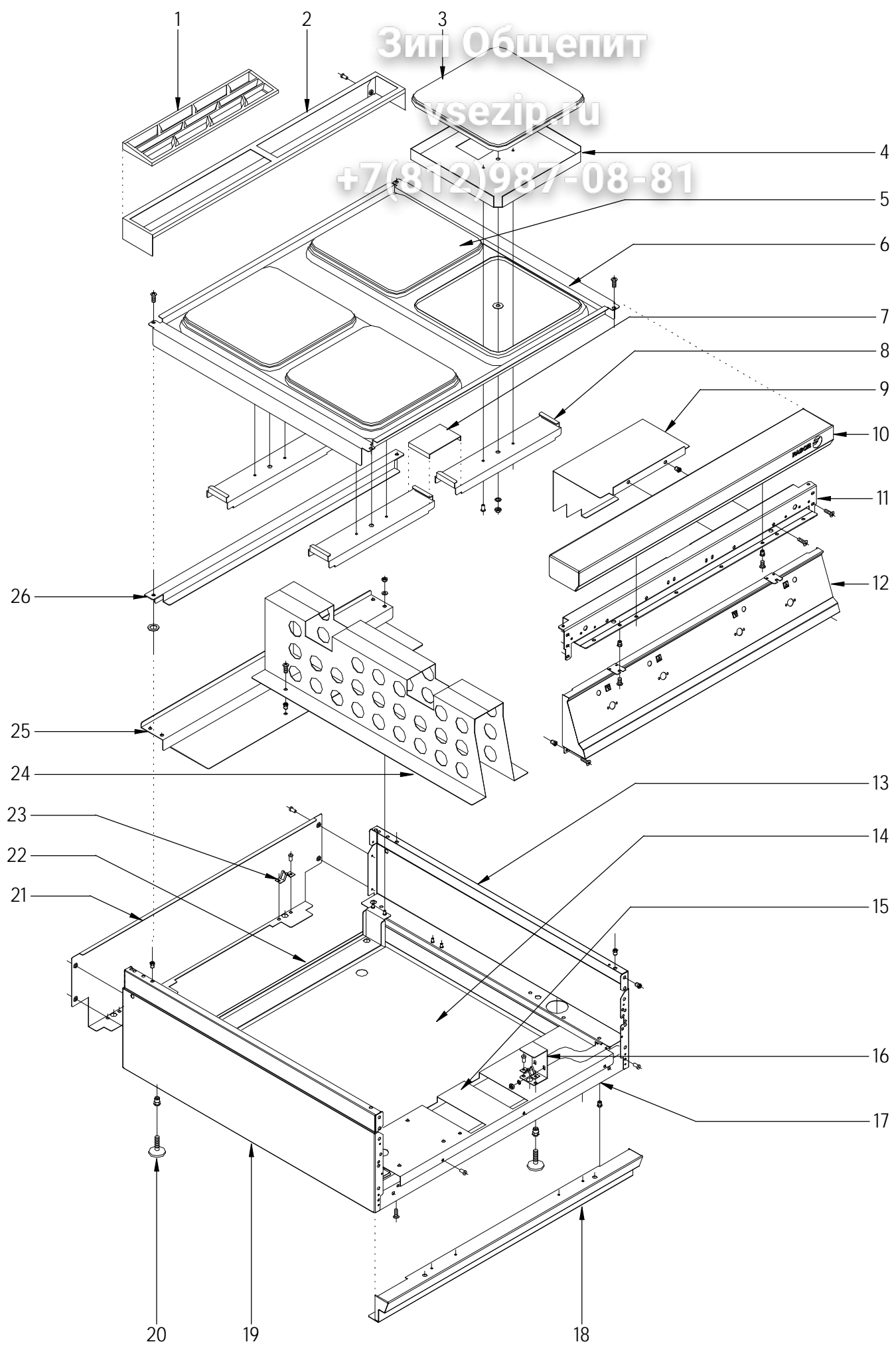

N plano	Firma	Fecha	Aparato	MUEBLE	Lamina	Fagor Industrial S.Coop. FAGOR
C-1757	<i>[Signature]</i>	2007-01	COCINA CE9-40		1	Onote

Зип Цецепит

vsezip.ru

+7(812)987-08-81

MOD.	COCINAS	ZONA	MUEBLE				
ITEM	CODIGO	DENOMINACION	TEXTO	CE9-20	CE9-40		
1	R205425000	EMBELLECEDOR ESMALTE		1	2		
2	R205428000	SOPORTE EMBELLECEDOR 1 M		1	1		
2	R205429000	SOPORTE EMBELLECEDOR 1/2 M		1	1		
	Q419005000	REMACHE 4x8 ALMG3 / ALUMINIO		2	2		
3	U673011000	PLACA 3000W 230V		1	3		
4	U675404000	CAZOLETA DE PLACAS		2	4		
	Q162050000	TUERCA EXAGONAL M8x1 INOX		2	4		
	Q262050000	ARANDELA GROW. A8 A304		2	4		
	Q232050000	ARANDELA A8		2	4		
5	U673010000	PLACA 4000W 230V		1	1		
6	U675450000	MESA DE 1M		1	1		
6	U655450000	MESA DE 1/2 M		1	1		
	Q152004000	TORNIL, APLASTADO M5x13 A304		4	4		
7	U675455000	APOYO PUENTE AMARRE PLACAS		1	2		
8	U655404000	PUENTE AMARRE PLACAS		2	4		
9	U802602000	CHAPA PROTEC.CONMUTADORAS		1	2		
	Q152004000	TORNIL, APLASTADO M5x13 A304		4	4		
	Q221341000	REMACHE EXAGONAL M 4		1	1		
10	U025426000	ANTERIOR DE MESA 1 M		1	1		
10	R045411000	ANTERIOR DE MESA 1/2 M		1	1		
	Q152004000	TORNIL, APLASTADO M5x13 A304		2	2		
	Q302022000	ARANDELA 16x6x1,2 A304		2	2		
11	U022605000	ESCUADRA INTER. ANT. MESA 1M		1	1		
11	X162680000	ESCUADRA INTE. ANT. MESA 1/2M		1	1		
	Q221342000	REMACHE EXAGONAL M5		3	2		
	Q152004000	TORNIL, APLASTADO M5x13 A304		6	6		
	Q221343000	REMACHE EXAGONAL M6		2	2		
	Q302022000	ARANDELA 16x6x1,2 A304		4	4		
	Q221342000	REMACHE EXAGONAL M5		4	4		

Зип Общепит

vsezip.ru

+7(812)987-08-81

MOD.		COCINAS	ZONA	MUEBLE			
ITEM	CODIGO	DENOMINACION	TEXTO	CE9-20	CE9-40		
12	U172804000	PORTAMANDOS CE9-41		1	1		
12	U142800000	PORTAMANDOS CE9-20		1	1		
	Q152004000	TORNIL, APLASTADO M5x13 A304		2	2		
13	R062810000	PANEL LATERAL DERECHO		1	1		
	Q221343000	REMACHE EXAGONAL M6		5	5		
	Q221342000	REMACHE EXAGONAL M5		2	2		
	Q221342000	REMACHE EXAGONAL M5		3	3		
14	U662850000	BASE INFERIOR CE9-40		1	1		
14	U652820000	BASE INFERIOR CE9-20		1	1		
	Q152004000	TORNIL, APLASTADO M5x13 A304		4	2		
	Q302022000	ARANDELA 16x6x1,2 A304		4	1		
	Q419007000	REMACHE TUBULAR C/V D3.2X6		1	8		
15	U672652000	ESCUADRA SOPOR. REGLETA CE		1	1		
15	U652650000	ESCUADRA SOPOR. REGLETA CE		1	1		
	Q419005000	REMACHE 4x8 ALMG3 / ALUMINIO		3	3		
16	H012805000	ESCUADRA AMARRE PATA		2	2		
	Q162030000	TUERCA EXAGONAL M5		4	4		
	Q302022000	ARANDELA 16x6x1,2 A304		4	4		
17	H022604000	LISTON AMARRE ZOCALO		1	1		
17	U652651000	LISTON AMARRE ZOCALO 1/2M		1	1		
	Q419005000	REMACHE 4x8 ALMG3 / ALUMINIO		4	4		
	Q221342000	REMACHE EXAGONAL M5		4	4		
18	R392805000	ZOCALO COMPLETO		1	1		
18	R062805000	ZOCALO COMPLETO 1/2M		1	1		
	Q151336000	TORNILLO SOPORTE GUIAS		2	2		
	Q221343000	REMACHE EXAGONAL M6		2	2		
	Q152004000	TORNIL, APLASTADO M5x13 A304		2	2		
	Q302022000	ARANDELA 16x6x1,2 A304		2	2		

Зип Ощепит

vsezip.ru

+7(812)987-08-81

MOD.	COCINAS	ZONA	MUEBLE				
ITEM	CODIGO	DENOMINACION	TEXTO	CE9-20	CE9-40		
19	R062811000	PANEL LATERAL IZQUIERDO		1	1		
	Q221343000	REMACHE EXAGONAL M6		5	5		
	Q221342000	REMACHE EXAGONAL M5		2	2		
	Q221342000	REMACHE EXAGONAL M5		3	3		
20	Z200107000	PATA REGULABLE		4	4		
	Q221345000	REMACHE EXAGONAL M10		4	4		
21	R162813000	PANEL POSTERIOR		_	1		
21	R152811000	PANEL POSTERIOR 1/2M		1	_		
	Q419005000	REMACHE 4x8 ALMG3 / ALUMINIO		4	4		
22	H022606000	REFUERZO POSTERIOR PATAS		_	1		
22	H012606000	REFUERZO POSTER. PATAS 1/2M		1	_		
	Q162030000	TUERCA EXAGONAL M5		4	4		
	Q302022000	ARANDELA 16x6x1,2 A304		4	4		
	Q221345000	REMACHE EXAGONAL M10		4	4		
23	X010503000	CIERRE MUELLE		3	4		
24	U675451000	SOPORTE MESA CE9-40/41		_	1		
	Q152004000	TORNIL, APLASTADO M5x13 A304		_	2		
25	U662650000	TRAVESAÑO SOP. MESA CE9-40		_	1		
	Q221342000	REMACHE EXAGONAL M5		_	2		
26	U675456000	REFUERZO POSTERIOR DE MESA		_	1		
	Q301322000	ARANDELA PLANA 27x17x2		_	4		

Зип Общепит

vsezip.ru

+7(812)987-08-81

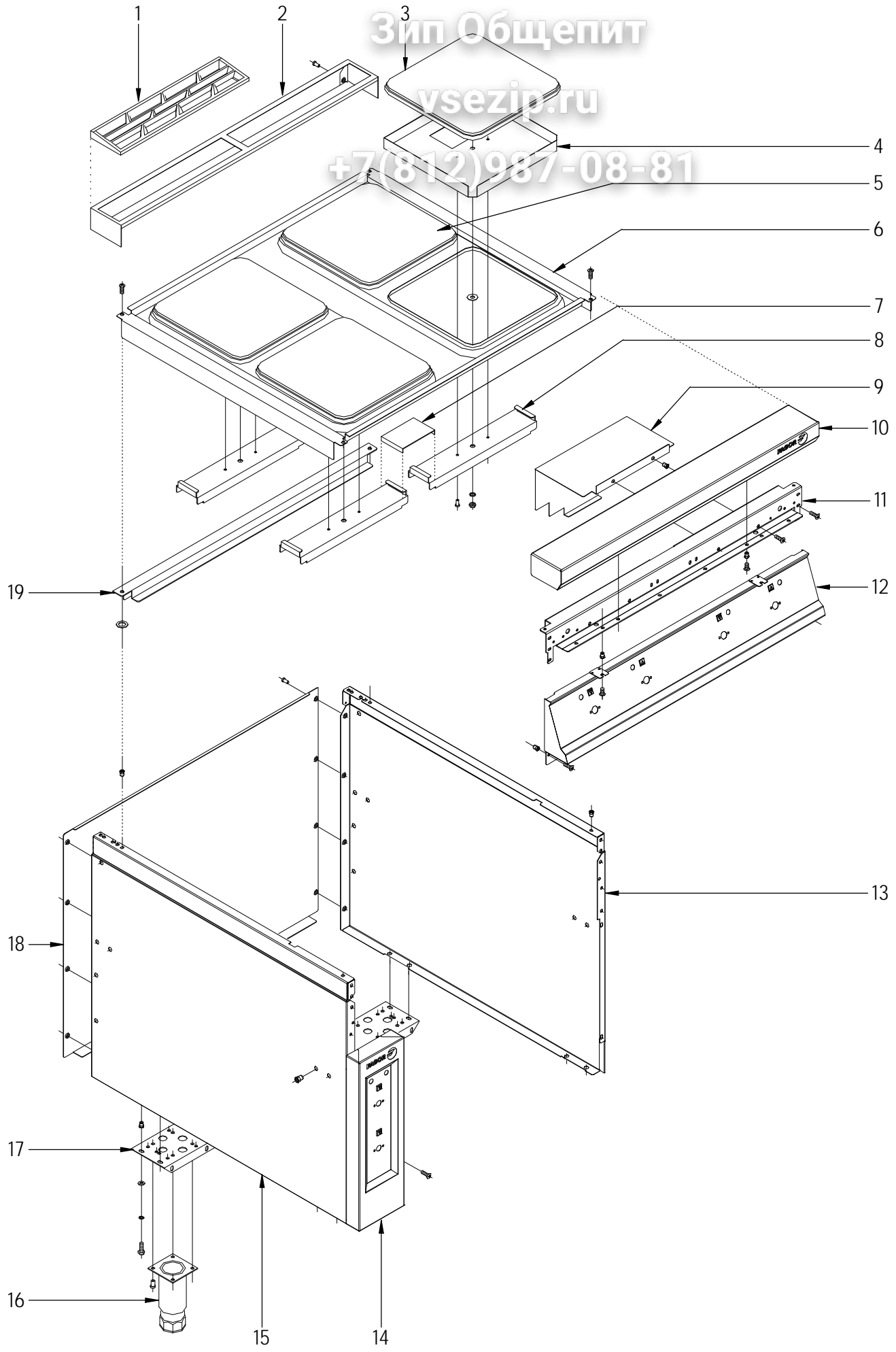

N plano	Firma	Fecha	Aparato	MUEBLE	Lamina	Fagor Industrial S.Coop. FAGOR
C-1758	<i>Firma</i>	2007-01	COCINA CE9-41		2	Onote

Зип Общепит

vsezip.ru

+7(812)987-08-81

MOD.		COCINAS	ZONA	MUEBLE			
ITEM	CODIGO	DENOMINACION	TEXTO	CE9-41			
1	R205425000	EMBELLECEDOR ESMALTE		2			
2	R205428000	SOPORTE EMBELLECEDOR 1 M		1			
	Q419005000	REMACHE 4x8 ALMG3 / ALUMINIO		2			
3	U673011000	PLACA 3000W 230V		3			
4	U675404000	CAZOLETA DE PLACAS		4			
	Q162050000	TUERCA EXAGONAL M8x1 INOX		4			
	Q262050000	ARANDELA GROW. A8 A304		4			
	Q232050000	ARANDELA A8		4			
5	U673010000	PLACA 4000W 230V		1			
6	U675450000	MESA DE 1M		1			
	Q152004000	TORNIL, APLASTADO M5x13 A304		4			
7	U675455000	APOYO PUENTE AMARRE PLACAS		2			
8	U655404000	PUENTE AMARRE PLACAS		4			
9	U802602000	CHAPA PROTEC.CONMUTADORAS		2			
	Q152004000	TORNIL, APLASTADO M5x13 A304		4			
	Q221341000	REMACHE EXAGONAL M 4		1			
10	U025426000	ANTERIOR DE MESA 1 M		1			
	Q152004000	TORNIL, APLASTADO M5x13 A304		2			
	Q302022000	ARANDELA 16x6x1,2 A304		2			
11	U022605000	ESCUADRA INTERIOR ANT. MESA		1			
	Q221342000	REMACHE EXAGONAL M5		2			
	Q152004000	TORNIL, APLASTADO M5x13 A304		6			
	Q221343000	REMACHE EXAGONAL M6		2			
	Q302022000	ARANDELA 16x6x1,2 A304		4			
	Q221342000	REMACHE EXAGONAL M5		4			
12	U172804000	PORTAMANDOS CE9-41		1			
	Q152004000	TORNIL, APLASTADO M5x13 A304		2			

Зип Общепит

vsezip.ru

+7(812)987-08-81

MOD.		COCINAS	ZONA	MUEBLE			
ITEM	CODIGO	DENOMINACION	TEXTO	CE9-41			
13	U022819000	PANEL LATERAL DERECHO		1			
	Q221343000	REMACHE EXAGONAL M6		4			
	Q221343000	REMACHE EXAGONAL M6		5			
	Q221342000	REMACHE EXAGONAL M5		2			
	Q221342000	REMACHE EXAGONAL M5		3			
	Q221342000	REMACHE EXAGONAL M5		1			
	Q012043000	TORNILLO EXAGONAL M6x20 A304		4			
	Q302022000	ARANDELA 16x6x1,2 A304		4			
	Q152004000	TORNIL, APLASTADO M5x13 A304		2			
14	U672854000	POTAMANDOS LATERAL HORNO		1			
	Q152004000	TORNIL, APLASTADO M5x13 A304		2			
15	X162813000	PANEL LATERAL IZQUIERDO		1			
	Q221343000	REMACHE EXAGONAL M6		4			
	Q221343000	REMACHE EXAGONAL M6		5			
	Q221342000	REMACHE EXAGONAL M5		2			
	Q221342000	REMACHE EXAGONAL M5		3			
	Q221342000	REMACHE EXAGONAL M5		1			
	Q012043000	TORNILLO EXAGONAL M6x20 A304		4			
	Q302022000	ARANDELA 16x6x1,2 A304		4			
	Q152004000	TORNIL, APLASTADO M5x13 A304		2			
16	X260151000	PATA REGULABLE		4			
	Q411304000	REMACHE AVIBULB Ø 4,8		16			
17	U022607000	LISTON SOPORTE PATAS 1 M		2			
	Q012043000	TORNILLO EXAGONAL M6x20 A304		4			
	Q302022000	ARANDELA 16x6x1,2 A304		4			
18	U562853000	PANEL POSTERIOR		1			
	Q419005000	REMACHE 4x8 ALMG3 / ALUMINIO		8			
19	U675456000	REFUERZO POSTERIOR DE MESA		1			

Зип Общепит

vsezip.ru

+7(812)987-08-81

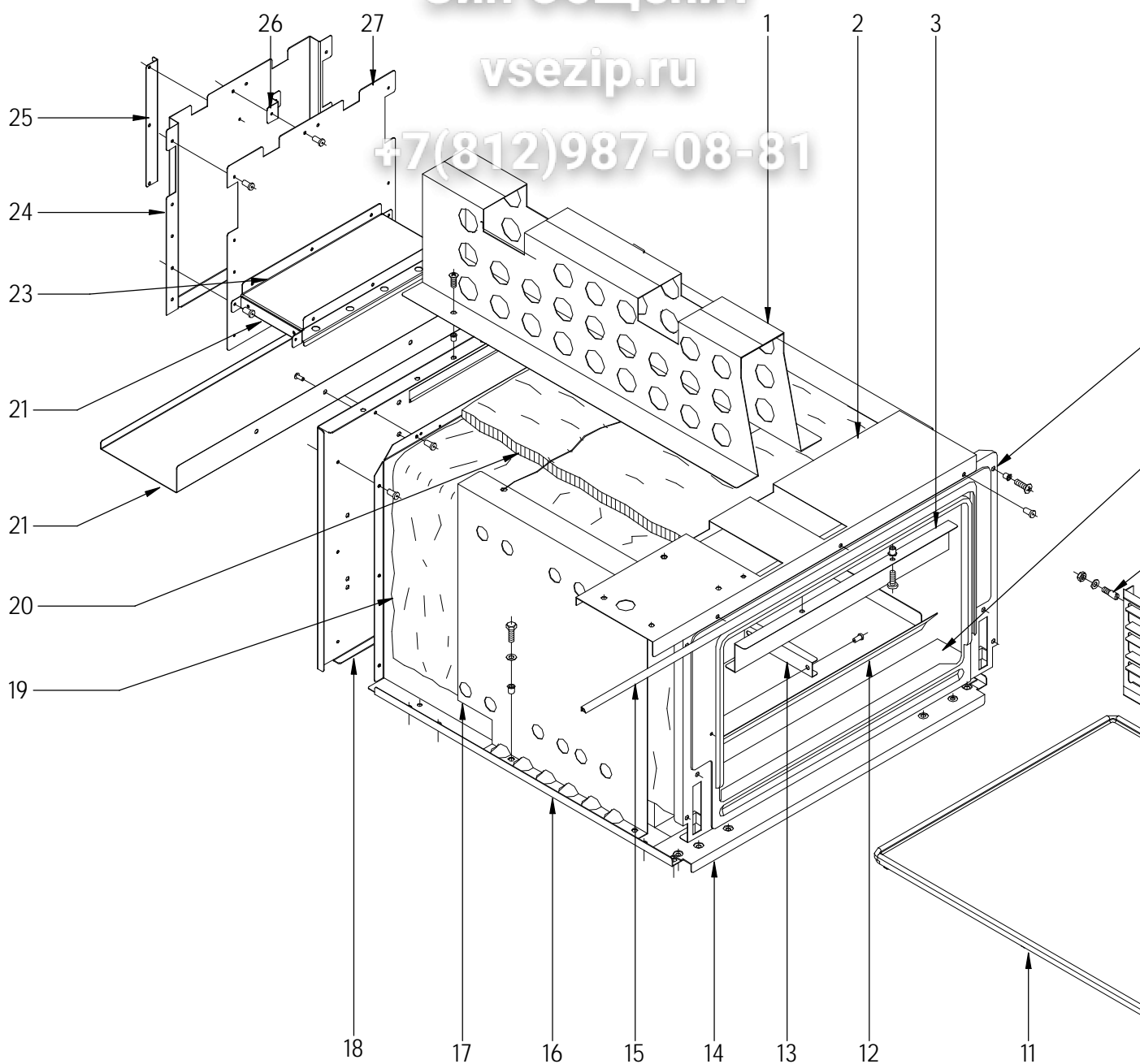

Modello	C-1759
Firma	
Fecha	2007-01
Apelativo	HORNO
Modello	COCINA CE9-41
Lamina	3
Orfite	Fagor Industrial S. Coop.

Зип Общепит

vsezip.ru

+7(812)987-08-81

MOD.	COCINAS	ZONA	HORNO				
ITEM	CODIGO	DENOMINACION	TEXTO	CE9-41			
1	U675451000	SOPORTE MESA CE9-40/41		1			
	Q152004000	TORNIL, APLASTADO M5x13 A304		2			
2	U672652000	ESCUADRA SOPORTE REGLETA		1			
	Q419005000	REMACHE 4x8 ALMG3 / ALUMINIO		3			
3	U805609000	AMARRE SOPORTE SUPERIOR		1			
	Q152004000	TORNIL, APLASTADO M5x13 A304		2			
4	U025629000	MARCO COMPLETO INOX		1			
5	U175603000	CIERRE ANTERIOR HORNO		1			
6	Q151336000	TORNILLO SOPORTE GUIAS		4			
	Q302022000	ARANDELA 16X6X1.2 A.304		8			
	Q162040000	TUERCA EXAGONAL M6		4			
7	U025613000	GUIA BANDEJAS		2			
8	U325611000	ESC. GUIA SOPORT BANDEJAS		2			
	Q412000000	REMACHE TUBULAR 4x8		4			
9	Q151336000	TORNILLO SOPORTE GUIAS		4			
	Q412000000	REMACHE TUBULAR 4x8		7			
10	U025611000	TAPA PEQUENA PLACA HORNO		1			
11	U025610000	PLACA HORNO		1			
S/N	U135642000	PARRILLA DE HORNO		1			
12	U805606000	BASE HORNO ELÉCTRICO		1			
	Q152004000	TORNIL, APLASTADO M5x13 A304		4			
13	U055644000	CONJUNTO FIJACION BULBO		1			
	Q412000000	REMACHE TUBULAR 4x8		2			
14	U025609000	REFUERZO ANTER HORNO		1			
	Q412002000	REMACHE AVINOX Ø4x10mm		32			
	Q221321000	REMACHE ROSCAD. NUTSERT M6		4			
	Q221304000	REMACHE ROSCAD. NUTSERT M5		4			
	Q221304000	REMACHE ROSCAD. NUTSERT M5		4			
15	U025623000	JUNTA PUERTA HORNO		1			
16	U175601000	CUERPO DE HORNO ELECTRICO		1			

Зип Общепит

vsezip.ru

+7(812)987-08-81

MOD.		COCINAS	ZONA	HORNO			
ITEM	CODIGO	DENOMINACION	TEXTO	CE9-41			
17	U802601000	SUJECCION AISLANTE		2			
	Q152004000	TORNIL, APLASTADO M5x13 A304		4			
	Q221342000	REMACHE EXAGONAL M5		4			
18	U175606000	POSTERIOR HORNO ELECTRICO		1			
19	U325621000	AISLANTE 1455x670x20-AL1C		1			
20	U805605000	AISLANTE 670x560x20-AL1C		1			
21	U562656000	EVACUACION CALOR DE HUMOS		1			
	Q152004000	TORNIL, APLASTADO M5x13 A304		2			
22	U565610000	UNION CHIMENEA INFERIOR		1			
23	U565609000	UNION CHIMENEA SUPERIOR		1			
24	U745606000	POSTERIOR DE CHIMENEA		1			
	Q419005000	REMACHE 4x8 ALMG3 / ALUMINIO		8			
25	U565611000	DISTANCIADOR DE CHIMENEA		1			
	Q419005000	REMACHE 4x8 ALMG3 / ALUMINIO		9			
26	U745607000	DISTANCIADOR CHIMENEA		1			
	Q419005000	REMACHE 4x8 ALMG3 / ALUMINIO		2			
27	U745605000	ANTERIOR DE CHIMENEA		1			

Зип Общепит

vsezip.ru

+7(812)987-08-81

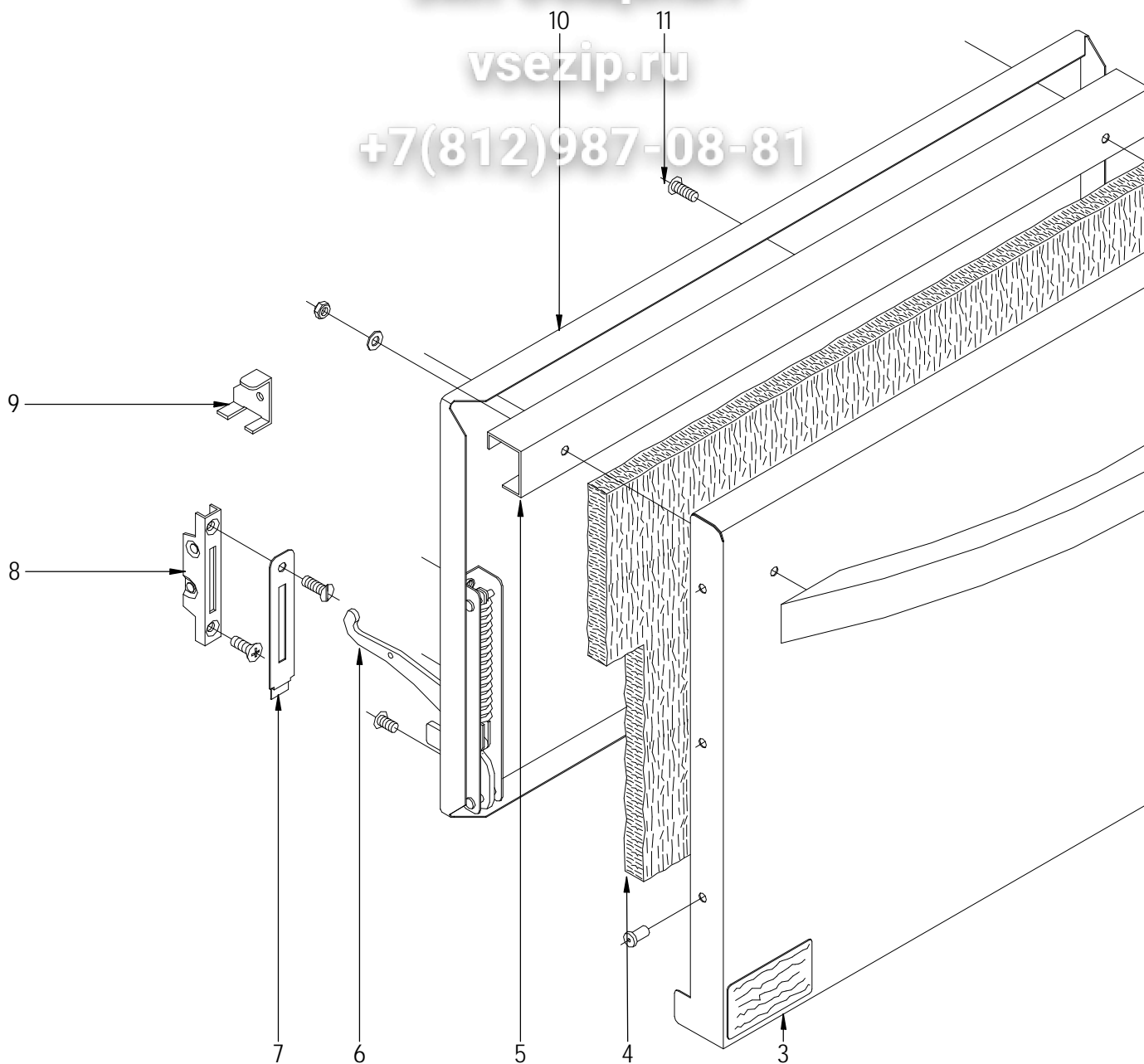

N. plano	Firma	Fecha	Aparato	Lamina	Fagor Industri al s. Coop. FAGOR Orfite
C-1760		2007-01	COCINA CE9-41	4	
			PUERTA HORNO		

Зип Общепит

vsezip.ru

+7(812)987-08-81

MOD.		COCINAS	ZONA	PUERTA HORNO			
ITEM	CODIGO	DENOMINACION	TEXTO	CE9-41			
1	U020504000	ASA DE HORNO COMPLETA G900		1			
	Q302022000	ARANDELA 16X6X1.2 A.304		2			
	Q162040000	TUERCA EXAGONAL M6		2			
2	U020519000	PUERTA DE HORNO		1			
3	S326320000	PAPEL POLYESTER 89x49		1			
4	U260502000	AISLANTE 680x380x20		1			
5	U320507000	REFUERZO DE PUERTA		1			
6	U010511000	BISAGRA IZQUIERDA		1			
S/N	U010504000	BISAGRA DERECHA		1			
	Q152022000	TORNILLO M6x8		6			
7	U010510000	EMBELLECEDOR GUIA BISAGRA		2			
	Q152017000	TORNILLO AMARRE M6x13 A304		2			
8	U010512000	GUIA BISAGRA		2			
	Q042043000	TORNILLO AVELLANADO M6x20		2			
9	U746501000	ESCUADRA MONTAJE PUERTA		2			
10	U020522000	CONTRAPUERTA HORNO		1			
11	Q152017000	TORNILLO AMARRE M6x13 A304		3			
	Q412000000	REMACHE TUBULAR 4x8		6			

Зип Общепит

vsezip.ru

+7(812)987-08-81

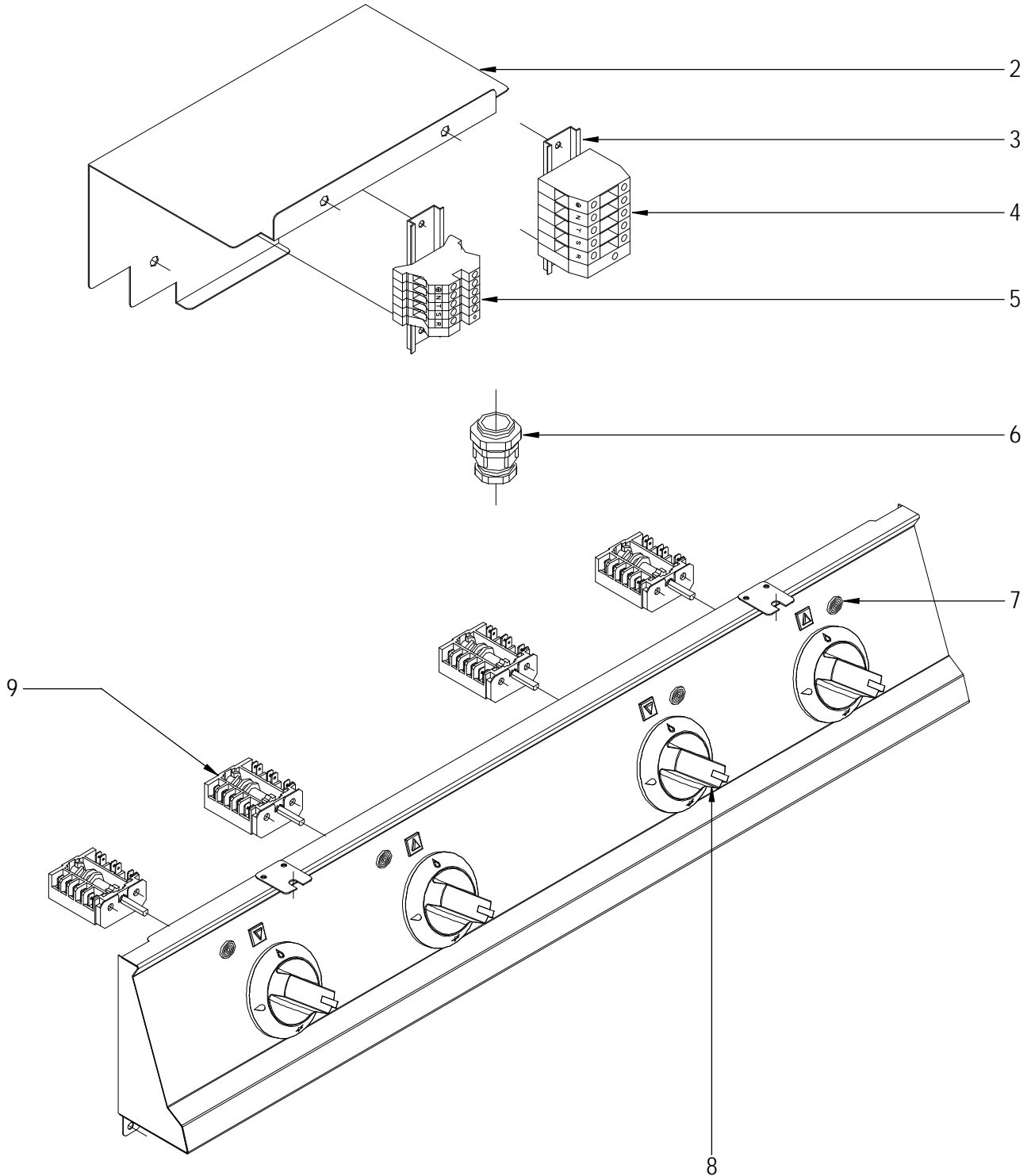

N plano	Firma	Fecha	Aparato	PARTE FUNCIONAL	Lamina	Fagor Industrial S.Coop. FAGOR
C-1761	<i>[Signature]</i>	2007-01	COCINA CE9-40	5	Oñate	

Зип Общепит

vsezip.ru

+7(812)987-08-81

MOD.	COCINAS	ZONA	PARTE FUNCIONAL ELECTRICA				
ITEM	CODIGO	DENOMINACION	TEXTO	CE9-20	CE9-40		
1	U673011000	PLACA 3000W 230V		1	3		
1	U673012000	PLACA 3000W 400V SIN NEUTRO		1	3		
1	U673010000	PLACA 4000W 230V		1	1		
1	U673013000	PLACA 4000W 400V SIN NEUTRO		1	1		
2	U802602000	CHAPA PROTEC.CONMUTADORAS		1	2		
	Q152004000	TORNIL, APLASTADO M5x13 A304		4	4		
	Q221341000	REMACHE EXAGONAL M 4		1	1		
3	R663055000	GUIA CONTACTOR L-120		1	1		
	Q419005000	REMACHE 4x8 ALMG3 / ALUMINIO		2	4		
4	R263003000	BORNA PASO 35 MM.		—	3		
	R673010000	BORNA PASO AZUL 35 MM.		—	1		
	Z103035000	BORNA TIERRA 35 MM.		—	1		
	Z683096000	TOPE FINAL WEW35 10590.0		—	1		
	Z683068000	SEÑALIZ.DEK-6 WEIDMULLER		—	1		
5	P453025000	BORNES 10 WDU-10203.0		3	—		
	Z263302000	BORNA PASO AZUL		1	—		
	P453026000	BORNA TIERRA 10 WPE-10103.3		1	—		
	Z263303000	TOPE FINAL		1	—		
	Z683068000	SEÑALIZ.DEK-6 WEIDMULLER		1	—		
6	R023013000	PRENSA ESTOPAS		1	1		
	R023025000	CONTRATUERCA (GAES)		1	1		
	R023026000	JUNTA DE GOMA (GAES)		1	1		
7	R693056000	PILOTO AMBAR		2	4		
8	U173007000	BOTON DE MANDO Ø 6		2	4		
9	U673007000	CONMUTADOR EGO		2	4		
	Q151320000	TORNILLO ALOMADO M4x6 H.ZINC.		4	8		

Зип Общежит

vsezip.ru

+7(812)987-08-81

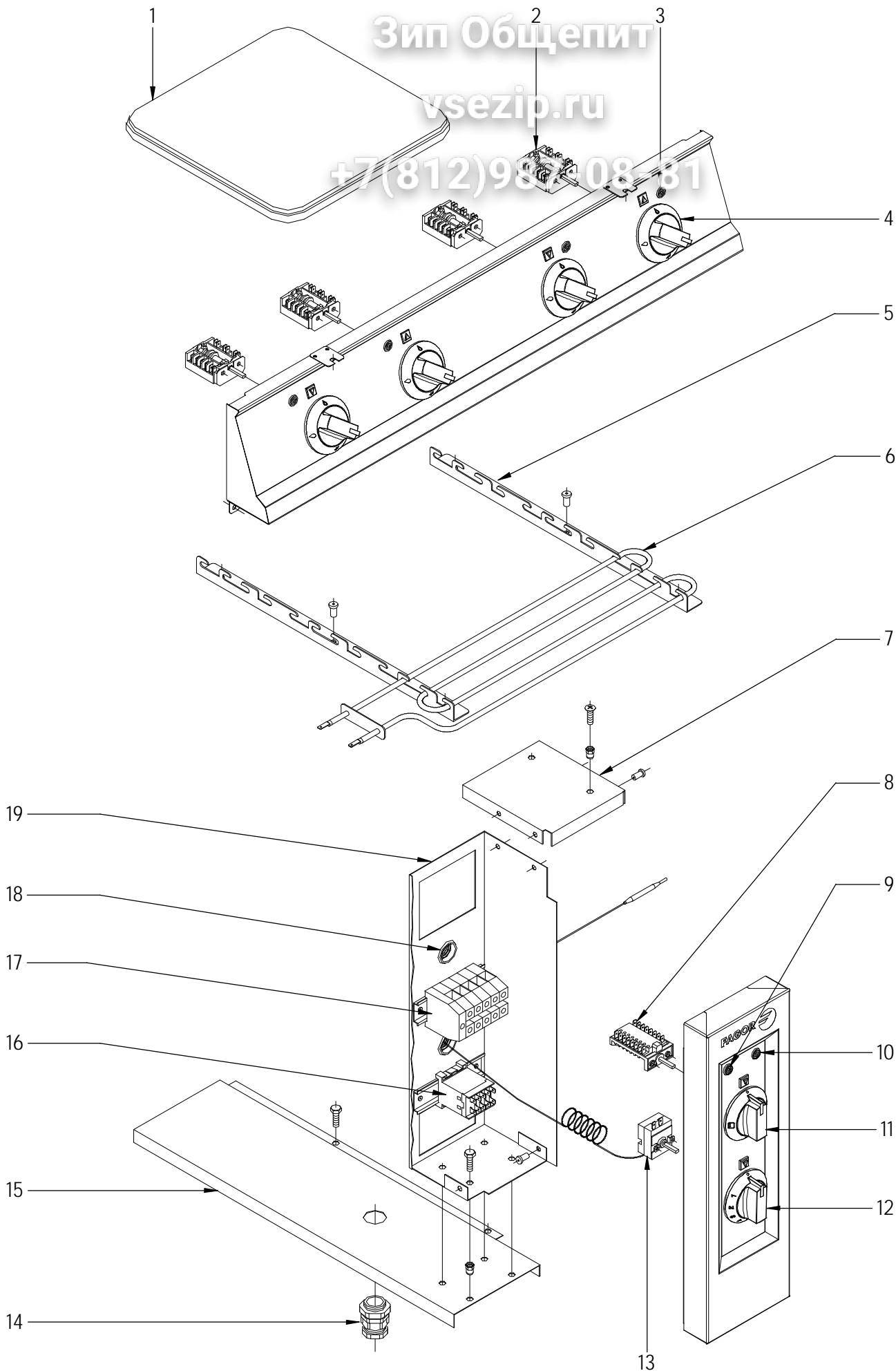

N plano	Firma	Fecha	Aparato	PARTE FUNCIONAL	Lamina	Fagor Industrial S.Coop. FAGOR
C-1762	<i>[Signature]</i>	2007-01	COCINA CE9-41		6	Oñate

Зип Общепит

vsezip.ru

+7(812)987-08-81

MOD.		COCINAS	ZONA	PARTE FUNCIONAL ELECTRICA			
ITEM	CODIGO	DENOMINACION	TEXTO	CE9-41			
1	U673011000	PLACA 3000W 230V		3			
1	U673012000	PLACA 3000W 400V SIN NEUTRO		3			
1	U673010000	PLACA 4000W 230V		1			
1	U673013000	PLACA 4000W 400V SIN NEUTRO		1			
2	U673007000	CONMUTADOR EGO		4			
	Q151320000	TORNILLO ALOMADO M4x6 H.ZINC.		8			
3	R693056000	PILOTO AMBAR		4			
4	U173007000	BOTON DE MANDO Ø 6		4			
5	U805613000	ESCUADRA SOPOR. RESISTENCIAS		4			
	Q419005000	REMACHE 4x8 ALMG3 / ALUMINIO		2			
6	U803004000	RESISTENCIA 1000W/230V		6			
7	U673051000	TAPA DE CUADRO ELECTRICO		1			
	Q419005000	REMACHE 4x8 ALMG3 / ALUMINIO		2			
	Q419005000	REMACHE 4x8 ALMG3 / ALUMINIO		4			
	Q221342000	REMACHE EXAGONAL M5		2			
	Q012032000	TORNILLO EXAGONAL M5x15 A304		2			
	Q012032000	TORNILLO EXAGONAL M5x15 A304		2			
8	U673006000	CONMUTADOR		1			
	Q151320000	TORNILLO ALOMADO M4x6 H.ZINC.		2			
9	R693055000	PILOTO VERDE 41227000C7		1			
10	R693056000	PILOTO AMBAR		1			
11	U173006000	BOTON DE MANDO Ø6 CONMUTAD.		1			
12	U173005000	BOTON DE MANDO Ø6 TERMOSTA.		1			
13	X153000000	TERMOSTATO 50-310º C		1			
	Q151320000	TORNILLO ALOMADO M4x6 H.ZINC.		2			
14	R023013000	PRENSA ESTOPAS		1			
	R023025000	CONTRATUERCA (GAES)		1			
	R023026000	JUNTA DE GOMA (GAES)		1			
15	U672650000	PROTEC. INFERIOR RESISTENCIAS		1			
	Q012031000	TORNILLO EXAGONAL M5x10 A304		2			

Зип Общепит

vsezip.ru

+7(812)987-08-81

MOD.		COCINAS		ZONA	PARTE FUNCIONAL ELECTRICA			
ITEM	CODIGO	DENOMINACION	TEXTO	CE9-41				
16	Z213007000	CONTACTOR 3TF2010-3AL2		1				
	R663055000	GUIA CONTACTOR L-120		1				
	Q419005000	REMACHE 4x8 ALMG3 / ALUMINIO		4				
17	R263003000	BORNA PASO 35 MM.		3				
	R673010000	BORNA PASO AZUL 35 MM.		1				
	Z103035000	BORNA TIERRA 35 MM.		1				
	Z683096000	TOPE FINAL WEW35 10590.0		1				
	Z683068000	SEÑALIZ.DEK-6 WEIDMULLER		1				
	R663055000	GUIA CONTACTOR L-120		1				
18	X723014000	PASAMUROS AMETRO 30		2				
19	U673050000	CUADRO ELECTRICO		1				

Зип Общепит

vsezip.ru

+7(812)987-08-81

MOD.		COCINAS		ZONA	VARIOS		
ITEM	CODIGO	DENOMINACION	TEXTO	CE9-20	CE9-40	CE9-41	
	U676550000	FOLLETO DE INSTRUC. CE9-00		1	1	1	
	U653001000	ESQUEMA TEORICO ADHESIVO		1			
	U663000000	ESQUEMA TEORICO ADHESIVO			1		
	U673001000	ESQUEMA TEORICO ADHESIVO				1	
	U653003000	CABLEADO PORTAMANDOS MESA		1			
	U673052000	CABLEADO PORTAMANDOS MESA			1	1	
	U673014000	CABLEADO A PLACAS		2	4	4	
	U673008000	CABLEADO HORNO				1	

Зип Общепит

vsezip.ru

+7(812)987-08-81

MOD.		COCINAS		ZONA	PIEZAS ESPECIFICAS PARA LOS DIST VOLTAJES			
ITEM	CODIGO	DENOMINACION	TEXTO	CE9-20	CE9-40	CE9-41		
<u>VERSION: 220 / 240 / 380 / 415 V (CON NUETRO)</u>								
1	U673011000	PLACA 3000W 230V		1	3	3		
1	U673010000	PLACA 4000W 230V		1	1	1		
<u>VERSION: 440 V (SIN NUETRO)</u>								
1	U673012000	PLACA 3000W 400V		1	3	3		
1	U673013000	PLACA 4000W 400V		1	1	1		
S/N	U803072000	RESISTENCIA 150K, 1/4W		2	4	6		
S/N	U803073000	RESISTENCIA 8K2, 6W		-	-	1		

Зип Общепит

vsezip.ru

+7(812)987-08-81

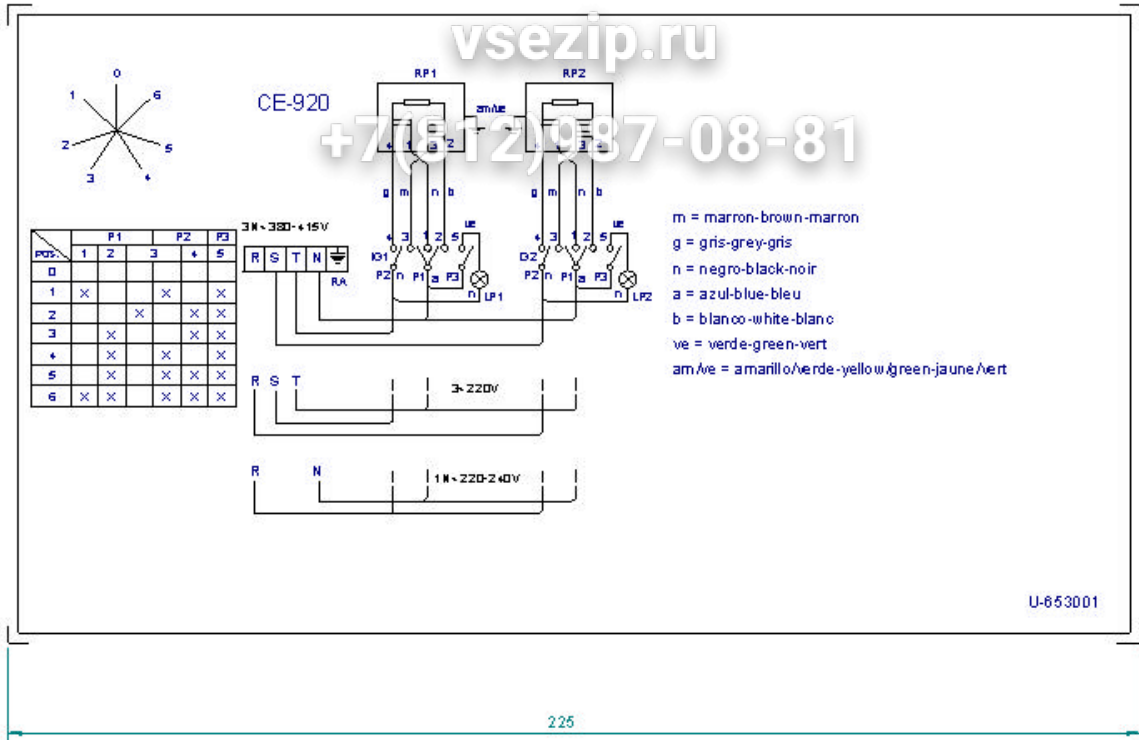

U-653001

NOTA

- Las inscripciones resistirán a la modificación apreciable e infortunada durante 15 seg. de la algodón impregnado en gasolina.

- RA: Regleta de Alimentación
- IG1, IG2: Conmutadores de placas eléctricas
- RP1, RP2: Placas eléctricas
- LP1, LP2: Lámpara Calentamiento de Placas

Plastico B

Esquema teorico		
N°	Pieza	Canl.
N°	Modificacion	
Firma		Fecha
Dibujado	Plazaola	21-4-97
Proyectado		
Comprobado		Fagor In
Escala	1/1	
		COCINAS
Falso hueco a colarse en el interior de la cocina para la instalación de gas		

Зип Общепит

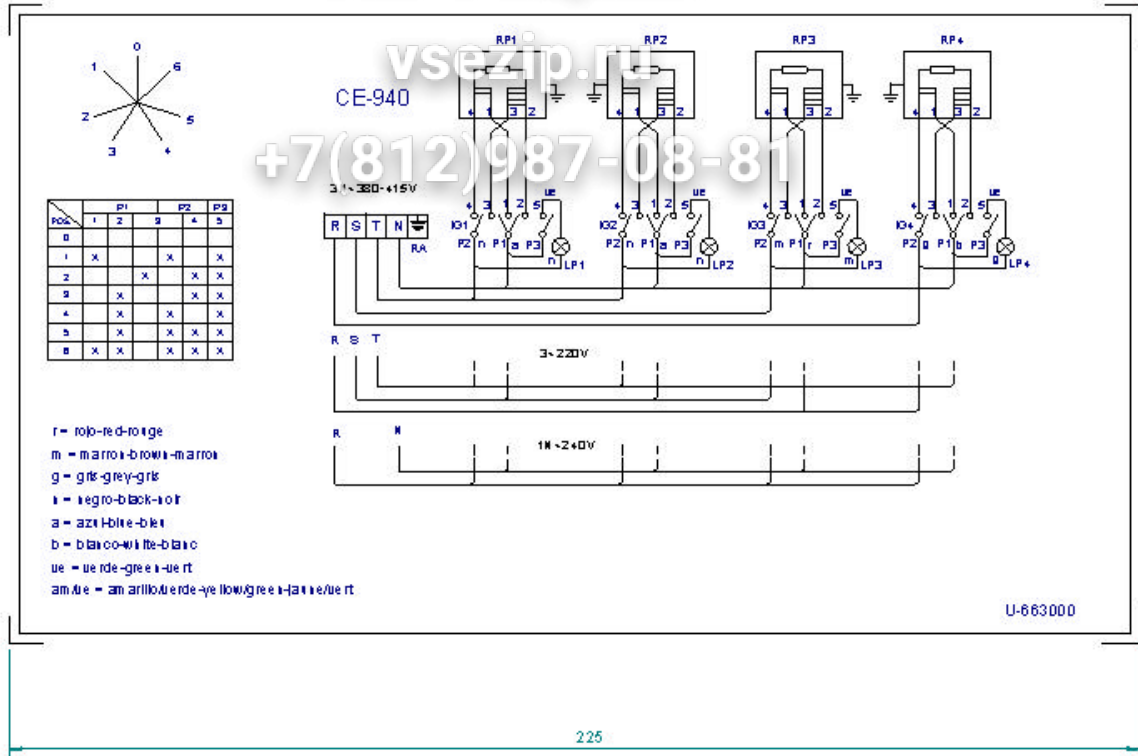

NOTA

- Las inscripciones resistirán sin modificación apreciable el frotamiento durante 15 seg. de un algodón impregnado en gasolina.

RA: Regleta de Alimentación

IG1, IG2, IG3, IG4: Conmutadores de placas eléctricas

RP1, RP2, RP3, RP4: Placas eléctricas

LP1, LP2, LP3, LP4: Lámpara Calentamiento de Placas

Esquema teórico		
N°	Pieza	Canl.
N°	Modificación	
Firma		Fecha
Dibujado	Plazaola	22-4-97
Proyectado		
Comprobado		
Escala	1/1	
		FAO
		Fabor In
		COCINAS
Firma y sello de cada emisor. Verificar que no haya errores.		

Зип Общепит

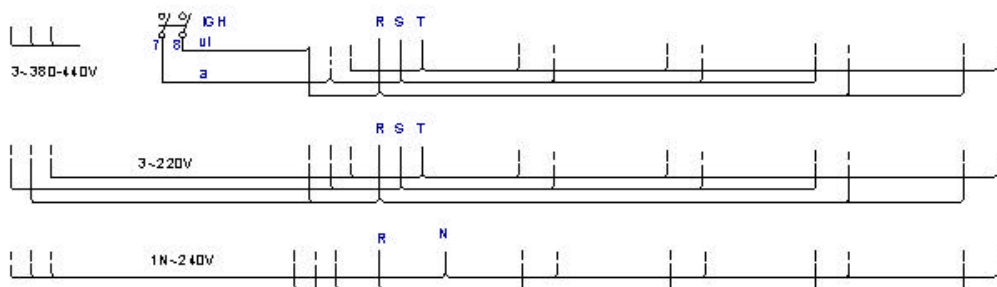
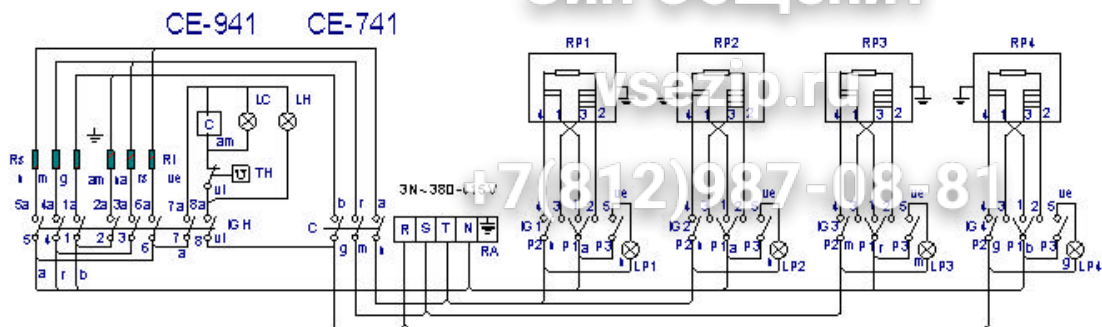

	1_2	3_4	5_6	7	8
	1a	2a	3a	4a	5a
0					
1	X		X	X	X
2	X	X	X	X	X
3	X	X		X	X

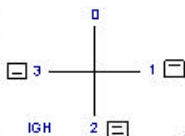

U-673001

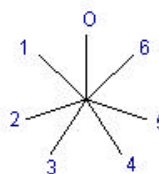

IG POS.	P1		P2		P3	
	1	2	3	4	5	6
1	X			X	X	
2		X		X	X	
3	X			X	X	
4	X		X	X		
5	X		X	X		
6	X	X		X	X	

- RA:Regleta de Alimentacion
- IGH :Conmutador General Horno
- C: Contactor
- LC : Lampara Calentamiento Horno
- LH: Lampara Horno Encendido
- TH : Termostato de Horno
- Rs : Resistencia Horno Superior
- Ri : Resistencia Horno Inferior
- IG,IG2,IG3,IG4 : Conmutadores de Horno
- RP1,RP2,RP3,RP4:P lacas electricas
- LP1,LP2,LP3,LP4:Lampara Calentamiento Horno
- TFR: Transformador

- r = rojo-red-rouge
- m = marron-brown-marron
- g = gris-grey-gris
- n = negro-black-noir
- a = azul-blue-bleu
- b = blanco-white-blanc
- vi = violeta-violette-violet
- am = amarillo-yellowjaune
- na = naranja-orange-orange
- rs = rosa-rose-pink
- ve = verde-green-vert
- am/ve = amarillo/verde-yellow/green

Esquema teorico adhesivo		
N°	Pieza	Canl.
N°	Modificador	
Dibujado		Firma
Proyectado		Impugnada
Comprobado		Fecha
Escala		
1/1		31/05/05
		FAG
		Favor In
		COCINAS
Placa has sido distribuida en todos los puntos de venta de la marca		

Зип Общепит

vsezip.ru

+7(812)987-08-81

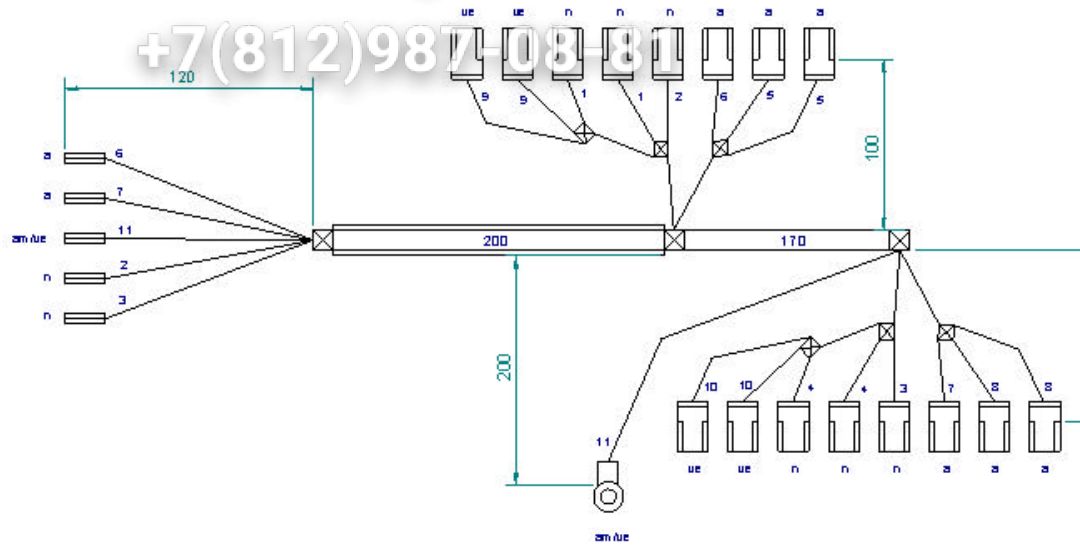

N°	Color	mm ²	Longitud	Material
1	Negro	0.75	150	Silicona
2	Negro	2.5	420	Silicona
3	Negro	2.5	590	Silicona
4	Negro	0.75	150	Silicona
5	Azul	0.75	60	Silicona
6	Azul	2.5	420	Silicona
7	Azul	2.5	590	Silicona
8	Azul	0.75	60	Silicona
9	Verde	0.75	150	Silicona
10	Verde	0.75	150	Silicona
11	Alb/Verde	2.5	690	Silicona

SIMBOLOGIA

 Faston hembra 6.35x0.8 Latón Estanado

 Funda para hembra silicona

 Terminal bloque Ø6.3 AMP 140545

 Terminal grapa weidmuller

2.5mm² : H2.5 1861.0

 Tubo silisol 180°C Ø12

 Abrazadera de silicona

Cableado portamañados mesa 1/2 Modelo		
N°	Pieza	
N°	Modificacion	
①	Acorotar 400 mm los cables 2,3,6,7,11	
Firma		
Fecha		
Dibujado	JON	95-5-18
Proyectado		
Comprobado		
Escala		
FAO		
Favor In		
COCII		
Firma		

Зип Общепит

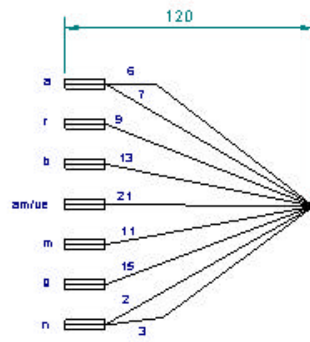
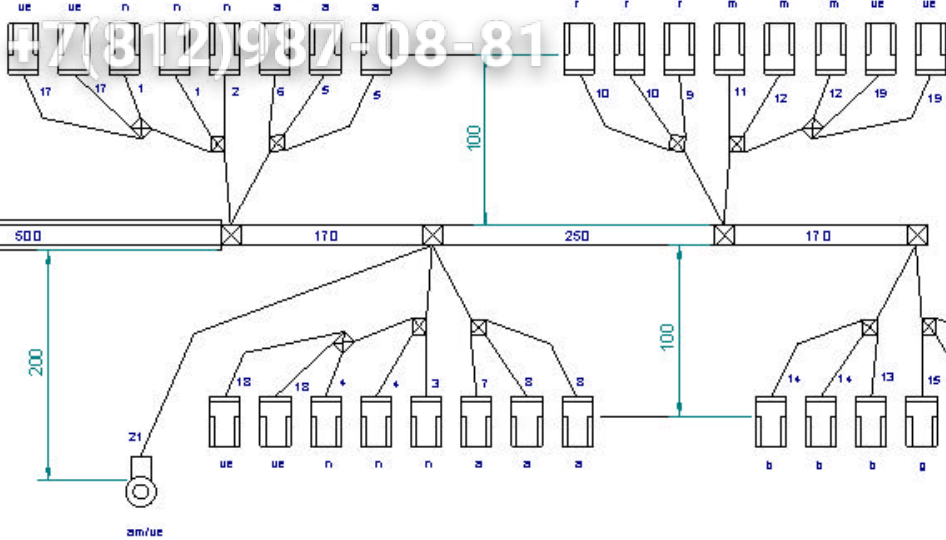

vsezip.ru



N°	Color	mm ²	Longitud	Material
1	Negro	0.75	150	Silicona
2	Negro	2.5	720	Silicona
3	Negro	2.5	890	Silicona
4	Negro	0.75	150	Silicona
5	Azul	0.75	60	Silicona
6	Azul	2.5	720	Silicona
7	Azul	2.5	890	Silicona
8	Azul	0.75	60	Silicona
9	Rojo	2.5	1140	Silicona
10	Rojo	0.75	60	Silicona
11	Marrón	2.5	1140	Silicona
12	Marrón	0.75	150	Silicona
13	Blanco	2.5	1310	Silicona
14	Blanco	0.75	60	Silicona
15	Gris	2.5	1210	Silicona
16	Gris	0.75	150	Silicona
17	Verde	0.75	150	Silicona
18	Verde	0.75	150	Silicona
19	Verde	0.75	150	Silicona
20	Verde	0.75	150	Silicona
21	Alio-verde	2.5	990	Silicona

SIMBOLOGIA

-  Faston hembra 6.35x0.8 Latón Estañado
-  Funda para hembra silicona
-  Terminal grapa weidmuller
-  Cableado
2.5mm² : H2.5 1861.0
5mm² : H6 1919.0
-  Tubo silisol 180°C Ø12
-  Abrazadera de silicona

CABLEADO BORNAS-COMUTADORES		
N°	Pieza	
N°	Modificacion	
Firma		Fecha
Dibujado		Legobitri 07-09-98
Proyectado		
Comprobado		
Escala		
		
		
<small>Elaborado en el taller de montaje de hardware y cableado</small>		



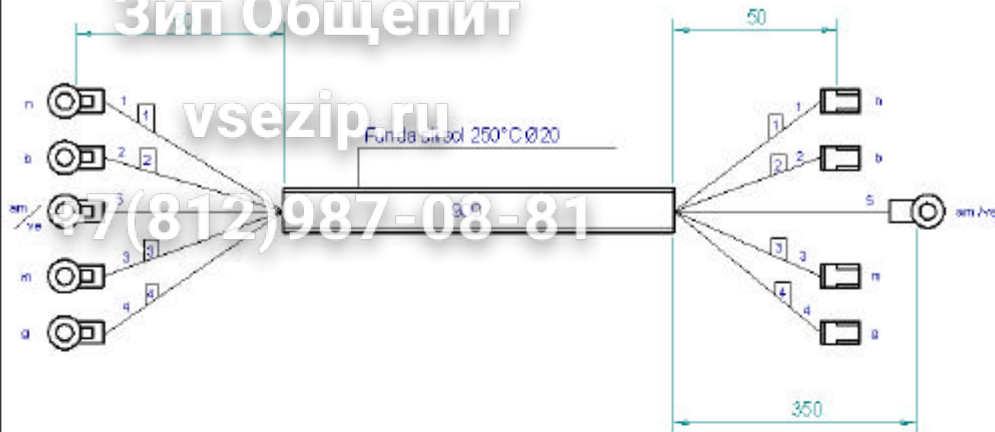

Зип Общежит

vsezip.ru

Fundamental 250°C Ø20







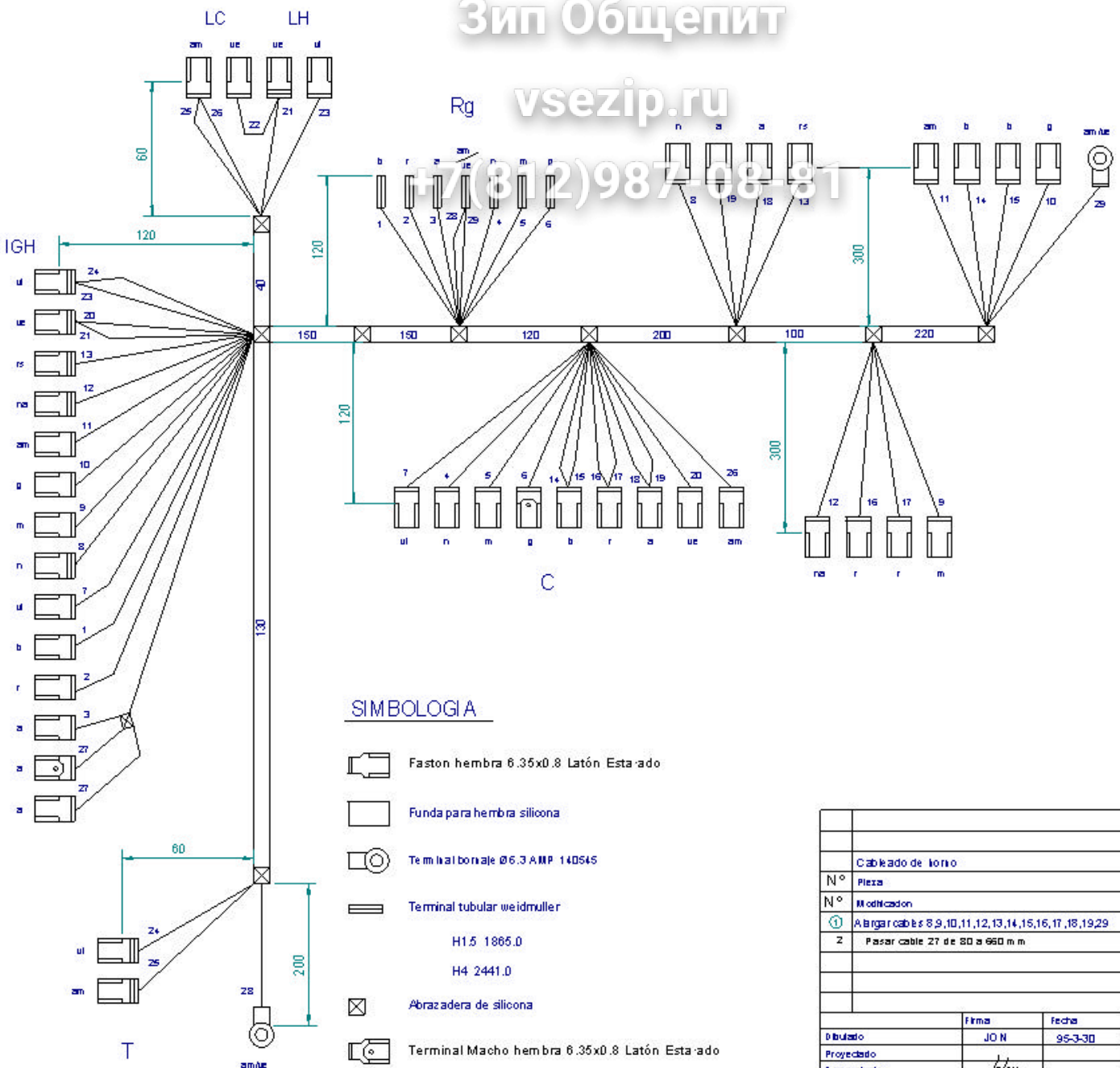

Nº	Color	mm ²	Longitud	Material
1	Negro	2,5	1000	Fibra-Vidrio
2	Blanco	2,5	1000	Fibra-Vidrio
3	Marrón	2,5	1000	Fibra-Vidrio
4	Gris	2,5	1000	Fibra-Vidrio
5	Alo/Verde	1,5	1300	Fibra-Vidrio

-  Faston hembra 6.35x0.8 Latón Esta ado
-  Funda para hembra silicona
-  Terminal redondo Ø6.1 Latón esta ado
-  Funda de silicona
-  Se alizadores

Cableado a placas				U-673014	
Nº	Pieza	Cent.	Material	Nº Clasificación	Acabado
Nº	Modificación	Propuesto de	Fecha	Tolerancias generales:	
①	Cambiar de silicona a fibra-vidrio	Mallo	95-5-24	< 5 ±	50-100 ±
				5-25 ±	> 100 ±
				25-50 ±	OK
		Prima	Fecha	Mecanizado superficial	
Dibujado		JON	95-5-22	FAGOR 	
Proyectado				Fagor Industrial, Koop. Elk, Mugatu	
Com probado					
Escala		COCINAS			Plano número
		Fibra de vidrio cableado vidrio con cable			HB-70041 -1
					Sustituye el N°
					Sustituido por



SIMBOLOGIA

-  Faston hembra 6.35x0.8 Latón Estañado
-  Funda para hembra silicona
-  Terminal bloque Ø6.3 AMP 140545
-  Terminal tubular weidmuller
H1.5 1865.0
H4 2441.0
-  Abrazadera de silicona
-  Terminal Macho hembra 6.35x0.8 Latón Estañado

Cableado de torio											
N°	Pieza										
N°	Modificacion										
1	Abriga cables 8,9,10,11,12,13,14,15,16,17,18,19,29										
2	Pasar cable 27 de 30 a 660 mm										
<table border="1"> <tr> <td>Firma</td> <td>Fecha</td> </tr> <tr> <td>Dibujado JO N</td> <td>95-3-30</td> </tr> <tr> <td>Proyectado</td> <td></td> </tr> <tr> <td>Comprobado</td> <td><i>[Signature]</i></td> </tr> <tr> <td>Escala</td> <td></td> </tr> </table>		Firma	Fecha	Dibujado JO N	95-3-30	Proyectado		Comprobado	<i>[Signature]</i>	Escala	
Firma	Fecha										
Dibujado JO N	95-3-30										
Proyectado											
Comprobado	<i>[Signature]</i>										
Escala											
FAO COD M											
Placa con 2 cables 11 y 12 y 13 cables por 1 cable de 24											