



ELECTRONIC OVENS

"Tocco Magico" Line (Magic Touch)

ELECTRIC COMBIMIX: ECVM6ES2, ECVM10ES2, ECVM20ES2, ECVM21ES2
ELECTRIC COMBIPLUS: ECV6ES2, ECV10ES2, ECV20ES2, ECV21ES2

TYPE: 6, 10, 20, 21

Spare parts



Зип Общепит

vsezip.ru

+7(812)987-08-81

vsezip.ru

+7(812)987-08-81

9. Spare parts

Motor compartment components: ECVME 6,10,2099

Control panel: ECVME 6.....101

Control panel: ECVME 10,20103

Motor compartment components: ECVME 21105

Control panel: ECVME 21107

Control panel: ECVME 21109

Motor compartment components: ECVPE 6,10,20111

Control panel: ECVPE 6113

Control panel: ECVPE 10,20115

Motor compartment components: ECVPE 21117

Control panel: ECVPE 21119

Control panel: ECVPE 21121

Motor compartment components: ECVPG 6,10,20117

Control panel: ECVPG 6.....117

Control panel: ECVPG 10,20.....117

Motor compartment components: ECVPG 21117



Control panel: ECVFG 21.....	117
Control panel: ECVPC 21.....	117
Door 6,10,20	123
Door 21	125
Front lower view 6,10,20.....	127
Front lower view 21.....	129
Door handle.....	131
Fan	133
Motor oil seal	135
Moisture control thermocouple.....	137
Steam generator.....	139
Burners	135
Automatic washer 1.....	141
Automatic washer 2.....	143

9.1 Voltage codes

Voltage	Voltage code
A	3/N/PE~400/230V 50Hz
B	~250V 16A 50Hz
C	3/N/PE~380/220V 50Hz
D	3/PE~200V 50-60Hz
F	2/PE 220-240V 50Hz
G	3/N/PE~415/240V 50Hz
H	3/PE~230V 50Hz
I	3/PE~220V 60Hz
J	3/PE~380 50Hz
K	3/PE~400V 50Hz
L	3/PE~415V 50Hz
M	3/PE~440V 60Hz
N	3/PE~460V 60Hz
O	3/PE~480V 60Hz
P	1/N/PE~220-240V 50Hz
R	2/PE~220-230V 60Hz
S	3/N/PE~400/230V 50Hz
T	3/PE~230V 60Hz
U	1/N/PE~100V 50-60Hz

9.2 Product codes

Product code	Full name
Model codes	
ECVME	ELECTRIC COMBIMIX: ECVM6ES2, ECVM10ES2, ECVM20ES2, ECVM21ES2
ECVPE	ELECTRIC COMBIPLUS: ECVP6ES2, ECVP10ES2, ECVP20ES2, ECVP21ES2
Type codes	
6	6
10	10
20	20
21	21

vsezip.ru

+7(812)987-08-81

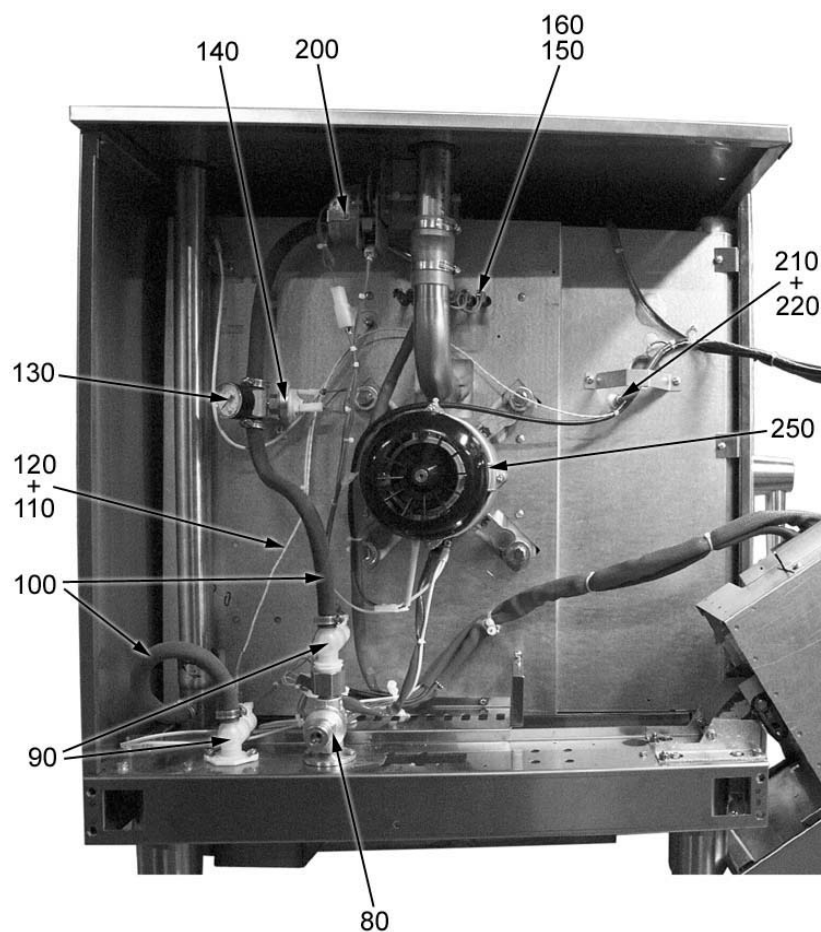

vsezip.ru

ID	Model	Type	Voltage	Description	P-code
Module: Motor compartment components: ECVME 6,10,20					
80	ECVME	6,10,20		Pressure reducer	3103634
90	ECVME	6,10,20		Solenoid valve, quenching	3103620
100	ECVME	6,10,20		Rubber hose for water connections	3103635
110	ECVME	6,10,20		Drain sensor	3103282
120	ECVME	6,10,20		Ogive	A016120
130	ECVME	6,10,20		Pressure gauge	A021910
140	ECVME	6,10,20		Water pressure switch	3103630
150	ECVME	6,10		Heating element 7500 W	A037460
160	ECVME	10		Heating element 7500 W	A037480
150	ECVME	20		Heating element 10500 W	A037470
160	ECVME	20		Heating element 9000 W	A037475
200	ECVME	6,10,20		Relief valve	3102335
210	ECVME	6,10,20		Chamber probe with wire L=800 mm	3103275
220	ECVME	6,10,20		Nut	A011607
250	ECVME	6,10,20	A	Chamber fan	3102312
250	ECVME	6,10,20	H	Chamber fan	3102212

ECVME=ELECTRIC COMBIMIX: ECVME6ES2, ECVME10ES2, ECVME20ES2, ECVME21ES2, ECVPE=ELECTRIC COMBIPLUS: ECVPE6ES2, ECVPE10ES2, ECVPE20ES2, ECVPE21ES2

6=6, 10=10, 20=20, 21=21

A=3/N/PE~400/230V 50Hz, H=3/PE~230V 50Hz, P=1/N/PE~220-240V 50Hz



vsezip.ru

+7(812)987-08-81

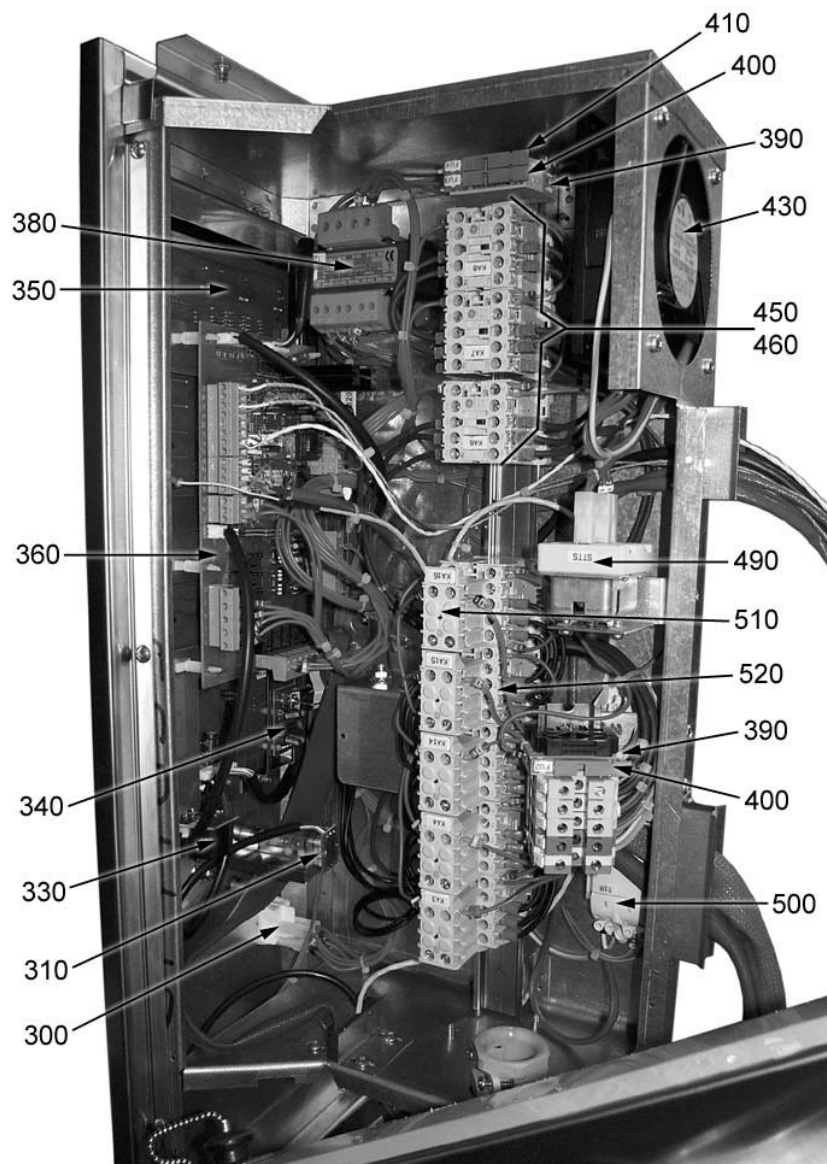

vsezip.ru

ID	Model	Type	Voltage	Description	P-code
Module: Control panel ECVME 6					
300	ECVME	6		Main switch	A038550
310	ECVME	6		Encoder	3103267
330	ECVME	6		Buzzer	3103266
340	ECVME	6		HACCP card	3103246
350	ECVME	6		Keypad card	3103251
360	ECVME	6		Base card	3103249
380	ECVME	6		Card power supply transformer	A047047
390	ECVME	6	A	Fuse-holder terminal	A034500
390	ECVME	6	H	Fuse-holder terminal	A034500
400	ECVME	6	A	Control fuse	A034540
400	ECVME	6	H	Control fuse	A034540
410	ECVME	6		Secondary fuse of card transformer	A034550
430	ECVME	6		Cooling fan	3102350
450	ECVME	6	A	Contacto	A047031
450	ECVME	6	H	Contacto	A047031
460	ECVME	6	H	Contacto	A047034
490	ECVME	6		Safety thermostat	A046190
500	ECVME	6		Chamber lights transformer	A047060
510	ECVME	6		Auxiliary contact	A047038
520	ECVME	6		Contacto for reduced heat	A047037

ECVME=ELECTRIC COMBIMIX: ECVME6ES2, ECVME10ES2, ECVME20ES2, ECVME21ES2, ECVPE=ELECTRIC COMBIPLUS: ECVPE6ES2, ECVPE10ES2, ECVPE20ES2, ECVPE21ES2

6=6, 10=10, 20=20, 21=21

A=3/N/PE~400/230V 50Hz, H=3/PE~230V 50Hz, P=1/N/PE~220-240V 50Hz



vsezip.ru

+7(812)987-08-81

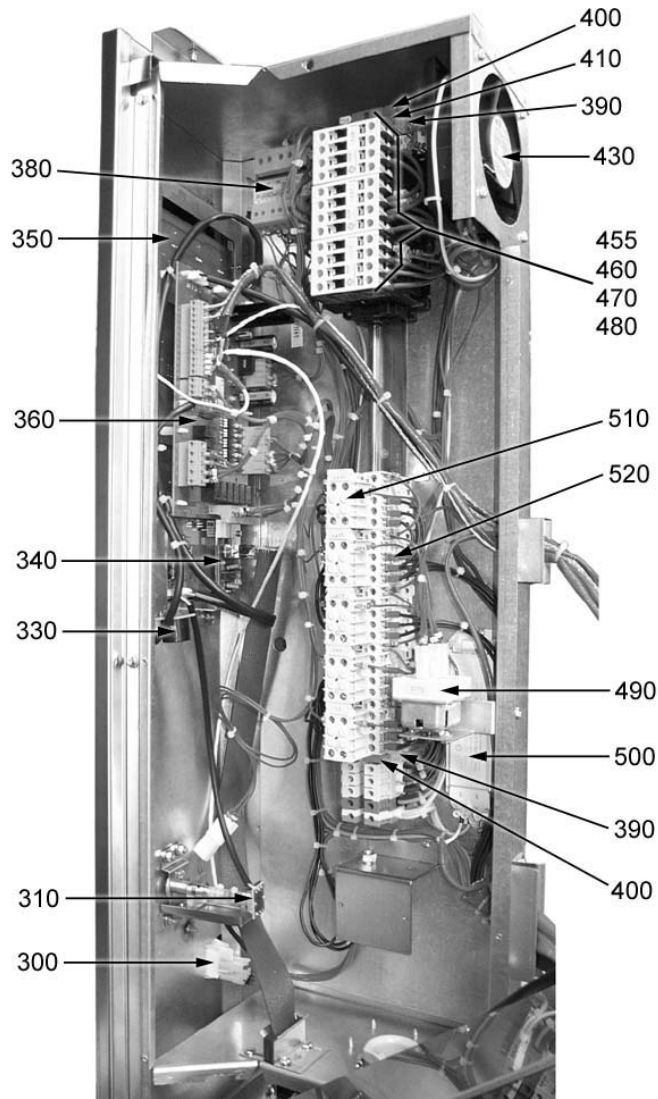

vsezip.ru

ID	Model	Type	Voltage	Description	P-code
Module: Control panel: ECVME 10,20					
300	ECVME	10,20		Switch	A038550
310	ECVME	10,20		Encoder	3103267
330	ECVME	10,20		Buzzer	3103266
340	ECVME	10,20		Serial card for HACCP	3103246
350	ECVME	10,20		Keypad card	3103251
360	ECVME	10,20		Base card	3103249
380	ECVME	10,20		Cards transformer	A047047
390	ECVME	10,20	A	Fuse-holder terminal	A034500
390	ECVME	10,20	H	Fuse-holder terminal	A034500
400	ECVME	10,20	A	5A fuse	A034540
400	ECVME	10,20	H	5A fuse	A034540
410	ECVME	10,20		3A fuse	A034550
430	ECVME	10,20		Cooling fan	3102350
460	ECVME	10	A	Contacto	A047034
460	ECVME	10	H	Contacto	A047034
455	ECVME	10	H	Contacto	A047033
480	ECVME	20	A	Contacto	A047036
480	ECVME	20	H	Contacto	A047036
470	ECVME	20	H	Contacto	A047035
490	ECVME	10,20		Safety thermostat	A046190
500	ECVME	10,20		Chamber lights transformer	A047060
510	ECVME	10,20		Auxiliary contact	A047038
520	ECVME	10,20		Minicontactor	A047037

ECVME=ELECTRIC COMBIMIX: ECVME6ES2, ECVME10ES2, ECVME20ES2, ECVME21ES2, ECVPE=ELECTRIC COMBIPLUS: ECVPE6ES2, ECVPE10ES2, ECVPE20ES2, ECVPE21ES2

6=6, 10=10, 20=20, 21=21

A=3/N/PE~400/230V 50Hz, H=3/PE~230V 50Hz, P=1/N/PE~220-240V 50Hz



vsezip.ru

+7(812)987-08-81

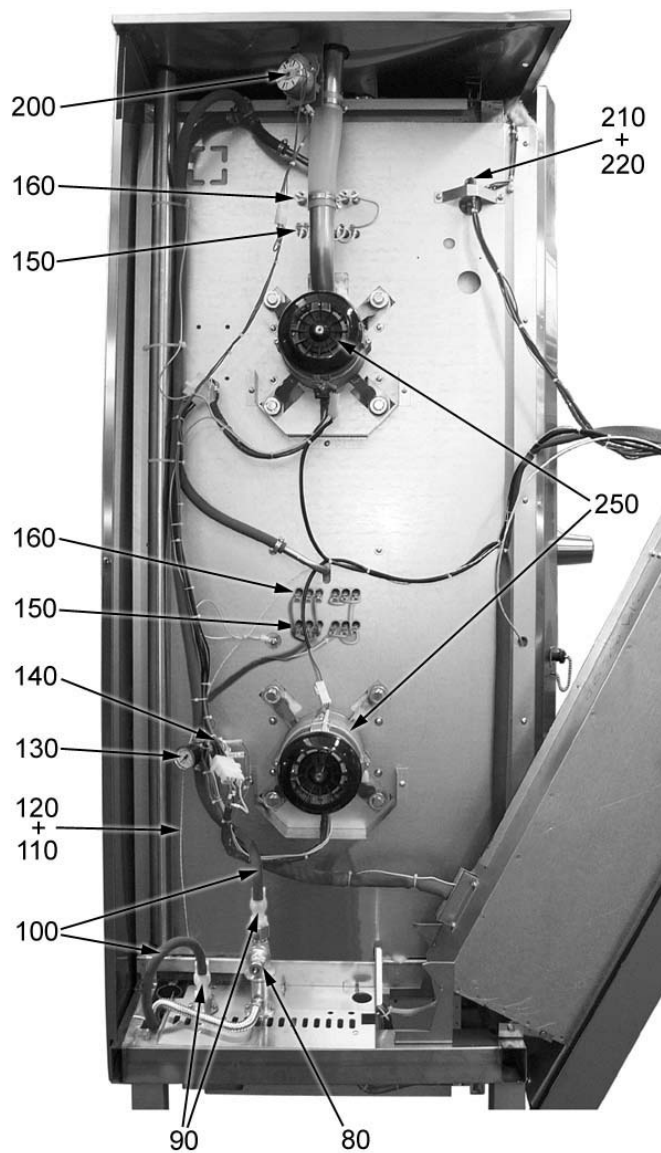

vsezip.ru

ID	Model	Type	Voltage	Description	P-code
Module: Motor compartment components: ECVME 21					
80	ECVME	21		Pressure reducer	3103634
90	ECVME	21		Solenoid valve, quenching	3103620
100	ECVME	21		Rubber hose for water connections	3103635
110	ECVME	21		Drain sensor	3103282
120	ECVME	21		Ogive	A016120
130	ECVME	21		Pressure gauge	A021910
140	ECVME	21		Water pressure switch	3103630
150	ECVME	21		Heating element 7500 W	A037460
160	ECVME	21		Heating element 7500 W	A037480
200	ECVME	21		Relief valve	3102335
210	ECVME	21		Chamber probe with wire L=800 mm	3103275
220	ECVME	21		Nut	A011607
250	ECVME	21	A	Chamber fan	3102312
250	ECVME	21	H	Chamber fan	3102212

ECVME=ELECTRIC COMBIMIX: ECVME6ES2, ECVME10ES2, ECVME20ES2, ECVME21ES2, ECVPE=ELECTRIC COMBIPLUS: ECVPE6ES2, ECVPE10ES2, ECVPE20ES2, ECVPE21ES2

6=6, 10=10, 20=20, 21=21

A=3/N/PE~400/230V 50Hz, H=3/PE~230V 50Hz, P=1/N/PE~220-240V 50Hz

vsezip.ru

+7(812)987-08-81

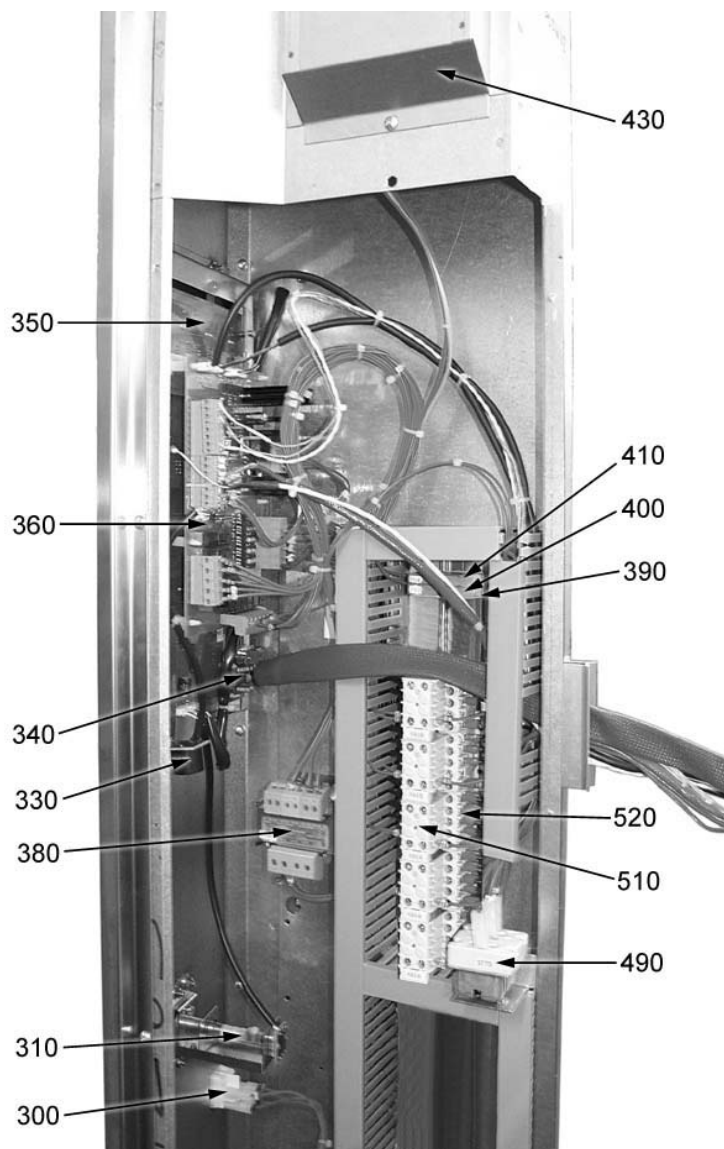

vsezip.ru

ID	Model	Type	Voltage	Description	P-code
Module: Control panel: ECVME 21					
300	ECVME	21		Main switch	A038550
310	ECVME	21		Encoder	3103267
330	ECVME	21		Buzzer	3103266
340	ECVME	21		HACCP card	3103246
350	ECVME	21		Keypad card	3103251
360	ECVME	21		Base card	3103249
380	ECVME	21		Card power supply transformer	A047047
390	ECVME	21	A	Fuse-holder terminal	A034500
390	ECVME	21	H	Fuse-holder terminal	A034500
400	ECVME	21	A	Control fuse	A034540
400	ECVME	21	H	Control fuse	A034540
410	ECVME	21		Secondary fuse of card transformer	A034550
430	ECVME	21		Cooling fan	3102350
490	ECVME	21		Safety thermostat	A046190
510	ECVME	21		Auxiliary contact	A047038
520	ECVME	21		Contact for reduced heat	A047037

ECVME=ELECTRIC COMBIMIX: ECVME6ES2, ECVME10ES2, ECVME20ES2, ECVME21ES2, ECVPE=ELECTRIC COMBIPLUS: ECVPE6ES2, ECVPE10ES2, ECVPE20ES2, ECVPE21ES2

6=6, 10=10, 20=20, 21=21

A=3/N/PE~400/230V 50Hz, H=3/PE~230V 50Hz, P=1/N/PE~220-240V 50Hz

vsezip.ru

+7(812)987-08-81

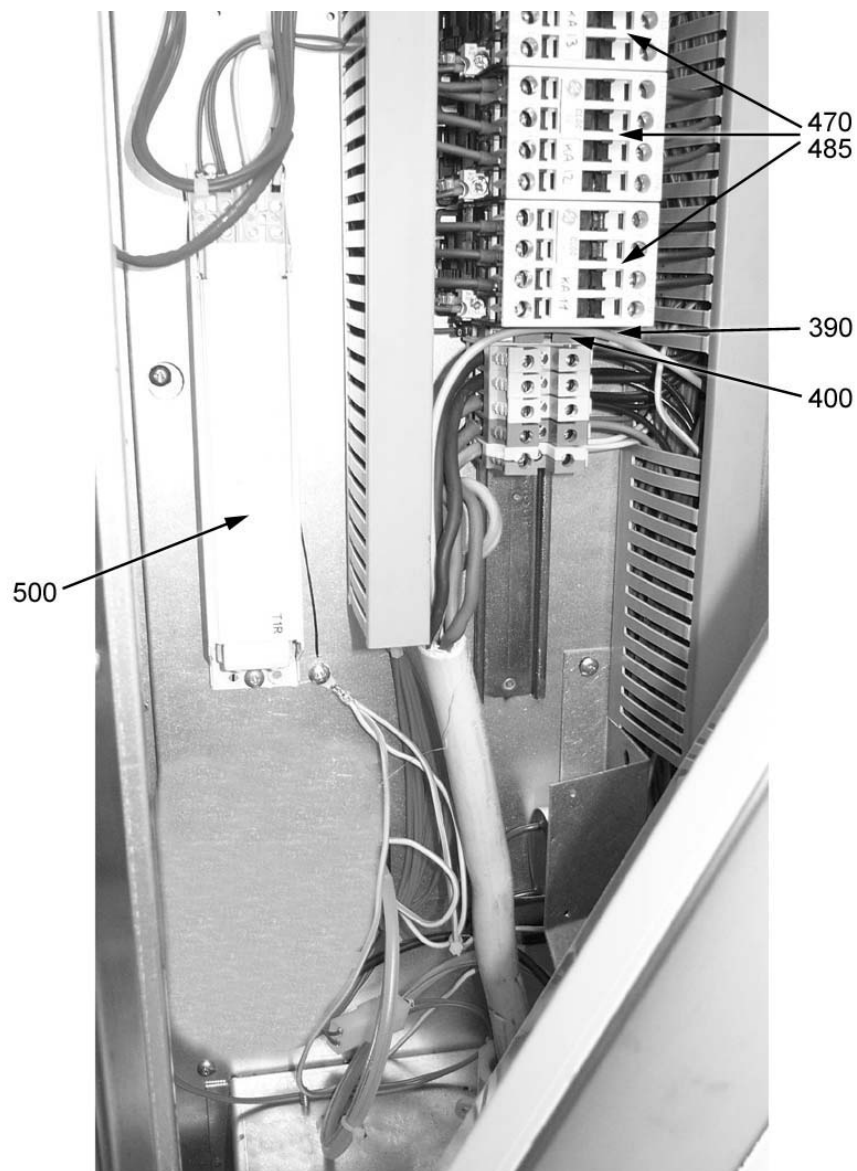

vsezip.ru

ID	Model	Type	Voltage	Description	P-code
Module: Control panel: ECVME 21					
390	ECVME	21	A	Fuse-holder terminal	A034500
390	ECVME	21	H	Fuse-holder terminal	A034500
400	ECVME	21	A	5A fuse	A034540
400	ECVME	21	H	5A fuse	A034540
470	ECVME	21	A	Contacto	A047035
470	ECVME	21	H	Contacto	A047035
485	ECVME	21	H	Contacto	A047041
500	ECVME	21		Chamber lights transformer	A047061

ECVME=ELECTRIC COMBIMIX: ECVME6ES2, ECVME10ES2, ECVME20ES2, ECVME21ES2, ECVPE=ELECTRIC COMBIPUS: ECVPE6ES2, ECVPE10ES2, ECVPE20ES2, ECVPE21ES2

6=6, 10=10, 20=20, 21=21

A=3/N/PE~400/230V 50Hz, H=3/PE~230V 50Hz, P=1/N/PE~220-240V 50Hz



vsezip.ru

+7(812)987-08-81

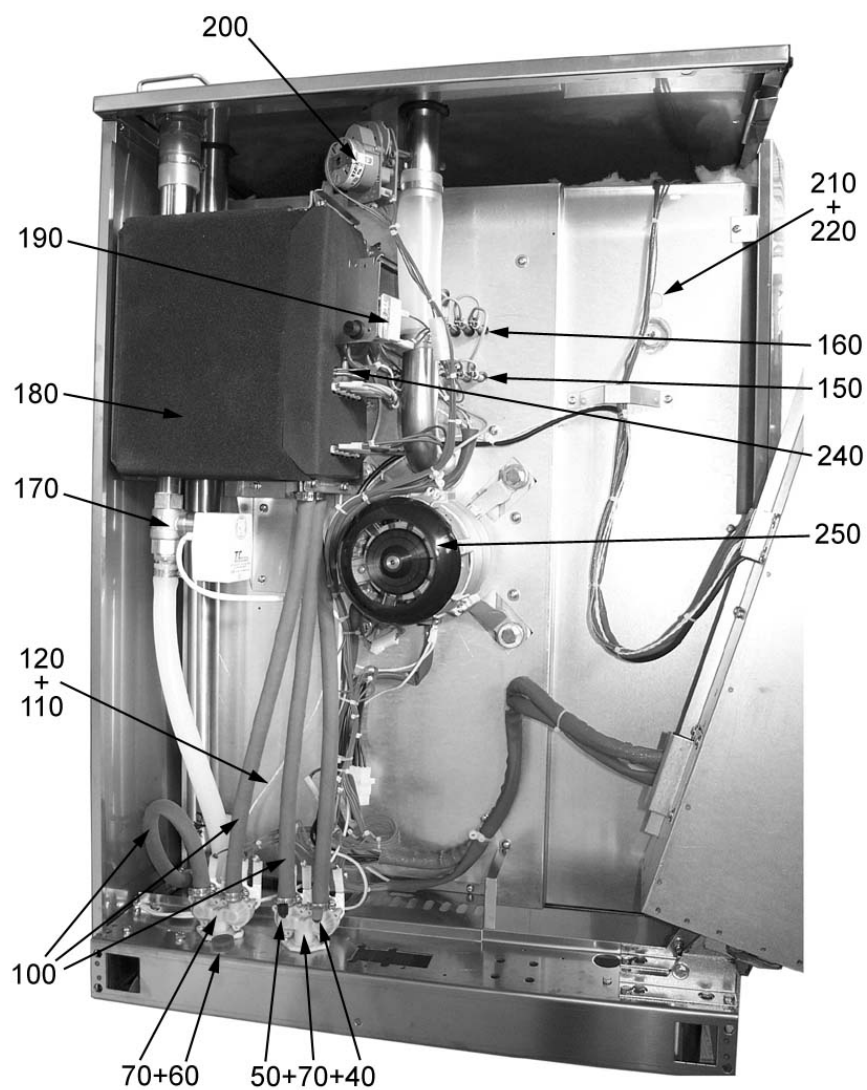

vsezip.ru

ID	Model	Type	Voltage	Description	P-code
Module: Motor compartment components: ECVPE 6,10,20					
40	ECVPE	6,10,20		Capacity reduction (green)	3103637
50	ECVPE	6,10,20		Capacity reduction (black)	3103642
60	ECVPE	6,10,20		Flow-regulator (red)	3103643
70	ECVPE	6,10,20		Solenoid valve, flushing	3103610
100	ECVPE	6,10,20		Rubber hose for water connections	3103635
110	ECVPE	6,10,20		Drain sensor	3103282
120	ECVPE	6,10,20		Ogive	A016120
150	ECVPE	6,10		Heating element 7500 W	A037460
150	ECVPE	20		Heating element 10500 W	A037470
160	ECVPE	10		Heating element 7500 W	A037480
160	ECVPE	20		Heating element 9000 W	A037475
170	ECVPE	6,10,20		Motor valve, drain	3103590
180	ECVPE	6		Steam generator 7.5 kW	3103300
180	ECVPE	10,20		Steam generator 15 kW	3103400
190	ECVPE	6,10,20		Safety thermostat, boiler	A046185
200	ECVPE	6,10,20		Relief valve	3102335
210	ECVPE	6,10,20		Chamber probe with wire L=800 mm	3103275
220	ECVPE	6,10,20		Nut	A011607
240	ECVPE	6,10,20		Boiler sensor	3103281
250	ECVPE	6,10,20	A	Chamber fan	3102312
250	ECVPE	6,10,20	H	Chamber fan	3102212

ECVME=ELECTRIC COMBIMIX: ECVME6ES2, ECVME10ES2, ECVME20ES2, ECVME21ES2, ECVPE=ELECTRIC COMBIPLUS: ECVPE6ES2, ECVPE10ES2, ECVPE20ES2, ECVPE21ES2

6=6, 10=10, 20=20, 21=21

A=3/N/PE~400/230V 50Hz, H=3/PE~230V 50Hz, P=1/N/PE~220-240V 50Hz



vsezip.ru

+7(812)987-08-81

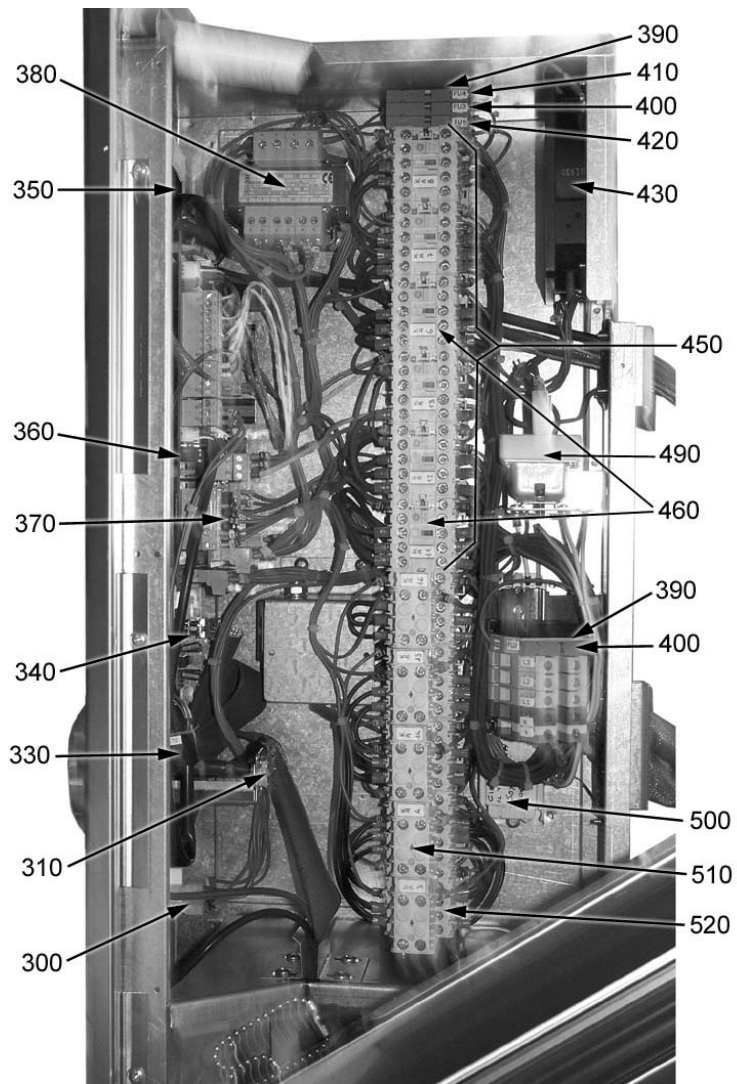

vsezip.ru

ID	Model	Type	Voltage	Description	P-code
Module: Control panel: ECVPE 6					
300	ECVPE	6		Main switch	A038550
310	ECVPE	6		Encoder	3103267
330	ECVPE	6		Buzzer	3103266
340	ECVPE	6		HACCP card	3103246
350	ECVPE	6		Keypad card	3103251
360	ECVPE	6		Base card	3103249
370	ECVPE	6		Boiler expansion	3103252
380	ECVPE	6		Card power supply transformer	A047047
390	ECVPE	6	A	Fuse-holder terminal	A034500
390	ECVPE	6	H	Fuse-holder terminal	A034500
400	ECVPE	6	A	Control fuse	A034540
400	ECVPE	6	H	Control fuse	A034540
410	ECVPE	6		Secondary fuse of card transformer	A034550
420	ECVPE	6		Secondary fuse of card transformer	A034510
430	ECVPE	6		Cooling fan	3102350
450	ECVPE	6	A	Contacto	A047031
450	ECVPE	6	H	Contacto	A047031
460	ECVPE	6	H	Contacto	A047034
490	ECVPE	6		Safety thermostat	A046190
500	ECVPE	6		Chamber lights transformer	A047060
510	ECVPE	6		Auxiliary contact	A047038
520	ECVPE	6		Contacto for reduced heat	A047037

ECVME=ELECTRIC COMBIMIX: ECVME6ES2, ECVME10ES2, ECVME20ES2, ECVME21ES2, ECVPE=ELECTRIC COMBIPLUS: ECVPE6ES2, ECVPE10ES2, ECVPE20ES2, ECVPE21ES2

6=6, 10=10, 20=20, 21=21

A=3/N/PE~400/230V 50Hz, H=3/PE~230V 50Hz, P=1/N/PE~220-240V 50Hz

vsezip.ru

+7(812)987-08-81

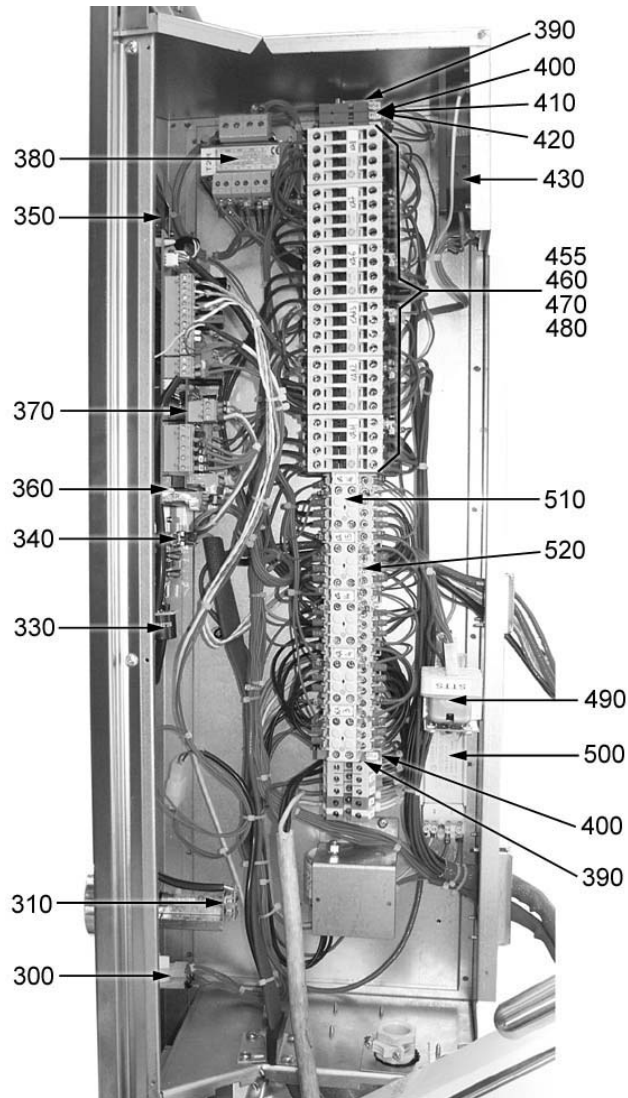

ID	Model	Type	Voltage	Description	P-code
Module: Control panel: ECVPE 10,20					
300	ECVPE	10,20		Switch	A038550
310	ECVPE	10,20		Encoder	3103267
330	ECVPE	10,20		Buzzer	3103266
340	ECVPE	10,20		Serial card for HACCP	3103246
350	ECVPE	10,20		Keypad card	3103251
360	ECVPE	10,20		Base card	3103249
370	ECVPE	10,20		Boiler expansion card	3103252
380	ECVPE	10,20		Cards transformer	A047047
390	ECVPE	10,20	A	Fuse-holder terminal	A034500
390	ECVPE	10,20	H	Fuse-holder terminal	A034500
400	ECVPE	10,20	A	5A fuse	A034540
400	ECVPE	10,20	H	5A fuse	A034540
410	ECVPE	10,20		3A fuse	A034550
420	ECVPE	10,20		1A fuse	A034510
430	ECVPE	10,20		Cooling fan	3102350
460	ECVPE	10	A	Contactor	A047034
460	ECVPE	20	A	Contactor	A047034
480	ECVPE	20	A	Contactor	A047036
460	ECVPE	10	H	Contactor	A047034
455	ECVPE	10	H	Contactor	A047033
460	ECVPE	20	H	Contactor	A047034
470	ECVPE	20	H	Contactor	A047035
480	ECVPE	20	H	Contactor	A047036
455	ECVPE	20	H	Contactor	A047033
490	ECVPE	10,20		Safety thermostat	A046190
500	ECVPE	10,20		Chamber lights transformer	A047060
510	ECVPE	10,20		Auxiliary contact	A047038
520	ECVPE	10,20		Minicontactor	A047037

ECVME=ELECTRIC COMBIMIX: ECVME6ES2, ECVME10ES2, ECVME20ES2, ECVME21ES2, ECVPE=ELECTRIC COMBIPLUS: ECVPE6ES2, ECVPE10ES2, ECVPE20ES2, ECVPE21ES2

6=6, 10=10, 20=20, 21=21

A=3/N/PE~400/230V 50Hz, H=3/PE~230V 50Hz, P=1/N/PE~220-240V 50Hz

vsezip.ru

+7(812)987-08-81

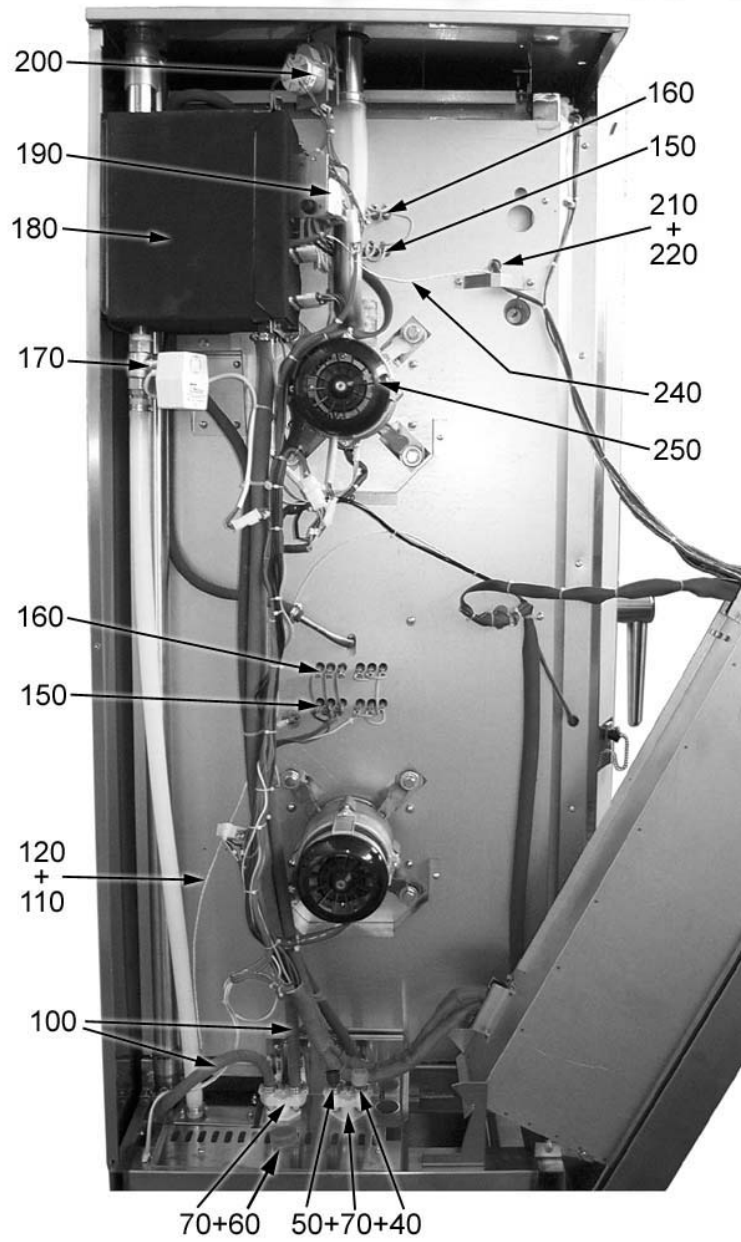

vsezip.ru

ID	Model	Type	Voltage	Description	P-code
Module: Motor compartment components: ECVPE 21					
40	ECVPE	21		Capacity reduction (green)	3103637
50	ECVPE	21		Capacity reduction (black)	3103642
60	ECVPE	21		Flow-regulator (red)	3103643
70	ECVPE	21		2-way electro-valve	3103610
100	ECVPE	21		Rubber hose for water connections	3103635
110	ECVPE	21		Oven drain thermocouple	3103282
120	ECVPE	21		Ogive	A016120
150	ECVPE	21		Heating element 7.5 kW	A037460
160	ECVPE	21		Heating element	A037480
170	ECVPE	21		Motor valve	3103590
180	ECVPE	21		Steam generator 15 kW	3103400
190	ECVPE	21		Boiler safety thermostat	A046185
200	ECVPE	21		Dehumidifier valve motor	3102335
210	ECVPE	21		Chamber probe with wire L=800 mm	3103275
220	ECVPE	21		Nut	A011607
240	ECVPE	21		Steam generator thermocouple	3103281
250	ECVPE	21	A	Three-phase motor	3102312
250	ECVPE	21	H	Single/three-phase motor	3102212

ECVME=ELECTRIC COMBIMIX: ECVME6ES2, ECVME10ES2, ECVME20ES2, ECVME21ES2, ECVPE=ELECTRIC COMBIPLUS: ECVPE6ES2, ECVPE10ES2, ECVPE20ES2, ECVPE21ES2

6=6, 10=10, 20=20, 21=21

A=3/N/PE~400/230V 50Hz, H=3/PE~230V 50Hz, P=1/N/PE~220-240V 50Hz

vsezip.ru

+7(812)987-08-81

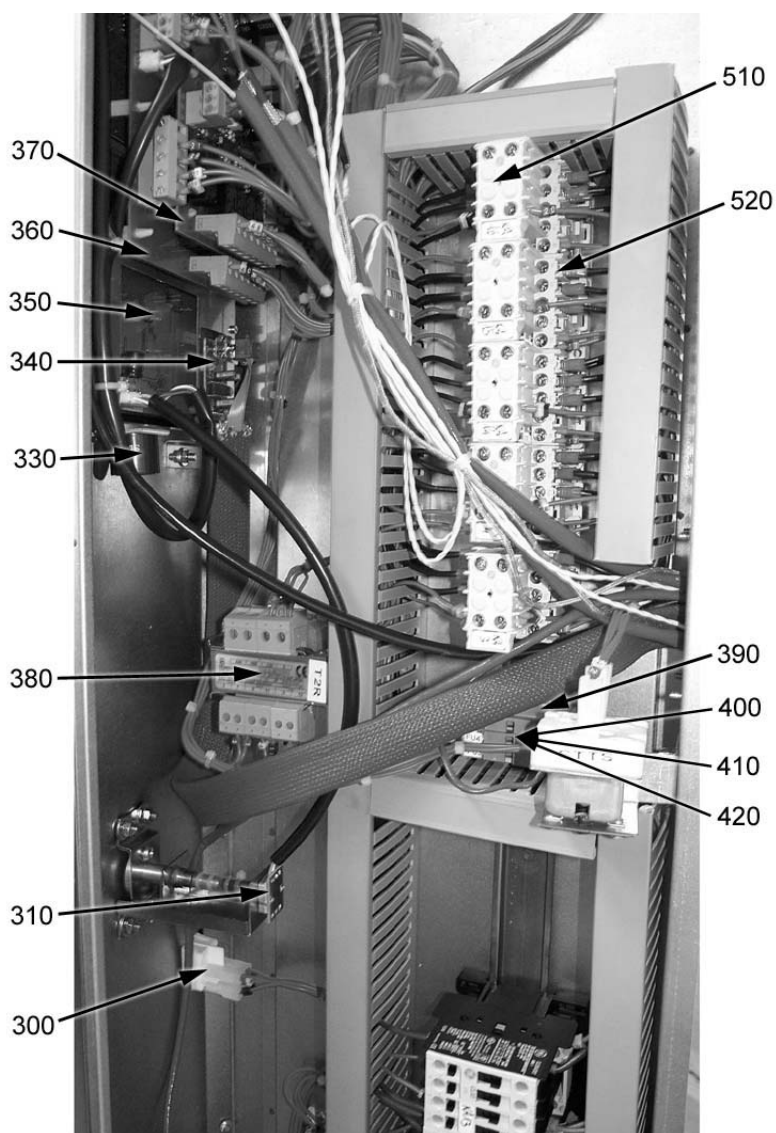

vsezip.ru

ID	Model	Type	Voltage	Description	P-code
Module: Control panel: ECVPE 21					
300	ECVPE	21		Main switch	A038550
310	ECVPE	21		Encoder	3103267
330	ECVPE	21		Buzzer	3103266
340	ECVPE	21		HACCP card	3103246
350	ECVPE	21		Keypad card	3103251
360	ECVPE	21		Base card	3103249
370	ECVPE	21		Boiler expansion	3103252
380	ECVPE	21		Card power supply transformer	A047047
390	ECVPE	21	A	Fuse-holder terminal	A034500
390	ECVPE	21	H	Fuse-holder terminal	A034500
400	ECVPE	21	A	Control fuse	A034540
400	ECVPE	21	H	Control fuse	A034540
410	ECVPE	21		Secondary fuse of card transformer	A034550
420	ECVPE	21		Secondary fuse of card transformer	A034510
510	ECVPE	21		Auxiliary contact	A047038
520	ECVPE	21		Contact for reduced heat	A047037

ECVME=ELECTRIC COMBIMIX: ECVME6ES2, ECVME10ES2, ECVME20ES2, ECVME21ES2, ECVPE=ELECTRIC COMBIPLUS: ECVPE6ES2, ECVPE10ES2, ECVPE20ES2, ECVPE21ES2

6=6, 10=10, 20=20, 21=21

A=3/N/PE~400/230V 50Hz, H=3/PE~230V 50Hz, P=1/N/PE~220-240V 50Hz

vsezip.ru

+7(812)987-08-81

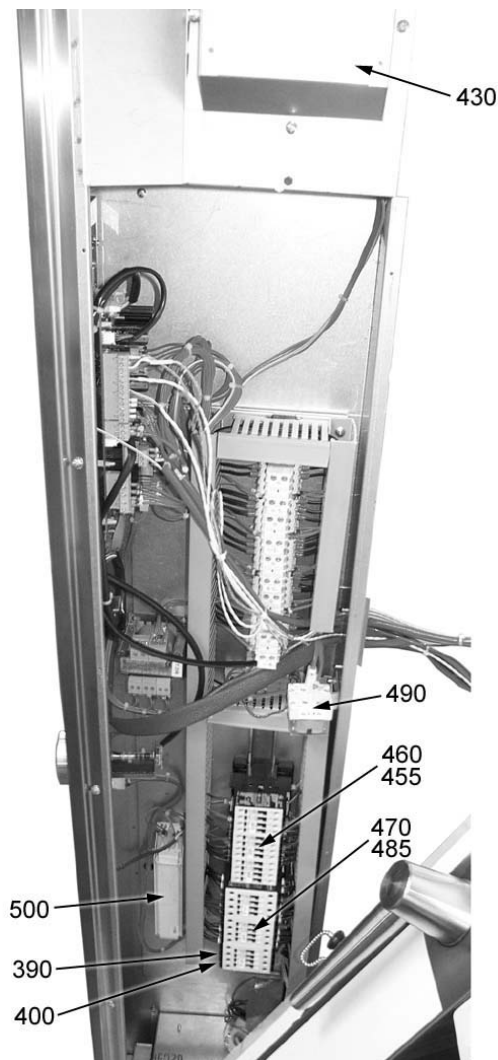

vsezip.ru

ID	Model	Type	Voltage	Description	P-code
Module: Control panel: ECVPE 21					
390	ECVPE	21	A	Fuse-holder terminal	A034500
390	ECVPE	21	H	Fuse-holder terminal	A034500
400	ECVPE	21	A	5A fuse	A034540
400	ECVPE	21	H	5A fuse	A034540
430	ECVPE	21		Cooling fan	3102350
460	ECVPE	21	A	Contactactor	A047034
460	ECVPE	21	H	Contactactor	A047034
455	ECVPE	21	H	Contactactor	A047033
470	ECVPE	21	A	Contactactor	A047035
470	ECVPE	21	H	Contactactor	A047035
485	ECVPE	21	H	Contactactor	A047041
490	ECVPE	21		Safety thermostat	A046190
500	ECVPE	21		Chamber lights transformer	A047061

ECVME=ELECTRIC COMBIMIX: ECVME6ES2, ECVME10ES2, ECVME20ES2, ECVME21ES2, ECVPE=ELECTRIC COMBIPLUS: ECVPE6ES2, ECVPE10ES2, ECVPE20ES2, ECVPE21ES2

6=6, 10=10, 20=20, 21=21

A=3/N/PE~400/230V 50Hz, H=3/PE~230V 50Hz, P=1/N/PE~220-240V 50Hz

vsezip.ru

+7(812)987-08-81

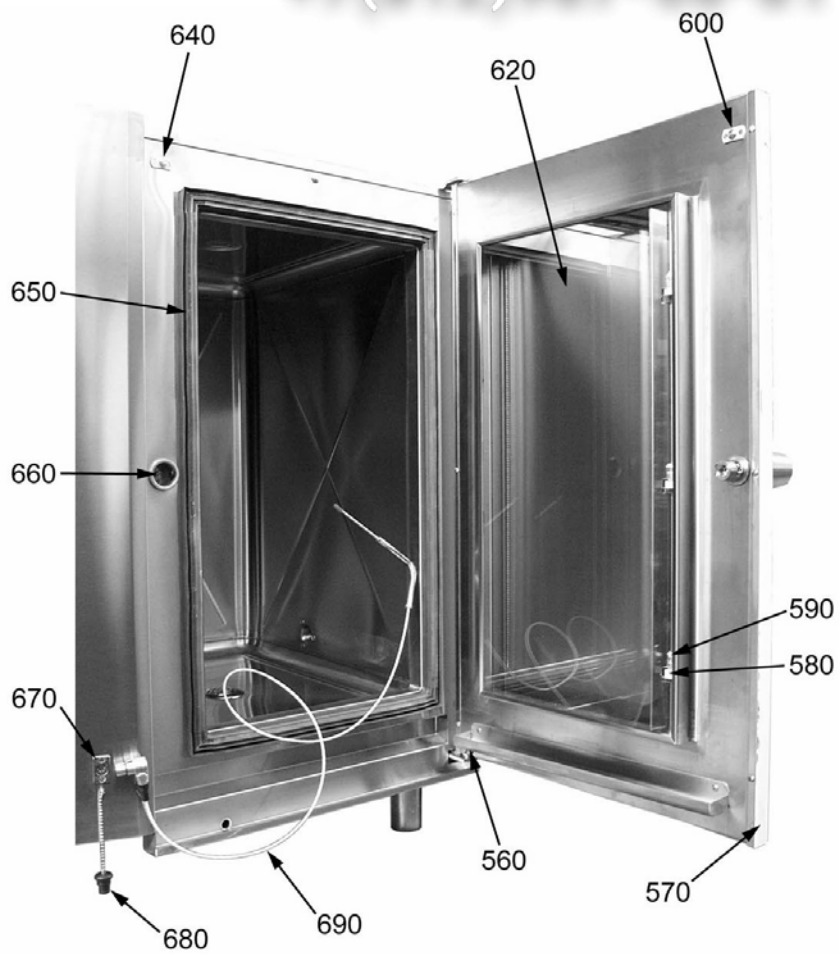

vsezip.ru

ID	Model	Type	Voltage	Description	P-code
Module: Door 6,10,20					
560		6,10,20		Door tray cap	3106355
570		6,10,20		End of stroke magnet	3108890
580		6		Lamp holder	3108860
580		10,20		Lamp holder	3108860
590		6		Halogen lamp	3108850
590		10,20		Halogen lamp	3108850
600		6,10,20		Door switch	3108879
620		6		Inner door glass	3108300
620		10		Inner door glass	3108400
620		20		Inner door glass	3108500
640		6,10,20		Front-panel contact	3108870
650		6		Door gasket	3108600
650		10		Door gasket	3108700
650		20		Door gasket	3108800
660		6,10,20		Door closing striking plate	3107910
670		6,10,20		Three-pole panel connector	3103285
680		6,10,20		Cap for panel connector	3103290
690		6,10,20		Insert probe	3103280

ECVME=ELECTRIC COMBIMIX: ECVM6ES2, ECVM10ES2, ECVM20ES2, ECVM21ES2, ECVPE=ELECTRIC COMBIPLUS: ECVP6ES2, ECVP10ES2, ECVP20ES2, ECVP21ES2

6=6, 10=10, 20=20, 21=21

A=3/N/PE~400/230V 50Hz, H=3/PE~230V 50Hz, P=1/N/PE~220-240V 50Hz



vsezip.ru

+7(812)987-08-81

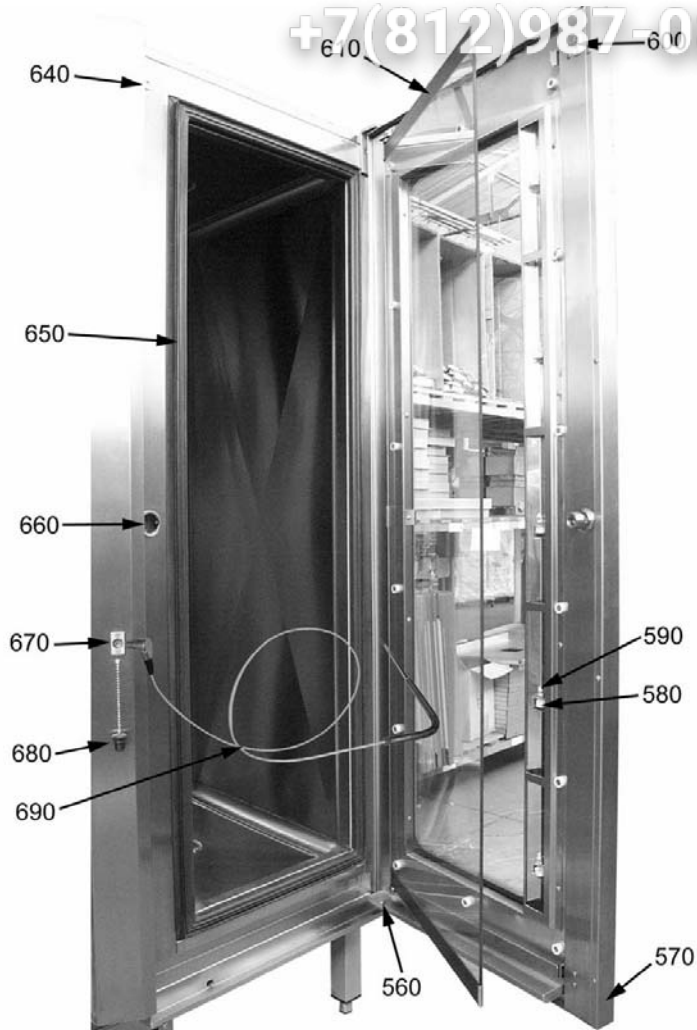

vsezip.ru

ID	Model	Type	Voltage	Description	P-code
Module: Door 21					
560		21		Door tray cap	3106355
570		21		End of stroke magnet	3108890
580		21		Lamp holder	3108860
590		21		Halogen lamp	3108850
600		21		Door switch	3108879
610		21		Inner door glass kit	3199009
640		21		Front-panel contact	3108870
650		21		Door gasket	3108820
660		21		Door closing striking plate	3107910
670		21		Three-pole panel connector	3103285
680		21		Cap for panel connector	3103290
690		21		Insert probe	3103280

ECVME=ELECTRIC COMBIMIX: ECVM6ES2, ECVM10ES2, ECVM20ES2, ECVM21ES2, ECVPE=ELECTRIC COMBIPLUS: ECVP6ES2, ECVP10ES2, ECVP20ES2, ECVP21ES2

6=6, 10=10, 20=20, 21=21

A=3/N/PE~400/230V 50Hz, H=3/PE~230V 50Hz, P=1/N/PE~220-240V 50Hz

vsezip.ru

+7(812)987-08-81

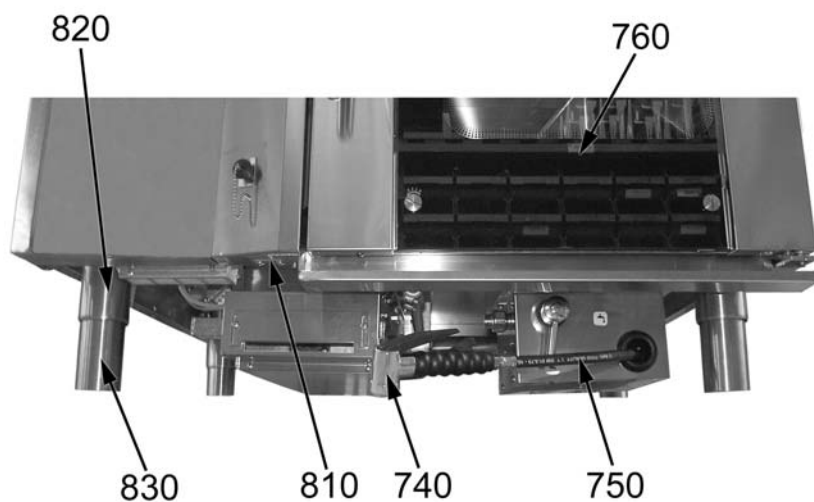

vsezip.ru

ID	Model	Type	Voltage	Description	P-code
Module: Front lower view (6,10,20)					
740		6,10,20		Shower	A022466
750		6,10,20		Hose with unions	A022467
760		6		KIT, dark blue outer door glass 6	3199001
760		6		KIT, red outer door glass 6	3199006
760		10		KIT, dark blue outer door glass 10	3199002
760		10		KIT, red outer door glass 10	3199007
760		20		KIT, dark blue outer door glass 20	3199003
760		20		KIT, red outer door glass 20	3199008
810		6,10,20		Door switch with wire L=2000 mm	A047085
820		6,10,20		Foot-holder sleeve	A028620
830		6,10,20		Foot	A028610

ECVME=ELECTRIC COMBIMIX: ECVM6ES2, ECVM10ES2, ECVM20ES2, ECVM21ES2, ECVPE=ELECTRIC COMBIPLUS: ECVP6ES2, ECVP10ES2, ECVP20ES2, ECVP21ES2

6=6, 10=10, 20=20, 21=21

A=3/N/PE~400/230V 50Hz, H=3/PE~230V 50Hz, P=1/N/PE~220-240V 50Hz

vsezip.ru

+7(812)987-08-81

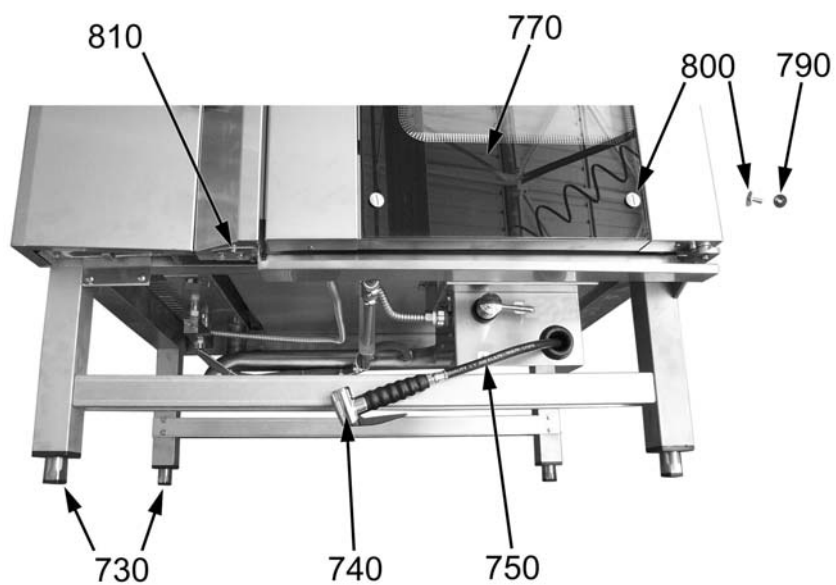

vsezip.ru

ID	Model	Type	Voltage	Description	P-code
Module: Front lower view 21					
730		21		Foot	A028630
740		21		Shower	A022466
750		21		Hose with unions	A022467
770		21		Outer door glass	3108210
770		21		Red outer door glass	3108220
790		21		Gasket for oven tray plug	3106353
800		21		Screw	3106062
810		21		Door switch with wire L=2000 mm	A047085

ECVME=ELECTRIC COMBIMIX: ECVM6ES2, ECVM10ES2, ECVM20ES2, ECVM21ES2, ECVPE=ELECTRIC COM-
BIPLUS: ECVP6ES2, ECVP10ES2, ECVP20ES2, ECVP21ES2

6=6, 10=10, 20=20, 21=21

A=3/N/PE~400/230V 50Hz, H=3/PE~230V 50Hz, P=1/N/PE~220-240V 50Hz

vsezip.ru

+7(812)987-08-81

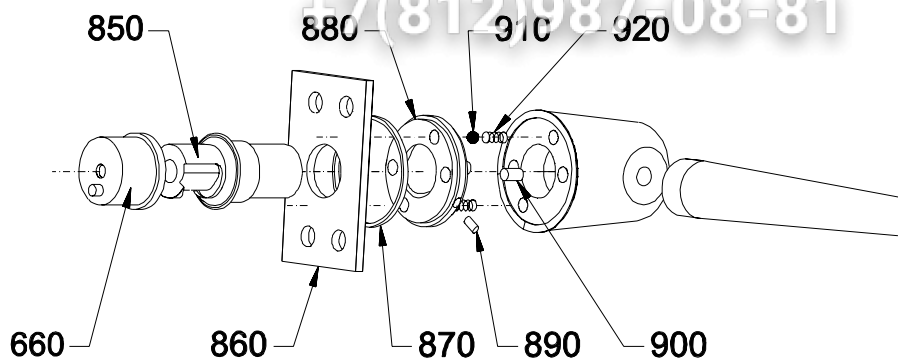

vsezip.ru

ID	Model	Type	Voltage	Description	P-code
Module: Door handle					
660				Door closing striking plate	3107910
850		6,10,20		Door handle stop	3107915
850		21		Door handle stop	3107991
860				Bracket	3107945
870				Ring	3107941
880				rod base	3107935
890				Screw	3107950
900				Piolino	3107930
910				Spheres	A011409
920				Spring	3107955

ECVME=ELECTRIC COMBIMIX: ECVM6ES2, ECVM10ES2, ECVM20ES2, ECVM21ES2, ECVPE=ELECTRIC COMBIPLUS: ECVP6ES2, ECVP10ES2, ECVP20ES2, ECVP21ES2

6=6, 10=10, 20=20, 21=21

A=3/N/PE~400/230V 50Hz, H=3/PE~230V 50Hz, P=1/N/PE~220-240V 50Hz



vsezip.ru

+7(812)987-08-81

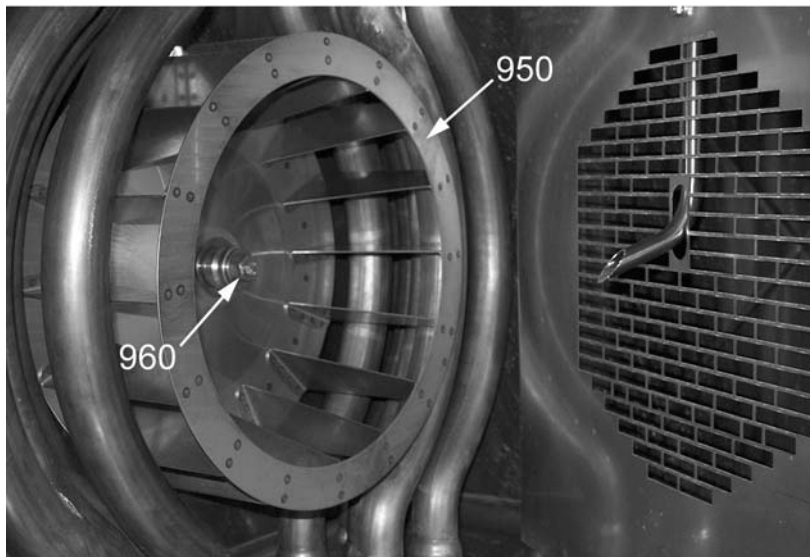

vsezip.ru

ID	Model	Type	Voltage	Description	P-code
Module: Fan					
950		6,10		16-blade fan 50 Hz	3101600
950		20		12-blade fan 50 Hz	3101630
950		21		16-blade fan 50 Hz	3101600
950		6,10		12-blade fan 60 Hz	3101650
950		20		12-blade fan 60 Hz	3101680
950		21		12-blade fan 60 Hz	3101650
960		6,10,20		LH fan locking screw	3102250
960		21		LH fan locking screw	3102250

ECVME=ELECTRIC COMBIMIX: ECVM6ES2, ECVM10ES2, ECVM20ES2, ECVM21ES2, ECVPE=ELECTRIC COM-
BIPLUS: ECVP6ES2, ECVP10ES2, ECVP20ES2, ECVP21ES2

6=6, 10=10, 20=20, 21=21

A=3/N/PE~400/230V 50Hz, H=3/PE~230V 50Hz, P=1/N/PE~220-240V 50Hz



vsezip.ru

+7(812)987-08-81

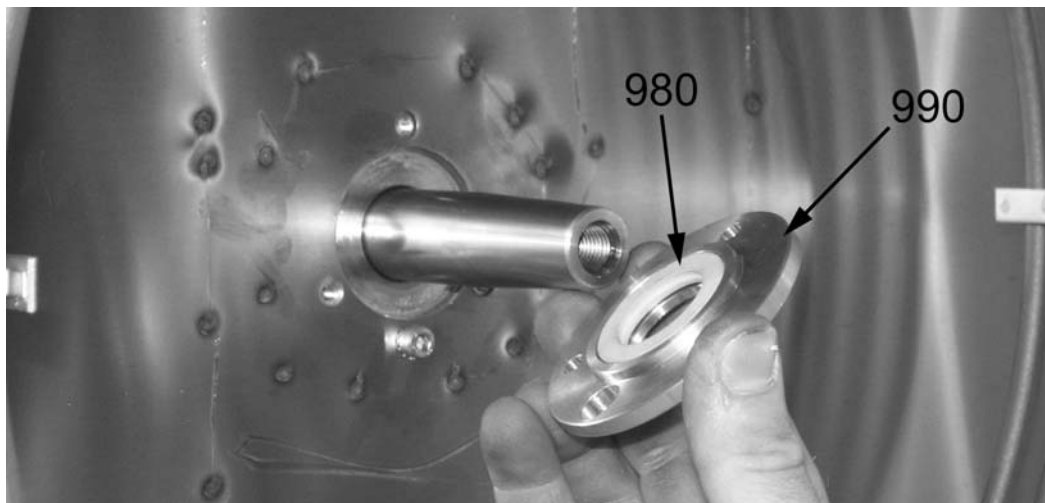

vsezip.ru

ID	Model	Type	Voltage	Description	P-code
Module: Motor oil seal					
980		6,10,20		Motor oil seal	3102400
980		21		Motor oil seal	3102400
990		6,10,20		Motor oil seal holder	3102500
990		21		Motor oil seal holder	3102500

ECVME=ELECTRIC COMBIMIX: ECVM6ES2, ECVM10ES2, ECVM20ES2, ECVM21ES2, ECVPE=ELECTRIC COMBIPLUS: ECVPE6ES2, ECVPE10ES2, ECVPE20ES2, ECVPE21ES2

6=6, 10=10, 20=20, 21=21

A=3/N/PE~400/230V 50Hz, H=3/PE~230V 50Hz, P=1/N/PE~220-240V 50Hz



vsezip.ru

+7(812)987-08-81

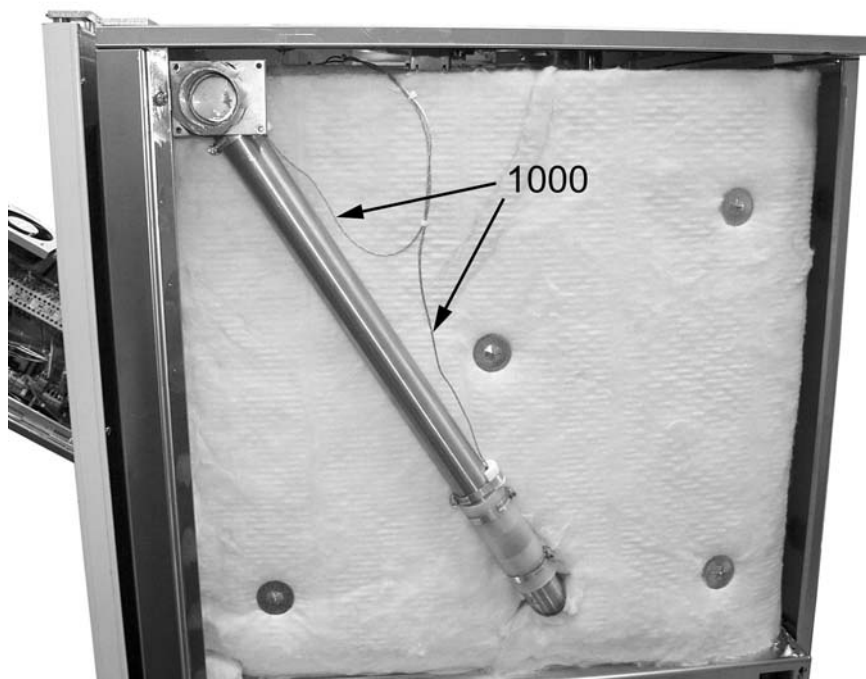

vsezip.ru

ID	Model	Type	Voltage	Description	P-code
Module: Moisture control thermocouple					
1000				Moisture control thermocouple	3103283

ECVME=ELECTRIC COMBIMIX: ECVM6ES2, ECVM10ES2, ECVM20ES2, ECVM21ES2, ECVPE=ELECTRIC COMBIPLUS: ECVPE6ES2, ECVPE10ES2, ECVPE20ES2, ECVPE21ES2

6=6, 10=10, 20=20, 21=21

A=3/N/PE~400/230V 50Hz, H=3/PE~230V 50Hz, P=1/N/PE~220-240V 50Hz

vsezip.ru

+7(812)987-08-81

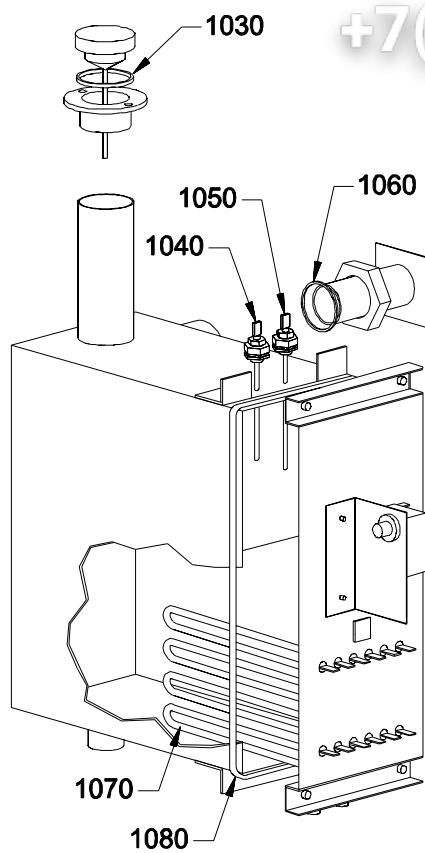

vsezip.ru

ID	Model	Type	Voltage	Description	P-code
Module: Steam generator					
1030				Gasket for safety valve	3116330
1040				Max. level sensor	A037482
1050				Min. level sensor	A037481
1060				O-ring	3116430
1070		6		Heating element 7500 W	A037483
1070		10,20,21		Heating element 15000 W	A037484
1080				Gasket	A037485

ECVME=ELECTRIC COMBIMIX: ECVM6ES2, ECVM10ES2, ECVM20ES2, ECVM21ES2, ECVPE=ELECTRIC COMBIPLUS: ECVP6ES2, ECVP10ES2, ECVP20ES2, ECVP21ES2

6=6, 10=10, 20=20, 21=21

A=3/N/PE~400/230V 50Hz, H=3/PE~230V 50Hz, P=1/N/PE~220-240V 50Hz



vsezip.ru

+7(812)987-08-81

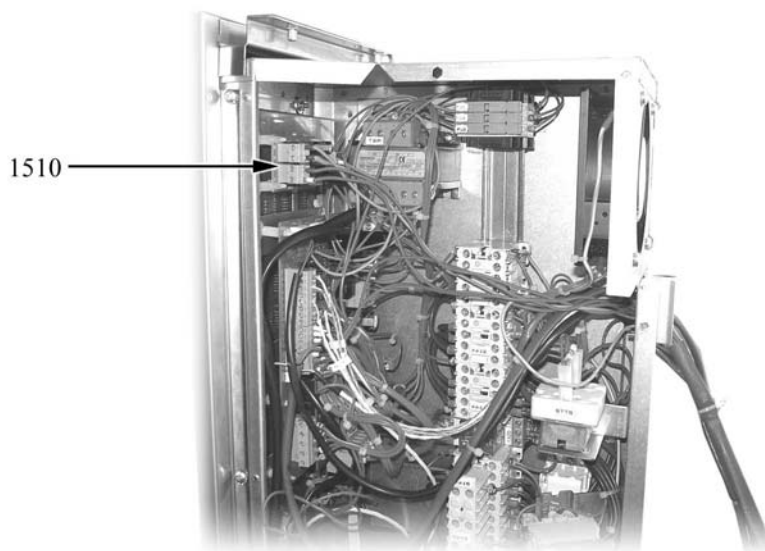
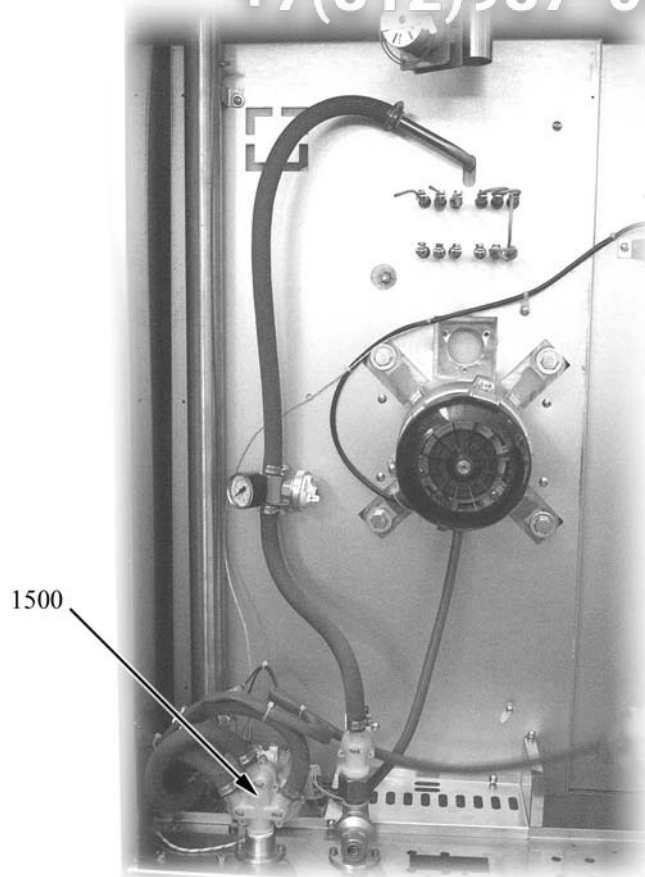

vsezip.ru

ID	Model	Type	Voltage	Description	P-code
Module: Automatic washer					
1500	ECVME			Solenoid valve, flushing 3V	3103621
1500	ECVPE			Solenoid valve, flushing 4V	3103622

ECVME=ELECTRIC COMBIMIX: ECVM6ES2, ECVM10ES2, ECVM20ES2, ECVM21ES2, ECVPE=ELECTRIC COMBIPLUS: ECVP6ES2, ECVP10ES2, ECVP20ES2, ECVP21ES2

6=6, 10=10, 20=20, 21=21

A=3/N/PE~400/230V 50Hz, H=3/PE~230V 50Hz, P=1/N/PE~220-240V 50Hz



vsezip.ru

+7(812)987-08-81

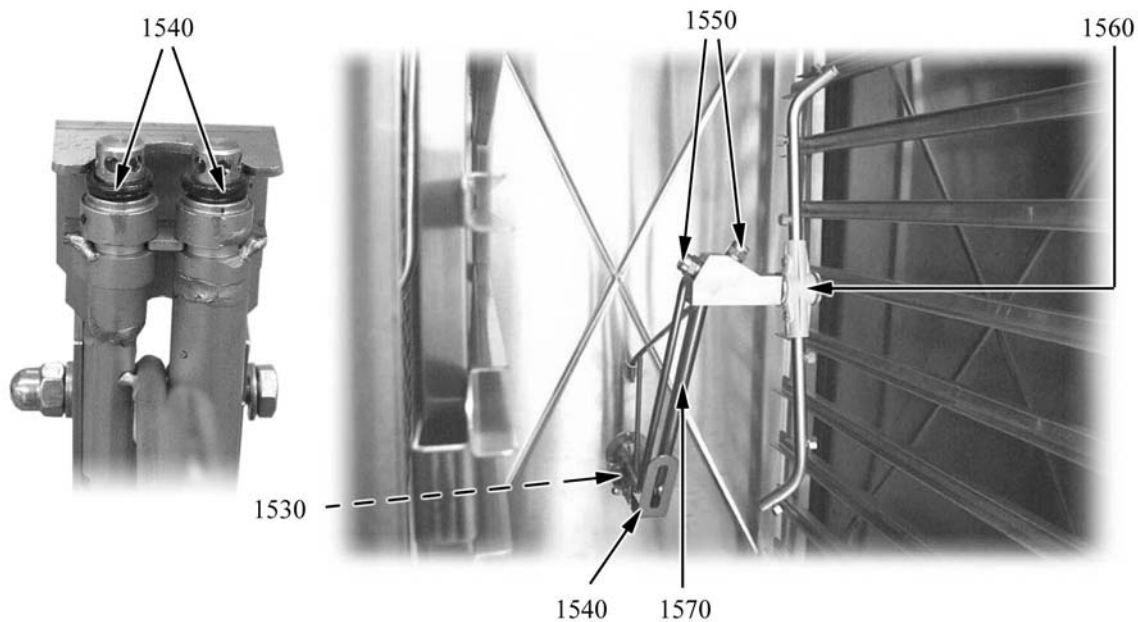

vsezip.ru

ID	Model	Type	Voltage	Description	P-code
Module: Automatic washer 2					
1510				Expansion electronic card	3103235
1520				Pomp	3103591
1530				Spring	6A010320
1540				Lever	3116850
1550				Nozzle	6A020589
1560				Pump rotor	3199350
1570				Washing system	3116700
1580					6A020594

ECVME=ELECTRIC COMBIMIX: ECVM6ES2, ECVM10ES2, ECVM20ES2, ECVM21ES2, ECVPE=ELECTRIC COM-
BIPLUS: ECVP6ES2, ECVP10ES2, ECVP20ES2, ECVP21ES2

6=6, 10=10, 20=20, 21=21

A=3/N/PE~400/230V 50Hz, H=3/PE~230V 50Hz, P=1/N/PE~220-240V 50Hz



Зип Ощепит

vsezip.ru

SPARE PART LIST



1326180 - ECVP 6E S2 LAV PLUS DI SPI.ELETTRON 81

2510675	CHIMNEY PROFILE GASKET B.844	1
3100700	EL. OVEN CHAMBER ENSEMB. 6 1/1	1
3101020	ASS. PANNEL.COPRI VENT.GRIGL.61/1\$\$	1
3101600	16 FAN WITH 16 BLADES 1/1	1
3102250	LH FAN FIX. SCREW M12X1.5	1
3102335	RELIEF VALVE 230/50-60HZ	1
3102350	COOLING FAN NMB 120X120	1
3102400	MOTOR OIL SEAL URF-B24-108-10-C	1
3102500	MOTOR OIL SEAL HOLDER	1
3102860	SIEMENS CAP 16 HOLES SIEM3SB29083A	1
3103235	SCHEDA ESPANS.LAVAGGIO F.ELETTRON\$\$	1
3103238	DISTANZIALI M-F OTTONE NIC M3x8	1
3103239	TAPPO PER PORTA SERIALE \$\$	1
3103240	DISTANZIALI PERSCHEDA0502.800.159\$\$	1
3103246	SCHEDA SERIALE PER HACCP. \$\$	1
3103249	ELECTRONIC OVEN BASIC CARD	1
3103251	ELECTRONIC OVEN BOARD	1
3103266	BUZZER FOR ELECTRONIC BOARD	1
3103267	ENCODER ELECTRONIC BOARD	1
3103268	CAVO COLLEG.SCHEDA BASE ETASTIERA\$\$	1
3103275	CHAMBER PROBE PT100CLB 6X80+4X20	1
3103280	CORE PROBE PT100CLB PIEG. 90°	1
3103281	TERMOC.TIPO K ISOLATA GUAINA diam.4	1
3103282	DRAIN THERMOCOUPLE	1
3103283	HUMIDITY CONTROL THERMOCOUPLE	1
3103285	TRIPOLAR PANEL CONNECTOR	1
3103290	CAP FOR PANEL CONNECTOR	1
3103300	STEAM GENERATOR 7.5 KW 400V	1
3103590	MOTORIZED VALVE 3/4" MOD. TCR 230V	1
3103610	ELECTRO-VALVE STEAM AND HUMIDITY	1
3103622	ELETTROVALVOLA 4V LAVAGGIO PLUS \$\$	1
3103631	OVEN PRESSOSTAT CONNECTION	1
3103635	INDUCT.PIPE 10X19 EPDM INT. WHITE	1
3103637	GREEN HUMID. LOAD.REDUCER	1
3103642	BOILER BLACK LOAD.REDUCER	1
3103643	BOILER RED FLOW REGULATOR	1
3103644	OVEN FUMES COND. NOZZLES	1
3106300	OVEN DOOR CONTAINER ENS. 6-10 1/1	1
3106355	OVEN DOOR CONT. CAP SET	1
3106670	SQ. REGGI MAGNETE PORTA FORNO \$\$	1
3106700	OVEN DOOR UPPER HINGE	1
3106800	OVEN DOOR LOWER HINGE	1
3107900	OVEN DOOR HANDLE COMPONENTS	1
3107910	DOOR CLOSING STRIKING PLATE	1
3107911	RISCONTRO CHIUSURA PORTA \$\$	1
3107915	OVEN DOOR HANDLE STOP	1
3107920	OVEN DOOR HANDLE CONIC SECTION	1

3107925	OVEN DOOR HANDLE GRIP	1
3107930	OVEN HANDLE STOP ROT. HOOK	1
3107935	OVEN CLOSING SPHERE TRACK STOP	1
3107941	OVEN HANDLE BRACKET RING 2.6	1
3107945	HANDLE ROT. STRIKING BRACKET	1
3107950	SPHERE TRACK STOP FIXING SCREW	1
3107953	HANDLE INNER SPRING SEPARATION	1
3107955	DOOR HANDLE SPRING	1
3108300	INNER OVEN DOOR GLASS 6 1/1	1
3108600	OVEN DOOR GASKET 6 1/1	1
3108850	HALOGEN LAMP 300°GH 20W 12V	1
3108860	LAMP HOLDER 218SB F90	1
3108879	OVEN DOOR CONTACT ASSEMBLY	1
3108890	END MAGNET 340PFGB0M00	1
3110500	OVEN BACK PANEL 6 1/1	1
3111100	LH OVEN SIDE PANEL 6 1/1	1
3111950	ELEMENTO FILTRANTE FORNO 6-10-20 \$\$	1
3116020	EXT.CHAMB.WATER PIPE 12 P.GRI.	1
3116120	INNER CHAMB.WATER PIPE 14 6 1/1	1
3116330	STEAMER SAFETY VALVE GASKET	1
3116430	STEAMER CONNECT. O-RING	1
3116500	BRACCIO DXGIRANTELAV.FORNI6-10-20\$\$	1
3116510	BRACCIO SXGIRANTELAV.FORNI6-10-20\$\$	1
3116600	PART.MASCHIO VALVOLA NRLAVAGGIO F\$\$	1
3116610	PART.FEMMINA VALVOLA NRLAVAGGIO F\$\$	1
3116620	PERNO PER MOZZO LAVAGGIO FORNO \$\$	1
3116630	FLANGIA ATTACCHI RAPIDLAVAGGIO F\$\$	1
3116640	TAPPO FLANGIA ATT.RAPIDI LAV.FOR.\$\$	1
3116740	COND. DIAM.8 DETERSIVO LAVA.6 1/1\$\$	1
3116750	COND.DIAM.12 ACQUA LAVAGGIO 6 1/1\$\$	1
3196000	ASSEMBLED OVEN DOOR 6 1/1	1
3199001	OVEN DOOR EXT. GLASS KIT 6 BLUE	1
6A009190	GRANI 4X10 A2	1
6A011409	S/S SPHERE D.7.9 MM	1
6A011607	OLIVE RING CONNEC. DIAM.6 0958031	1
6A016110	NUT FOR OLIVE RING DIAM. 4 TAP PEL	1
6A016120	OLIVE RING OF 4 TAP PEL	1
6A020225	RUBBER PIPE HOLDER 1/2 M D.16 BRA	1
6A020280	CURVE DIAM. 50 90° OVEN OUTLET	1
6A020584	RONDELLA RAME D.14 14x20x1.5	1
6A020586	RACC.MASCHIO 1/4"x12+OGIVA METALLO	1
6A020587	RACC.MASCHIO 1/4"x08+OGIVA METALLO	1
6A020588	O. RING INNESTO RAPIDO 7x2.5 VITON	1
6A020589	ATOMIZZ.IDR. I-1/4 MX-4 LAV. FORNO	1
6A020590	GIRANTE RISCIAQUO LAVAGGIO FORNO	1
6A020591	VITE RISCIAQUO LAVAGGIO FORNO	1
6A020592	UGELLO RISCIAQUO LAVAGGIO FORNO	1
6A020593	VALVOLINA RITENUTA X LAVAGGIO FORNO	1
6A020594	SGANCIO A PULSANTE ATTACCO MASCHIO	1
6A020595	DADO BLOCCAGGIO	1
6A020596	INNESTO A CALZAMENTO C/MOLLA	1
6A020597	INNESTO A CALZAMENTO A T CENTRALE	1
6A020598	INNESTO A CALZAMENTO DIRITTO FEMM.	1
6A023210	SILICON GASKET F/OUTLET ELECTR.OVEN	1

6A023211	DEHUMID.VALVE GASKET EL.OVEN	1
6A028610	S/S LEGS 2 X180	1
6A028620	SLEEVE FOR OVENS 2 X130 FL.82X82	1
6A037460	HEAT.EL.7500W 230V OVEN	1
6A038550	INT.A PULSANTE 2P IP55 A4408291K3	1
6A040665	TUBO SILICONE NATURALE 4X8	1
6A047085	MICROSWITCH REED E5201BDA0070	1
8219600	TAPPO PER TERMOSTATO SIC. CPE 70/02	1

[» print «](#)