

Зип Общепит   
**Wexiödisk**  
vsezip.ru

+7(812)987-08-81  
**DISHWASHER**  
**WD-4**

(translation of the original documentation)

---

## Spare parts manual

---



4\_01

---

S/N:

Valid from: 01. 02. 2012

Rev.: 2.0

---

**Зип Общепит**

**vsezip.ru**

**+7(812)987-08-81**

vsezip.ru

+7(812)987-08-81

## 1. Spare parts

External details .....	3
Water connections	
booster heater.....	5
Booster heater 400V 3kW .....	7
Booster heater 230V 9KW (option) .....	9
Booster heater 400V 9kW (option) .....	11
Booster heater 440V 9kW (option) .....	13
Rinse system.....	15
Tank details .....	17
Door .....	21
Emptying pump (option) .....	23
Breaktank (option) .....	25
Electrical components .....	27
Pump 1217 .....	29
Sorting bench (option) .....	31

vsezip.ru

+7(812)987-08-81

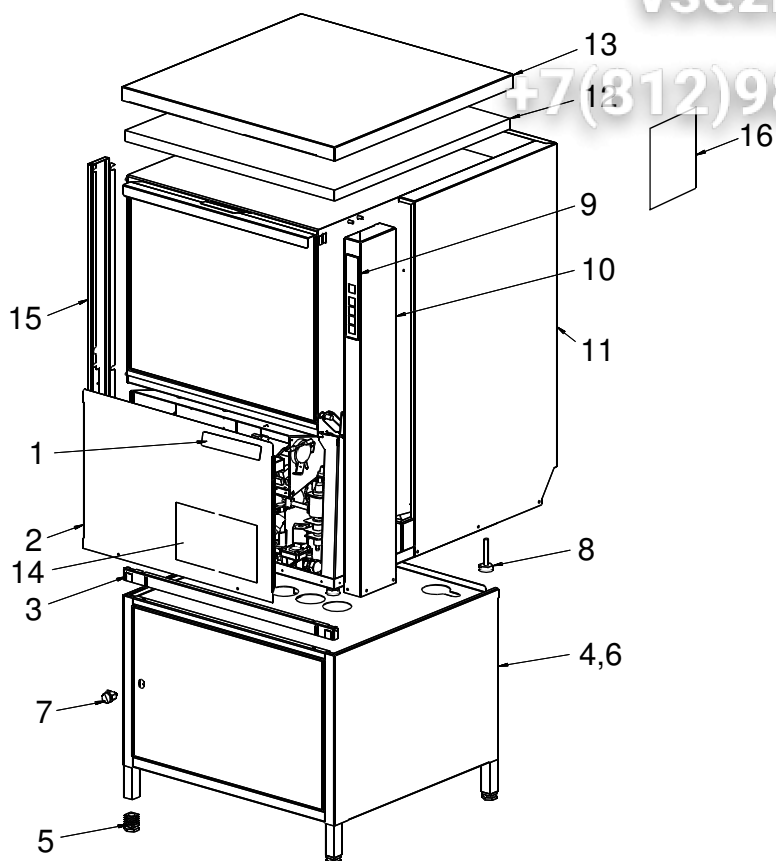

39697\_r4

vsezip.ru

ID	M art.no	Description	W art.no
<b>Module:External details</b>			
1		Model sign WD	w45941,31
1		Model sign Metos	w42749,31
1		Model sign Rhima	w43883,31
2		Front plate W	w45107,31
2		Front plate	w45107,32
3		Cover plate, front side	w45411,31
4		Bottom frame without door	w201,0556
5		* Plastic foot adjustable VJ25-25	w718,0103
6		Bottom frame, lockable, Cpl	w201,0557
5		* Plastic foot adjustable VJ25-25	w718,0103
7		* Cylinder lock CP610 chrome	w792,0101
8		Adjustable foot 29x12 M10x60	w718,0106
9		Panel sign	w300802,31
9		Panel sign Metos	w300834,31
9		Panel sign ep.	w300806,31
9		Panel sign ep Metos	w300835,31
10		Side pillar	w301735,01
		Cover plates	w740,0503
11		* Cover plate	w301734,31
12		* Cellular plastic 595x595x25	w46285,31
13		* Cover plate, roof	w39430,31
		* Insulating	w41429,31
14		Plastic case A4	w724,0502
15		Side pillar	w301733,31
16		Quick guide to WD-4 without drain pump	w724,6014
16		Quick guide to WD-4 with drain pump (option)	w724,6015

vsezip.ru

+7(812)987-08-81

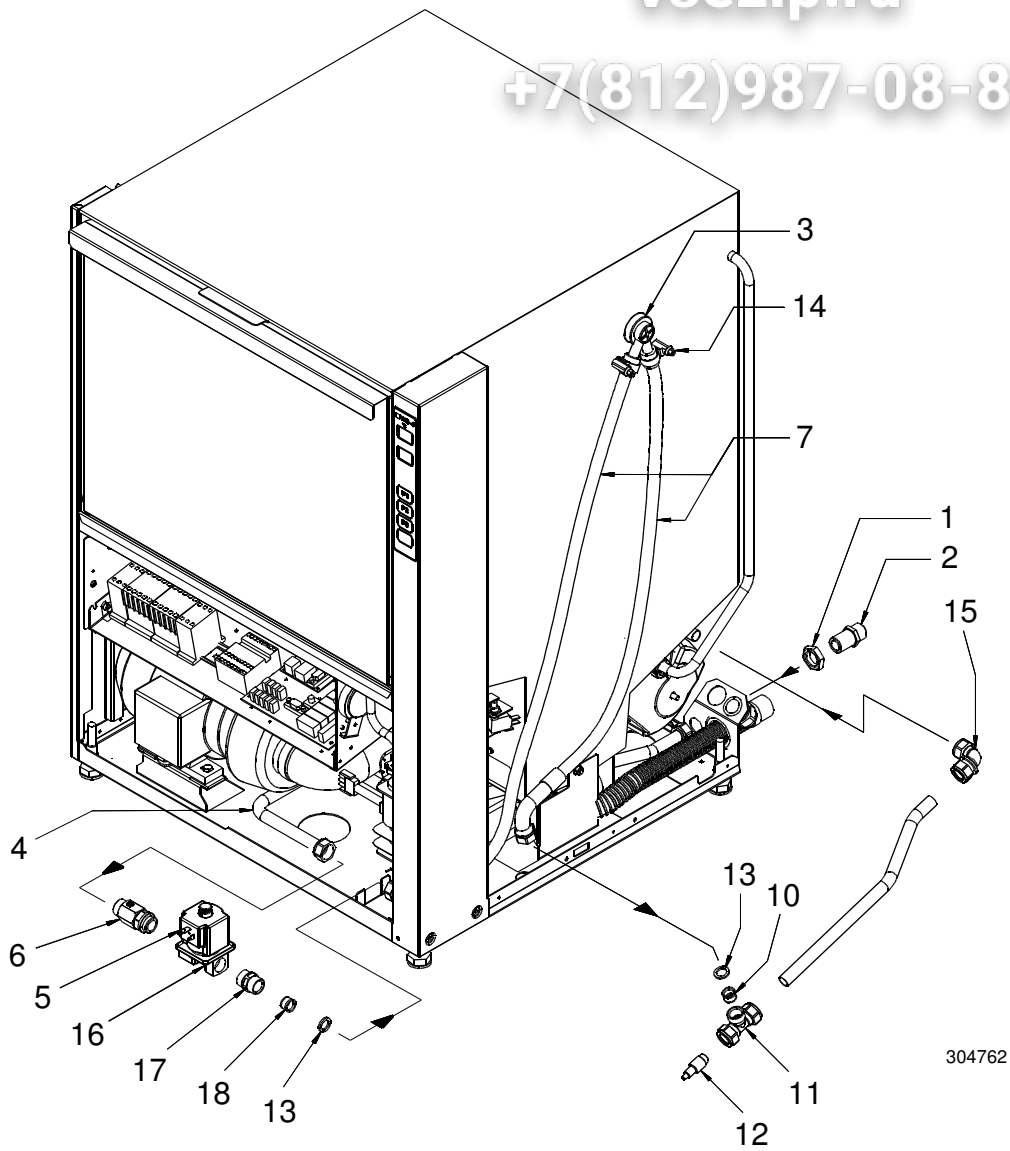

vsezip.ru

ID	M art.no	Description	W art.no
Module:Water connections booster heater			
1		Nut R 1/2"	w706,0203
2		Nipple	w46446,31
3		Vacuum valve	w709,1509
4		Pipe	w28362,01
5	5315767	Coil 24V/50Hz 10W	w729,1519
6		Ball valve	w709,0809
7		Steel braided hose L=790	w47286,01
8		Coupling 15x15	w705,0914
		* Clamping sleeve 15mm	w705,0420
		* Nut 15mm	w705,0315
9		Pipe	w47418,31
10		Reducing	w709,0820
11	5320000	Coupling 15mm, brass	w705,2205
		* Clamping sleeve 15mm	w705,0420
		* Nut 15mm	w705,0315
12		Connection nipple	w45985,31
13	5320975	Packing 1/2"	w701,0122
14		Hose clamp	w714,0103
15		Coupling, angeled 15xR15	w705,1609
		* Clamping sleeve 15mm	w705,0420
		* Nut 15mm	w705,0315
16	5320318	Solenoid valve, housing EVSI-12	w729,1540
17		Coupling	w705,0920
18		Reducing	w709,0820

vsezip.ru

+7(812)987-08-81

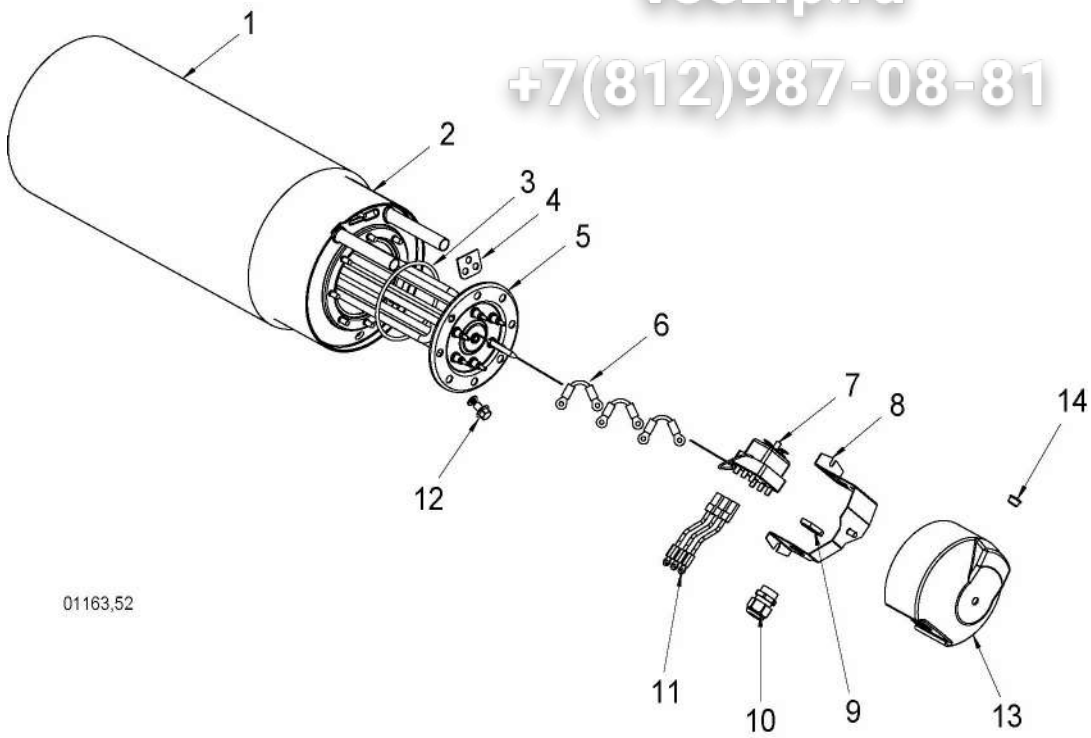

01163,52



vsezip.ru

ID	M art.no	Description	W art.no
Module: <b>Booster heater 400V 3kW</b>			
		Booster heater 400V 3kW	w01163,52
1		* Heat insulation booster heater	w809,0903
2	5320267	* Container booster heater (E)	w01162,04
3	5315689	* O-ring 90x4.0	w719,1090
4		* Attachment temp.sensor	w44203,31
5	5315199	* Element 9kW 230/400V	w30835,01
6		* Cable bridge	w670,8240
7		* Overheating protection 120°C	w734,0110
8		* Holder verheating protection 20 mm	w301365,01
9		* Locking nut M20	w51471532
10		* Cable screw cap M20x1,5	w51471503
11		* Coupling conductor	w670,8244
12		* Collar screw 8x12 A2 + Gasket	w700,2501
13		Protection cover	w301321,31
14		End plug M12	w51476571

vsezip.ru

+7(812)987-08-81

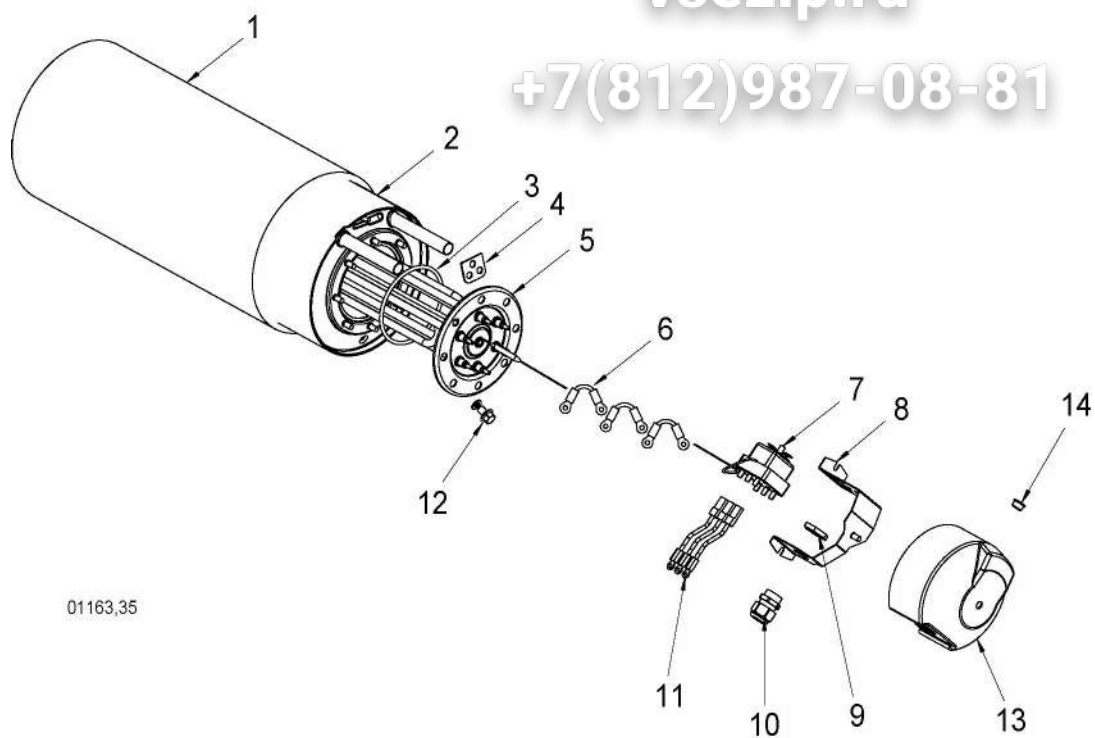

01163,35

vsezip.ru

ID	M art.no	Description	W art.no
Module: <b>Booster heater 230V 9KW (option)</b>			
		Booster heater 230V 9KW	w01163,35
1		* Heat insulation booster heater	w809,0903
2	5320267	* Container booster heater (E)	w01162,04
3	5315689	* O-ring 90x4.0	w719,1090
4		* Attachment temp.sensor	w44203,31
5	5315199	* Element 9kW 230/400V	w30835,01
6		* Cable bridge	w67182105
7		* Overheating protection 120°C	w734,0110
8		* Holder verheating protection 20 mm	w301365,01
9		* Locking nut M20	w51471532
10		* Cable screw cap M20x1,5	w51471503
11		* Coupling conductor	w670,8244
12		* Collar screw 8x12 A2 + Gasket	w700,2501
13		Protection cover	w301321,31
14		End plug M12	w51476571

vsezip.ru

+7(812)987-08-81

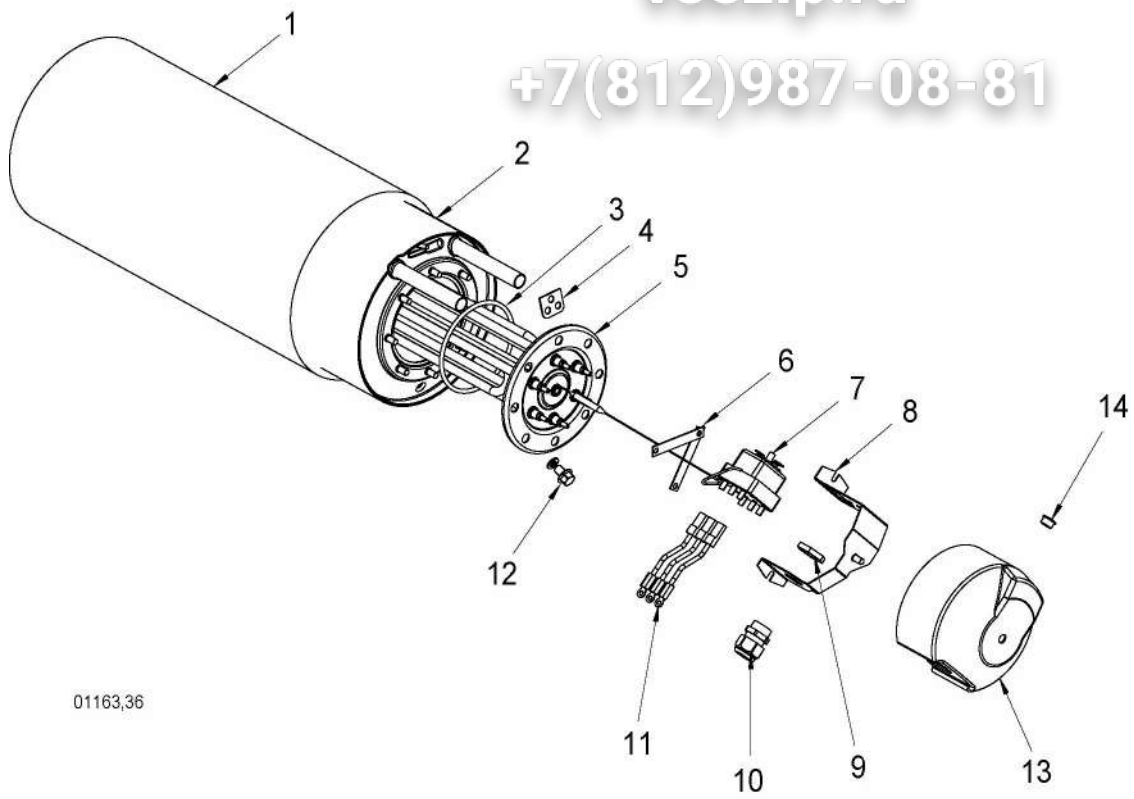

01163,36

vsezip.ru

ID	M art.no	Description	W art.no
Module: <b>Booster heater 400V 9kW (option)</b>			
		Booster heater 400V 9kW	w01163,36
1		* Heat insulation booster heater	w809,0903
2	5320267	* Container booster heater (E)	w01162,04
3	5315689	* O-ring 90x4.0	w719,1090
4		* Attachment temp.sensor	w44203,31
5	5315199	* Element 9kW 230/400V	w30835,01
6	5320276	* Copper clamp	w04920,31
7		* Overheating protection 120°C	w734,0110
8		* Holder verheating protection 20 mm	w301365,01
9		* Locking nut M20	w51471532
10		* Cable screw cap M20x1,5	w51471503
11		* Coupling conductor	w670,8244
12		* Collar screw 8x12 A2 + Gasket	w700,2501
13		Protection cover	w301321,31
14		End plug M12	w51476571

vsezip.ru

+7(812)987-08-81

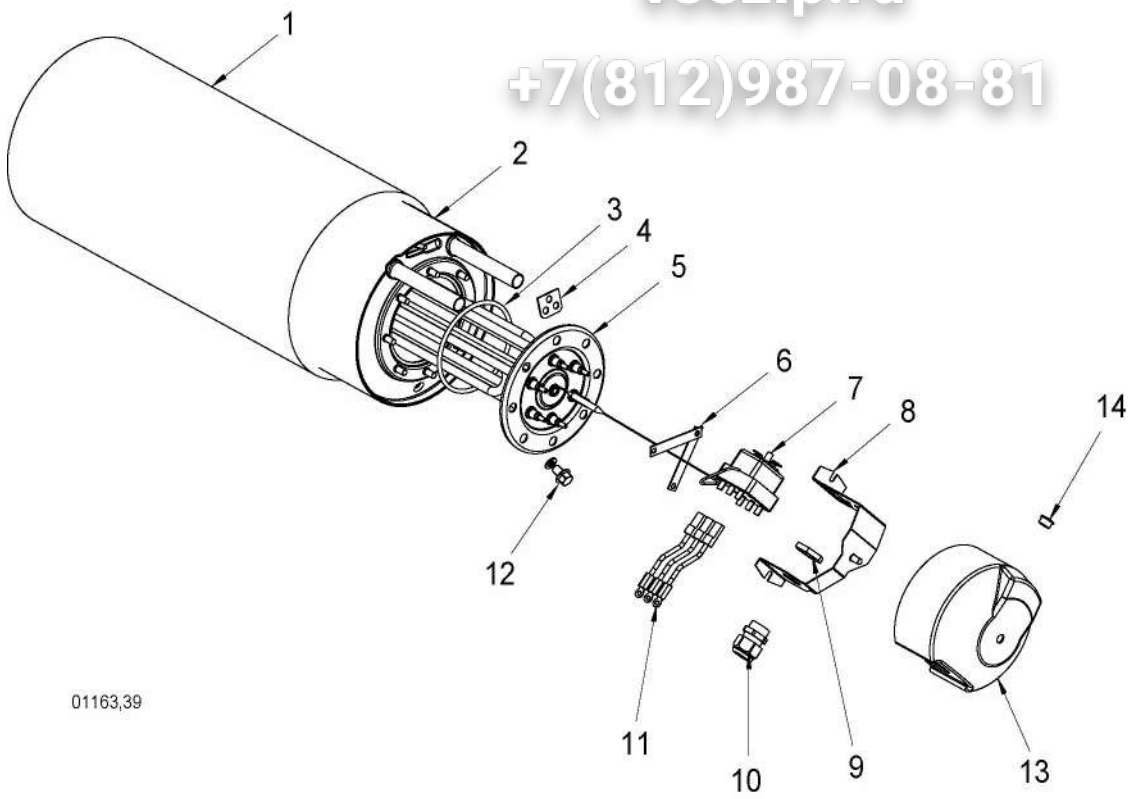

01163,39

vsezip.ru

ID	M art.no	Description	W art.no
Module: <b>Booster heater 440V 9kW (option)</b>			
		Booster heater 440V 9kW	w01163,39
1		* Heat insulation booster heater	w809,0903
2	5320267	* Container booster heater (E)	w01162,04
3	5315689	* O-ring 90x4.0	w719,1090
4		* Attachment temp.sensor	w44203,31
5		* Element 9kW 254/440V	w30835,18
6	5320276	* Copper clamp	w04920,31
7		* Overheating protection 120°C	w734,0110
8		* Holder verheating protection 20 mm	w301365,01
9		* Locking nut M20	w51471532
10		* Cable screw cap M20x1,5	w51471503
11		* Coupling conductor	w670,8244
12		* Collar screw 8x12 A2 + Gasket	w700,2501
13		Protection cover	w301321,31
14		End plug M12	w51476571

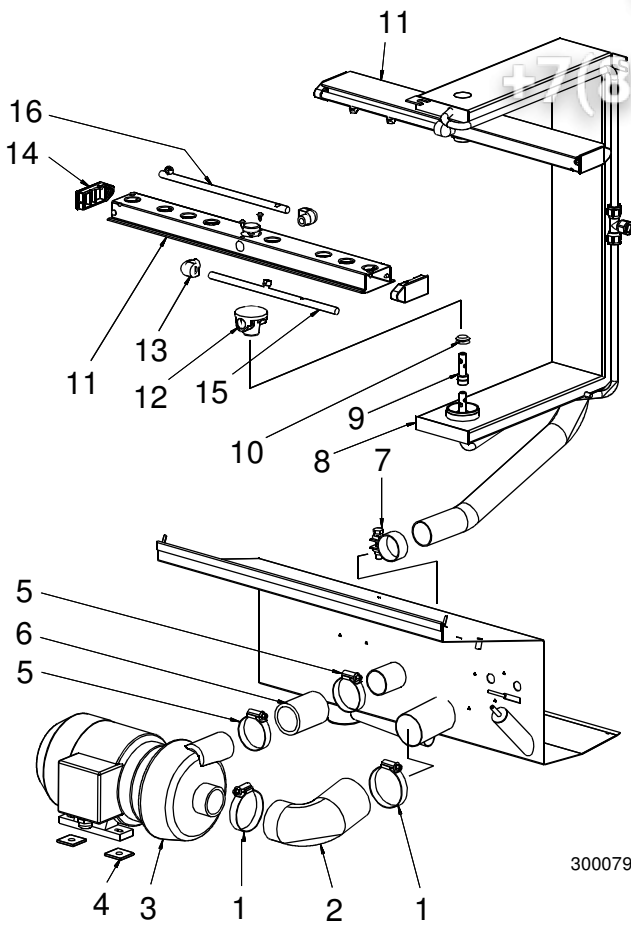

300079\_r2



vsezip.ru

ID	M art.no	Description	W art.no
<b>Module: Rinse system</b>			
1	5320026	Hose clamp 40-60/12	w714,0110
2		Rubber bend 62x57	w42728,31
3		Pump 1217	
4	5320246	Rubber foot 30x30x3	w719,1330
5	5315652	Hose clamp 32-50/12 W3	w714,0109
6		Pump connection	w43665,32
7		Clamp	w714,0123
8		Main pipe	w26546,01
9	5320950	Neck	w44600,31
10	5315681	V-ring V16S	w719,0111
11		Rinse arm, complete	w26459,01
12	5320942	* Rinse arm bearing, complete	w38181,75
		** Rinse arm bearing	w38181,31
		** Locking screw rinse arm	w45569,31
		** Locking nut rinse arm	w45568,31
13	5320941	* Rinse pipe attachment	w44969,31
14		* End cover	w38719,31
15		* Rinse pipe, complete	w47004,01
16		* Rinse pipe, complete	w47004,02

vsezip.ru

+7(312)987-08-81

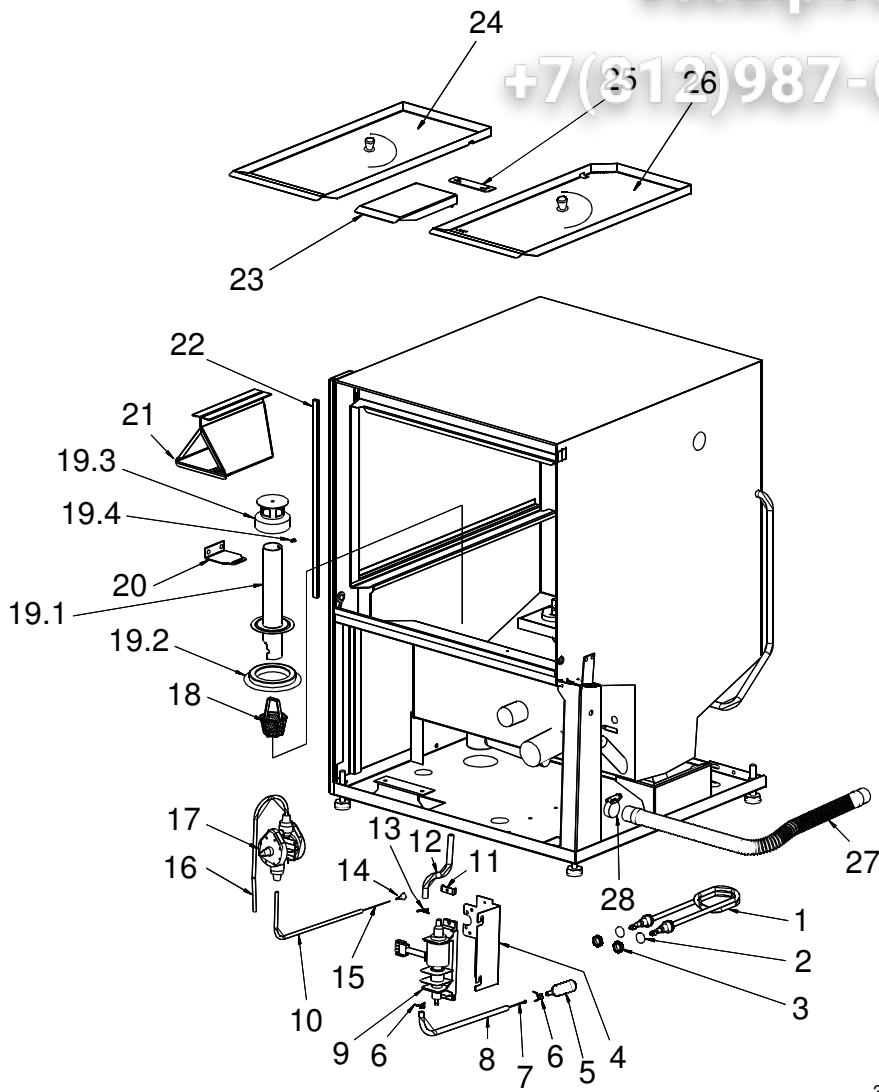

39729\_R2

vsezip.ru

ID	M art.no	Description	W art.no
<b>Module: Tank details</b>			
1	5315388	Element 1800W 230V	w604,1805
2		Packing	w604,0014
3		Nut for element, M14	w604,0013
4		Attachment (option)	w45259,31
5	5315671	Detergent pump strainer (option)	w716,0504
6		Hose clamp Remin RSF 8-1 (option)	w714,0408
7		Reinforcement pin (option)	w42887,31
8	5315687	Hose PVC 6x9 Specify length (option)	w719,0305
9	5316075	Detergent pump GRI 14825 (option)	w716,0501
10	5315667	Hose 4x6 Specify length	w716,0402
11	5320959	Clamp (option)	w41115,31
12	5320008	Hose PVC 7-10 Specify length (option)	w719,0307
13		Hose clamp Remin RSF 11 653 (option)	w714,0411
14	5315669	Strainer	w716,0404
15		Reinforcement pin	w42946,31
16	5315672	Pressure hose 4x6	w716,0405
17	5315665	Drying agent pump N6	w716,0401
18		Outlet strainer	w44952,01
19		Level pipe	w304529,75
19,1		* Level pipe	w304528,01
19,2	5315699	* Level pipe sealing	w719,4036
19,3		* Foam remover	w41225,31
19,4		* Screw MCS M4x6 A2	w700,0607
20		Support (marin)	w45419,31
21		Pump strainer	w39016,31
22		Sealing strip 7x10 Specify length	w719,0401
23		Cover plate	w38547,31

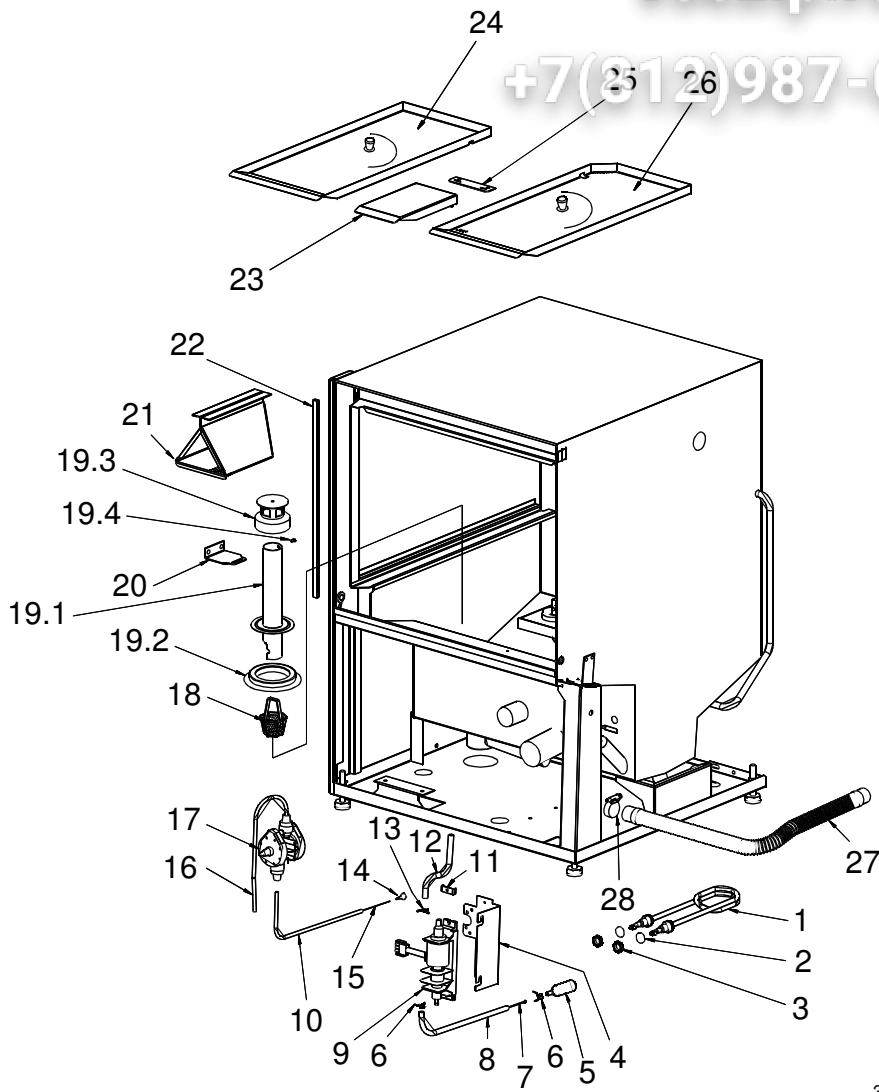

39729\_R2

vsezip.ru

ID	M art.no	Description	W art.no
24		Strainer plane, left	w304159,75
		* Nob	w718,0826
		* Screw M6SF M8x25 A2	w700,2864
25		Attachment, cover plate	w44904,31
26		Strainer plane, right	w304089,75
		* Nob	w718,0826
		* Screw M6SF M8x25 A2	w700,2864
27		Outlet hose 22 mm	w727,0401
28	5320020	Hose clamp 22-32/12	w714,0106

vsezip.ru

+7(812)987-08-81

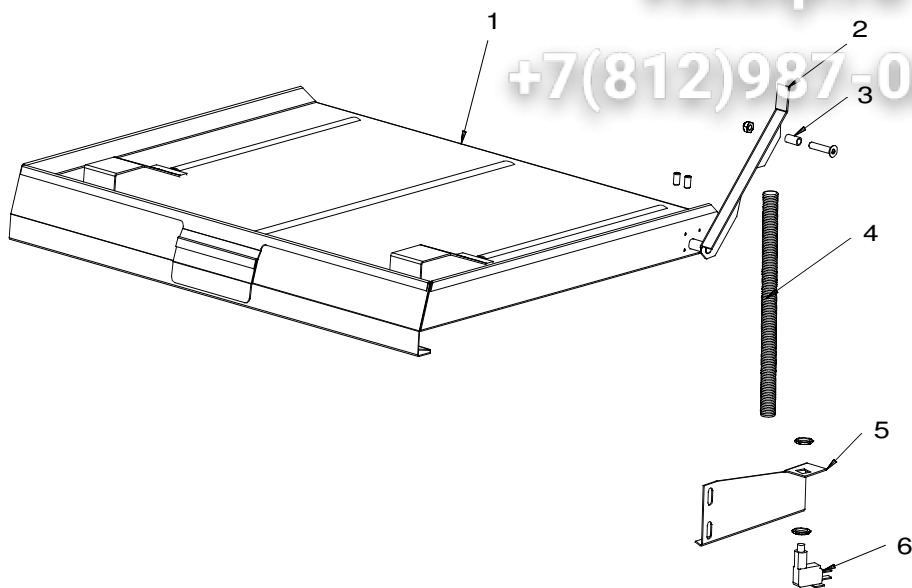

39742e

vsezip.ru

ID	M art.no	Description	W art.no
Module:Door			
1		Door	w26563,01
2		Door axle	w45600,01
3		Screw with barrel under head	w700,9901
4		Spring for insulated door	w46595,31
5		Attachment	w44891,31
6	5315380	Micro switch 83.161.3 +2 nuts	w60383161

vsezip.ru

+7(812)987-08-81

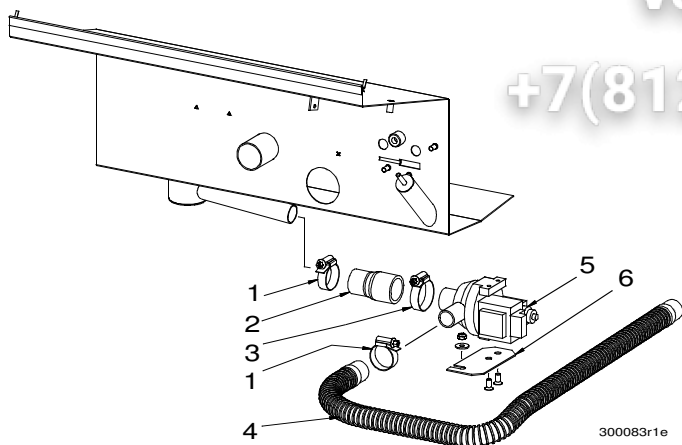

300083r1e



vsezip.ru

ID	M art.no	Description	W art.no
Module:Emptying pump (option)			
		Emptying pump	w740,0555
		Emptying pump	w740,0555B
		Emptying pump	w740,0555E
1		* Hose clamp 25-40/12 W3	w714,0106
2		* Pump connection	w45537,31
3		* Outlet hose 18mm	w727,0401
4		* Hose clamp	w714,0107
5		* Emptying pump DPS35-008 230V 50Hz	w735,0310
5		* Emptying pump DPS35-008 230V 60Hz	w735,0310A
6		* Attachment	w45781,31

vsezip.ru

+7(812)987-08-81

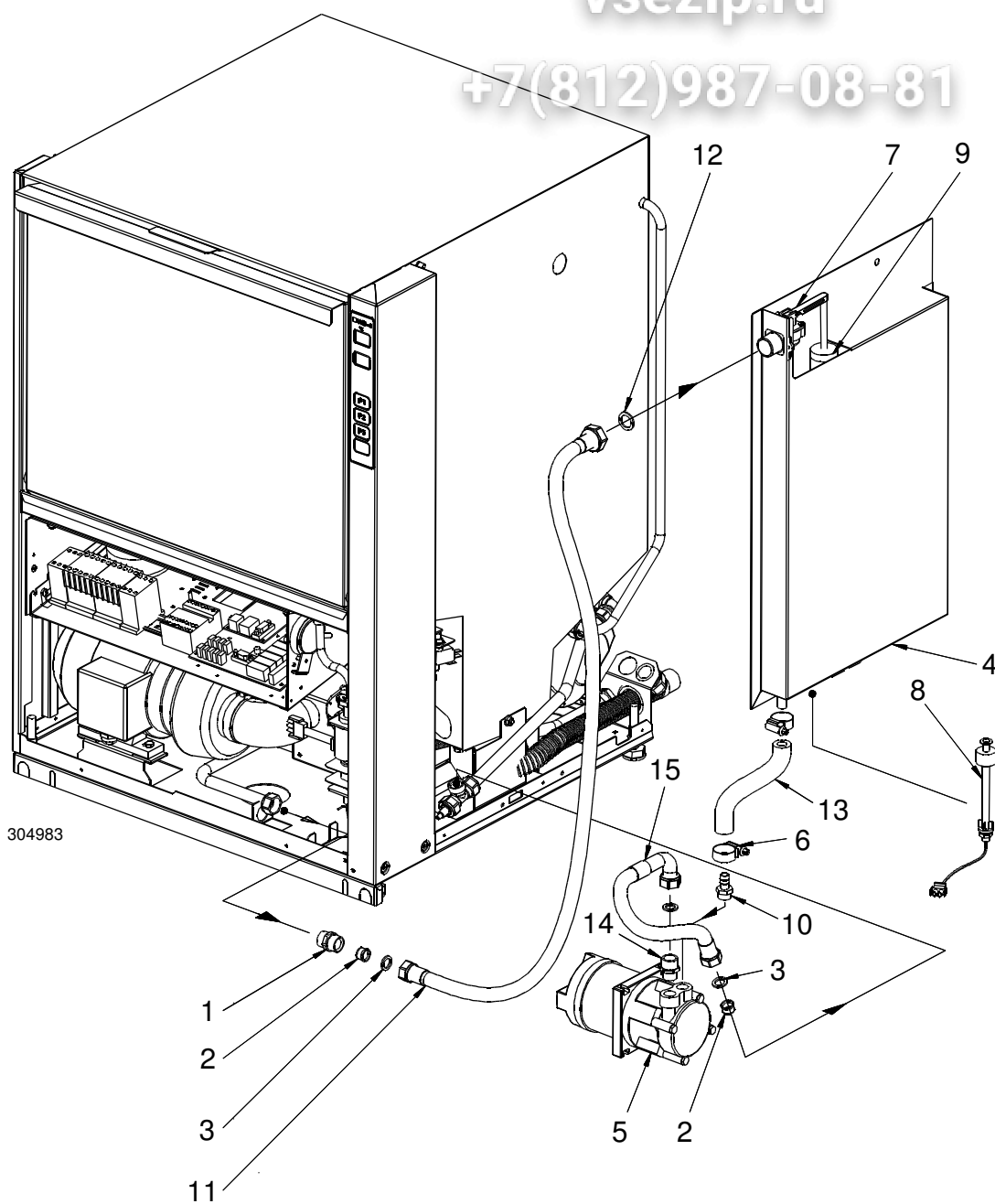

ID	M art.no	Description	W art.no
Module:Breaktank (option)			
1		Coupling 15x15	w705,0914
		* Clamping sleeve	w705,0420
		* Nut	w705,0315
2		Reducing	w709,0820
3	5320975	Packing 1/2"	w701,0122
4		Tank	w303896,01
5		Pump LGB PS46DX 230/400V/50Hz/3	w805,2540
6		Hose clamp	w714,0101
7		Float	w709,4020
8		Level guard	w733,0514
9		Float	w47287,31
10		Hose nipple	w706,1803
11		Steel braided hose	w47153,01
12		Packning 24x17x2	w701,0123
13	5320971	Hose L=200mm	w717,0301
14		Nipple 3/8x1/2"	w706,0809
15		Steel braided hose	w47139,01

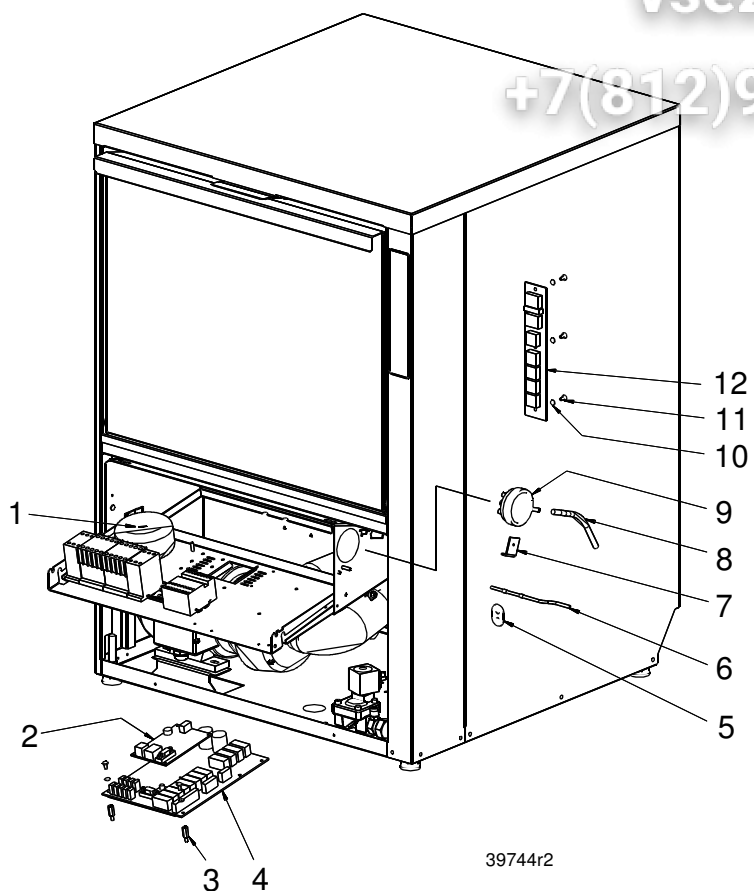

vsezip.ru

ID	M art.no	Description	W art.no
<b>Module:Electrical components</b>			
1		Transformator	w60677054
2		CPU card ESP (option)	w61103000
3		Distance nut	w702,2015
4		Computercard ESP	w61101100
5	5320151	Attachment, temp.sensor	w43106,31
6		Temp.sensor	w61111300
7		Pressure switch attachment	w04196,31
8	5320600	Hose EPDM 7x4mm L=170	w719,0310
9	5315791	Pressure switch, gold	w733,0103
10		Lock washer IZ 4.3 steel fzb	w702,1205
11		Screw MCS M4x8 A2	w700,0608
12		Panelcard ESP	w61102100

vsezip.ru

+7 (812) 987-08-81

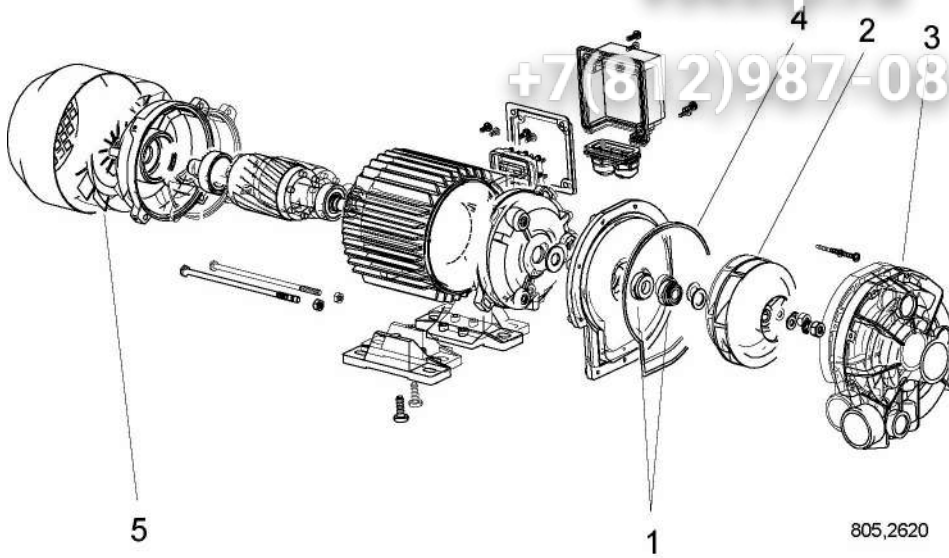

vsezip.ru

ID	M art.no	Description	W art.no
Module: <b>Pump 1217</b>			
		Pump 1217 230/400V 50Hz	w805,2620
		Pump 1217 230/400V 60Hz	w805,2620B
		Pump 1217 255/440V 60Hz	w805,2620C
		Pump 1217 23 50Hz 1-fas	w805,2620D
		Pump 1217 200V 50Hz	w805,2620E
		Pump 1217 200V 60Hz	w805,2620F
1	5315970	* Mechanical sealing	w805,2594
2		* Impeller 60Hz	w805,2623c
2	5322208	* Impeller 50Hz	w805,2623
3	5321050	* Pump house	w805,2621
4	5315969	* O-ring	w805,2595
5		* Fan	w805,2552

vsezip.ru

+7(812)987-08-81

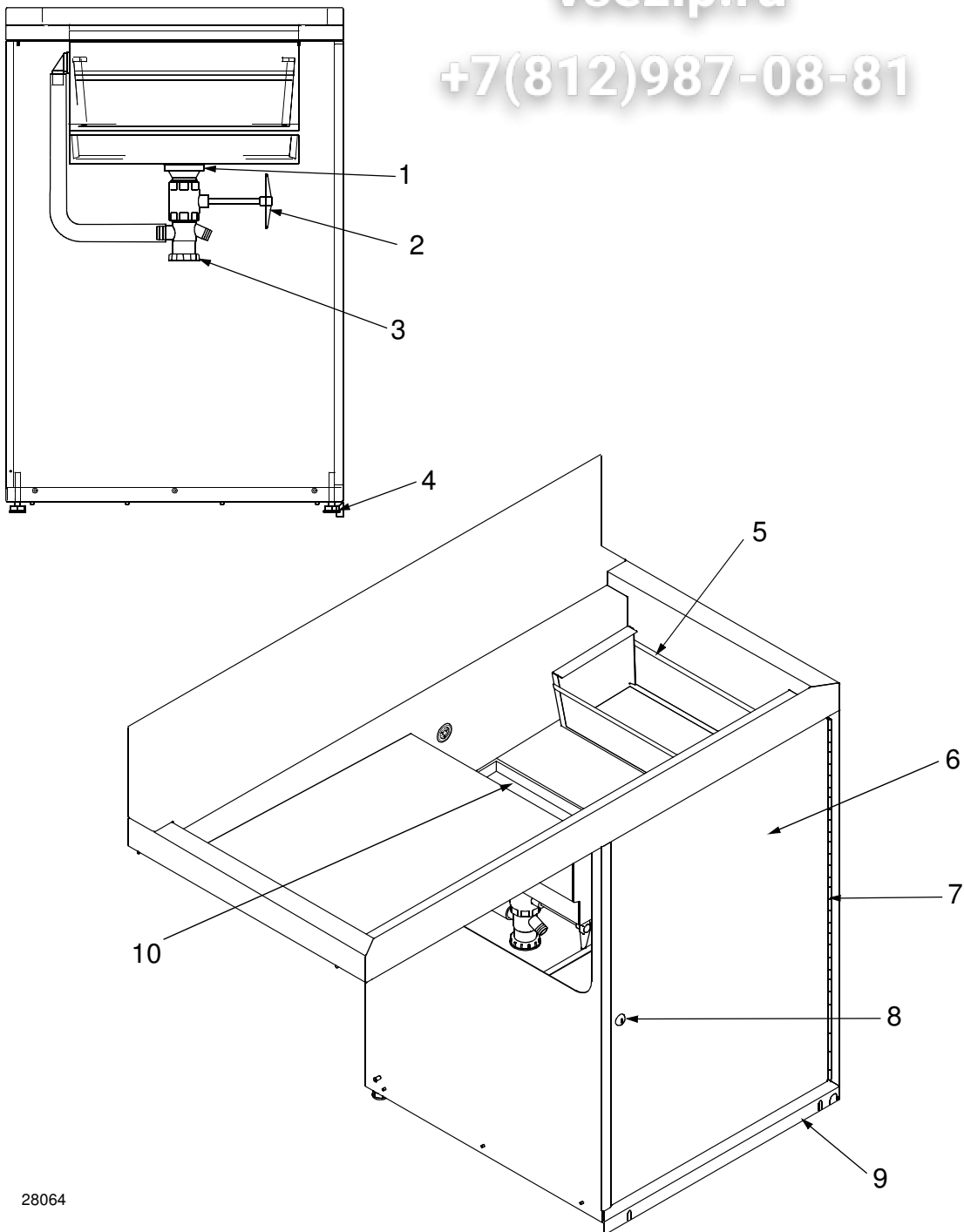

28064



vsezip.ru

ID	M art.no	Description	W art.no
<b>Module:Sorting bench (option)</b>			
		Sorting bench, right	w28064,01
		Sorting bench, left	w28064,02
1		* Sewage pipe	w726,0410
2		* Drain valve DN40	w715,0040
3		* Spillway overflow set	w726,0414
4		* Adjustable foot 29x12 M10x60	w718,0106
5		* Cutlery box sorting bench	w303287,31
6		* Door	w303547,31
7		* Piano hinge	w790,0101
8		* Cylinder lock CP610 chrome	w792,0101
9		* Cover plate, front side	w45411,31
10		* Strainer box sorting bench	w303230,31