

**cod.DW201E**

data:13/10/2021

**Catalogo ricambi  
Spare parts catalog  
Catalogue de pièces détachées  
Ersatzteilkatalog  
Catálogo de repuestos  
Catálogo de peças de reposição  
Каталог запасных частей**

**Зип Общепит**

**vsezip.ru**

**+7(812)987-08-81**

**RX164EDX HR5 DR24 DDE 380-400V/3N/50 EAC**

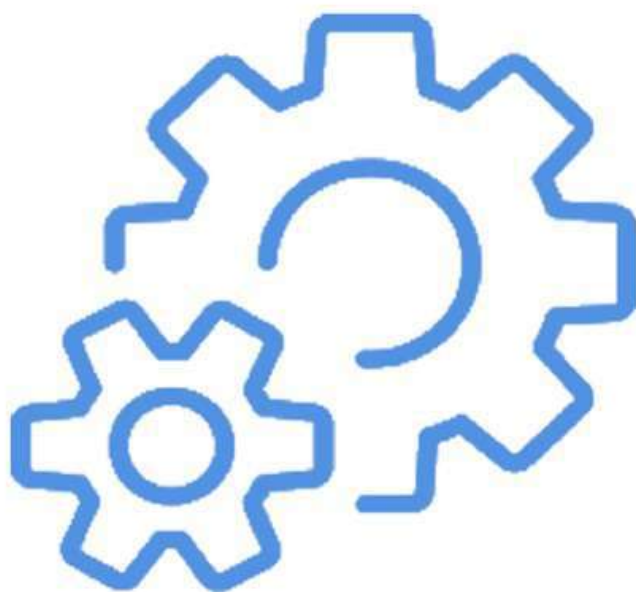

**S/N:DW01020490**



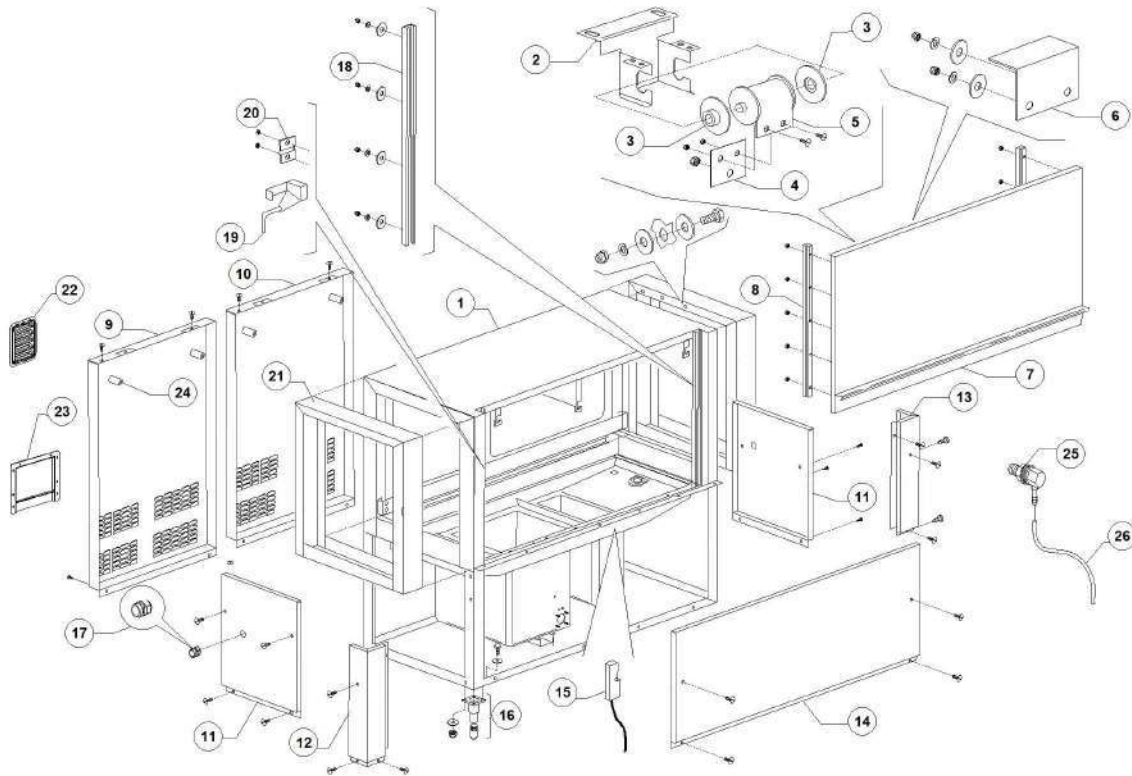

Pos.	Code	Descrizione	Description
1	DW392000/D	CARROZZERIA TUNNEL TYPE 290 DX	BODYWORK RIGHT
2	DW3009664	#STAFFA SUP.MOLLA BBSR21/23 2003 (N)	SPRING SUPPORT BRACKET BBSR21/23 2003
3	DW3004012	SPALLA SUPPORTO MOLLA PORTA	SPRING HOLDER
4	DW3009555	#PIASTRINA FIX MOLLA TRAINO AX151	SPRING CLAMPING PLATE
5	DW3004011	MOLLA INOX X PORTA MOD.BBSR23	DOOR SPRING BBSR23
6	DW3009269	#SQ.FINE CORSA PORTA	DOOR STOP
7	DW392012	#ASSIEME PORTA TYPE 92 COMPLETA	COMPLETE DOOR ASSEMBLY TYPE 92
8	DW75304	PATTINO SCORRIMENTO CAPOTTA L600	HOOD SLIDING GUIDE L600
9	DW392003	SCHIENALE SX PER TYPE 92 (3x 3071286)	LEFT BACK PANEL (3X3071286)
10	DW392002	SCHIENALE DX PER TYPE 92 (3x 3071286)	RIGHT BACK PANEL (3X3071286)
11	DW391021	SOTTOPORTA LAT. DX /SX TYPE 91-92	LATERAL FRONT PANEL
12	DW391019	ANGOLO SOTTOPORTA SX TYPE 91-92	LEFT ANGLE FRONT PANEL
13	DW391018	ANGOLO SOTTOPORTA DX TYPE 91-92	RIGHT ANGLE FRONT PANEL
14	DW392001	SOTTOPORTA ANTERIORE TYPE 92	FRONT PANEL
15	DW10778	MICROCONTATTO MAGNETICO REED	DOOR MICROSWITCH
16	DW80116	PIEDINO 2" REG. 112-215 A304"	ADJUSTABLE FOOT 112-215 2"
17	DW80416	PRESSACAPO PG16 OBO CON GHIERA	CABLE FITTING
18	DW391039	#GUIDA PATTINO PORTA TYPE 91-92	SLIDEWAYS TYPE 91-92
19	DW3000315	GANCIO SICUREZZA PORTA FX/CX	SAFETY DOOR HOOK
20	DW3000314	STAFFA SICUREZZA PORTA FX/CX	DOOR SAFETY BRACKET
22	DW25046	TAPPO CON GELOSIE	VENTILATION GRID
23	DW3071286	CARTER PER IPX4 /IPX5 ESTERNO	EXTERNAL PROTECTION IPX4/IPX5
24	DW391081	PROLUNGA FISS. SCHIENALI TYPE 91-92	FIXING BACKS EXTENSION
25	DW15123	INIETTORE DETER. A GOMITO INOX	S/S DOSING PUMP INJECTOR
26	DW14503	TUBO PVC DIAM.6x4 TRASPARENTE	D.6X4 PVC TRANSPARENT HOSE

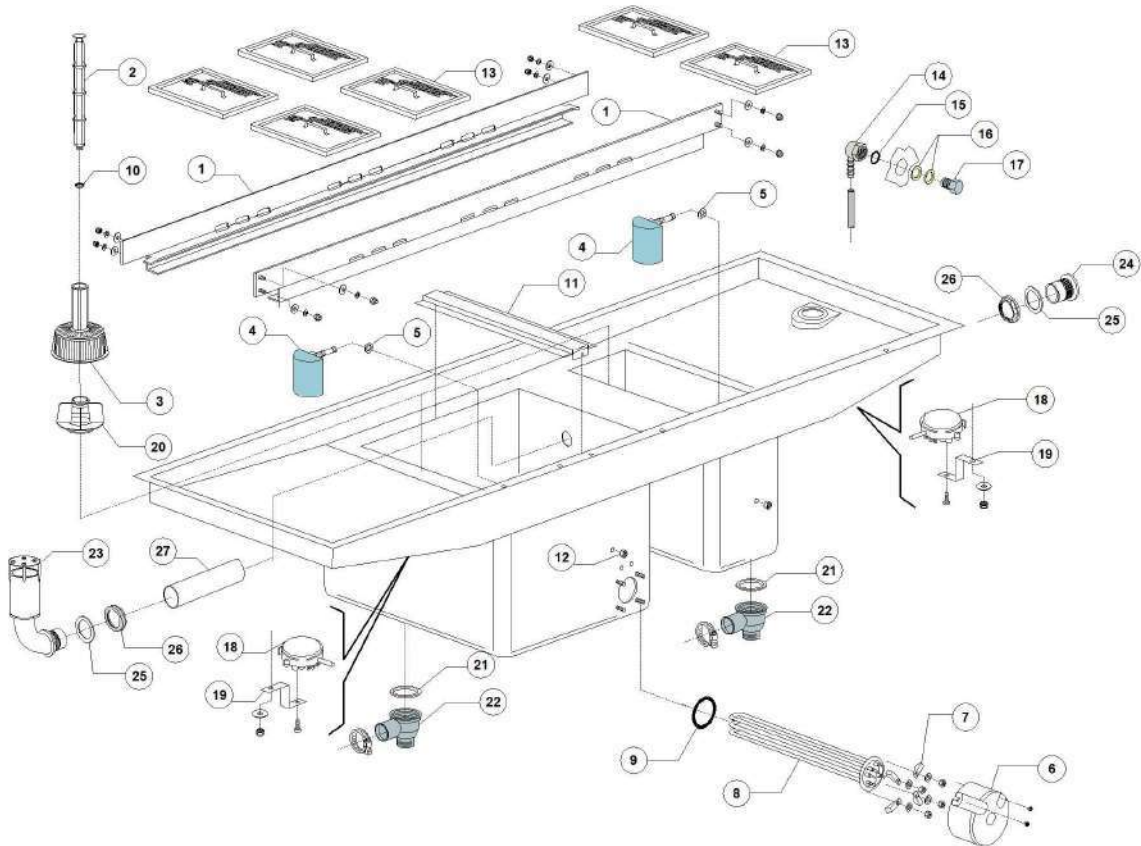

Pos.	Code	Descrizione	Description
1	DW392014	PIEG. GUIDACESTO TYPE 92	Bracket slide bar TYPE 92
1	DW392015	PIEG. TELAIO CARRELLO TYPE 92	MOBILE FRAME TYPE 92
2	DW11600102	TROPPO PIENO G12/03	OVERFLOW PIPE ASSEMBLY
3	DW500599	FILTRO ASPIR. CON PROLUNGA	SUCTION FILTER
4	DW135911	ASSIEME GABBIA D'ARIA GRIGIA L90	GREY AIR TRAP ASSEMBLY L90
5	DW13301	GUARNIZ. IN ROLMART D14x8x1,5	O-RING ROLMART D14X8X1,5 (MIN. 10 PCS)
6	DW75311	CUFFIOTTO PER RESISTENZA 26/03/97	HEATING ELEMENT COVER
7	DW16045	STAFFE FISSAGGIO RESIST.FORO 6.3	HEATING ELEMENT MOUNTING BRACKET D.6,3
8	DW30001011	RESIST.9000/9800W 230/240V 3	9000/9800W 230/240V 3 HEATING ELEM.
9	DW13015	GUARNIZIONE 6225 OR 160 NBR	6225 O-RING 160 NBR (MIN. 5 PCS)
11	DW93509	TRAVERSO CENTR.SUPP.FILTRO P4S8	CENTRAL TRANSVERS.SUPP.FOR FILTER P4S8
12	DW11702	DADO M8 INOX UNI5588 DIN934	S/S NUT M8 DIN934 (MIN. 20 PCS)
13	DW11600907	FILTRO VASCA POS. G12/03 & 11/03	TANK BACK FILTER
14	DW3003129	GOMITO PORTAGOMMA 12 - G3/8	ELBOW HOSE-CONNECTION 12 G3/8
15	DW3003130	GUARNIZIONE OR 123 NBR	O-RING 123 NBR
16	DW3009387	RONDELLA GOMITO CARICO	LOADING ELBOW WASHER
17	DW3003128	GOMITO DI CARICO G3/8	LOADING ELBOW G3/8
18	DW88110	PRESSOSTATO 250-40	PRESSURE SWITCH 250-40
19	DW3009363	SUPPORTO PRESSOSTATO	PRESSURE-SWITCH SUPPORT
20	DW500615	GHIERA CON INNESTO FILTRO MOD.50	FERRULE FOR FILTER CLUTCH
21	DW80208	GUARNIZIONE RAMPA LP2 DIAM.95X75X3	RISER GASKET D.95X75X3 (MIN. 2 PCS)
22	DW500603	POZZETTO SCARICO CON FILETTO	SCRAP TRAY
23	DW392062	MANICOTTO 1" 1/2 90° (TRAVASI 2008)"	PIPE COUPLING 90° 1"1/2
24	DW392061	MANICOTTO 1" 1/2 DRITTO (TRAVASI 2008)"	PIPE COUPLING 1"1/2
25	DW392060	GUARNIZIONE 65X47X3 NBR (TRAVASI 2008)	GASKET 65X47X3 NBR
26	DW392059	GHIERA 1" 1/2 (TRAVASI 2008)"	RING NUT 1" 1/2
27	DW3060212	MANICOTTO RADIO D42	PIPE COUPLING D.42

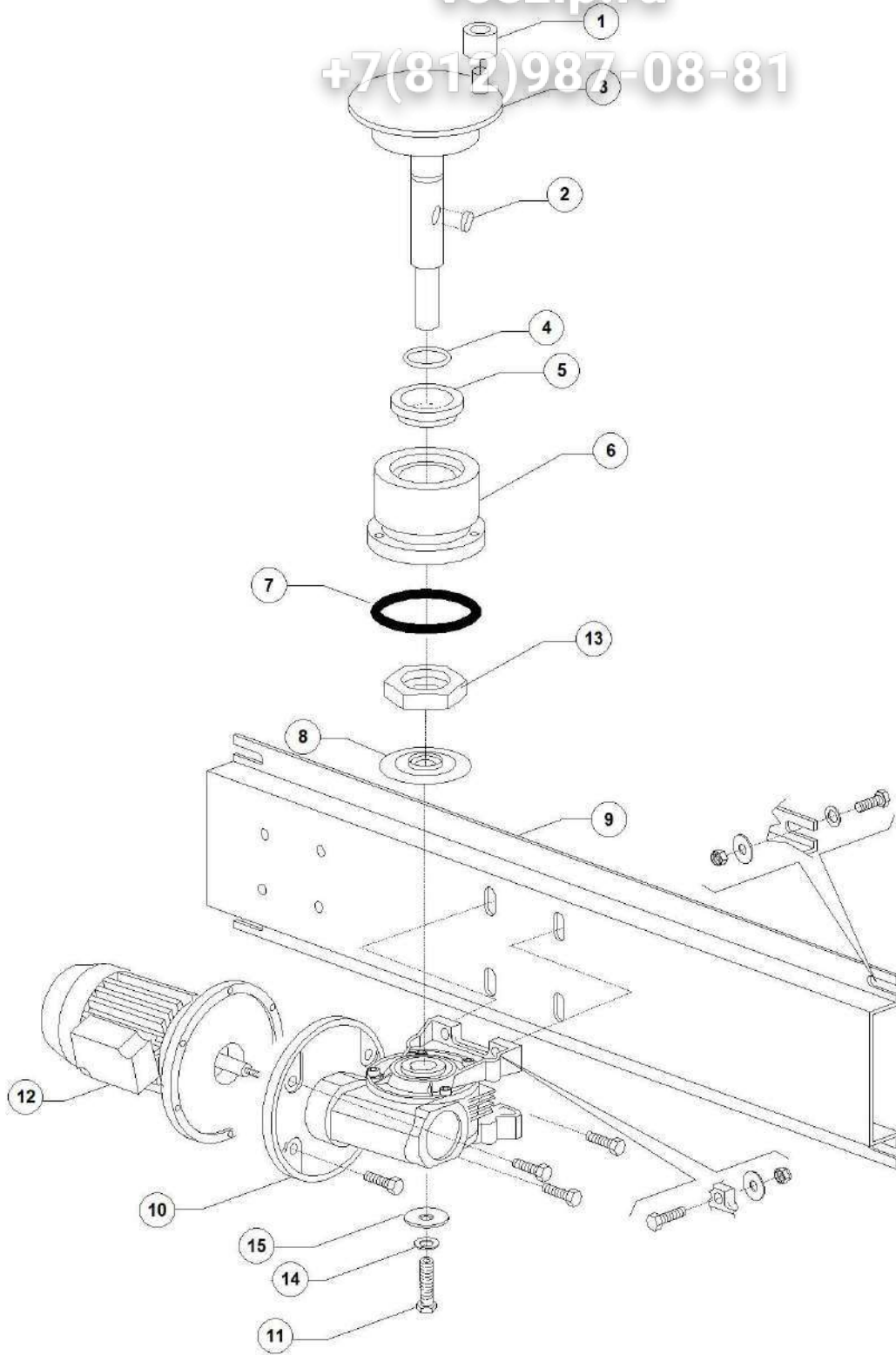

Pos.	Code	Descrizione	Description
1	DW3003012	RULLINO PER ECCENTRICO	ROLLER FOR ECCENTRIC
2	DW2001046	CHIAVETTA 8X7X30 INOX	S/S FLAT KEY 8X7X30
3	DW3003116	ASSIEME ALBERO LUNGO CON ECC. '99	ECCENTRIC SHAFT
4	DW13023	GUARNIZ. OR 131 (4093)	OR 131 (4093) NBR GASKET
5	DW13024	PARAOLIO DEM40 TC30X42X7 MOLLA INOX	OIL SPLASH GUARD DEM 40 TC 30X42X7
6	DW3004131	BOCCOLA ALBERO RIDUT. AX	ECCENTRIC SHAFT BUSH
7	DW13015	GUARNIZIONE 6225 OR 160 NBR	6225 O-RING 160 NBR (MIN. 5 PCS)
8	DW3004161	DISCO ANTIGOCCIA PER ASSE MOTORIDUT	PROTECTION DISK
9	DW391024	SUPPORTO MOTORID. TYPE 91-92	GEARMOTOR SUPPORT
10	DW3000210	RIDUT. TRAINO LIMIT. 1:80 DESTRO	R 1:80 REDUCTION GEAR CONVEYOR MACHINES
11	DW11165	VITE INOX M8X40 TE DIN933	M8X40 TE S/S SCREW
12	DW3020105/A	MOTORE 4/6P 230V3 50Hz	MOTOR 4/6P 230V3 50HZ
13	DW3004183	DADO PER BOCCOLA COD.3004131-32	FERRULE FASTENING NUT
14	DW11609	RONDELLA GROWER M8 INOX DIN127	M8 S/S GROWER WASHER DIN127
15	DW11186	RONDELLA 8X24 PIANA INOX DIN9021	8X24 S/S PLANE WASHER DIN902

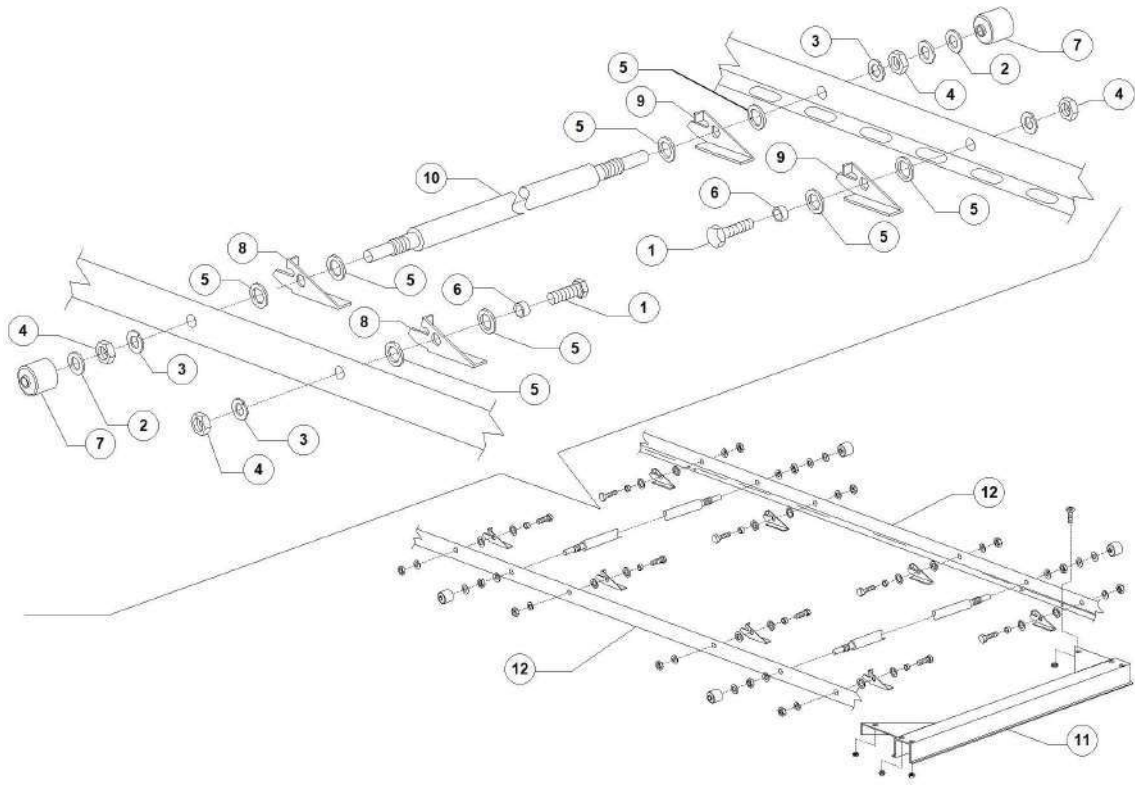



RX164EDX HR5 DR24 DDE 380-400V/3N/50 EAC - DW01020490 - Conveyor - DW201E

Pos.	Code	Descrizione	Description
1	DW11109	VITE INOX M10x20 TE DIN933	M10X20 TE S/S SCREW DIN933
2	DW11185	RONDELLA 8X16 PIANA INOX DIN125	8X16 S/S PLANE WASHER DIN125
3	DW11192	RONDELLA GROWER M10 INOX DIN 127B	M10 S/S GROWER WASHER DIN127B
4	DW11719	DADO M10 INOX DIN 934	S/S NUT M10 DIN934
5	DW3003024	RONDELLA CARRELLO 19X12X1 PTFE	WASHER 19X12X1 PTFE
6	DW3003025	BOCCOLA DIST. CARRELLO 11,7X10X6 IN	SPACER FOR CARRIAGE 11,7X10X6
7	DW3003026	BOCCOLA RULLINO DIST. CARRELLO DELR	SPACER FOR CARRIAGE
8	DW3003100	SALTARELLO INOX DX	RIGHT S/S PAWL
9	DW3003101	SALTARELLO INOX SX	LEFT S/S PAWL
10	DW3003010	ASSE TRAVERSO PER CARRELLO	CARRIAGE SPACING AXLE
11	DW391014	OMEGA GUIDA ECCENTRICO TYPE 91-92 (N)	GUIDE
12	DW392015	PIEG. TELAIO CARRELLO TYPE 92	MOBILE FRAME TYPE 92

+7(812)987-08-81

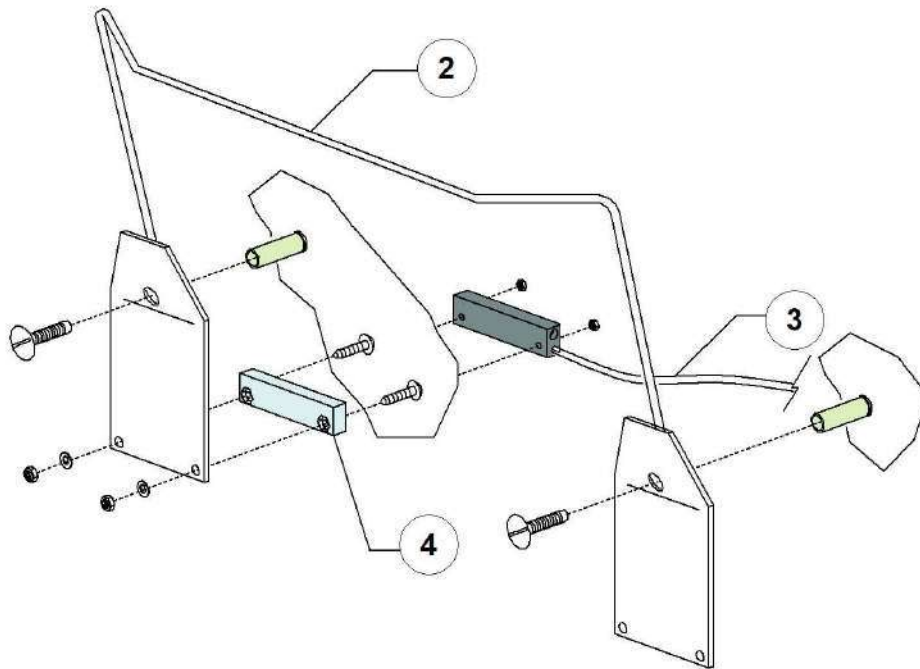
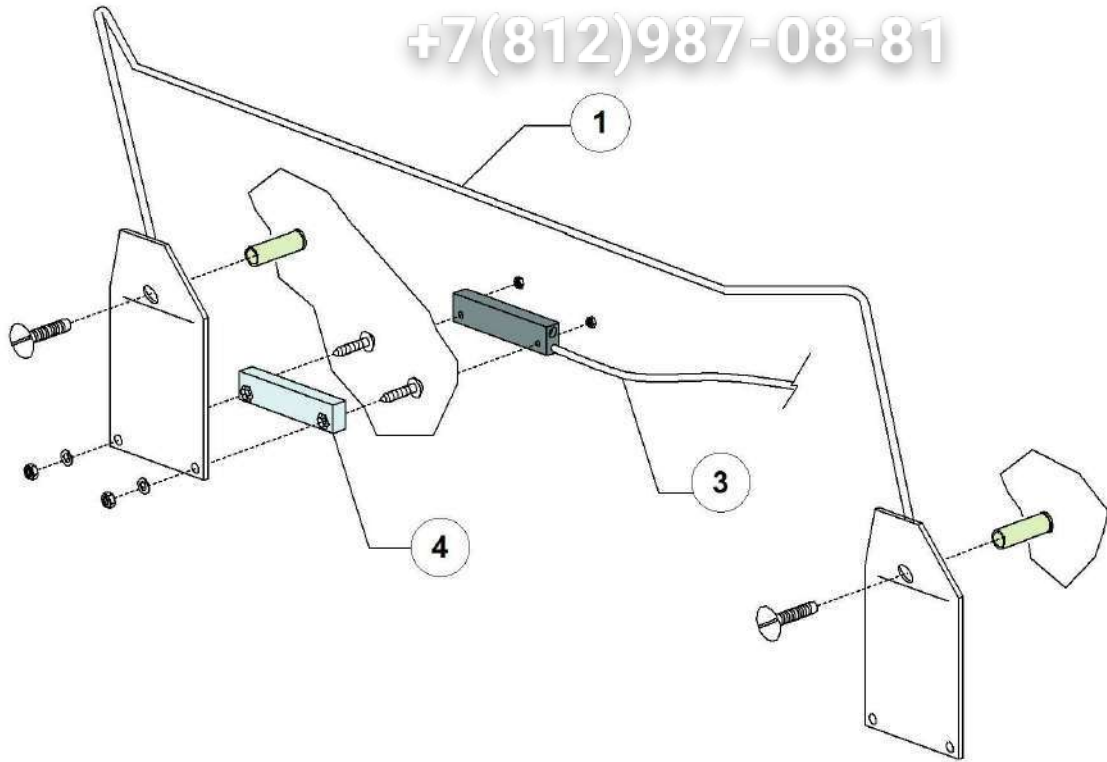

Pos.	Code	Descrizione	Description
1	DW391044	ECONOMIZZATORE LAVAGGIO TYPE 91	WASH ECONOMIZER TYPE 91
2	DW391047	ECONOMIZZATORE RISCIAQUO TYPE 91-92	RINSE ECONOMIZER TYPE 91/92
3	DW10778	MICROCONTATTO MAGNETICO REED	DOOR MICROSWITCH
4	DW391046	MAGNETE M303NCCANE32 ECON. TYPE 91-92	MAGNETIC UNIT

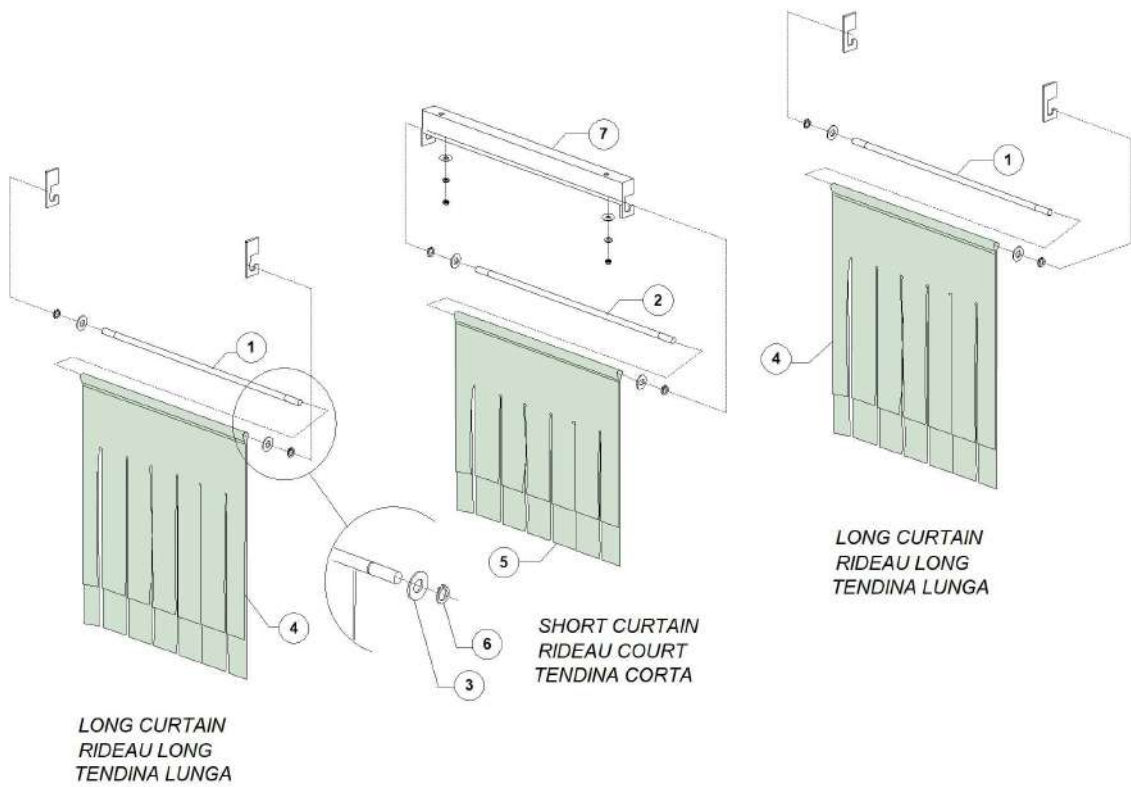

Pos.	Code	Descrizione	Description
1	DW3004052	ASTA SOSTEGNO PER TENDA INTERNA	INNER CURTAIN ROD
2	DW391038	ASTA SOST. PER TENDA INT. TYPE 91-92	INNER CURTAIN ROD
3	DW11185	RONDELLA 8X16 PIANA INOX DIN125	8X16 S/S PLANE WASHER DIN125
4	DW3071072	TENDINA INTERNA RX	INTERNAL CURTAIN
5	DW391037	TENDINA PAR. INTERNA CORTA TYPE 91-92	INNER SHORT CURTAIN TYPE 91-92
6	DW11815	SEEGER DIAM.8 INOX UNI7435	SNAP RING D.8 S/S
7	DW391036	#PIEG. SUPP. TENDINA DX/SX TYPE 91-92	

+7(812)987-08-81

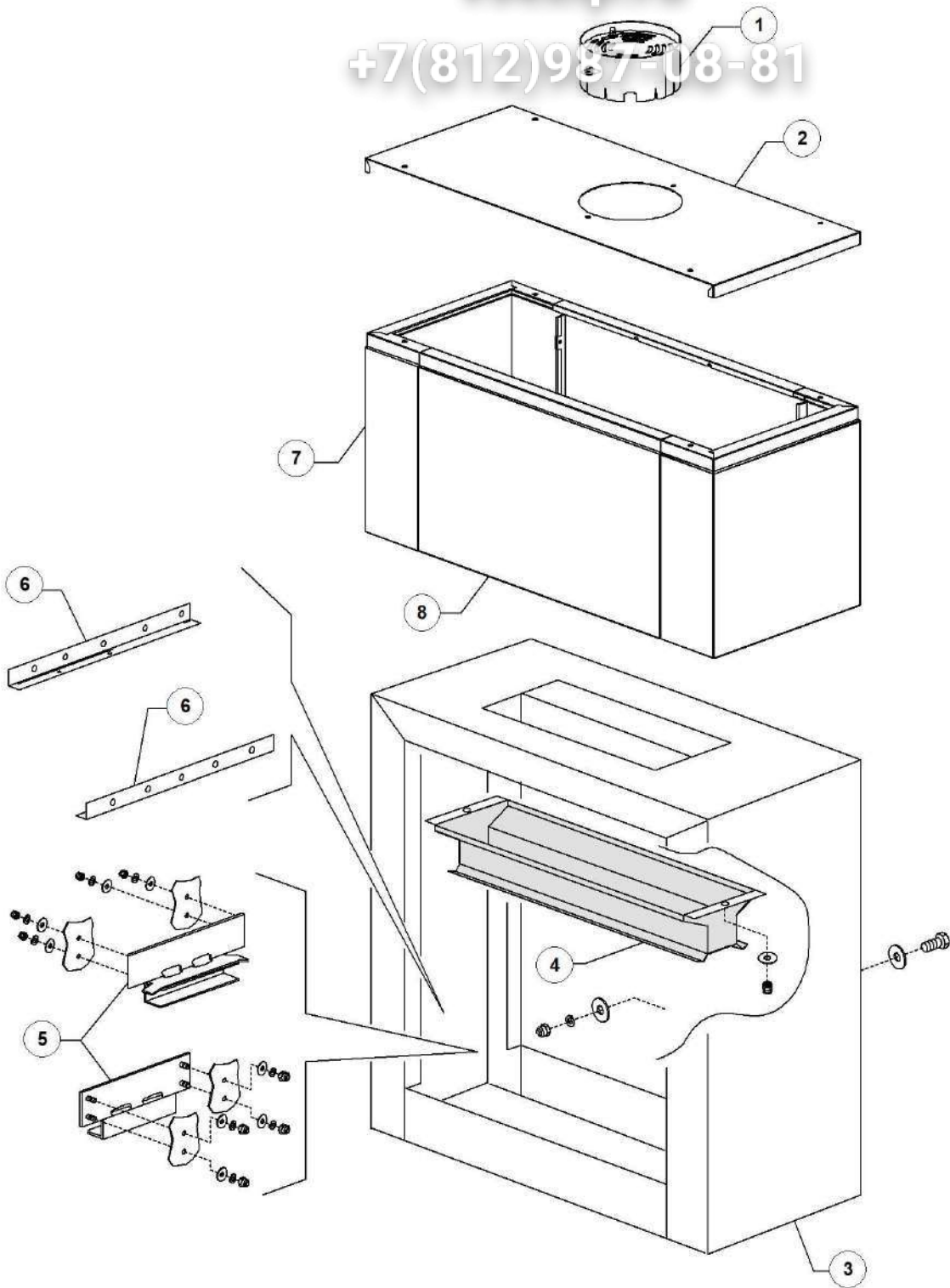

Pos.	Code	Descrizione	Description
1	DW3071115	AS CAMINO HR10 RX	CHIMNEY ASSEMBLY FOR HEAT RECOVERY
2	DW3070307	COPERCHIO RECUP LAVAVAS 2016/HR5	HEAT RECOVERY COVER
3	DW392030	ASSIEME PARASPRUZ CONDENSA VAPORI (N)	STEAM CONDENSER SPLASH GUARD
4	DW3009543	GRUPPO ASPIRAZIONE LC81	SUCTION ASSEMBLY
5	DW392029	ASS. GUIDACESTO PAR. CONDENSA VAPORI	STEAM CONDEN.SPLASH GUARD BASKET GUIDE
6	DW391058	TELAIO MOBILE ASCIUG. TYPE 91-92	MOBILE FRAME DRYER TYPE 91-92
6	DW391059	TELAIO MOBILE CONDENSA TYPE 91-92	MOBILE FRAME STEAM CONDENSER TYPE 91-92
7	DW3070305	CARTER HR5 LAVAVASSOI-COMPACT 2016	HEAT RECOVERY EXTERNAL FRAME
8	DW3070306	PIEG. PORTA REC LAVAVASSOI 2016-HR5	SIDE PANEL

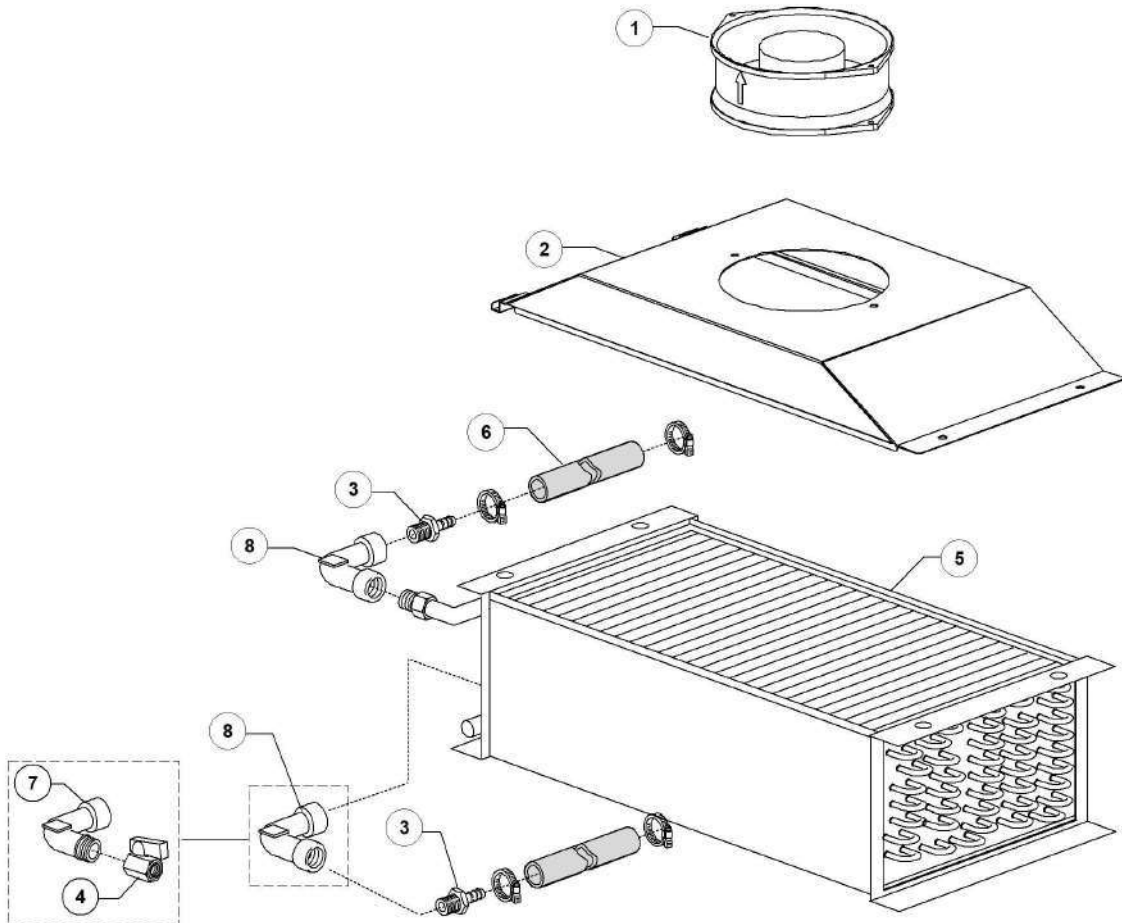



Pos.	Code	Descrizione	Description
1	DW11600715	MOTOVENTIL. 230 V/50-60 HZ HR/09	CENTRIFUGAL FAN 230V 50/60HZ
2	DW3070259	PIEG BASE SUPPORTO VENT HR10-HR5-SC10 RX	STEAM CONDEN./HEAT RECOVERY FAN SUPPORT
3	DW3071299	PORTAGOMMA M 1/2 DIAM 12 PG260 INOX	S/S HOSE CONNECTOR 10 M1/2 PG260
4	DW3002140	RUBINETTO FF 1/2	FF 1/2 WATER VALVE
5	DW3000155	BATTERIA TRAINO CONDENSA VAPORI LC	STEAM CONDENSER COIL
6	DW2907350	TUBO GOMMA EPDM 12X20	12X20 EPDM RUBBER PIPE
8	DW3071188	RACCORDO INOX GOMITO F/F 1/2"	S/S UNION ELBOW 1/2" F-F

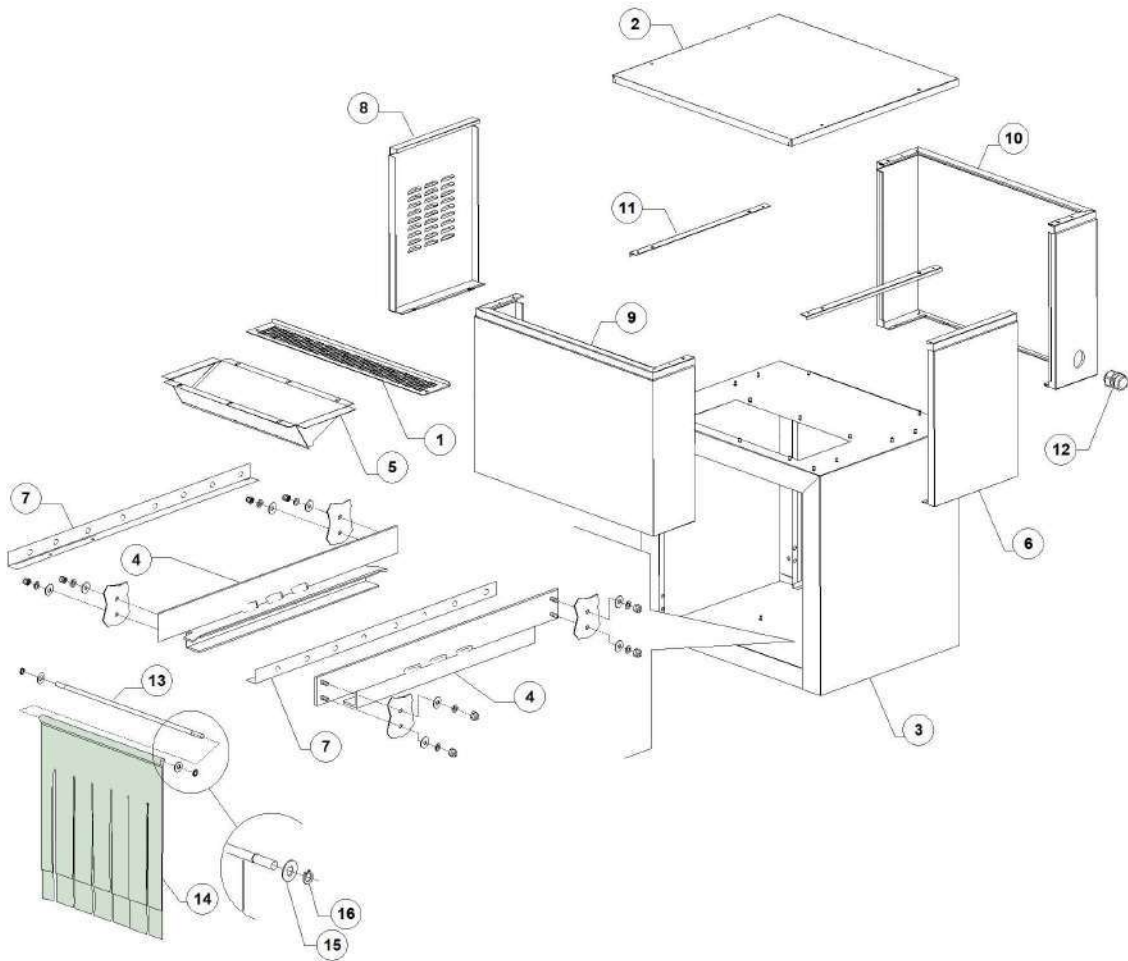

Pos.	Code	Descrizione	Description
1	DW392021	LAMIERA PROTEZIONE ASCIUGATURA	DRYER PROTECTION
2	DW391114	PIEG. COPERCHIO ASCIUGATURA/2016	DRYER COVER
3	DW391124	ASS. PARASPRUZZI ASCIUG. TRAINETTO/2016	DRYER SPLASH GUARD
4	DW392019	ASS. GUIDACESTO PAR. ASCIUGATURA	DRYER SPLASH GUARD BASKET GUIDE
5	DW391135	ASS. TRAMOGGIA ASCIUGATURA/2016	DRYER AIR CONVEYOR ASSEMBLY
6	DW391108	PIEG. PORTA ANT. ASCIUGATURA/2016	DRYER FRONT PANEL
7	DW391058	TELAIO MOBILE ASCIUG. TYPE 91-92	MOBILE FRAME DRYER TYPE 91-92
8	DW391110	PIEG. PORTA POST. ASCIUGATURA/2016	
9	DW391104	PIEG. CARTER ANT. ASCIUGATURA/2016	DRYER FRONT PANEL
10	DW391106	PIEG. CARTER POST. ASCIUGATURA/2016	DRYER BACK PANEL
11	DW3070179	PIEG. RINF PORTA ASCIUG RX OPTIMA	
12	DW80419	PRESSACAVO PG29 OBO	CABLE FITTING
13	DW391038	ASTA SOST. PER TENDA INT. TYPE 91-92	INNER CURTAIN ROD
14	DW391037	TENDINA PAR. INTERNA CORTA TYPE 91-92	INNER SHORT CURTAIN TYPE 91-92
15	DW11185	RONDELLA 8X16 PIANA INOX DIN125	8X16 S/S PLANE WASHER DIN125
16	DW11815	SEEGER DIAM.8 INOX UNI7435	SNAP RING D.8 S/S

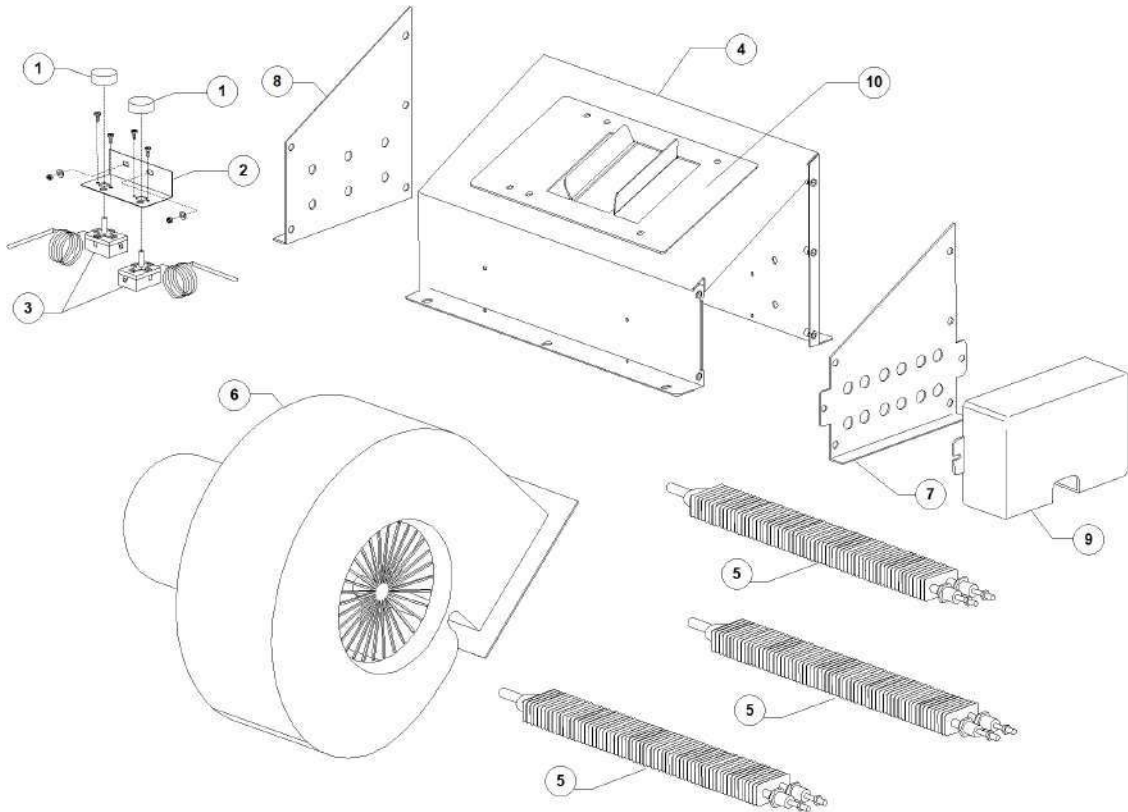

Pos.	Code	Descrizione	Description
1	DW15105/C	MANOPOLA TERMOSTATO 0-300°C	THERMOSTAT KNOB 0-300°C
2	DW3009104	PIEG. SQ. TERMOSTATI PER ASCIUGATUR (N)	DRYER THERMOSTATS SUPPORT
3	DW10707/3	TERMOSTATO TR2 0-280° C/ALB	THERMOSTAT
4	DW3070120/A	#PIEG. CARTER PER RESIST ASCIUG RX 2017	HEATING ELEMENTS HOLDER
5	DW3071075	RESISTENZA RETTANGOLARE 1,5 kW	1500W RECTANGULAR HEATING ELEM.
6	DW3003118	MOTOVENTILAT VMN604 0,25KW 230/400 50HZ	CENTRIFUGAL FAN 0,25KW 230/400V 50HZ
7	DW3070142/A	FRONTE CARTER PER RES RET RX 2017 (N)	FRONT BEND FOR HEATING ELEMENTS
8	DW3070177/A	POST CARTER PER RES RET RX 2017 (N)	REAR BEND FOR HEATING ELEMENTS
9	DW3071078	SCATOLA COPRIRRESISTENZE RX	HEATING ELEMENT COVER BOX

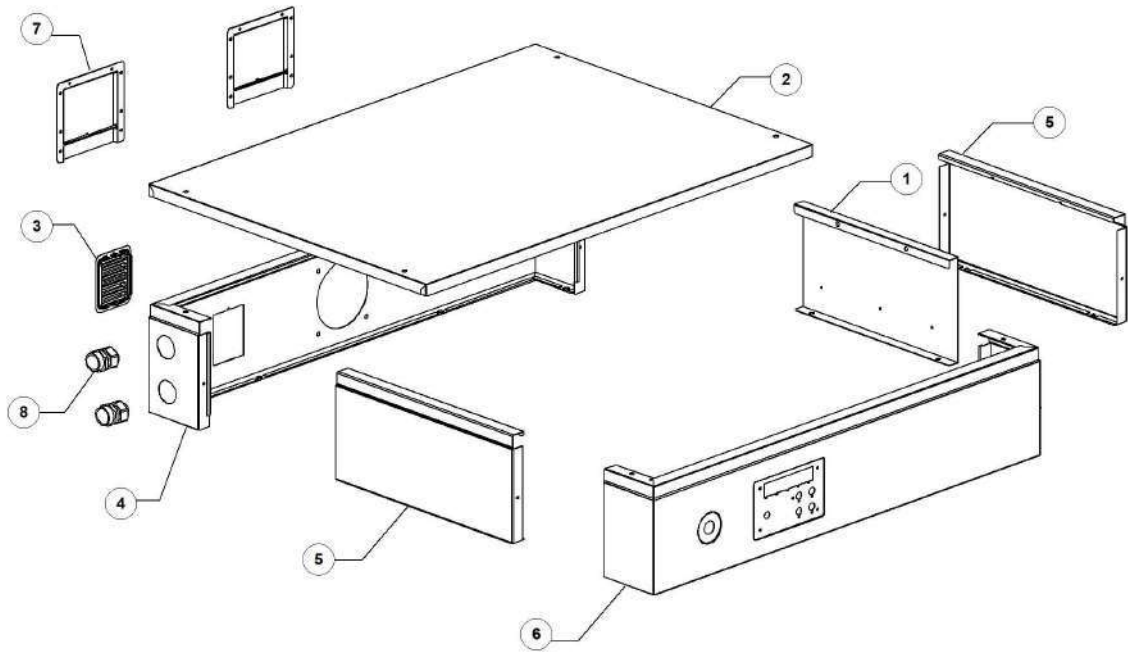

Pos.	Code	Descrizione	Description
1	DW391122	PIEG. PIASTRA SCHEDA J104 TRAINETTO/2016	MAINBOARD SUPPORT PLATE
2	DW3070242	COPERCHIO QUADRO 850 RX EVO-COMPACT	CONTROL BOARD COVER 850
3	DW25046	TAPPO CON GELOSIE	VENTILATION GRID
4	DW391118	PIEG. CARTER POST. QUADRO/2016	
5	DW391120	PIEG. PORTA QUADRO/2016	
6	DW391116/A	PIEG. CARTER ANT. QUADRO DIHR/2016	BOARD FRONT PANEL DIHR
7	DW3071286	CARTER PER IPX4 /IPX5 ESTERNO	EXTERNAL PROTECTION IPX4/IPX5
8	DW80419	PRESSACAPO PG29 OBO	CABLE FITTING

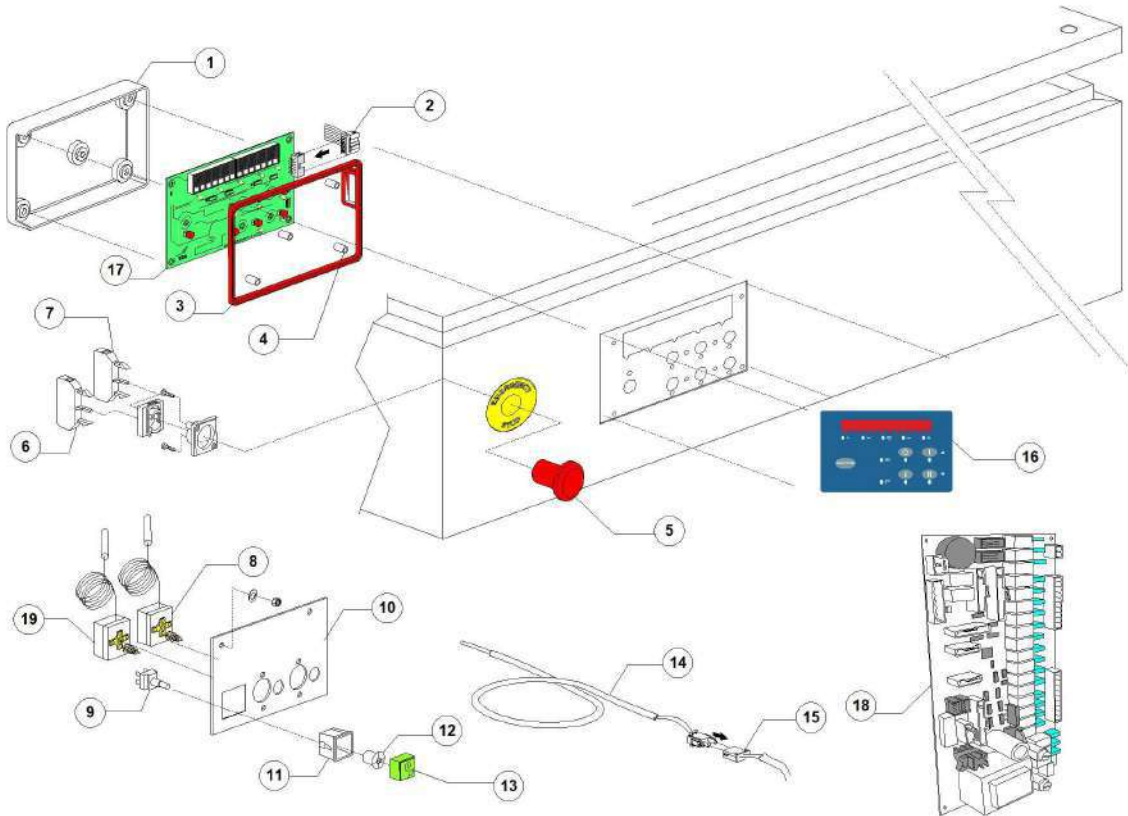



Pos.	Code	Descrizione	Description
1	DW11600931/A	SCAT.PROT. SCHEDA 11600931 (145X69X19)	ELECTRONIC BOARD PROTECTION BOX 11600931
2	DW50651	PIATTINA MULTIFILO F16P L1000"	RIBBON CABLE F16p L1000"
3	DW11600931/B	GUARNIZIONE PER SCATOLA 11600931/A	PROTECTION BOX GASKET DW11600931/A
4	DW50561	DIST. SCHEDE ELETTR. 2009 D.8X10	MAINBOARD SPACER D.8X10
5	DW3002050	PULS.FUNGO D.35 OP.SBLOC.ROT. 30A3	EMERGENCY BUTTON
6	DW3002056	CONTATTO 1NC RET. 31A5	CONTACT 1NC
7	DW3002054	CONTATTO 1NA	CONTACT 1NA
8	DW2000430	TERMOSTATO DI SICUR. 110 1500PVC	SAFETY THERMOSTAT
9	DW15812	FRUTTO INTERRUTTORE 16A	16A SWITCH
10	DW391010	STAFFA PORTA TERMOSTATI TYPE 91-92	THERMOSTAT SUPPORT
11	DW15815	SUPPORTO QUADRO SQ1 SINGOLO GRIGIO	SQUARE GREY SINGLE SUPPORT SQ1
12	DW15824	CAMMA VERDE-ARANCIO	GREEN-ORANGE CAM ROLL
13	DW15874	TASTO Q6 VERDE SERIG.ON-OFF	GREEN ON/OFF KEY Q6
14	DW3006165	SONDA TERMOSTATO SCHEDA TUNNEL	THERMOSTAT PROBE
15	DW3006170	PROLUNGA SONDA TERM. SCHEDA TUNNEL	THERMOSTAT PROBE EXTENSION
16	DW391090	MOSTRINA DIHR TYPE 91-92 / TYPE85 (UX)	CONTROL OVERLAY DIHR
17	DW11600931	TASTIERA SCORREVOLE 2009	SOFT TOUCH CONTROL PANEL 2009
18	DW3072148	SCHEDA MADRE RX EVO (BL)	MAINBOARD (BL)
19	DW3072158	TERMOSTATO DI SICUR. 90 1500PVC	SAFETY THERMOSTAT

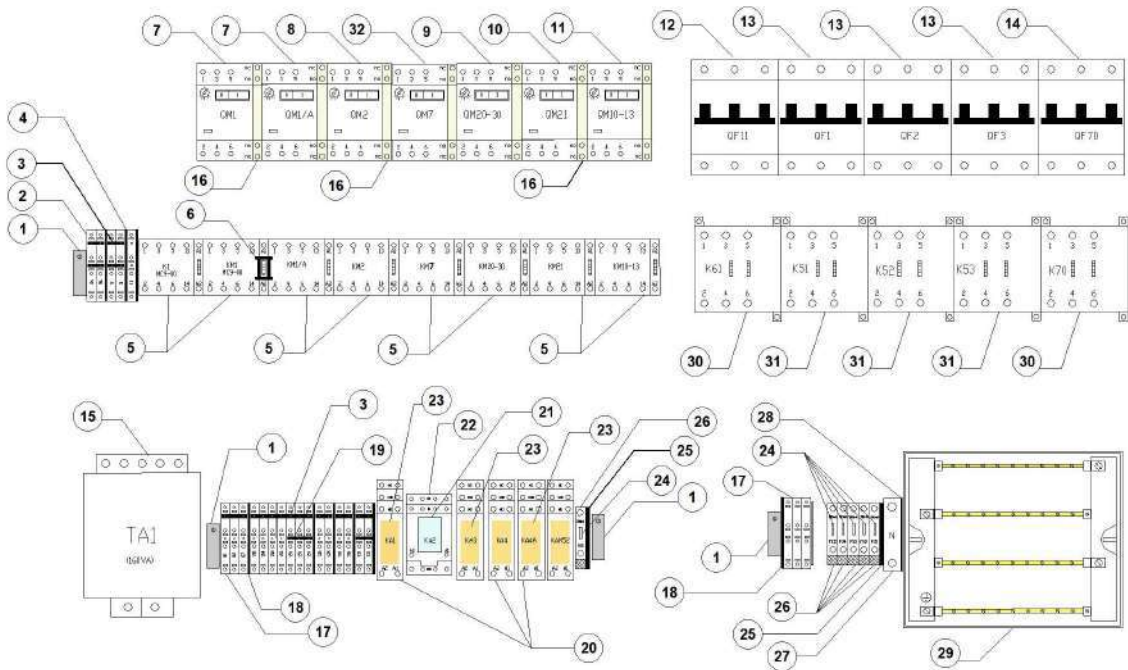

Pos.	Code	Descrizione	Description
1	DW3006093	FERMO PER GUIDA DIN	DIN RAIL RETAINER
2	DW3071122	MORSETTO 2.5mm DOPPIO A MOLLA (ZDK 2.5)	TERMINAL 2,5mmq DOUBLE
3	DW3071124	PONTE DI COLLEGAMENTO PER MORS. A (ZQV)	JUMPER FOR TERMINAL BOARD
4	DW3071123	PIASTRINA TERMINALE PER MORSETTO (ZAP/TW)	TERMINAL STOP PLATE
5	DW2000370	TELERUTTORE 9A/16A 24V 50/60Hz	CONTACTOR 9A/16A 24V 50/60Hz
7	DW2000389	INT.SALVAMOTORE MAGNETOTERM.0,63-1A	CIRCUIT BREAKER 0,63-1A
8	DW2000394	INT.SALVAMOTORE MAGNETOTERM.2,5-4A	CIRCUIT BREAKER 2,5-4A
9	DW2000389	INT.SALVAMOTORE MAGNETOTERM.0,63-1A	CIRCUIT BREAKER 0,63-1A
10	DW2000389	INT.SALVAMOTORE MAGNETOTERM.0,63-1A	CIRCUIT BREAKER 0,63-1A
10	DW2000393	INT.SALVAMOTORE MAGNETOT.1,6-2,5A	CIRCUIT BREAKER 1,6-2,5A
11	DW2000393	INT.SALVAMOTORE MAGNETOT.1,6-2,5A	CIRCUIT BREAKER 1,6-2,5A
12	DW2000403	INT. MAGNETOTERMICO TRIPOLARE 20A	THREE-POLE CIRCUIT BREAKER 20A
12	DW2000404	INT. MAGNETOTERMICO TRIPOLARE 25A	THREE-POLE CIRCUIT BREAKER 25A
13	DW2000404	INT. MAGNETOTERMICO TRIPOLARE 25A	THREE-POLE CIRCUIT BREAKER 25A
14	DW2000412	INT. MAGNETOTERM. TRIPOLARE 10A (672297)	THREE-POLE CIRCUIT BREAKER 10A
15	DW3006060	TRASF.160VA 0-230-400-415-440/0-24V	TRANSFORMER160VA 0-230-400-415-440/0-24V
16	DW3006080	CONTATTO AUX. LMS25 11LMH11 1NA+1NC	AUXILIARY CONTACT 1NA-1NC
17	DW3071122	MORSETTO 2.5mm DOPPIO A MOLLA (ZDK 2.5)	TERMINAL 2,5mmq DOUBLE
18	DW3071123	PIASTRINA TERMINALE PER MORSETTO (ZAP/TW)	TERMINAL STOP PLATE
19	DW3071124	PONTE DI COLLEGAMENTO PER MORS. A (ZQV)	JUMPER FOR TERMINAL BOARD
20	DW3006079	ZOCCOLO X RELE'MODUL.2C/24V	BASE FOR RELAY
21	DW3071140	RELE' MODUL. 4C/DEV. 24V 7A	MODULAR RELAY 4C/DEV. 24V 7A
22	DW3071141	ZOCCOLO X RELE'MODUL.4C/24V 10A	BASE FOR RELAY
23	DW3006078	RELE' MODUL. 2C/DEV. 24V	MODULAR RELAY 2C/DEV. 24V
24	DW15163	FUSIBILE 5X20 1A	5X20 1A FUSE
24	DW15174	FUSIBILE 5X20 6.3A RITARDATO	5X20 6.3A DELAYED FUSE
25	DW3006144	PIASTRINA CHIUSURA X STK1	TERMINAL STK1 END PLATE
26	DW3006147	MORSETTO PORTAFUSIBILI 5x20 (5x25)	FUSE CARRIER
27	DW3006156	MORSETTO NEUTRO 35mmq BLU	TERMINAL 35mmq BLEU
28	DW3006084	PIASTRINA CHIUSURA X MORSETTI RK35	TERMINAL RK35 END PLATE
29	DW3071168	MORSETTIERA RX 44X80X137 125A	TERMINAL BOARD 44X80X137 125A
30	DW2000385	TELERUTTORE 36A/20A 24V 50/60Hz	CONTACTOR 36A/20A 24V 50/60Hz
31	DW2000385	TELERUTTORE 36A/20A 24V 50/60Hz	CONTACTOR 36A/20A 24V 50/60Hz
32	DW2000393	INT.SALVAMOTORE MAGNETOT.1,6-2,5A	CIRCUIT BREAKER 1,6-2,5A

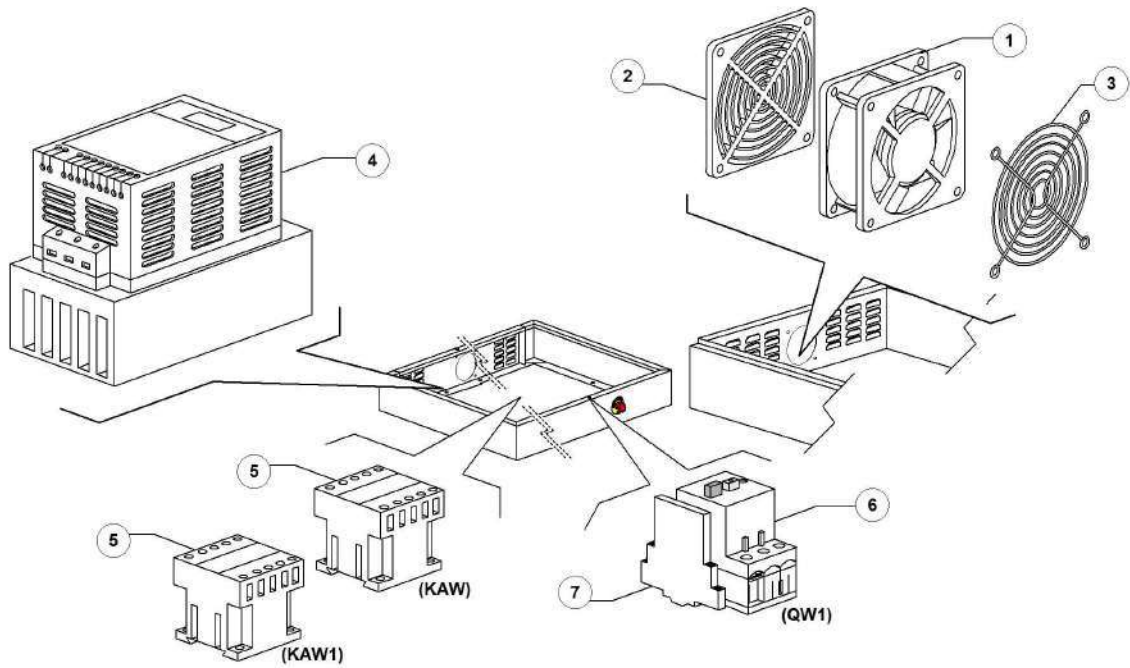

RX164EDX HR5 DR24 DDE 380-400V/3N/50 EAC - DW01020490 - Speed adjuster - DW201E

Pos.	Code	Descrizione	Description
1	DW3000118	VENTOLA 120X38 220VAC PER INVERTER	INVERTER COOLING FAN 120X38 220VAC
2	DW3000118/A	FILTRO PLAST INVERTER 120X120	INVERTER PLASTIC FILTER 120X120
3	DW3000118/B	GRIGLIA PROTEZ.INVERTER 120MM	PROTECTION GRID
4	DW3000117	INVERTER MONOFASE 240V 0,55 KW	INVERTER 240V 0,55KW
5	DW2000370	TELERUTTORE 9A/16A 24V 50/60Hz	CONTACTOR 9A/16A 24V 50/60Hz
6	DW2000393	INT.SALVAMOTORE MAGNETOT.1,6-2,5A	CIRCUIT BREAKER 1,6-2,5A
7	DW3006080	CONTATTO AUX. LMS25 11LMH11 1NA+1NC	AUXILIARY CONTACT 1NA-1NC

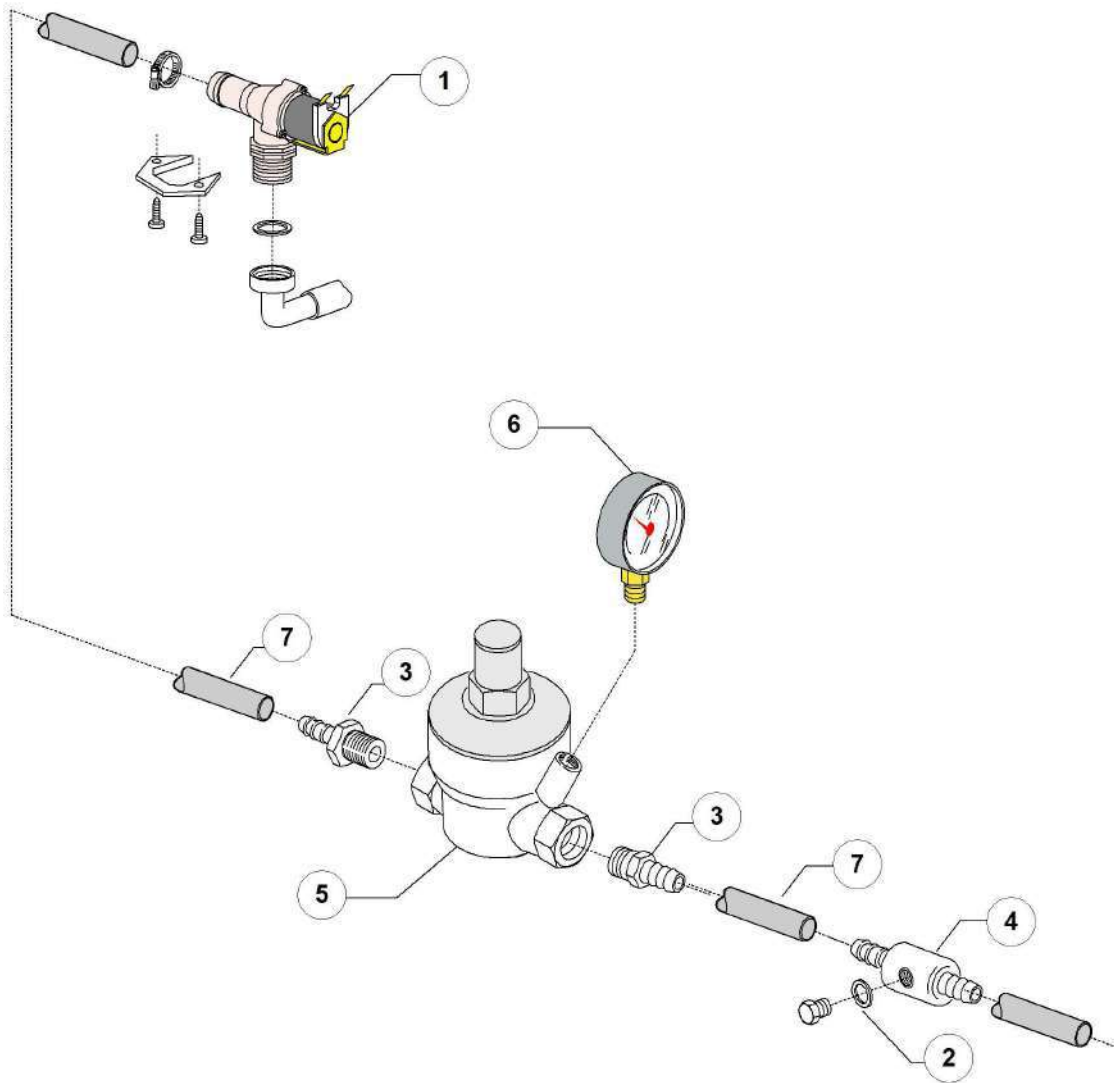

Pos.	Code	Descrizione	Description
1	DW2000093	ELETTROV. 3/4" - D.14 90° 24V SINGOLA	SINGLE SOLENOID VALVE 3/4" D.14 24V 90°
2	DW13309	GUARNIZIONE DIAM.10x14x1,5	GASKET D.10X14X1,5
3	DW3071299	PORTAGOMMA M 1/2 DIAM 12 PG260 INOX	S/S HOSE CONNECTOR 10 M1/2 PG260
4	DW3003906	#DERIV. A T ENTR. BRILL. CON TAPPO 1/8	T-PIECE W/PLUG 1/8"
5	DW391025	RIDUT. DI PRESS. 533441 CALEFFI	PRESSURE REDUCER
6	DW2000244	MANOMETRO RIDUTTORE PRESS.1/4CONIC	PRESSURE REDUCTION GAUGE 1/4"
7	DW2907350	TUBO GOMMA EPDM 12X20	12X20 EPDM RUBBER PIPE

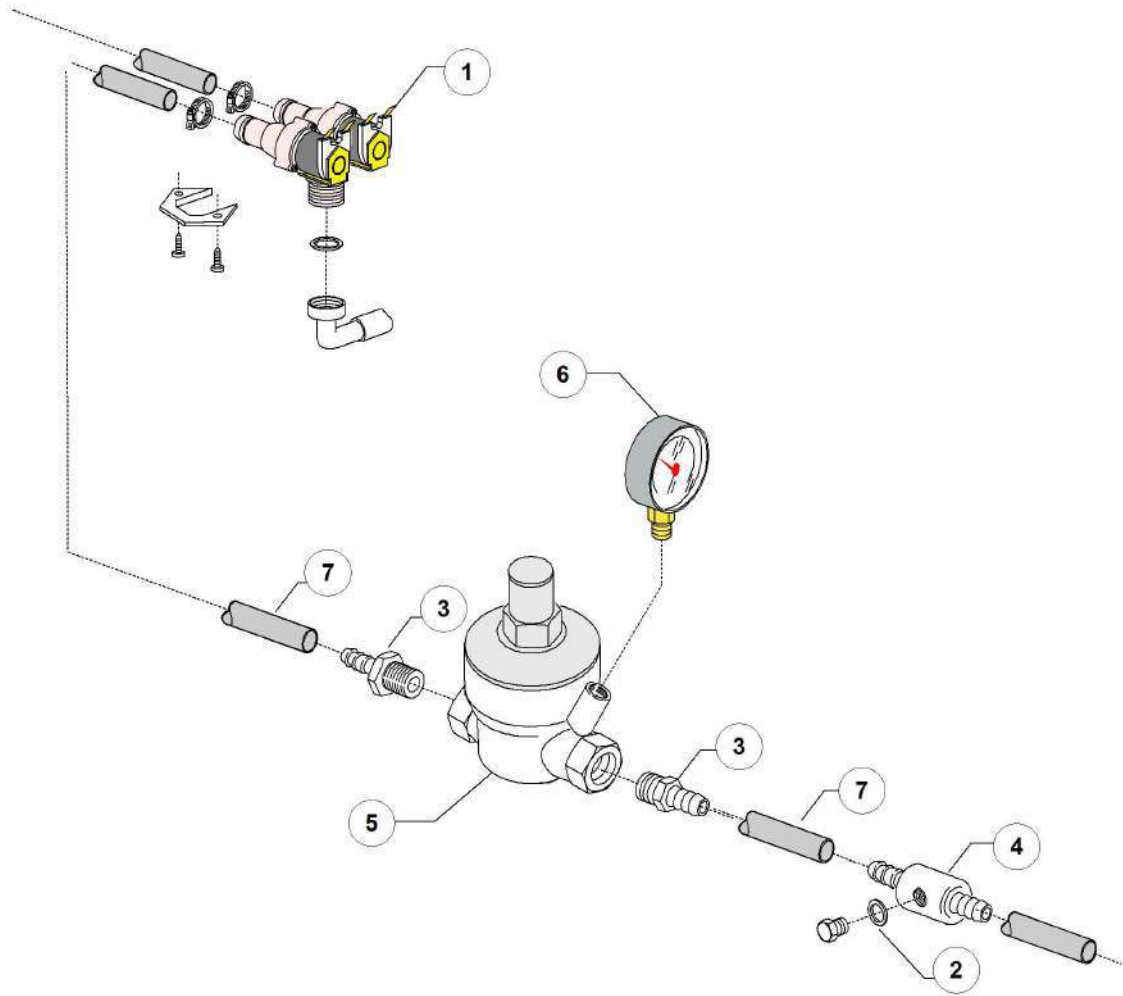



Pos.	Code	Descrizione	Description
1	DW2000094	ELETTROV. 3/4" - D.14 90° 24V DOPPIA	DOUBLE SOLENOID VALVE 3/4" D.14 24V 90°
2	DW13309	GUARNIZIONE DIAM.10x14x1,5	GASKET D.10X14X1,5
3	DW3071299	PORTAGOMMA M 1/2 DIAM 12 PG260 INOX	S/S HOSE CONNECTOR 10 M1/2 PG260
4	DW3003906	#DERIV. A T ENTR. BRILL. CON TAPPO 1/8	T-PIECE W/PLUG 1/8"
5	DW391025	RIDUT. DI PRESS. 533441 CALEFFI	PRESSURE REDUCER
6	DW2000244	MANOMETRO RIDUTTORE PRESS.1/4CONIC	PRESSURE REDUCTION GAUGE 1/4"
7	DW2907350	TUBO GOMMA EPDM 12X20	12X20 EPDM RUBBER PIPE

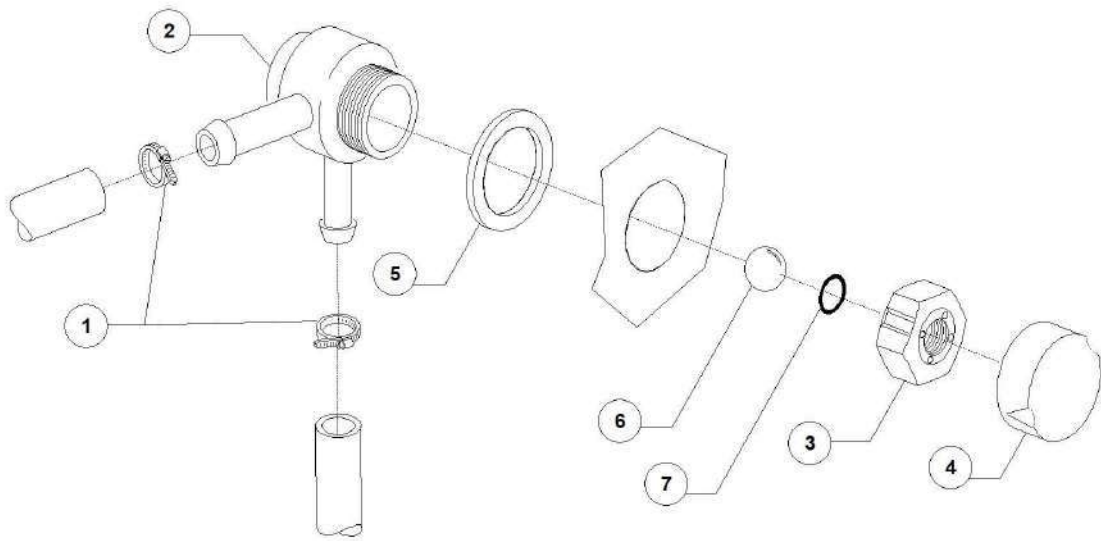

Pos.	Code	Descrizione	Description
1	DW11807	FASCETTE AISI 430 12/22	CLAMP 12/22 AISI 430 (MIN. 3 PCS)
2	DW15280	CORPO CENTRALE VALVOLA DVGW 07	DRAIN VALVE CENTER BODY
3	DW15281	DADO VALVOLA DVGW 07	VALVE NUT
4	DW15282	COPRI DADO VALVOLA DVGW 07	VALVE NUT COVER
5	DW15283	GUARNIZIONE VALVOLA DVGW 07	VALVE GASKET
6	DW15284	SFERA 5/8" VALVOLA DVGW 07"	5/8" BALL FOR DVGW VALVE 07
7	DW15285	GUARNIZIONE OR 115 KTW VALVOLA DVGW 07	O-RING 115 KTW

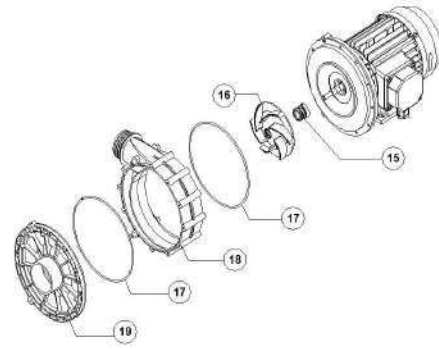
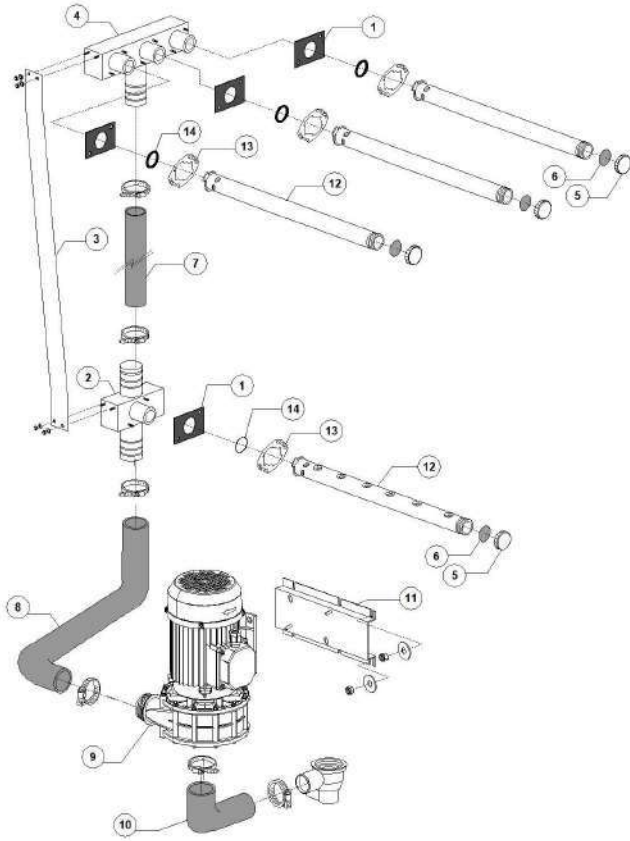

Pos.	Code	Descrizione	Description
1	DW391029	GUARNIZIONE DISTRIBUTORE TYPE 91-92	SPRAY ARMS RACK/RISER GASKET
2	DW392008	GRUPPO LAVAGGIO INF 1BRACCIO TYPE 92	1 ARM LOWER WASH ASSEMBLY
3	DW391042	PIATTO RINF. DISTRIB. LAV. TYPE 91-92	WATER FLOW BACK REINFORCEMENT
4	DW391027	GRUPPO LAVAGGIO SUP 3BRACCI TYPE 91-92	3 ARMS UPPER WASH ASSEMBLY
5	DW80304	TAPPO PER UGELLO TERMINALE GRIGIO	GREY WASH ARM PLUG
6	DW80305	GUARNIZIONE PER TAPPO TUBO GIRANTE	ARM PLUG GASKET
7	DW3060212	MANICOTTO RADIO D42	PIPE COUPLING D.42
8	DW392007	MANICOTTO MANDATA PREL. TYPE 92 DX	PREWASH RIGHT PIPE COUPLING
9	DW3000082	POMPA HP1.2 2241 220/380/50	PUMP HP1.2 220/380V3/50HZ
10	DW11600100	MANICOTTO ASPIRAZIONE G12/03	SUCTION PIPE COUPLING
11	DW11600623	STAFFA SUPPORTO POMPA G12	PUMP SUPPORT G12
12	DW391031	BRACCIO LAVAGGIO TYPE 91-92	WASH ARM TYPE 91/92
13	DW3060182	CAMMA AGGANCIO BAIONETTA NASTRO	ARM CONNECTION FLANGE
14	DW392050	GUA.OR 3X31 NBR 70SH RIF. 0310	O RING 3X31 NBR 70SH RIF. 0310
15	DW15080/C	PREMISTOPPA+CONTROF.POMPA F HP075"	ROTATING SEALS
16	DW3000082/D	#GIRANTE D.108 DW3000082 (PLA_092)	PUMP ROTOR
17	DW88231	GUARNIZIONE OR150	OR GASKET
18	DW3000082/B	#CHIOCCIOLA POMPA MEC71 (PLA_031)	THIS PART IS NO LONGER AVAILABLE
19	DW3000082/A	#FLAN. CHIOCCIOLA POMPA MEC71 (PLA_033)	THIS PART IS NO LONGER AVAILABLE

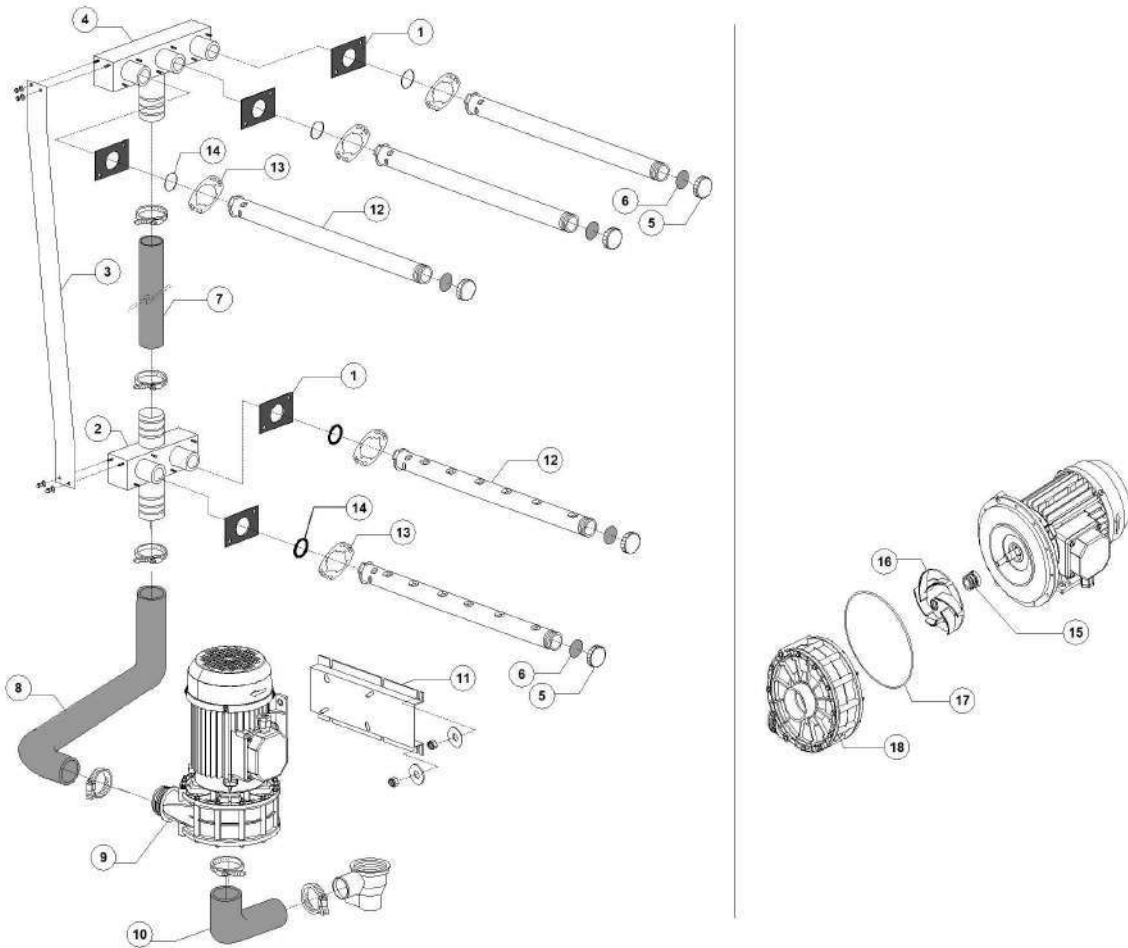

Pos.	Code	Descrizione	Description
1	DW391029	GUARNIZIONE DISTRIBUTORE TYPE 91-92	SPRAY ARMS RACK/RISER GASKET
2	DW391028	GRUPPO LAVAGGIO INF 2BRACCI TYPE 91-92	2 ARMS LOWER WASH ASSEMBLY
3	DW391042	PIATTO RINF. DISTRIB. LAV. TYPE 91-92	WATER FLOW BACK REINFORCEMENT
4	DW391027	GRUPPO LAVAGGIO SUP 3BRACCI TYPE 91-92	3 ARMS UPPER WASH ASSEMBLY
5	DW80304	TAPPO PER UGELLO TERMINALE GRIGIO	GREY WASH ARM PLUG
6	DW80305	GUARNIZIONE PER TAPPO TUBO GIRANTE	ARM PLUG GASKET
7	DW3060212	MANICOTTO RADIO D42	PIPE COUPLING D.42
9	DW22037	POMPA HP2.0 220-240/380-415 50Hz	PUMP HP2.0 220-240/380-415V3/50HZ
10	DW11600100	MANICOTTO ASPIRAZIONE G12/03	SUCTION PIPE COUPLING
11	DW11600623	STAFFA SUPPORTO POMPA G12	PUMP SUPPORT G12
12	DW391031	BRACCIO LAVAGGIO TYPE 91-92	WASH ARM TYPE 91/92
13	DW3060182	CAMMA AGGANCIO BAIONETTA NASTRO	ARM CONNECTION FLANGE
14	DW392050	GUA.OR 3X31 NBR 70SH RIF. 0310	O RING 3X31 NBR 70SH RIF. 0310
15	DW15080	PREMISTOPA+CONTROFACCIA	ROTATING SEALS
16	DW22045/O	#GIRANTE POMPA 2HP MEC80.T200SX(OLYMPIA)	PUMP ROTOR (PUMP 2HP)
17	DW10200290/O	GUARN.OR POMPA MEC80.T200SX(OLYMPIA)	OR 1225 GASKET
18	DW10200222/O	#KIT CHIOCCIOLA POMPA MEC80.T200SX(OLYMP)	SCROLL

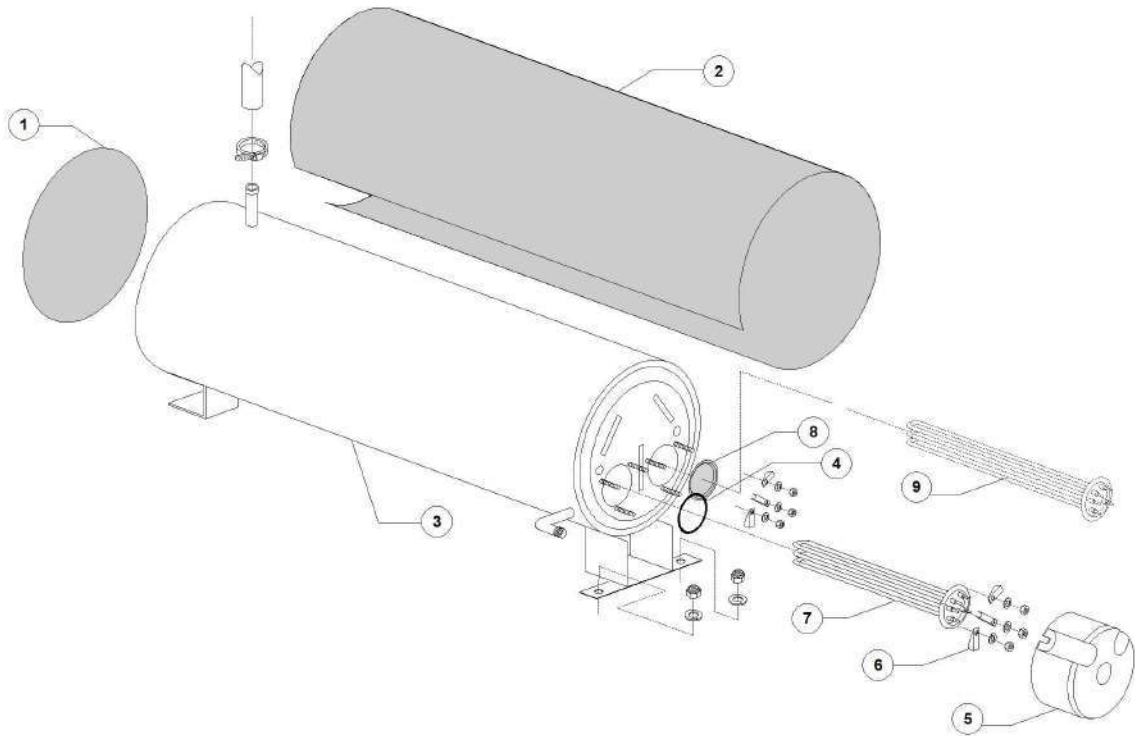



Pos.	Code	Descrizione	Description
2	DW3071291	COIBENTAZIONE BOILER D.155X500 TPA NASTR	BOILER INSULATING D.155X500
3	DW392004	BOILER 2 RES TYPE 92 (AISI 304)	BOILER
4	DW13015	GUARNIZIONE 6225 OR 160 NBR	6225 O-RING 160 NBR (MIN. 5 PCS)
5	DW75311	CUFFIOTTO PER RESISTENZA 26/03/97	HEATING ELEMENT COVER
6	DW16045	STAFFE FISSAGGIO RESIST.FORO 6.3	HEATING ELEMENT MOUNTING BRACKET D.6,3
7	DW30001011	RESIST.9000/9800W 230/240V 3	9000/9800W 230/240V 3 HEATING ELEM.
7	DW30001011/A	RESIST.12000/13070W 230/240V 3	12000/13070W 230/240V 3 HEATING ELEM.
9	DW30001011	RESIST.9000/9800W 230/240V 3	9000/9800W 230/240V 3 HEATING ELEM.
9	DW30001011/A	RESIST.12000/13070W 230/240V 3	12000/13070W 230/240V 3 HEATING ELEM.

+7(812)987-08-81

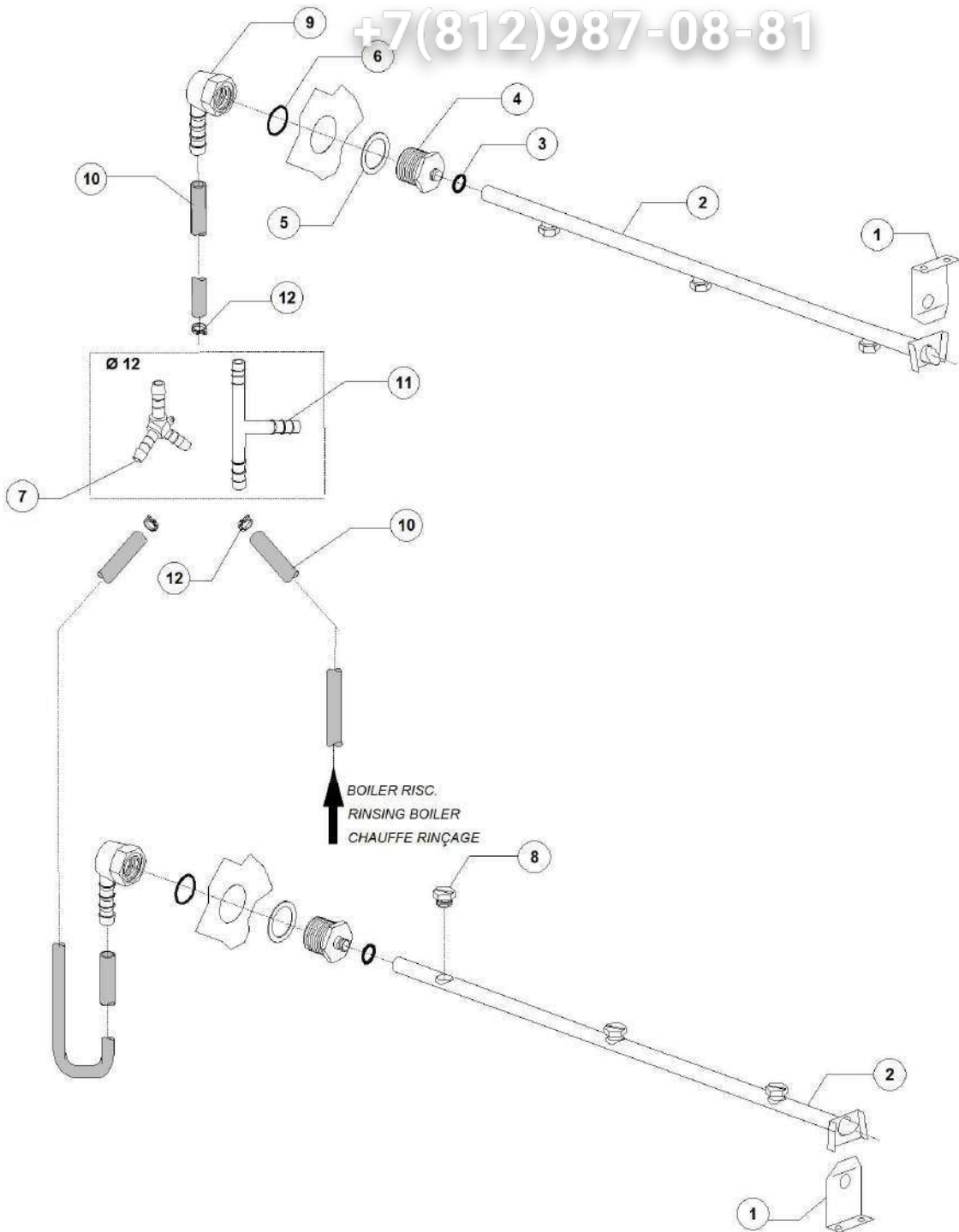

Pos.	Code	Descrizione	Description
1	DW3003905	STAFFA SUPPORTO BRACCIO RISC.TRAINETTO	RINSE ARM SUPPORT
2	DW391033	BRACCIO RISCIAQUO TYPE 91-92	RINSE ARM TYPE 91/92
3	DW391032	GUARNIZIONE OR RIF. 108 NBR D21.78 F12	O-RING NBR D.21.78 F12
4	DW3003127	INNESTO G3/8-DIAM.12 BRACCI RISCIAQUO	COUPLING G 3/8" D.12
5	DW3009387	RONDELLA GOMITO CARICO	LOADING ELBOW WASHER
6	DW3003130	GUARNIZIONE OR 123 NBR	O-RING 123 NBR
8	DW391034	UGELLO INOX RISCIAQUO 0,7 L/M 90°	STAINLESS STEEL RINSE NOZZLE
9	DW3003129	GOMITO PORTAGOMMA 12 - G3/8	ELBOW HOSE-CONNECTION 12 G3/8
10	DW2907350	TUBO GOMMA EPDM 12X20	12X20 EPDM RUBBER PIPE
11	DW391173	RACCORDO A T D12 INOX	S/S UNION TEE D.12
12	DW11807	FASCETTE AISI 430 12/22	CLAMP 12/22 AISI 430 (MIN. 3 PCS)

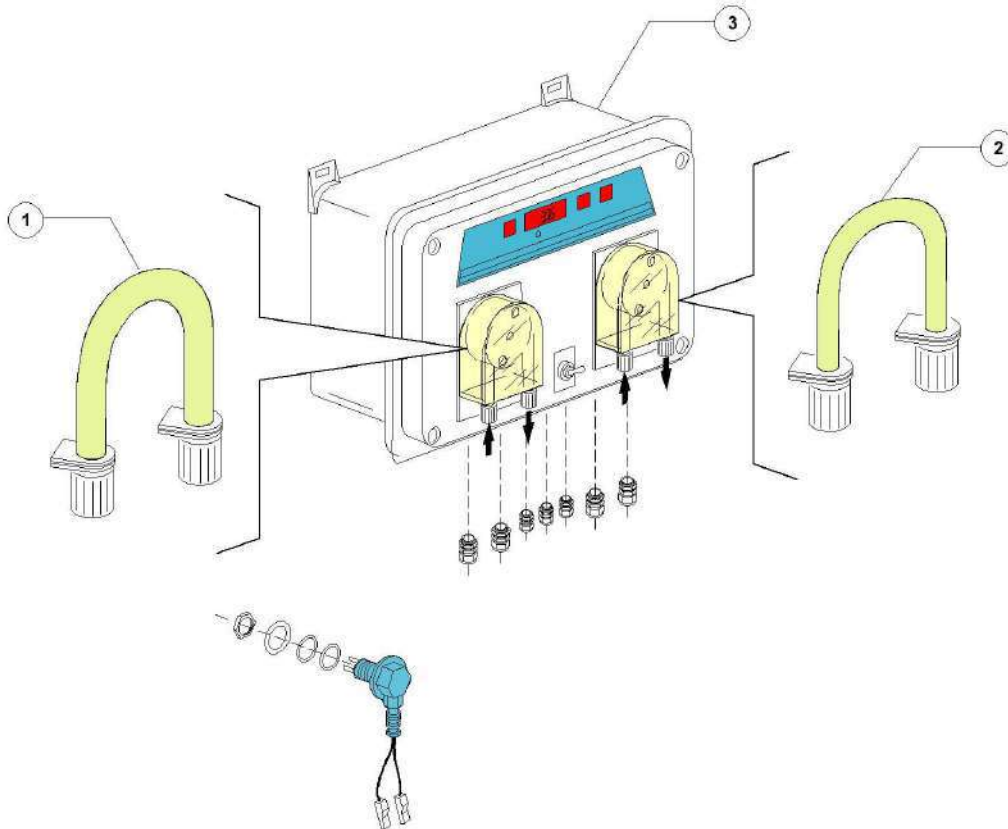

Pos.	Code	Descrizione	Description
1	DW15185	TUBO MEMBRANA DDE SEKO DET.	SEKO DISPENSER THERMOPLASTIC HOSE
2	DW15186	TUBO MEMBRANA SILICONE DDE BRILL.	SEKO DISPENSER THERMOPLASTIC HOSE
3	DW15181/A	CENTRALINA 06 DOSAT.BRILL./DETERG. 24V	RINSE AID AND DETERGENT DOSING PUMPS BOX

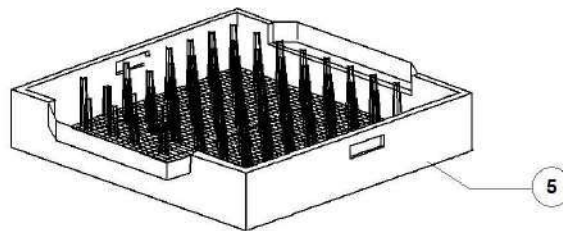
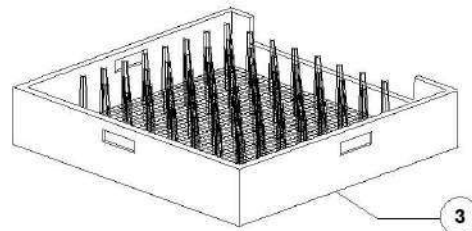
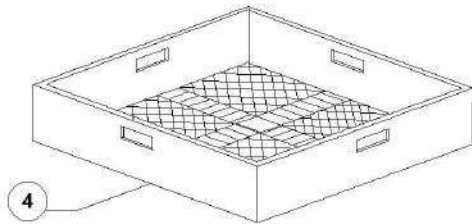
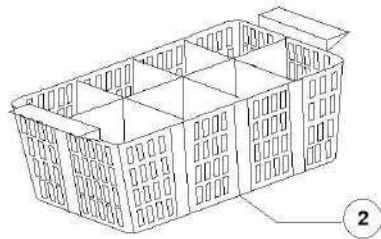
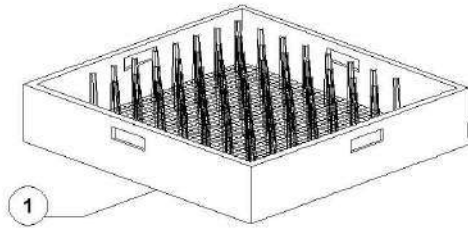

Pos.	Code	Descrizione	Description
1	DWC40	CESTO PIATTI PLASTICA 50X50	PLASTIC PLATES BASKET 500X500
2	DWC47	CESTELLO POSATE 8 POSTI	CUTLERY BASKET 8 PLACES
3	DWC43	CESTO TRAINO VASSOI (LATO APERTO)	TRAYS BASKET (ONE SIDE OPEN)
4	DWC44	CESTO BICCHIERI MAGL.LARGA PLASTICA	500X500 LARGE MESH GLASS BASKET

+7(812)987-08-81

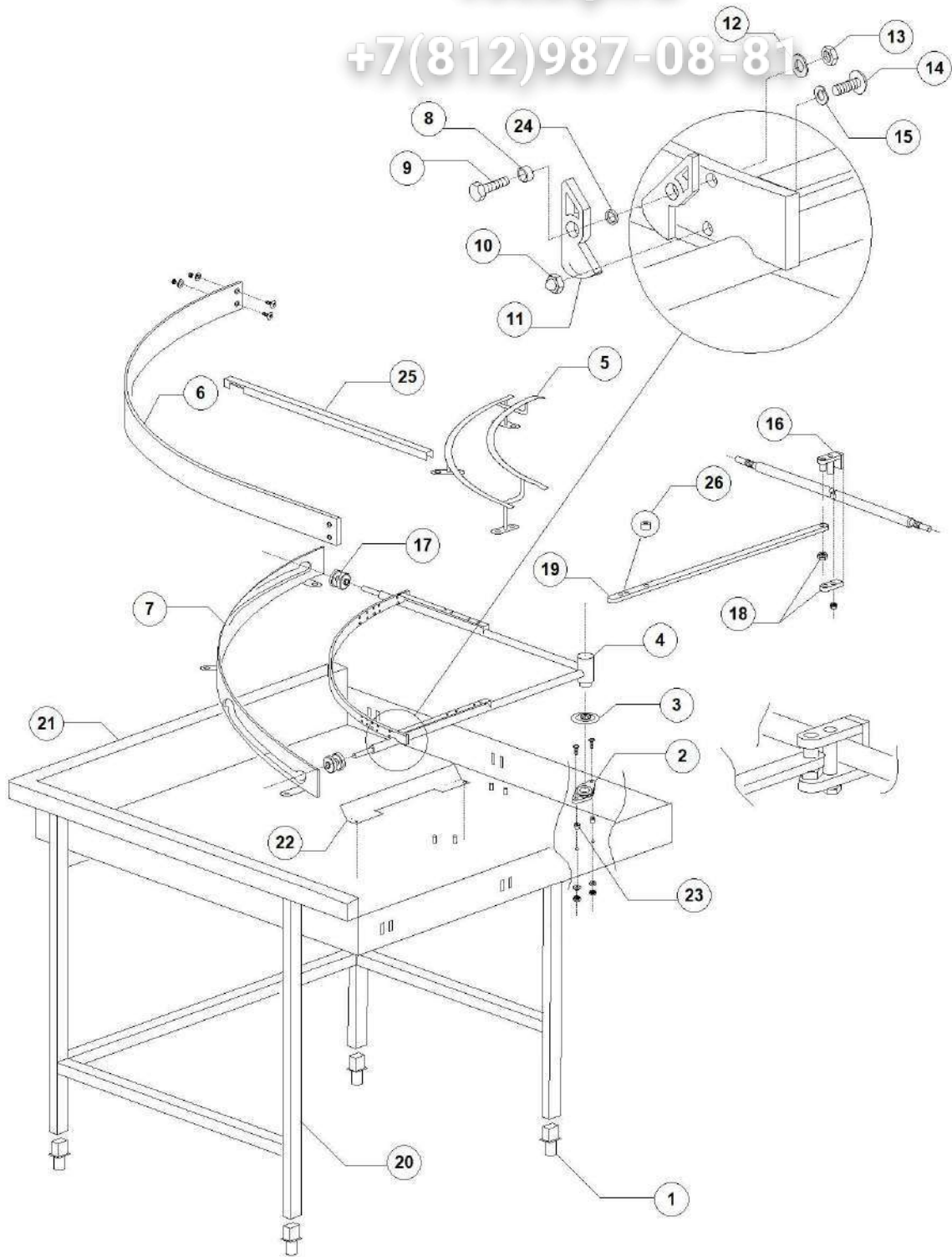



Pos.	Code	Descrizione	Description
1	DW3000252	PIEDINO INOX 1" PER TUBO 40X40X1"	S/S 1" FOOT
2	DW3000260	SUPP.FLANGIATO CATENA CURVA SFT20	FLANGE FOR CHAIN
3	DW3004161	DISCO ANTIGOCCIA PER ASSE MOTORIDUT	PROTECTION DISK
4	DW3063006	TRASPORTO CENTRALE C.MECC.90°	MECHANIZED ARC CENTRAL TRANSPORT 90°
5	DW3063002	TONDINO PORTACESTO INTERNO C.MECC. 90°	MECHANIZED ARC INNER SUPPORT BASKET 90°
6	DW3063003	GUIDACESTO EST. C.MECC. 90°	EXTERNAL MECH.ARC BASKET GUIDE 90°
7	DW3063005	PIATTO CALANDRATO C.MECC. 90°	MECHANIZED ARC 90° CENTRAL GUIDE ASSEMBLY
8	DW3003060	DISTANZ. PER ARPIONE SU TAV. E CURVE MEC	PAWL SPACER
9	DW11128	VITE INOX M10X25 TE DIN933	M10X25 TE S/S SCREW
10	DW11707	DADO M5 CIECO CALOTTA SEMISF. A2 DIN1587	S/S CAP NUT M5 DIN1587
11	DW3063009	ARPIONE INOX C. MECC.	MECHANIZED ARC S/S PAWL
12	DW11192	RONDELLA GROWER M10 INOX DIN 127B	M10 S/S GROWER WASHER DIN127B
13	DW11719	DADO M10 INOX DIN 934	S/S NUT M10 DIN934
14	DW11197	VITE M5X10 TCB INOX DIN 7985	M5X10 TCB S/S SCREW DIN7985
15	DW11608	RONDELLA GROWER M5 INOX UNI1751 DIN127	M5 S/S GROWER WASHER UNI1751 DIN127
16	DW3063008	AGGANCIO ASSE MACCHINA	MACHINE AXLE COUPLING
17	DW3063007	RUOTA C.MECC. 90°	WHEEL FOR MECHANIZED ARC 90°
18	DW3063010	CONTRODADO AGG. ASSE CARELLO CUR. MECC.	LOCK NUT
19	DW3063004	BIELLA CONN. MACCHINA C.MECC. 90°	CONNECTION ROD FOR MECHANIZED ARC 90°
20	DW3063001	TELAIO CURVA MECCANIZZATA 90°	MOBILE FRAME MECHANIZED 90° ARC
21	DW3063000	PIANALE CURVA MECCANIZZATA 90°	MECHANIZED ARC 90° SURFACE
22	DW391080	SPONDINA RICIRC. ARIA ASCIUG. TYPE 91-92	S/S FLAP FOR AIR CIRCULATION
23	DW10600206	OGIVA IN NYLON D.8	SEAL WASHER D.8 NYLON
24	DW3003024	RONDELLA CARRELLO 19X12X1 PTFE	WASHER 19X12X1 PTFE
25	DW3063016	PROFILO DI CHIUSURA E PROTEZIONE	CLOSING AND PROTECTION SECTION
26	DW3003158	DISTANZIALE BIELLA CURVA MECC.	MECHANIZED ARC SPACER

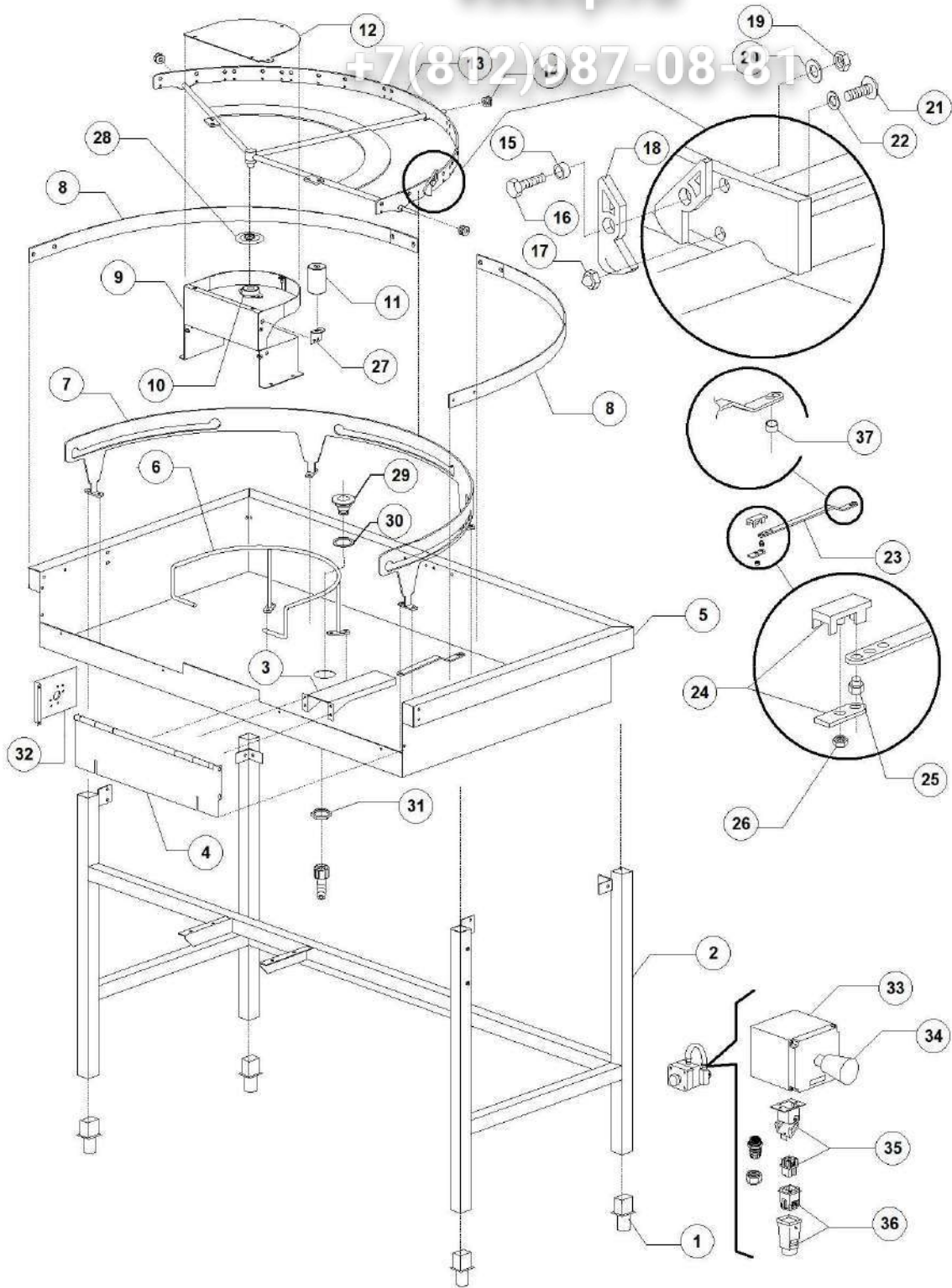

Pos.	Code	Descrizione	Description
1	DW3000252	PIEDINO INOX 1" PER TUBO 40X40X1"	S/S 1" FOOT
2	DW3003133	TELAIO CURVA MECCANIZZATA 180°	MOBILE FRAME MECHANIZED 180° ARC
3	DW3009717	CARTER DI PROTEZIONE	PROTECTION
4	DW3009718	SPONDINA. AGG. CURVA MEC. 180°	MECHANIZE ARC BOARD 180°
5	DW3009714	VASCA PER CURVA MECCANIZZATA 180°	TANK FOR 180° MECHANIZED ARC
6	DW3063011	ASS. TONDO GUIDACESTO C.MECC. 180°	MECH.ARC BASKET GUIDE STEEL ROD 180°
7	DW3063013	ASS. GUIDA TRASPORTO CENTRALE C.MEC.180°	MECH.ARC 180° CENTRAL GUIDE ASSEMBLY
8	DW3063014	GUIDACESTO EST. C.MECC. 180°	EXTERNAL MECH.ARC BASKET GUIDE 180°
9	DW3009713	OMEGA SUPPORTO CON GUIDACESTO	OMEGA SHAPED SUPPORT WITH BASKET GUIDE
10	DW3000260	SUPP.FLANGIATO CATENA CURVA SFT20	FLANGE FOR CHAIN
11	DW3000262	RULLO A SBALZO D.50X80 M8X25	50X80 EMBOSSEMENT ROLLER
12	DW3009715	COPERCHIO PER OMEGA SU CURVA MEC. 180°	MECHANIZED ARC 180° OMEGA COVER
13	DW3063012	ASSIEME TRASPORTO CENTRALE C.MECC.180°	MECHANIZED ARC 180° CENTRAL ASSEMBLY
14	DW3063007	RUOTA C.MECC. 90°	WHEEL FOR MECHANIZED ARC 90°
15	DW3003025	BOCCOLA DIST. CARRELLO 11,7X10X6 IN	SPACER FOR CARRIAGE 11,7X10X6
16	DW11109	VITE INOX M10X20 TE DIN933	M10X20 TE S/S SCREW DIN933
17	DW11707	DADO M5 CIECO CALOTTA SEMISF. A2 DIN1587	S/S CAP NUT M5 DIN1587
18	DW3063009	ARPIONE INOX C. MECC.	MECHANIZED ARC S/S PAWL
19	DW11179	RONDELLA 10X40 PIANA ZINCATA DIN9021	10X40 ZINC PLATED PLAIN WASHER
20	DW11192	RONDELLA GROWER M10 INOX DIN 127B	M10 S/S GROWER WASHER DIN127B
21	DW11197	VITE M5X10 TCB INOX DIN 7985	M5X10 TCB S/S SCREW DIN7985
22	DW11608	RONDELLA GROWER M5 INOX UNI1751 DIN127	M5 S/S GROWER WASHER UNI1751 DIN127
23	DW3063015	BIELLA CONN. MACCHINA C.MECC. 180°	CONNECTION ROD FOR MECHANIZED ARC 180°
24	DW3063008	AGGANCIO ASSE MACCHINA	MACHINE AXLE COUPLING
25	DW3063010	CONTRODADO AGG. ASSE CARELLO CUR. MECC.	LOCK NUT
26	DW11718	DADO M8 AUTOBLOCCANTE INOX DIN 982	S/S SELF-LOCKING NUT M8 DIN982
27	DW3009716	SQUADRETTA DI RINFORZO A L	REINFORCING ANGLE BRACKET
28	DW3004161	DISCO ANTIGOCCIA PER ASSE MOTORIDUT	PROTECTION DISK
29	DW10200113	PILETTA SCARICO	FLOOR DRAIN
30	DW10200173/A	GUARNIZIONE 75X58X3	75X58X3 GASKET
31	DW10200114	DADO PILETTA G2 ESA-75	FLOOR DRAIN NUT
32	DW3009393	SUPPORTO PULSANTE EMERGENZA	EMERGENCY BUTTON SUPPORT
33	DW3000264	SCATOLA IP55 PER EMERGENZA CURVA	ARC EMERGENCY BOX IP55
34	DW3000263	#PUL.EMER.CURVA N.V. 3002050+3002056+AG)	EMERGENCY SWITCH
34	DW3002050	PULS.FUNGO D.35 OP.SBLOC.ROT. 30A3	EMERGENCY BUTTON
35	DW3000266	CONNESSIONE PRESA MASCHIO 5 POLI	MALE CONNECTOR WITH SUPPORT
36	DW3000267	CONNESSIONE PRESA FEMMINA 5 POLI	FEMALE CONNECTOR WITH SUPPORT
37	DW3003158	DISTANZIALE BIELLA CURVA MECC.	MECHANIZED ARC SPACER

+7(812)987-08-81

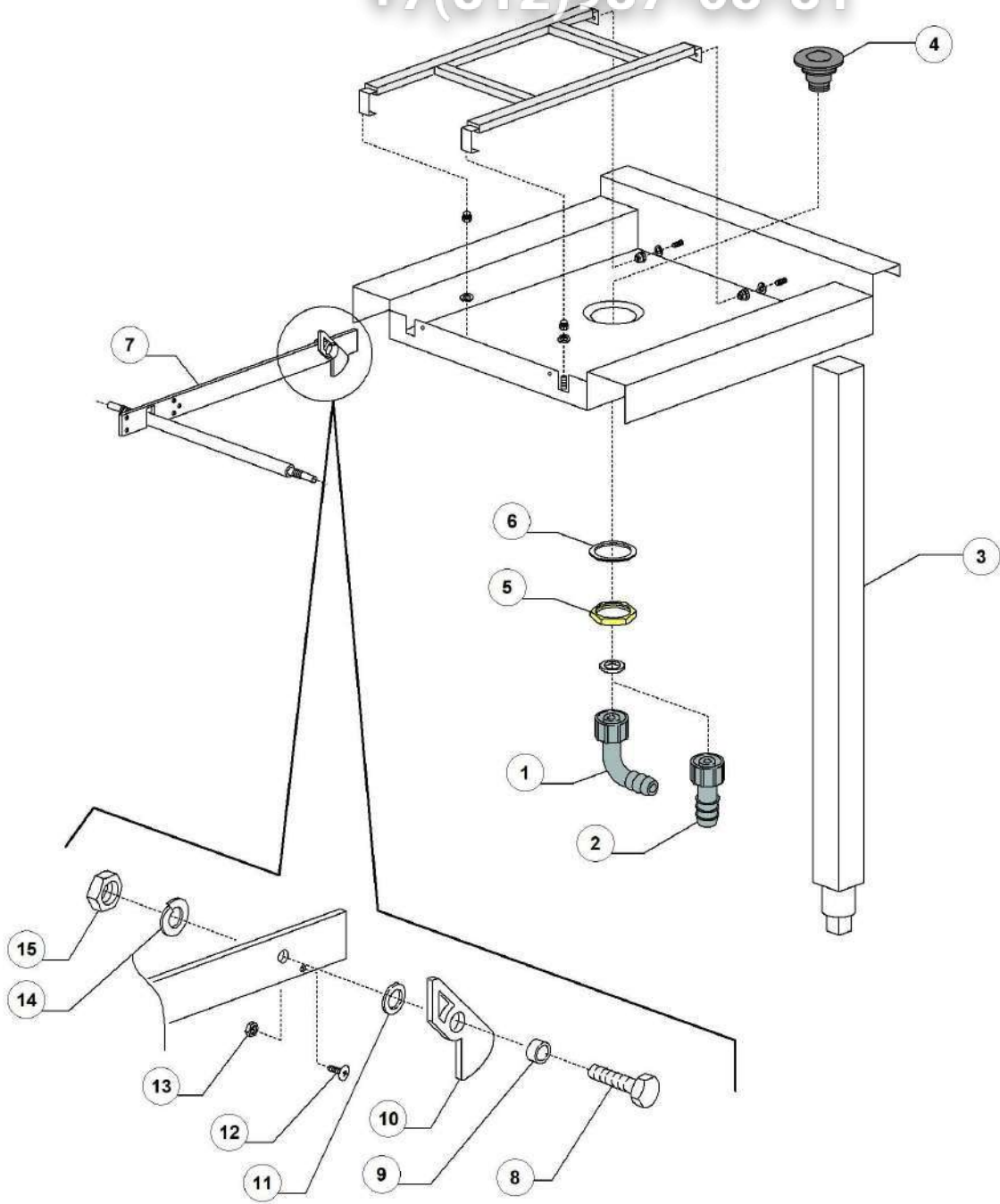

Pos.	Code	Descrizione	Description
1	DW15613	GOMITO NYLON SCARICO 1"1/4X32"	DRAIN ELBOW
2	DW15613/A	PORTAGOMM.SCARICO 1"1/4X32 DRITTO	STRAIGHT HOSE CONNECTOR
3	DW3009608	#ASS.GAMBA PER LC98	LEG ASSEMBLY
4	DW10200113	PILETTA SCARICO	FLOOR DRAIN
5	DW10200114	DADO PILETTA G2 ESA-75	FLOOR DRAIN NUT
6	DW10200173	GUARNIZIONE 75X58X2	75X58X2 GASKET
7	DW3003071	SUPPORTO ARPIONE TAV. ANG. 35X6X450	ANGLE TABLE PAWL SUPPORT
7	DW3003071/A	SUPP. MAGG. ARPIONE TAV. ANG. 35X6X600	ANGLE TABLE PAWL SUPPORT
8	DW11128	VITE INOX M10X25 TE DIN933	M10X25 TE S/S SCREW
9	DW3003060	DISTANZ. PER ARPIONE SU TAV. E CURVE MEC	PAWL SPACER
10	DW3063009	ARPIONE INOX C. MECC.	MECHANIZED ARC S/S PAWL
11	DW3003024	RONDELLA CARRELLO 19X12X1 PTFE	WASHER 19X12X1 PTFE
12	DW11197	VITE M5X10 TCB INOX DIN 7985	M5X10 TCB S/S SCREW DIN7985
13	DW11707	DADO M5 CIECO CALOTTA SEMISF. A2 DIN1587	S/S CAP NUT M5 DIN1587
14	DW11192	RONDELLA GROWER M10 INOX DIN 127B	M10 S/S GROWER WASHER DIN127B
15	DW11719	DADO M10 INOX DIN 934	S/S NUT M10 DIN934

Зип Общепит

[vsezip.ru](http://vsezip.ru)

+7(812)987-08-81

